

Voi e DS UNA COPPIA VINCENTE



CATALOGO RICAMBI ASCENSORI

EDIZIONE 2023



DS DICTATOR SRLU

Via P. e M. Curie 5/7 (accesso da Via Pasteur) - 20019 Settimo Milanese (MI)
Tel. 02 47994578 - 02 47995278 - Fax 02 47995131

e-mail per informazioni:

info@dsdictator.it

tecnico-commerciale@dsdictator.it

e-mail per ordini:

ordini@dsdictator.it

e-mail per contabilità:

contabilita@dsdictator.it

www.dsdictator.net

Controllo accessi

web sites:

www.dsdictator.com

www.dsdictator.it

**107 Chiudiporta per
ascensori
Ricambi per ascensori**

**Chiudiporta - Molle a gas
Ammortizzatori
Elettromagneti
Automazioni anche Atex**

METODO DI RICERCA ALFABETICO FACILITATO
ESEMPIO: RICERCA “PATTINO GUIDA SAFOV”

1. Cercare l’iniziale “P” (Pattino) sull’indice alfabetico
2. Sotto la lettera “P” cercare la voce “pattino (guarnizioni) monoblocco per guide”
3. A lato della voce “pattini per guide” si trova il numero del divisorio 19
4. Aprire il catalogo al divisorio N.19
5. Riportato sull’indice del divisorio N.19 “Pattini guida SAFOV”, accanto si troverà il numero di pagina (19.21)

ALPHABETIC SEARCH METHOD TO FIND ITEM INSIDE OF THE CATALOGUE
FOR EXAMPLE: FINDING “DOOR CLOSERS BASSETTI”

1. *Search the letter “D” (door closer) in the alphabetic index*
2. *Find the word “door closers”*
3. *Next, on right side of the word “door closer” look at the number of the chapter in this case “N.1”*
4. *Open the catalogue chapter “N.1”*
5. *Search index of the chapter “N.1” to find “door closer BASSETTI” in door closer are used in Italy whether manual or semiautomatic for swing door, then get the page number in right side page 1.9*



INDICE ALFABETICO PARTI STACCATE ASCENSORI VARI IGV, CEAM, SCHLIEREN, FORSID, FIAM, OTIS, SAFOV, FALCONI, BASSETTI, SABIEM, CIOCCA, SCHINDLER

A

Alimentatore	CAP. 30
Ammortizzatore per porte battente STAHL, AKRON, OTIS	CAP. 2
Ammortizzatori fossa	CAP. 2
Ammortizzatori per elettromagneti pattino retrattile	CAP. 2
Ammortizzatori per operatore e porte scorrevoli e soffietto FORSID benematic CEITA	CAP. 2
Angolare alto portine cabina	CAP. 8
Angolare basso portine cabine	CAP. 8
Arresto fisso in fossa DPR n.587 (puntone)	CAP. 16
Assieme camme e scivoli SCHINDLER e FIAM	CAP. 13
Attrezzo tira-aggancio molla	CAP. 8

B

Bandelle tira molla porte piano SCHINDLER	CAP. 8
Bielle abbinamento porte automatiche SCHINDLER	CAP. 13
Bielle operatori sospensioni	CAP. 6
Blocchetto chiave emergenza STANDARD, FIAM, KRONENBERG	CAP. 14
Bobine	CAP. 5
Bride	CAP. 16

C

Camma selettore SCHINDLER	CAP. 25
Camme azionamento commutatori e finecorsa	CAP. 7
Camme azionamento operatore A2PO - camma azionamento operatore OTIS	CAP. 6
Campane badenia	CAP. 30
Capifuni	CAP. 16
Carboni	CAP. 4
Cassette porta chiavi e porta documenti	CAP. 26
Cavo piatto certificato IMQ per ascensori	CAP. 21
Cerniere porte di piano e portine cabina	CAP. 8
Chiavi emergenza FIAM, SCHINDLER, STANDARD	CAP. 28
Chiudiporta diversi	CAP. 1



Chiudiporta montaggio sovrapposto al battente per modifica porte manuali in semiautomatiche e chiudiporta junior per chiusura portine di cabine	CAP.	1
Chiudiporta per porte a battente e operatori DICTATOR ORIGINAL usati in Italia	CAP.	1
Chiudiporta tipo "LEVA"	CAP.	1
Chiudiporta tubolari	CAP.	1
Cinghie bandelle di richiamo porta di piano SCHINDLER	CAP.	8
Cinghie operatori	CAP.	10
Commutatori di piano standard, stagni ed antideflagranti	CAP.	7
Commutatori finecorsa standard, stagni ed antideflagranti, e ricambi per comm. finecorsa (lamelle per contatti)	CAP.	7
Componenti diversi per operatori e sospensioni (ganci, leva di aggancio, scivoli, scatole di aggancio, ecc.)	CAP.	6
Contatti di pulsantiere piano e cabina	CAP.	9
Contatti finecorsa ad asta, rotella, sfera, leva	CAP.	3
Contatti per operatori sospensioni	CAP.	3
Contatti per porte a battente	CAP.	3
Contatti per portine cabina	CAP.	3
Contatti ricambio di teleruttori, relais, connessioni poli FM, in generale diodi resistenza teleruttori per quadri ascensori	CAP.	4
Cornici in alluminio per porte di piano	CAP.	8

D

Depuratore d'aria per cabina ascensore anti COVID e batteri Ds Air extra compact.....	CAP.	32
Dictator originali 78 modelli garantiti	CAP.	1
Dispositivi autolivellamento imp. oleodinamico (trolley)	CAP.	7
Dispositivi di chiusura (chiudiporta)	CAP.	1
Display	CAP.	9

E

Elettromagneti con/senza pattino retrattile incorporato standard e antideflagrante	CAP.	12
Elettromagneti freno argano	CAP.	12

F

Fermacavi piatti ed a cuneo tipo zeppa	CAP.	21
Fermo porta a slitta	CAP.	1
Ferodo	CAP.	15
Fotocellule standard, a raggi multipli, antideflagranti, mini ed extra compatte	CAP.	30



Frizioni FIAM, SCHINDLER CAP. 22

Funi metalliche di trazione CAP. 16

G

Ganci di blocco meccanico operatori porte CAP. 6

Giunti motore CAP. 27

Gomme (rotelle) per limitatore di velocità CAP. 29

Grasso CAP. 15

Grebiule (paramento) CAP. 16

Guarnizioni per guide CAP. 19

I

Impulsori, induttori magnetici a lama tagliaflusso, a calamita e antideflagranti CAP. 7

Indicatore di livello olio argano SCHINDLER CAP. 12

Ingranaggi operatori CAP. 11

Interruttore a chiave CAP. 3

Interruttori di emergenza per impianti oledinamici ed a fune per vano scala standard ed antidefagranti CAP. 9

L

Lama tagliaflusso per impulsori, induttori magnetici CAP. 7

Lampadine (baionetta, filetto, siluro, wedge, etc.) CAP. 23

Lardoni per guide (pattini) CAP. 19

Leve apri-freno + castello per freno argano FIAM CAP. 12

Leve operatori sospensioni CAP. 6

Limitatori di velocità CAP. 16

Lampada portatile 220 V tipo "officina" CAP. 23

M

Maniglie CAP. 8

Martelletti per selettore SCHINDLER CAP. 25

Microswitches CAP. 3

Molla con supporto porte di piano SCHINDLER CAP. 8

Molle per porte di piano a battente CAP. 8

Molle per portine cabina a battente CAP. 8

Molle per sospensioni porte scorrevoli CAP. 8

Molle varie CAP. 8



Morsetti fune	CAP. 16
Morsettiere 60 e 30 morsetti	CAP. 21
Motorizzazione l'automazione di porte a battente di piano (vedi handicappati) o automazione porte di piano a battane montato o montacarichi	CAP. 24

O

Olio	CAP. 15
Operatore per automazione porta di piano con montaggio sopra il tetto cabine per handicappati o per automazione porte a battente o montacarichi	CAP. 24

P

Paramenti	CAP. 16
Pattini contrappeso	CAP. 19
Pattini fune	CAP. 19
Pattini portine fisse a farfalla, antine, soglia	CAP. 19
Pattini retrattili, elastici con ritorno a molla	CAP. 13
Pattino (guarnizioni) monoblocco per guide	CAP. 19
Pattino retrattile con camma scivolo incorporato	CAP. 13
Pattini retrattili elettromagnetici	CAP. 12
Perni per porta di piano con aggancio molla	CAP. 8
Pignoni, pignoni con puleggia integrata per cinghia	CAP. 11
Plafoniere (OTIS, SCHINDLER, BASSETTI)	CAP. 23
Portapattini metallici e in ghisa	CAP. 18
Profili in gomma per battuta portine scorrevoli e cancelli a ghigliottina	CAP. 20
Pulegge di trazione e di rinvio	CAP. 18
Pulsanti e contatti pulsantiere di ricambio	CAP. 9
Pulsantiere di manutenzione standard - stagne ed antideflagrante	CAP. 9
Pulsantiere di piano e di cabina standard	CAP. 9
Pulsantiere di piano elettroniche intercambiabili BASSETTI, FIAM, SAFOV	CAP. 9
Pulsantiere stagne ed antideflagranti	CAP. 9
Puntone mobile DPR 587 del 9.12.87	CAP. 16

R

Redance per funi	CAP. 16
Regolatori di velocità	CAP. 16



Relais	CAP. 4
Resistenze	CAP. 4
Rondelle spessoramento pattino guide	CAP. 19
Rotelle per commutatori	CAP. 14
Rotelle per ganci di blocco operatore SCHINDLER, FIAM, OTIS	CAP. 6
Rotelle per leve serrature	CAP. 14
Rulli per arcate oleodinamiche	CAP. 10
Rulli per operatori e sospensioni	CAP. 10
Ruote in gomma per limitatori FALCONI, FIAM, SCHINDLER, OTIS	CAP. 29
Ruote per funi operatori e sospensioni	CAP. 10
Ruote per operatori e sospensioni con pista a bordo inclinato a parallelo, tondo in termoplastico	CAP. 10

S

Sagome commutazione finecorsa	CAP. 7
Scivoli-siluri per porte scorrevoli	CAP. 31
Selettore elettrico SIL	CAP. 25
Selettore OTIS vari modelli e ricambi	CAP. 25
Selettore SCHLIEREN vari modelli e ricambi	CAP. 25
Selettori vari e ricambi per selettori	CAP. 25
Serratura a spinta, pomolo e ricambi, serratura standard, stagne a antideflagranti per porte a battente, blocchetto chiave emergenza triangolare e dispositivo chiave emergenza FIAM	CAP. 14
Serratura per operatori porte scorrevoli automatiche e loro componenti	CAP. 6
Sirene di allarme ascensore	CAP. 30
Spazzole	CAP. 5
Spessori per argani e guide cabina	CAP. 17
Supporti (staffe) per oliatori	CAP. 15
Supporti antivibranti in gomma	CAP. 27
Supporti operatori	CAP. 10
Supporti pattini, guarnizioni guide	CAP. 18

T

Tamponi in gomma per porte automatiche, porte a battente, aste bielle operatori sospensioni, pattini retrattili, cabine, antivibranti	CAP. 27
Tamponi porte a battente	CAP. 8
Targhe varie	CAP. 26



Teleruttori	CAP.	4
Telesoccorso per cabina	CAP.	32
Temporizzatori	CAP.	4
Tenditori a peso per limitatore	CAP.	16
Tiranti per fune	CAP.	16
Trasformatori	CAP.	5

V

Vaschette raccogli olio guide	CAP.	15
-------------------------------------	------	----

Z

Zenematic	CAP.	4
-----------------	------	---



ALPHABETIC INDEX FOR LIFT SPARE PARTS DIFFERENT BRANDS SUCH AS IGV, CEAM, SCHLIEREN, FORSID, FIAM, OTIS, SAFOV, FALCONI, BASSETTI, SABIEM, CIOCCA, SCHINDLER

A

Air cleaner anti COVID and bacteria for cabin lift Ds Air extra compact..... CAP. 32

Alarms bell CAP. 30

Angular for high cabin door CAP. 8

Angular for low cabin door CAP. 8

Anti - vibration support in rubber CAP. 27

Automatic self - levelling device CAP. 7

B

Belt for landing door SCHINDLER CAP. 8

Belt for operator CAP. 10

Break release traction levers FIAM CAP. 12

Brush CAP. 5

C

Cam A2PO - operator cam OTIS CAP. 6

Cam for selector SCHINDLER CAP. 25

Ceiling light (OTIS, SCHINDLER, BASSETTI) CAP. 23

Central system for optic and signal sound CAP. 30

Clutches FIAM, SCHINDLER CAP. 22

Coal CAP. 4

Coils CAP. 5

Contactors CAP. 4

Contacts for cabin door CAP. 3

Contacts for operator and hanger CAP. 3

Contacts for swing door CAP. 3

Contacts spare parts, relay, contactor, resistors CAP. 4

Counter weight guide shoe CAP. 19

Counter weight rope CAP. 19

D

Damper for electromagnet of retiring cam CAP. 2

Damper for hinged door STAHL, AKRON, OTIS CAP. 2



<i>Damper for operator and sliding door and folding door FORSID benematic CEITA</i>	CAP.	2
<i>Device for closing door</i>	CAP.	1
<i>DICTATOR original in 78 models granted</i>	CAP.	1
<i>Different components for operators and hanger (hook, vane cam, hook box)</i>	CAP.	6
<i>Display</i>	CAP.	9
<i>Door closer “leve” type</i>	CAP.	1
<i>Door closer for swing doors and DICTATOR operator used in Italy</i>	CAP.	1
<i>Door closer mounting overlapping for swing door in modification door manually in semi automatic and junior door closer for cabin door closing</i>	CAP.	1
<i>Door coupling device for automatic door SCHINDLER and FIAM</i>	CAP.	13
<i>Door coupling slide for sliding door</i>	CAP.	31
<i>Door lock for operator automatic sliding door and theirs components</i>	CAP.	6
<i>Door lock with keys, knob and spare parts, door lock standard, explosion proof for swing door, triangular emergency key lock and emergency key device FIAM</i>	CAP.	14
<i>Door stop overhead</i>	CAP.	1
<i>Driver unit for automatic door for handicap</i>	CAP.	24
<i>Driver unit for swing door and landing door (handicap)</i>	CAP.	24

E

<i>Electromagnet for break release traction</i>	CAP.	12
<i>Electromagnet with or without retiring guide shoe incorporated standard and explosion proof</i>	CAP.	12
<i>Electromagnetic retiring cam</i>	CAP.	12
<i>Electronic alarm lift</i>	CAP.	30
<i>Electronic timer type</i>	CAP.	4
<i>Emergency keys FIAM, SCHINDLER, STANDARD</i>	CAP.	28
<i>Emergency key block STANDARD, FIAM, KRONENBERG</i>	CAP.	14
<i>Emergency power supply</i>	CAP.	30
<i>Emergency switch and push buttons for explosion proof</i>	CAP.	9
<i>Emergency telephone for cabin</i>	CAP.	32

F

<i>Flat cable certificated IMQ for lift</i>	CAP.	21
<i>Flat rope anchorage</i>	CAP.	16
<i>Flexible motor</i>	CAP.	27
<i>Floor reverse speed limit standard, explosion proof, and spare parts for floor reverse speed limit (blade for contacts)</i>	CAP.	7



<i>Floor reverse standard and explosion proof</i>	CAP.	7
<i>Floor reverse switching cam and limit switch</i>	CAP.	7
<i>Frames for landing door</i>	CAP.	8

G

<i>Gear for operators</i>	CAP.	11
<i>Gib butterfly, cabin door gib, sil guide</i>	CAP.	19
<i>Gib for guide shoe</i>	CAP.	19
<i>Grease</i>	CAP.	15
<i>Guide shoe</i>	CAP.	19
<i>Guide shoe in metallic and cast iron</i>	CAP.	18
<i>Guide shoe support, gib support</i>	CAP.	18

H

<i>Hammer switch for selector SCHINDLER</i>	CAP.	25
<i>Handles</i>	CAP.	8
<i>Hinges for landing door and cabin door</i>	CAP.	8
<i>Hydraulic pit</i>	CAP.	2

K

<i>Key holder box and document holder</i>	CAP.	26
<i>Key switch</i>	CAP.	3

L

<i>Lamps (Baionetta, Filetto, Siluro, Wedge, ect)</i>	CAP.	23
<i>Lever operator and hanger</i>	CAP.	6
<i>Limit switch contacts with rod, sphere roller, lever</i>	CAP.	3
<i>Locking clamp for operator door</i>	CAP.	6
<i>Lubricator</i>	CAP.	15

M

<i>Magnetic switch, straight adjustable induction plate</i>	CAP.	7
<i>Metallic rope in traction</i>	CAP.	16
<i>Micro switch</i>	CAP.	3

O

<i>Oil collector for guide</i>	CAP.	15
<i>Oilers</i>	CAP.	15



<i>One - piece sliding shoe</i>	CAP. 19
<i>Operator support</i>	CAP. 10
<i>Over speed governor</i>	CAP. 16

P

<i>Photocells standard, multiple beams, explosion proof, small and extra compact</i>	CAP. 30
<i>Pinions, pinion with pulley</i>	CAP. 11
<i>Pivot for landing door with hook spring</i>	CAP. 18
<i>Portable lamp 220 V type "workshop"</i>	CAP. 23
<i>Portable strut (DPR n.587)</i>	CAP. 16
<i>Push buttons and contact push buttons with spare parts</i>	CAP. 9
<i>Push buttons counts for floor and cabin</i>	CAP. 9
<i>Push buttons maintenance standard and explosion proof</i>	CAP. 9
<i>Push buttons of BASSETTI, FIAM, SAFOV</i>	CAP. 9
<i>Push buttons of control panel anti explosion</i>	CAP. 9
<i>Push buttons of standard for cabin floor</i>	CAP. 9

R

<i>Rail clip</i>	CAP. 16
<i>Relay</i>	CAP. 4
<i>Resistors</i>	CAP. 6
<i>Retiring cam with vane and cam coupling</i>	CAP. 13
<i>Retiring cam, elastic with return of spring</i>	CAP. 13
<i>Return spring strap</i>	CAP. 8
<i>Reversing cam sheet metal for speed governor</i>	CAP. 7
<i>Rod for coupling automatic door SCHINDLER</i>	CAP. 13
<i>Rod for operator and hanger</i>	CAP. 6
<i>Roller for door lock lever</i>	CAP. 14
<i>Roller for floor reverse</i>	CAP. 14
<i>Roller for hook locking clamp operator SCHINDLER, FIAM, OTIS</i>	CAP. 6
<i>Roller for operator and hanger</i>	CAP. 10
<i>Roller for operator and hanger with parallel flange and inclined</i>	CAP. 10
<i>Roller for rope operator and hanger</i>	CAP. 10
<i>Roller hydraulic hoistway</i>	CAP. 10



<i>Roller in rubber for speed governor FALCONI, FIAM, SCHINDLER, OTIS</i>	CAP. 29
<i>Rubber pads for automatic door, swing door, operator and hanger, retiring cam, anti-vibrant</i>	CAP. 27
<i>Rubber pads for swing door</i>	CAP. 8
<i>Rubber roller for over speed governor</i>	CAP. 29
<i>Rubber washer for guide shoe</i>	CAP. 19

S

<i>Selector SIL electronic</i>	CAP. 25
<i>Selector OTIS and variety of model and spare parts</i>	CAP. 25
<i>Selector spare parts and variety of selector</i>	CAP. 25
<i>Selector SCHLIEREN and variety of models and spare parts</i>	CAP. 25
<i>Shim for traction machine and guide rail</i>	CAP. 17
<i>Speed governor</i>	CAP. 16
<i>Spring for cabin door</i>	CAP. 8
<i>Spring for hanger in sliding door</i>	CAP. 8
<i>Spring for landing door</i>	CAP. 8
<i>Spring for support landing door SCHINDLER</i>	CAP. 8
<i>Spring tightener</i>	CAP. 8
<i>Stop rubber profiles for sliding doors and guillotine gates</i>	CAP. 20
<i>Straight adjustable induction plate for cylindrical magnetic</i>	CAP. 7
<i>Support for oiler</i>	CAP. 15

T

<i>Tension rod for rope</i>	CAP. 16
<i>Tension weight for overspeed governor</i>	CAP. 16
<i>Toe - guard</i>	CAP. 16
<i>Toe - guard (sheet metal)</i>	CAP. 16
<i>Terminal block, trolley chock type wedge - lock</i>	CAP. 21
<i>Terminal board from 60 to 30</i>	CAP. 21
<i>Traction and tail sheave</i>	CAP. 18
<i>Traction oil level indicator SCHINDLER</i>	CAP. 12



Transformers CAP. 5

Tube door closer CAP. 1

V

Variety of plates CAP. 26

Variety of springs CAP. 8

Various door closer CAP. 1

W

Wire rope CAP. 16

Z

Zenematic CAP. 4

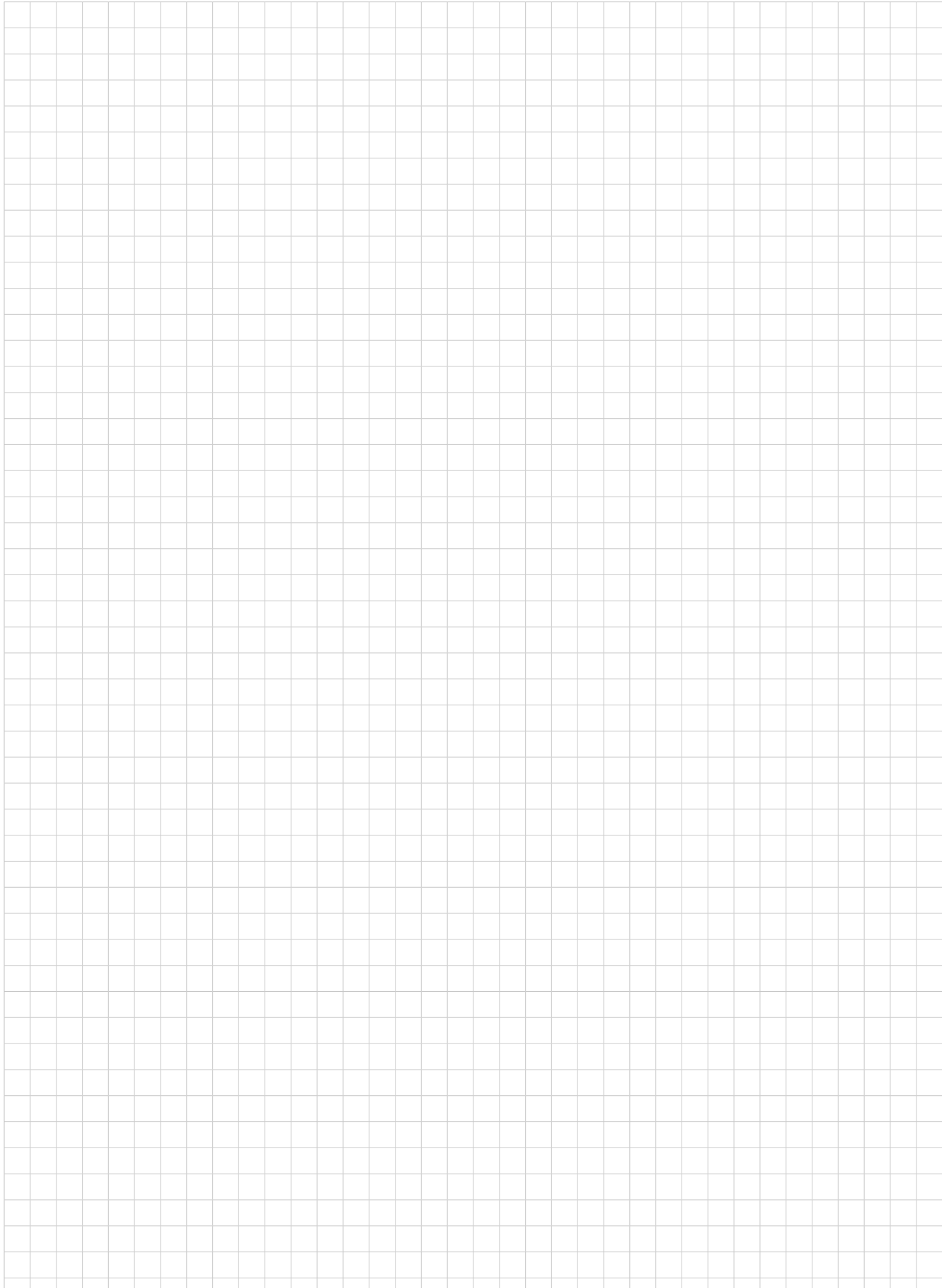

NOTE

CHIUDIPIORTA PER PORTE A BATTENTE E OPERATORI DICTATOR ORIGINAL USATI IN ITALIA

DOOR CLOSERS FOR SWING DOORS AND DICTATOR OPERATORS USED IN ITALY

Chiudiporta DICTATOR EUROPA standard Germania e inox	1.4
<i>Door closer DICTATOR EUROPA standard and Germany stainless steel</i>	
Chiudiporta DICTATOR EUROPA sfioramento basso	1.5
<i>Door closer DICTATOR EUROPA low touch</i>	
Chiudiporta DICTATOR EUROPA con asole	1.6
<i>Door closer DICTATOR EUROPA with eyelet</i>	
Chiudiporta DICTATOR EUROPA ORONA	1.7
<i>Door closer DICTATOR EUROPA ORONA</i>	
Chiudiporta DICTATOR SCHINDLER	1.8
<i>Door closer DICTATOR SCHINDLER</i>	
Chiudiporta DICTATOR BASSETTI	1.9
<i>Door closer DICTATOR BASSETTI</i>	
Chiudiporta DICTATOR VIFIAM rotella Ø 24 mm	1.10
<i>Door closer DICTATOR VIFIAM roller Ø 24 mm</i>	
Chiudiporta DICTATOR VIFIAM rotella Ø 30 mm	1.11
<i>Door closer DICTATOR VIFIAM roller Ø 30 mm</i>	
Chiudiporta DICTATOR VIFIAM AV101 alette ribassate	1.12
<i>Door closer DICTATOR VIFIAM AV101 with lower winds</i>	
Chiudiporta DICTATOR SAFOV "Alto" e SAFOV "Basso"	1.13 - 1.14
<i>Door closer DICTATOR SAFOV "High" and SAFOV "Low"</i>	
Chiudiporta DICTATOR per operatore SAFOV	1.15
<i>Door closer DICTATOR for SAFOV operator</i>	
Chiudiporta DICTATOR SAFOV a doppia rotella per operatore	1.16
<i>Door closer DICTATOR SAFOV double roller for operator</i>	
Chiudiporta DICTATOR SAFOV per portine di cabina (sotto alla cabina)	1.17
<i>DICTATOR lift door damper SAFOV for cabin doors (under the cabin)</i>	
Chiudiporta DICTATOR CIOCCA	1.18
<i>Door closer DICTATOR CIOCCA</i>	
Chiudiporta DICTATOR VIMEC rotella in basso	1.19
<i>Door closer DICTATOR VIMEC roller down</i>	
Chiudiporta DICTATOR standard ESP (Fermator)	1.20
<i>Door closer DICTATOR standard ESP (Fermator)</i>	

CHIUDIPIORTA TIPO A "LEVA"

DOOR CLOSERS "LEVER" TYPE

Chiudiporta DICTATOR LS FZ (Blu-Rosso)	1.21
<i>Door closer DICTATOR LS FZ (Blue-Red)</i>	
Chiudiporta DS Ryobi CO52 per sostituzione chiudiporta Dictator LSFZ blu (forza 15-20 N) per porte con cerniere usurate	1.22
<i>Door closer Ds Ryobi CO52 for replacement Dictator door closer LSFZ blue (force 15-20 N) for door with worn hinges</i>	

Chiudiporta Ds Ryobi CO52 per sostituzione FIAM fuori produzione	1.23
<i>Door closer Ds Ryobi CO52 for replacement FIAM out of production</i>	
Chiudiporta DICTATOR LS FZI + Kit sostituzione vecchi chiudiporta FIAM fuori produzione	1.24
<i>Door closer DICTATOR LS FZI + kit to replace old FIAM door closers out of production</i>	
Chiudiporta LX OTIS	1.25
<i>Door closer LX OTIS</i>	
Chiudiporta OTIS nuova esecuzione per sostituzione chiudiporta OTIS a leva vecchia esecuzione	1.26
<i>Door closer OTIS new execution for replacement OTIS door closer with lever old execution</i>	
Chiudiporta DS RYOBI CO52 - 53 - 54	1.27 - 1.28
<i>Door closer DS RYOBI CO52 - 53 - 54</i>	

CHIUDIPIORTA DIVERSI **VARIOUS DOOR CLOSERS**

Chiudiporta THIESS leva lunga e corta	1.29
<i>Door closer THIESS long and short lever</i>	
Sostituzione chiudiporta SABIEM con accessori Dictator porta a battente	1.30
<i>SABIEM door closer replacement with Dictator accessories swing door</i>	
Montaggio ammortizzatore Dictator con inserimento nel chiudiporta originale SCHLIEREN	1.31
<i>Mounting Dictator damper with insertion in the door closer original SCHLIEREN</i>	

CHIUDIPIORTA TUBOLARI **TUBE DOOR CLOSERS**

Chiudiporta "AUGUSTO STIGLER" DICTATOR	1.32
<i>"AUGUSTO STIGLER" DICTATOR door closer</i>	
Chiudiporta (solo ammortizzatore) FALCONI DICTATOR	1.33
<i>FALCONI DICTATOR door closer (only damper)</i>	
Chiudiporta tubolari DICTATOR serie ATS	1.34 - 1.35 - 1.36 - 1.37 - 1.38
<i>DICTATOR tube door closers ATS series</i>	

CHIUDIPIORTA MONTAGGIO SOVRAPPOSTO AL BATTENTE PER MODIFICA PORTE MANUALI IN SEMIAUTOMATICHE E CHIUDIPIORTA JUNIOR PER CHIUSURA PORTINE DI CABINA **DOOR CLOSER MOUNTING OVERLAPPING FOR SWING DOOR IN MODIFICATION DOOR MANUAL IN SEMIAUTOMATIC , AND JUNIOR DOOR CLOSER FOR CABIN DOOR CLOSING**

Chiudiporta DS RYOBI COU SE extra piatto spessore 30 mm	1.39 - 1.40
<i>DS RYOBI COU SE door closer extra flat thickness 30 mm</i>	
Chiudiporta DICTATOR LS FZ (vecchio FIAM con cassonetto in lamiera)	1.41
<i>DICTATOR LS FZ door closer (old FIAM with metal plate case)</i>	
Chiudiporta DICTATOR UNIVERSAL VS 2000	1.42
<i>DICTATOR UNIVERSAL VS 2000 door closer</i>	
Chiudiporta DICTATOR UNIVERSAL V 1600	1.43
<i>DICTATOR UNIVERSAL V 1600 door closer</i>	
Chiudiporta DICTATOR UNIVERSAL R 1400 - montaggio lato vano corsa	1.44
<i>DICTATOR UNIVERSAL R 1400 door closer - mounting on the shaft side</i>	
Chiudiporta DICTATOR UNIVERSAL H	1.45
<i>DICTATOR UNIVERSAL H door closer</i>	

Chiudiporta DICTATOR UNIVERSAL Z	1.46
<i>DICTATOR UNIVERSAL Z door closer</i>	
Chiudiporta DICTATOR JUNIOR per portine a battente di cabina	1.47
<i>DICTATOR JUNIOR door closer for cabin with swing doors</i>	
Regolatore di velocità DICTA TROLLEY da installare su porte SABIEM scorrevoli chiuse da molla al posto del vecchio regolatore di velocità SABIEM	1.48
<i>DICTA TROLLEY speed regulator can be installed on SABIEM sliding door, closed by spring instead of the SABIEM old speed regulator</i>	

FERMO PORTA A SLITTA

DOOR STOP IN SLIDE

Fermo porta sovrapposto per porte a battente	1.49
<i>Overlapping door stop for swing door</i>	

Note: I componenti sul catalogo con riportata una specifica marca di ascensore sono utilizzati abitualmente solo da questa marca. I particolari senza marca sono utilizzati da più marche di ascensori.

Note: *The components in the catalogue with a specific lift brand are usually used only by the brand. Unbranded parts are used by multiple lift brands.*

CHIUDIPIORTA DICTATOR STANDARD EUROPA - GERMANY DICTATOR LIFT DOOR DAMPER STANDARD EUROPE - GERMANY



Chiudiporta Dictator standard "EUROPA - GERMANY"

1. Decelerazione progressiva
2. Regolazione semplice: girando in senso orario aumenta la decelerazione, girando in senso antiorario diminuisce la decelerazione
3. Bronzine in metallo autolubrificante
4. Olio atermico
5. Cilindro ricavato da unico pezzo
6. Rotella in gomma antiusura con bronzina
7. Impianto robotizzato per collaudo del 100% dei chiudiporta prodotti

Dictator lift door damper standard "EUROPE - GERMANY"

1. Deceleration progressive
2. Simple adjustment: turning clockwise increase the damping, turning counter clockwise decrease the progressive damping
3. Bearings in autolubricant
4. Atermic oil
5. Cylinder made from a unique piece
6. Wear-resistant rubber roller with bearing
7. Robotic system for testing 100% of door closers products

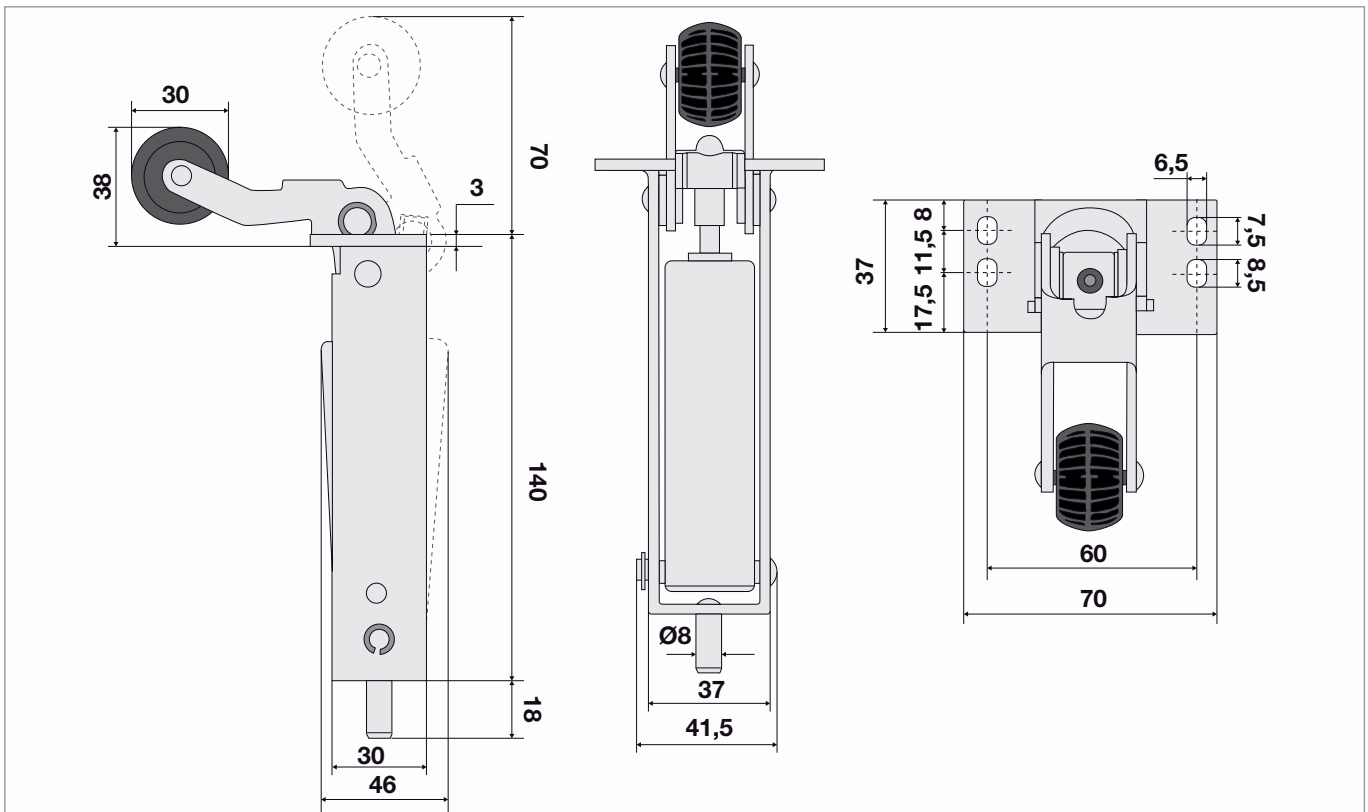

Codice / code	101000	100034	100032	101008	101000H	100033	101006	101014
Forza / Force	20 N	50N	50 N	80 N	20 N	80 N	120 N	80 N
Larghezza porta / door width	600 - 650	650 - 750	650 - 750	800 - 950	650 - 750	800 - 950	1000 - 1300	650 - 750
Montaggio Dictator / Installation Dictator	Metà porta	Metà porta	Metà porta	Metà porta	Spigolo opposto alla cerniera anche orizzontale	Metà porta	Metà porta	Metà porta
Peso Porta / Door weight	50 kg max	60 kg max	65 kg max	70 kg max Cilindro zincato	50 kg max	70 kg max	90 - 130 kg	60 kg 100% INOX
Materiale / Material	Acciaio	Acciaio	Acciaio	INOX AISI 304	Acciaio	Acciaio	Acciaio	INOX AISI 304

CHIUDIORTA DICTATOR STANDARD SFIORAMENTO BASSO DICTATOR LIFT DOOR DAMPER STANDARD LOW TOUCH



Chiudiporta Dictator standard "SFIORAMENTO BASSO"

1. Decelerazione progressiva
2. Regolazione semplice: girando in senso orario aumenta la decelerazione, girando in senso antiorario diminuisce la decelerazione
3. Bronzine in metallo autolubrificante
4. Olio atermico
5. Cilindro ricavato da unico pezzo
6. Rotella in gomma antiusura con bronzina
7. Impianto robotizzato per collaudo del 100% dei chiudiporta prodotti

Dictator lift door damper standard "LOW TOUCH"

1. Deceleration progressive
2. Simple adjustment: turning clockwise increase the damping, turning counter clockwise decrease the progressive damping
3. Bearings in autolubricant
4. Atermic oil
5. Cylinder made from a unique piece
6. Wear-resistant rubber roller with bearing
7. Robotic system for testing 100% of door closers products

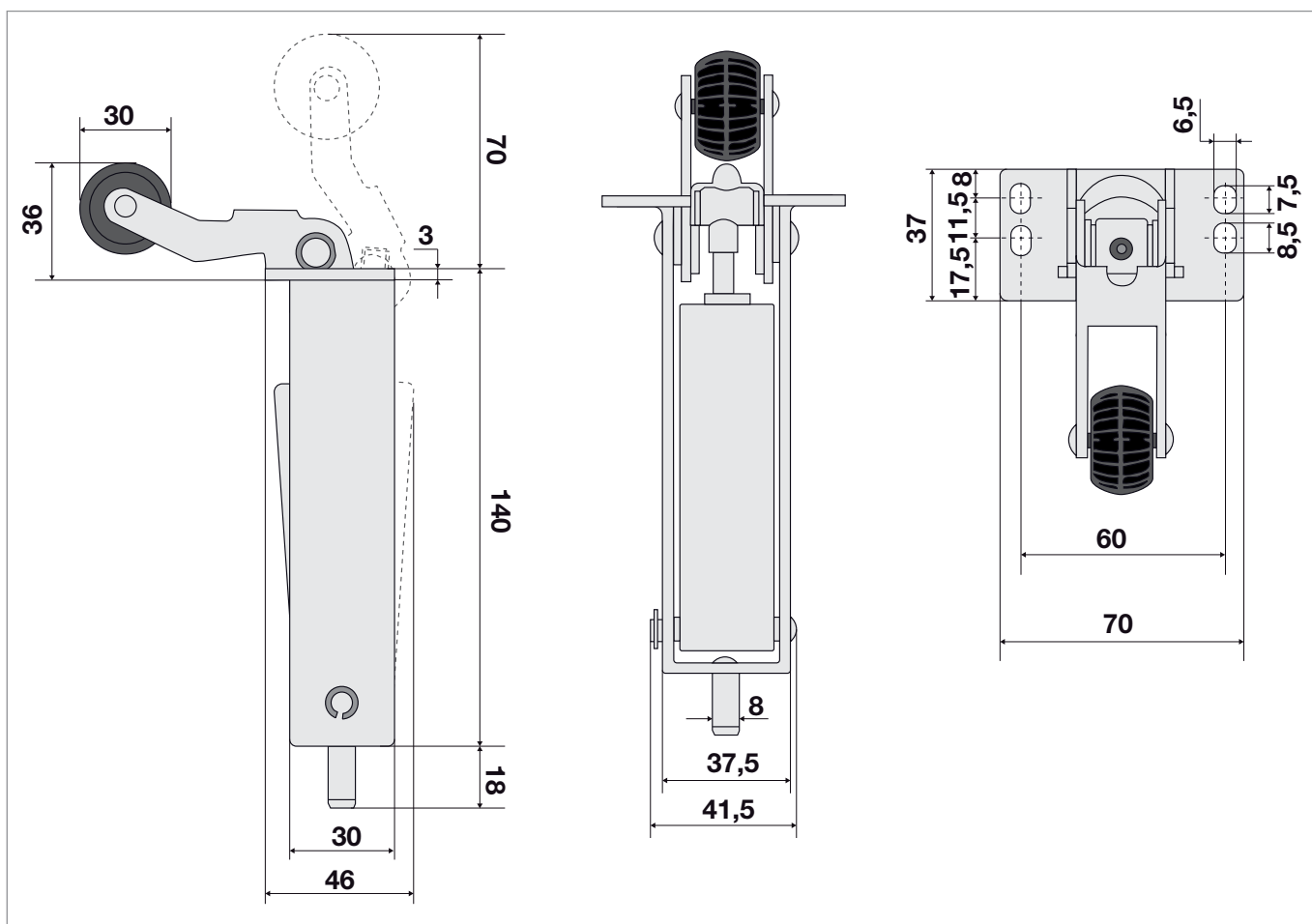

Codice / Code	Forza / Force	Descrizione / Description
101009	50 N	Chiudiporta Dictator standard sfioramento basso

CHIUDIPIORTA DICTATOR STANDARD CON ASOLE DICTATOR LIFT DOOR DAMPER STANDARD WITH BUTTON HOLE



Chiudiporta Dictator originale tipo "STANDARD CON ASOLE"

1. Decelerazione progressiva
2. Regolazione semplice: girando in senso orario aumenta la decelerazione, girando in senso antiorario diminuisce la decelerazione
3. Bronzine in metallo autolubrificante
4. Olio atermico
5. Cilindro ricavato da unico pezzo
6. Rotella in gomma antiusura con bronzina
7. Impianto robotizzato per collaudo del 100% dei chiudiporta prodotti

Dictator original lift door damper type "STANDARD WITH BUTTON HOLE"

1. Deceleration progressive
2. Simple adjustment: turning clockwise increase the damping, turning counter clockwise decrease the progressive damping
3. Bearings in autolubricant
4. Atermic oil
5. Cylinder made from a unique piece
6. Wear-resistant rubber roller with bearing
7. Robotic system for testing 100% of door closers products

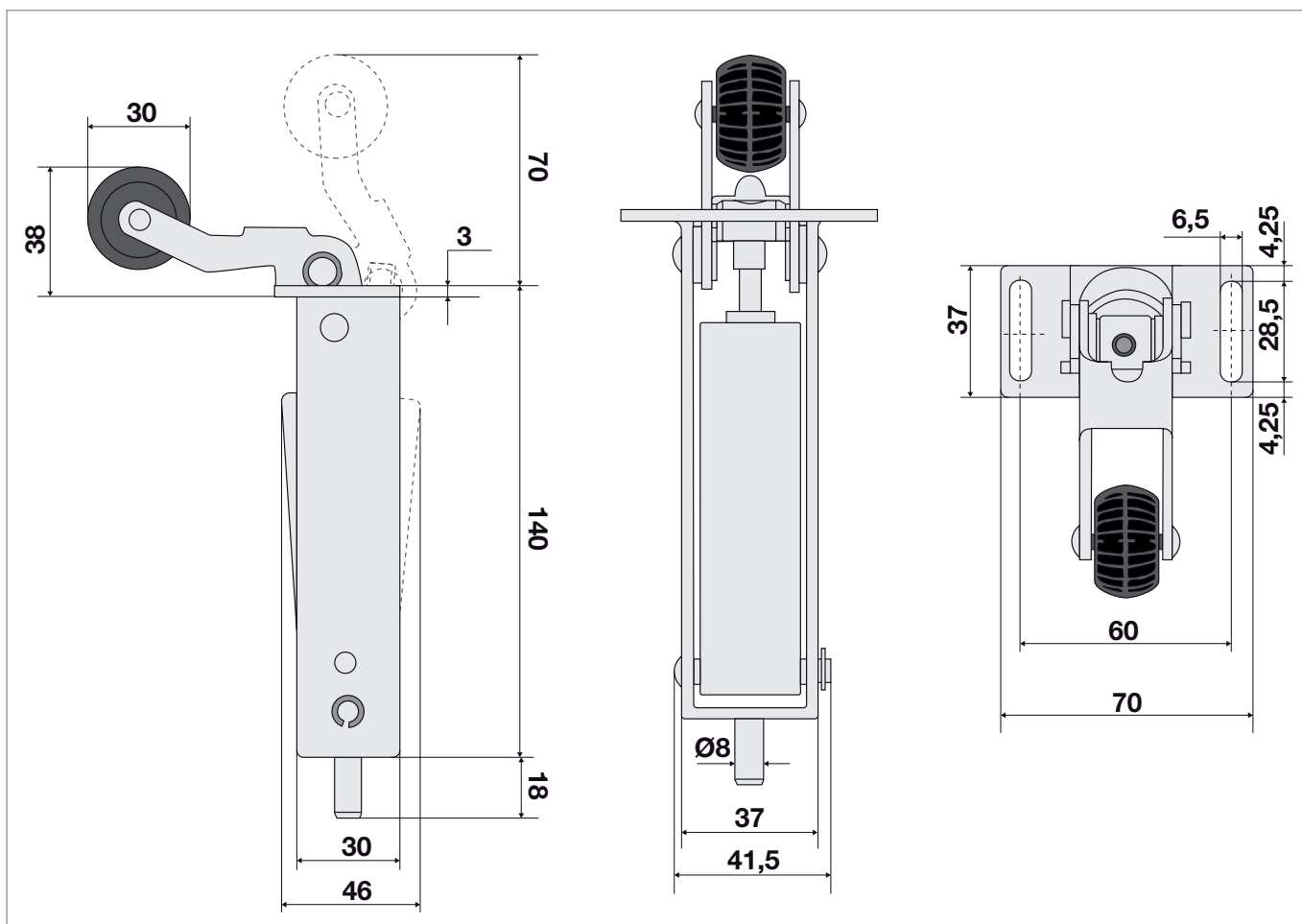

Codice / Code	Forza / Force	Descrizione / Description
100009	50 N	Chiudiporta Dictator standard con asole

CHIUDIPIORTA DICTATOR STANDARD ORONA DICTATOR LIFT DOOR DAMPER STANDARD ORONA



Chiudiporta Dictator standard "ORONA"

1. Decelerazione progressiva
2. Regolazione semplice: girando in senso orario aumenta la decelerazione, girando in senso antiorario diminuisce la decelerazione
3. Bronzine in metallo autolubrificante
4. Olio atermico
5. Cilindro ricavato da unico pezzo
6. Rotella in gomma antiusura con bronzina
7. Impianto robotizzato per collaudo del 100% dei chiudiporta prodotti

Dictator lift door damper standard "ORONA"

1. Deceleration progressive
2. Simple adjustment: turning clockwise increase the damping, turning counter clockwise decrease the progressive damping
3. Bearings in autolubricant
4. Atermic oil
5. Cylinder made from a unique piece
6. Wear-resistant rubber roller with bearing
7. Robotic system for testing 100% of door closers products

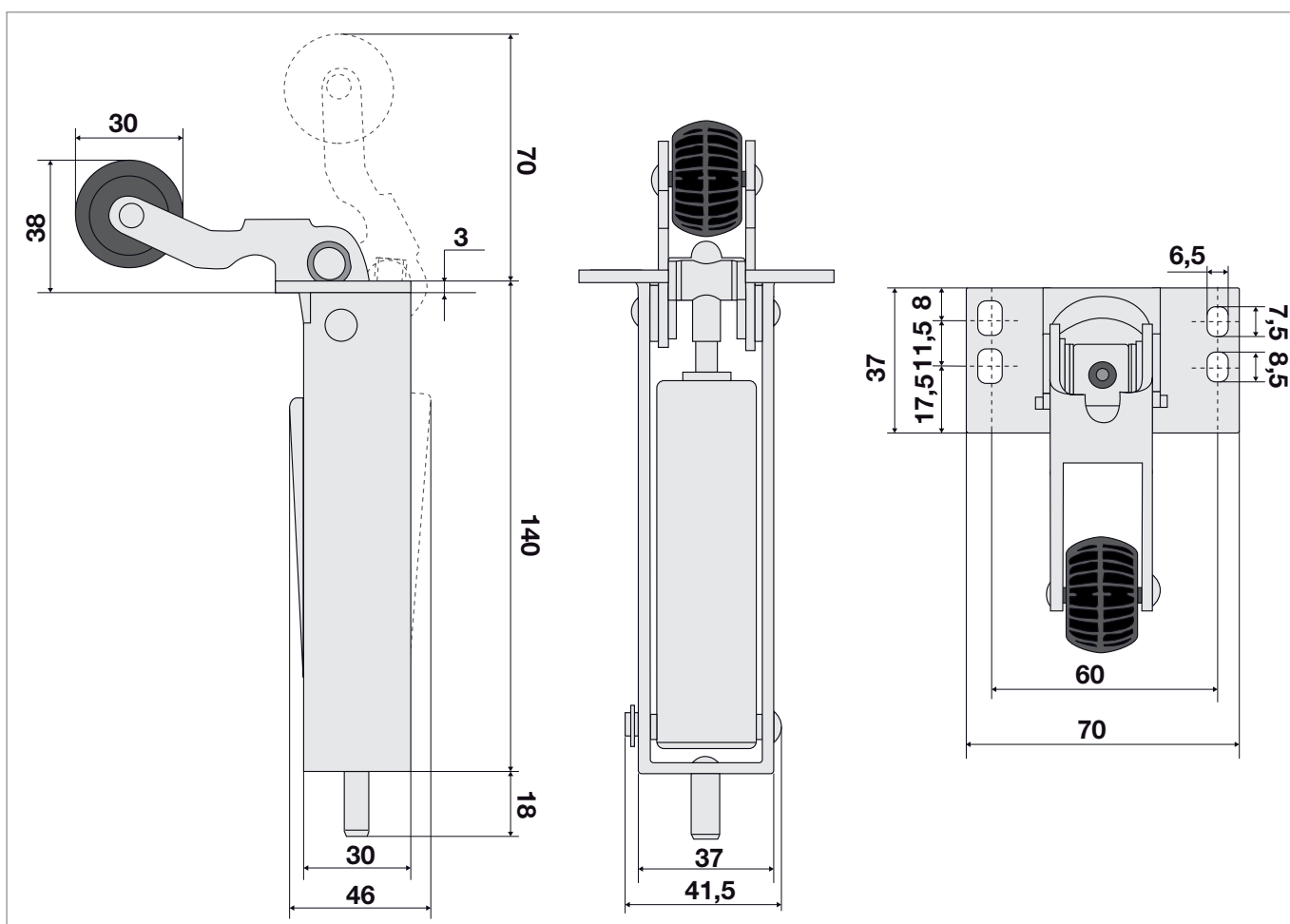

Codice / Code	Forza / Force	Descrizione / Description
100012	50 N	Chiudiporta Dictator standard ORONA

CHIUDIPIORTA DICTATOR STANDARD SCHINDLER DICTATOR LIFT DOOR DAMPER STANDARD SCHINDLER



Chiudiporta Dictator standard "SCHINDLER"

1. Decelerazione progressiva
2. Regolazione semplice: girando in senso orario aumenta la decelerazione, girando in senso antiorario diminuisce la decelerazione
3. Bronzine in metallo autolubrificante
4. Olio atermico
5. Cilindro ricavato da unico pezzo
6. Rotella in gomma antiusura con bronzina
7. Impianto robotizzato per collaudo del 100% dei chiudiporta prodotti

Dictator lift door damper standard "SCHINDLER"

1. Deceleration progressive
2. Simple adjustment: turning clockwise increase the damping, turning counter clockwise decrease the progressive damping
3. Bearings in autolubricant
4. Atermic oil
5. Cylinder made from a unique piece
6. Wear-resistant rubber roller with bearing
7. Robotic system for testing 100% of door closers products

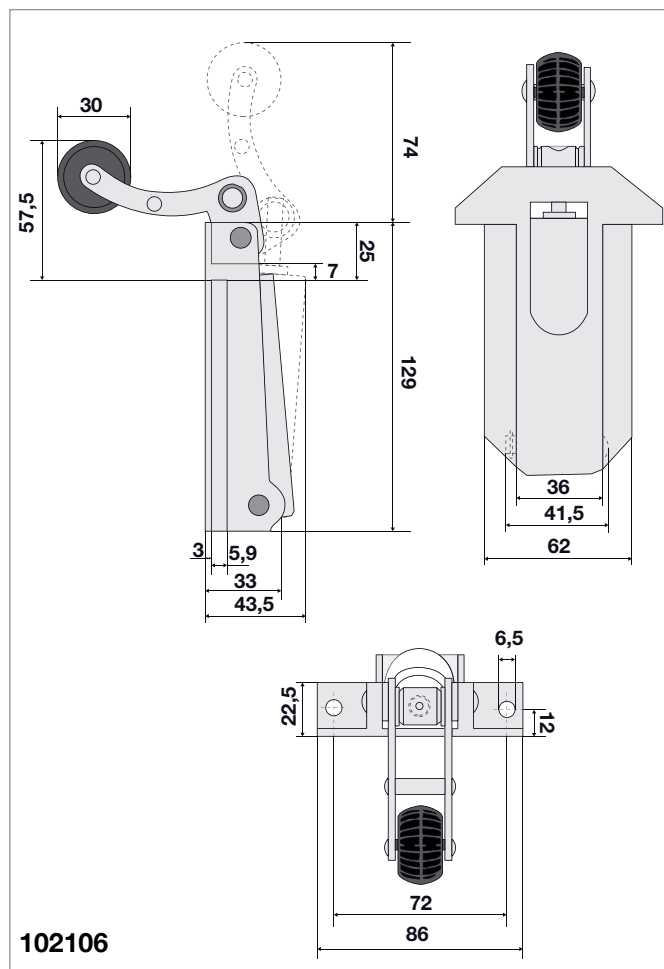
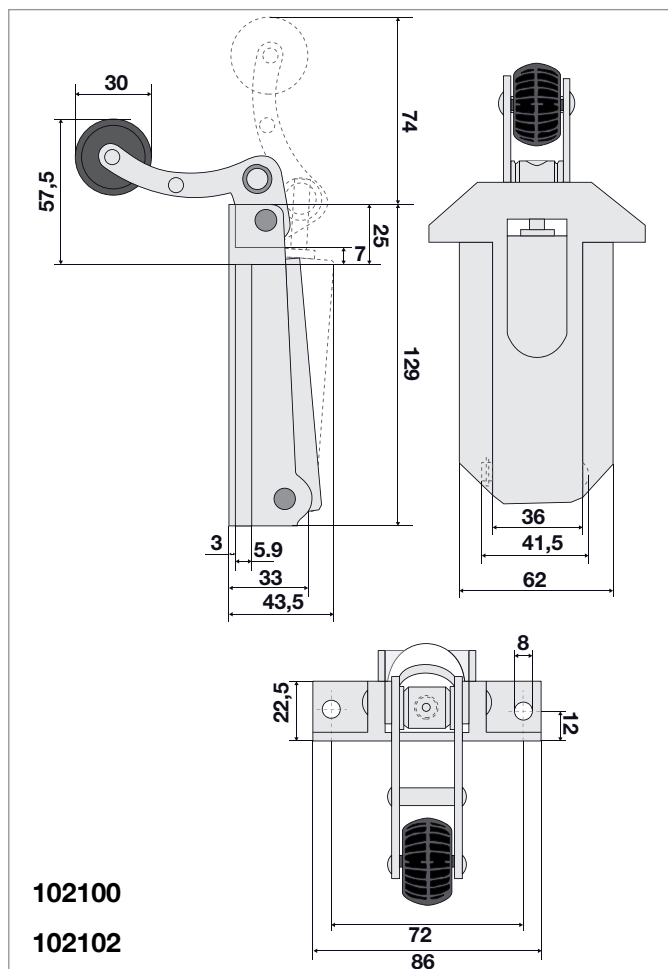

Codice / Code	Forza / Force	Descrizione / Description
102100	50 N	Chiudiporta Dictator standard SCHINDLER Fori di fissaggio \varnothing 8 mm
102102	80 N	Chiudiporta Dictator standard SCHINDLER Fori di fissaggio \varnothing 8 mm
102106	50 N	Chiudiporta Dictator standard SCHINDLER Fori di fissaggio \varnothing 6,5 mm

CHIUDIPIORTA DICTATOR STANDARD BASSETTI

DICTATOR LIFT DOOR DAMPER STANDARD BASSETTI



Chiudiporta Dictator standard "BASSETTI"

1. Decelerazione progressiva
2. Regolazione semplice: girando in senso orario aumenta la decelerazione, girando in senso antiorario diminuisce la decelerazione
3. Bronzine in metallo autolubrificante
4. Olio atermico
5. Cilindro ricavato da unico pezzo
6. Rotella in gomma antiusura con bronzina
7. Impianto robotizzato per collaudo del 100% dei chiudiporta prodotti

Dictator lift door damper standard "BASSETTI"

1. Deceleration progressive
2. Simple adjustment: turning clockwise increase the damping, turning counter clockwise decrease the progressive damping
3. Bearings in autolubricant
4. Atermic oil
5. Cylinder made from a unique piece
6. Wear-resistant rubber roller with bearing
7. Robotic system for testing 100% of door closers products

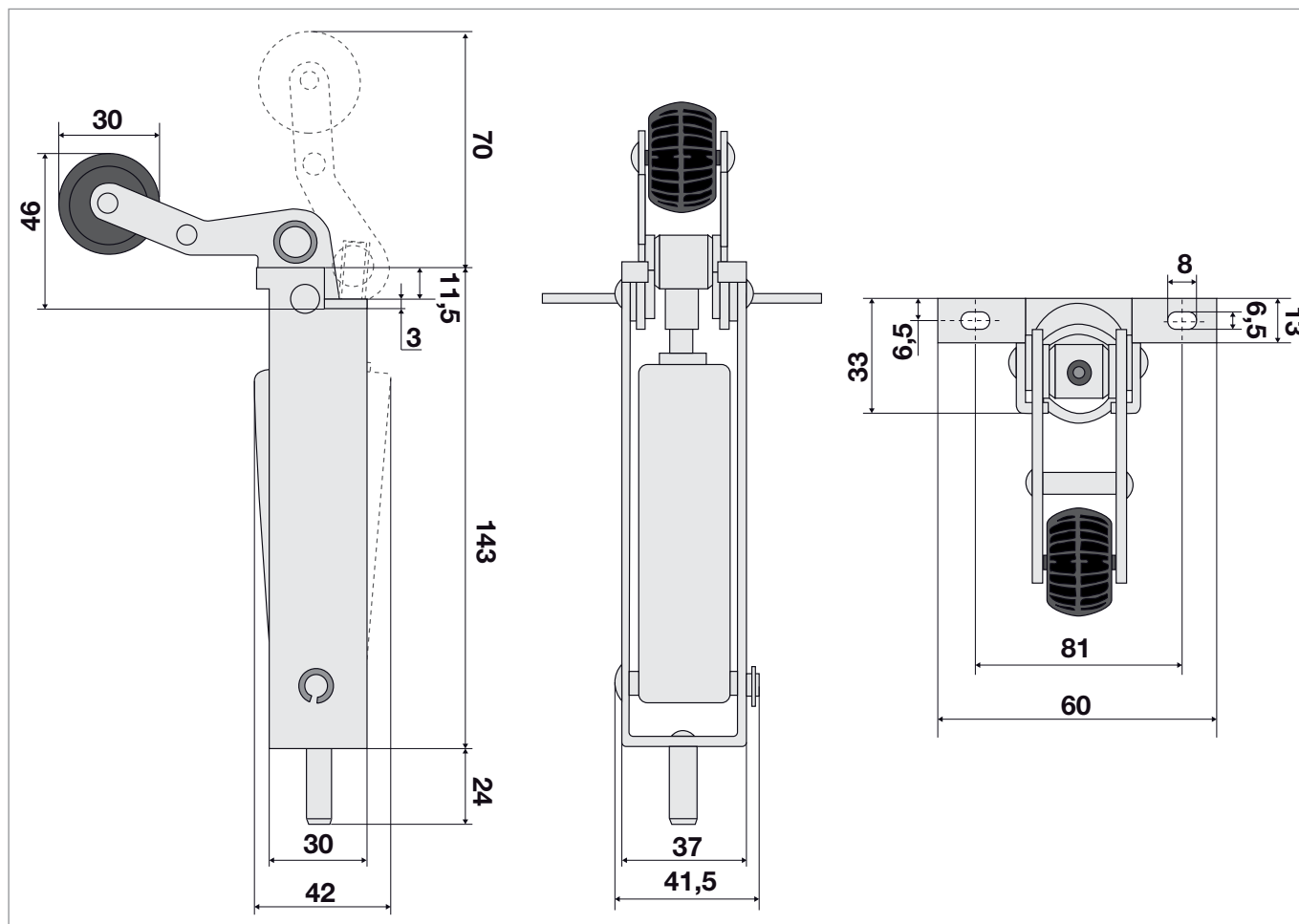

Codice / Code	Forza / Force	Descrizione / Description
100003	50 N	Chiudiporta Dictator standard BASSETTI

CHIUDIORTA DICTATOR STANDARD VIFIAM ROTELLA DIAM. 24 MM DICTATOR LIFT DOOR DAMPER STANDARD VIFIAM DIAM. 24 MM



Chiudiporta Dictator standard "VIFIAM ROTELLA Ø 24 mm"

1. Decelerazione progressiva
2. Regolazione semplice: girando in senso orario aumenta la decelerazione, girando in senso antiorario diminuisce la decelerazione
3. Bronzine in metallo autolubrificante
4. Olio atermico
5. Cilindro ricavato da unico pezzo
6. Rotella in gomma antiusura con bronzina
7. Impianto robotizzato per collaudo del 100% dei chiudiporta prodotti

Dictator lift door damper standard "VIFIAM ROLLER Ø 24 mm"

1. Deceleration progressive
2. Simple adjustment: turning clockwise increase the damping, turning counter clockwise decrease the progressive damping
3. Bearings in autolubricant
4. Atermic oil
5. Cylinder made from a unique piece
6. Wear-resistant rubber roller with bearing
7. Robotic system for testing 100% of door closers products

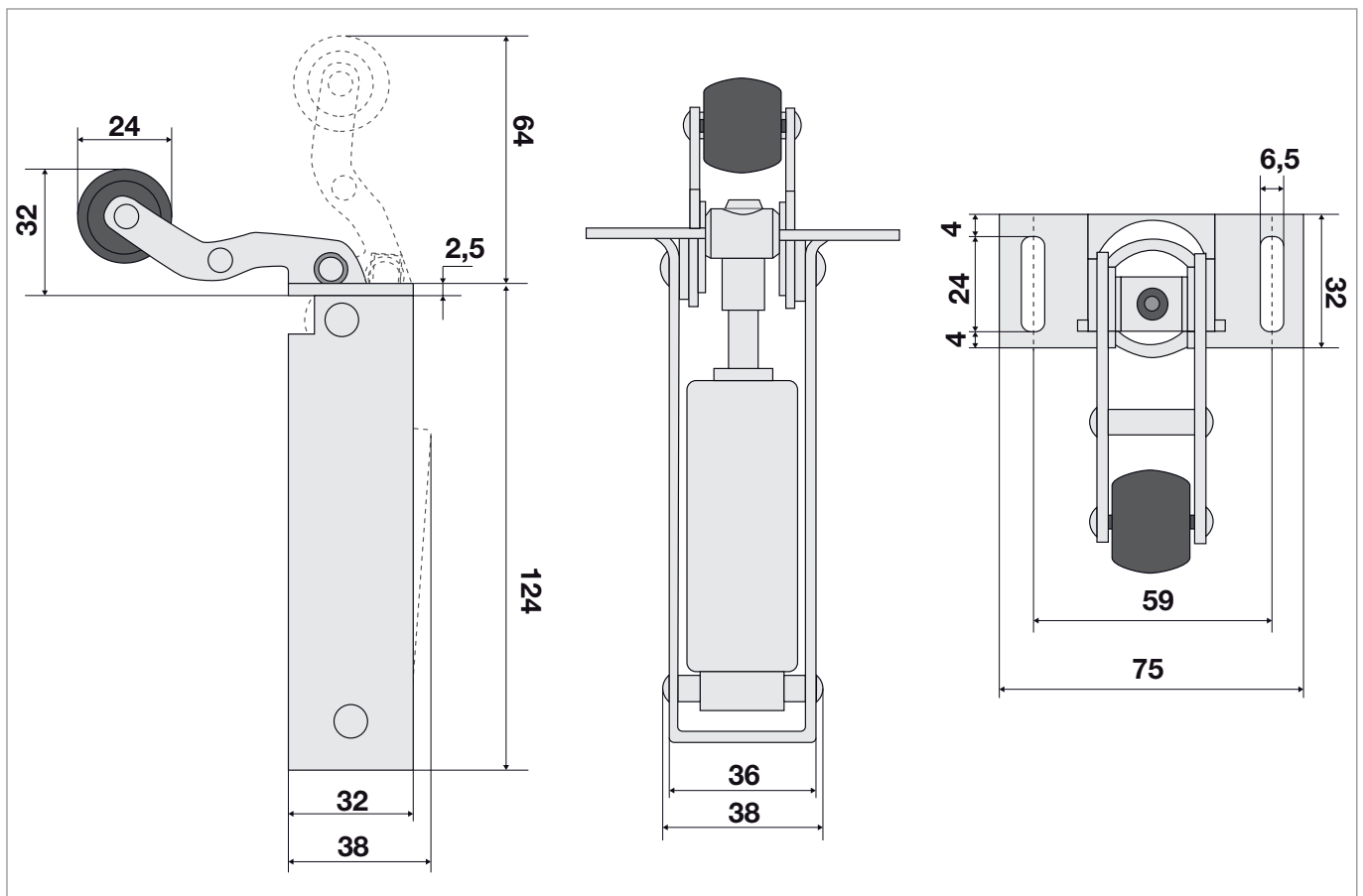

Codice / Code	Forza / Force	Descrizione / Description
100006	43 N	Chiudiporta Dictator standard VIFIAM rotella ø 24 mm

CHIUDIPIORTA DICTATOR STANDARD VIFIAM DIAM. 30 MM DICTATOR LIFT DOOR DAMPER STANDARD VIFIAM DIAM. 30 MM



Chiudiporta Dictator "STANDARD VIFIAM ROTELLA Ø 30 mm"

1. Decelerazione progressiva
2. Regolazione semplice: girando in senso orario aumenta la decelerazione, girando in senso antiorario diminuisce la decelerazione
3. Bronzine in metallo autolubrificante
4. Olio atermico
5. Cilindro ricavato da unico pezzo
6. Rotella in gomma antiusura con bronzina
7. Impianto robotizzato per collaudo del 100% dei chiudiporta prodotti

Dictator lift door damper standard "VIFIAM ROLLER Ø 30 mm"

1. Deceleration progressive
2. Simple adjustment: turning clockwise increase the damping, turning counter clockwise decrease the progressive damping
3. Bearings in autolubricant
4. Atermic oil
5. Cylinder made from a unique piece
6. Wear-resistant rubber roller with bearing
7. Robotic system for testing 100% of door closers products

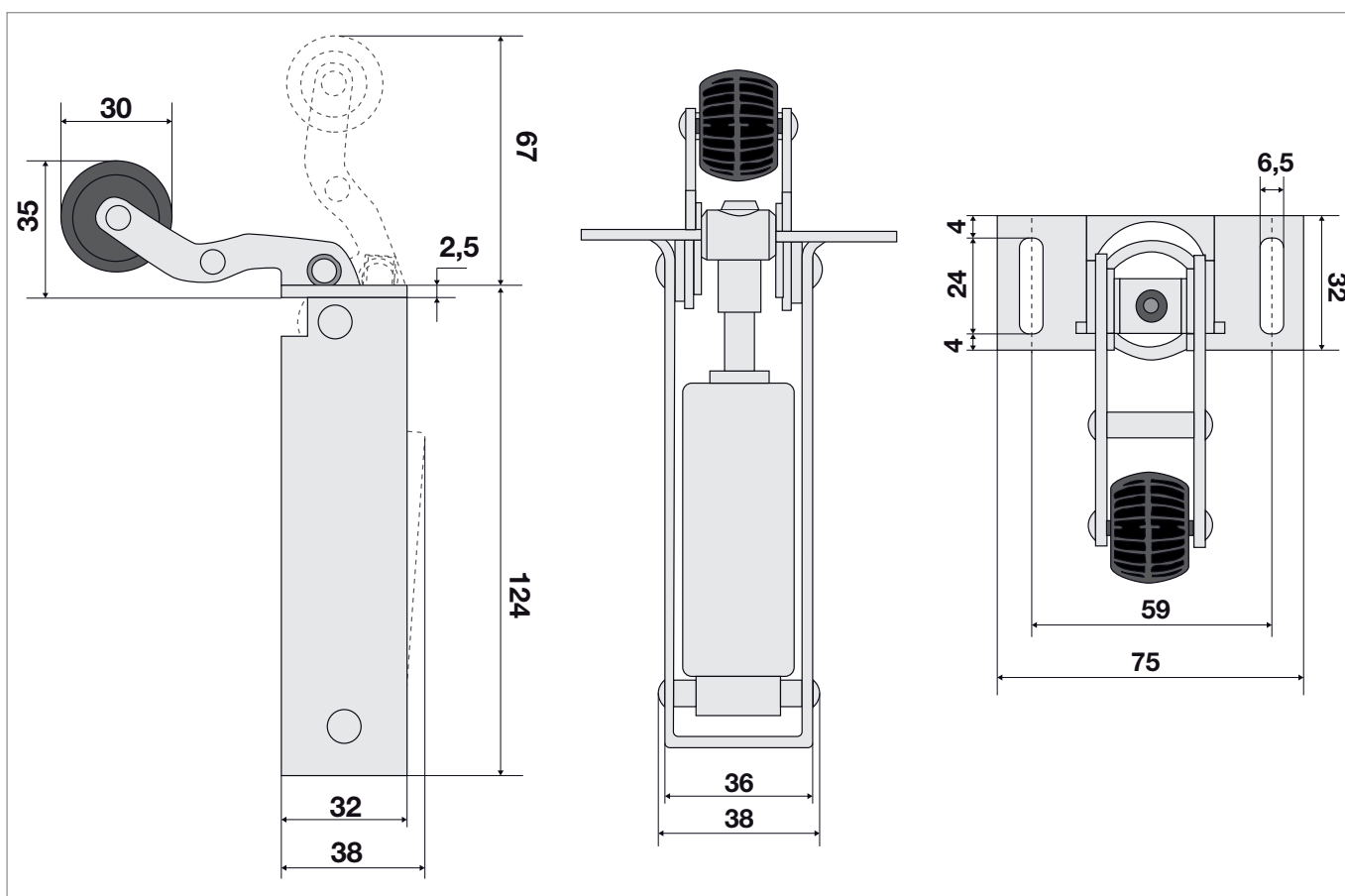

Codice / Code	Forza / Force	Descrizione / Description
100007	43 N	Chiudiporta Dictator standard VIFIAM rotella ø 30 mm

CHIUDIPIORTA DICTATOR STANDARD VIFIAM AV101 DICTATOR LIFT DOOR DAMPER STANDARD VIFIAM AV101



Chiudiporta Dictator standard "VIFIAM AV101"

1. Decelerazione progressiva
2. Regolazione semplice: girando in senso orario aumenta la decelerazione, girando in senso antiorario diminuisce la decelerazione
3. Bronzine in metallo autolubrificante
4. Olio atermico
5. Cilindro ricavato da unico pezzo
6. Rotella in gomma antiusura con bronzina
7. Impianto robotizzato per collaudo del 100% dei chiudiporta prodotti

Dictator lift door damper standard "VIFIAM AV101"

1. Deceleration progressive
2. Simple adjustment: turning clockwise increase the damping, turning counter clockwise decrease the progressive damping
3. Bearings in autolubricant
4. Atermic oil
5. Cylinder made from a unique piece
6. Wear-resistant rubber roller with bearing
7. Robotic system for testing 100% of door closers products

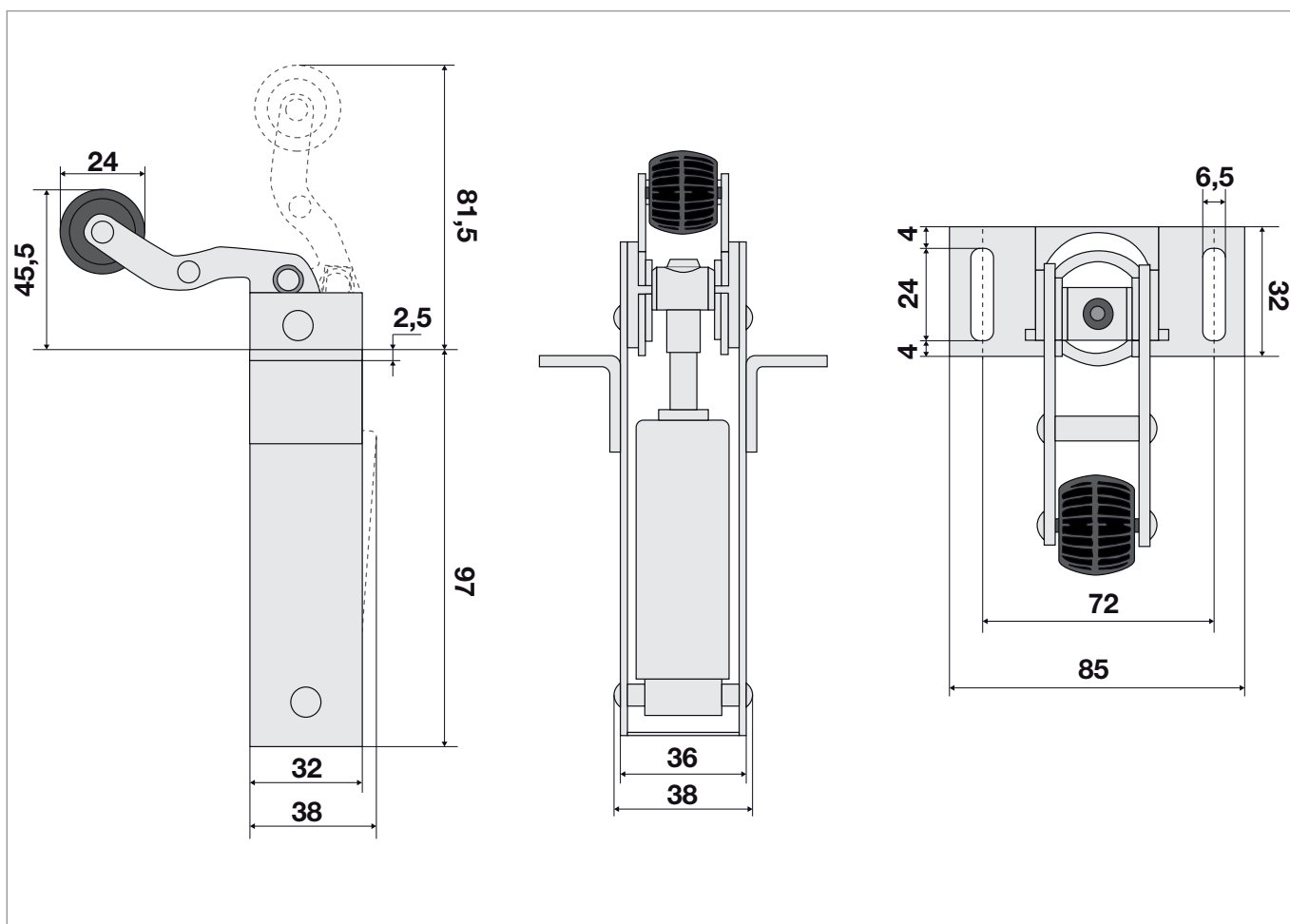

Codice / Code	Forza / Force	Descrizione / Description
100006/101	40 N	Chiudiporta Dictator standard VIFIAM AV101

CHIUDIPIORTA DICTATOR STANDARD SAFOV A SFIORAMENTO ALTO DICTATOR LIFT DOOR DAMPER STANDARD SAFOV HIGH TOUCH



Chiudiporta Dictator standard "SAFOV A SFIORAMENTO ALTO"

1. Decelerazione progressiva
2. Regolazione semplice: girando in senso orario aumenta la decelerazione, girando in senso antiorario diminuisce la decelerazione
3. Bronzine in metallo autolubrificante
4. Olio atermico
5. Cilindro ricavato da unico pezzo
6. Rotella in gomma antiusura con bronzina
7. Impianto robotizzato per collaudo del 100% dei chiudiporta prodotti

Dictator lift door damper standard "SAFOV HIGH TOUCH"

1. Deceleration progressive
2. Simple adjustment: turning clockwise increase the damping, turning counter clockwise decrease the progressive damping
3. Bearings in autolubricant
4. Atermic oil
5. Cylinder made from a unique piece
6. Wear-resistant rubber roller with bearing
7. Robotic system for testing 100% of door closers products

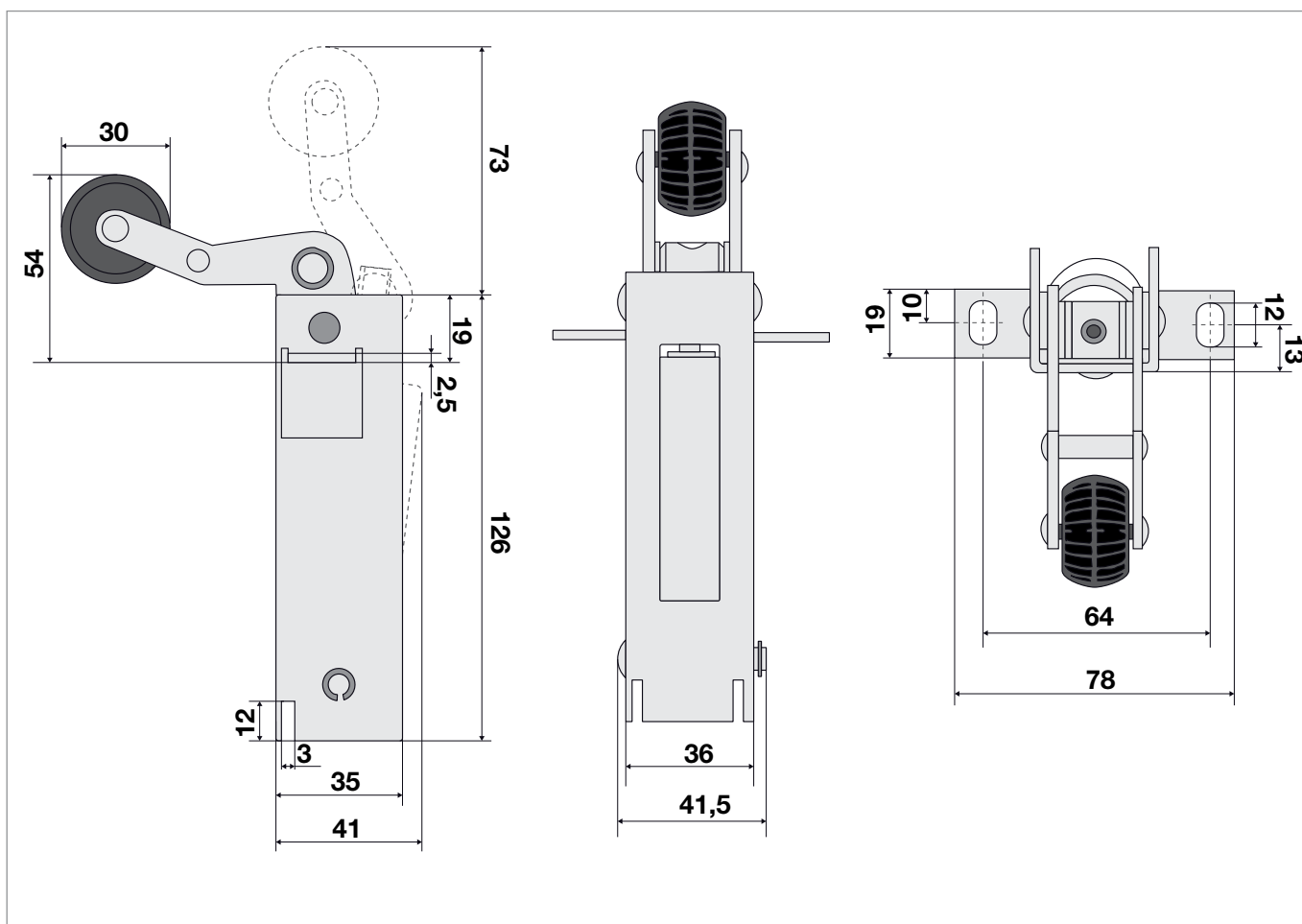

Codice / Code	Forza / Force	Descrizione / Description
100017	50 N	Chiudiporta Dictator standard SAFOV S.A.

CHIUDIPIORTA DICTATOR STANDARD SAFOV SFIORAMENTO BASSO DICTATOR LIFT DOOR DAMPER STANDARD SAFOV LOW TOUCH



Chiudiporta Dictator standard "SAFOV SFIORAMENTO BASSO"

1. Decelerazione progressiva
2. Regolazione semplice: girando in senso orario aumenta la decelerazione, girando in senso antiorario diminuisce la decelerazione
3. Bronzine in metallo autolubrificante
4. Olio atermico
5. Cilindro ricavato da unico pezzo
6. Rotella in gomma antiusura con bronzina
7. Impianto robotizzato per collaudo del 100% dei chiudiporta prodotti

Dictator lift door damper standard "SAFOV LOW TOUCH"

1. Deceleration progressive
2. Simple adjustment: turning clockwise increase the damping, turning counter clockwise decrease the progressive damping
3. Bearings in autolubricant
4. Atermic oil
5. Cylinder made from a unique piece
6. Wear-resistant rubber roller with bearing
7. Robotic system for testing 100% of door closers products

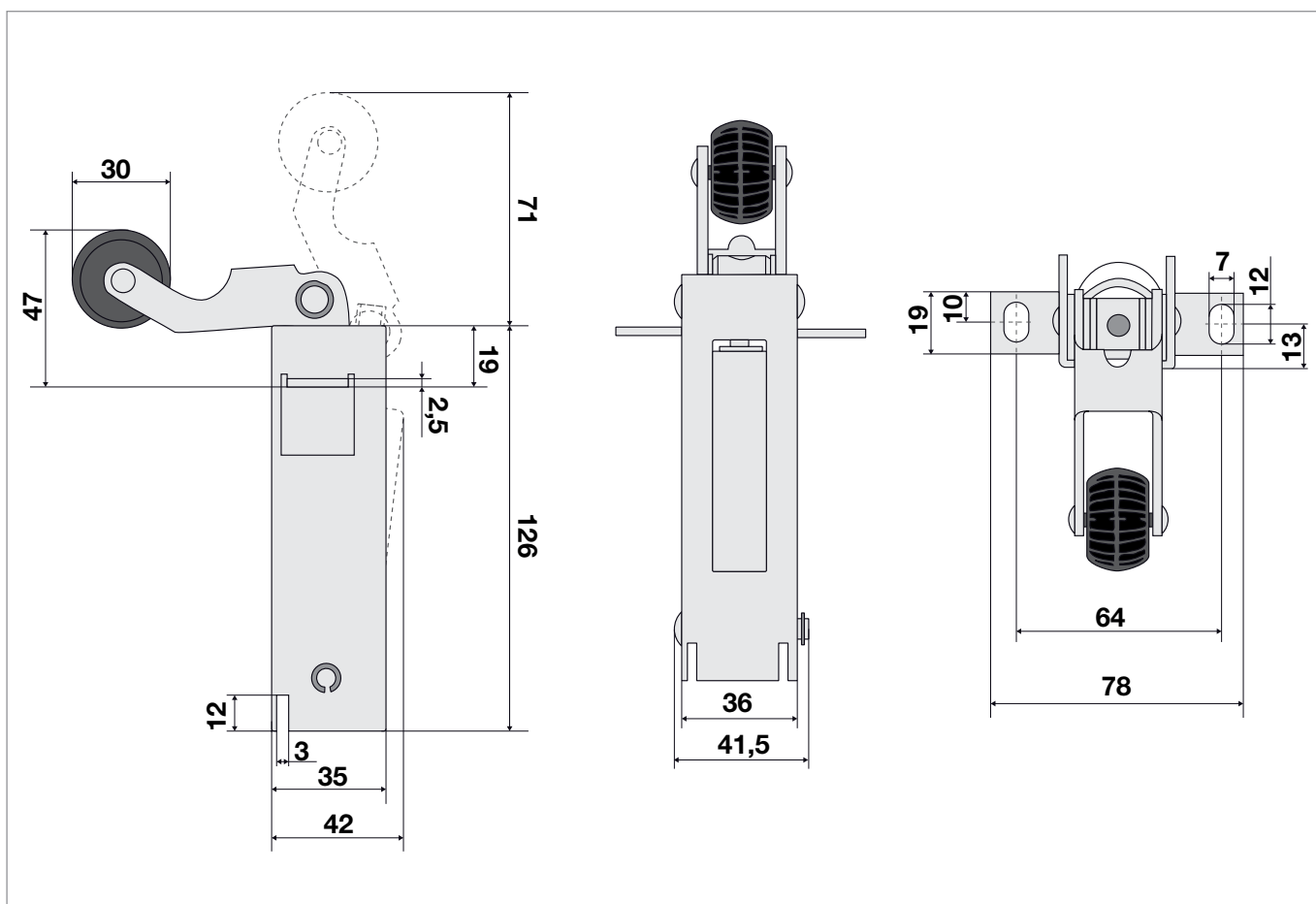

Codice / Code	Forza / Force	Descrizione / Description
100008	50 N	Chiudiporta Dictator standard SAFOV S.B.

CHIUDIPIORTA DICTATOR STANDARD SAFOV PER OPERATORE DICTATOR LIFT DOOR DAMPER STANDARD SAFOV FOR DOOR OPERATOR



Chiudiporta Dictator standard "SAFOV PER OPERATORE"

1. Decelerazione progressiva
2. Regolazione semplice: girando in senso orario aumenta la decelerazione, girando in senso antiorario diminuisce la decelerazione
3. Bronzine in metallo autolubrificante
4. Olio atermico
5. Cilindro ricavato da unico pezzo
6. Rotella in gomma antiusura con bronzina
7. Impianto robotizzato per collaudo del 100% dei chiudiporta prodotti

Dictator lift door damper standard "SAFOV FOR DOOR OPERATOR"

1. Deceleration progressive
2. Simple adjustment: turning clockwise increase the damping, turning counter clockwise decrease the progressive damping
3. Bearings in autolubricant
4. Atermic oil
5. Cylinder made from a unique piece
6. Wear-resistant rubber roller with bearing
7. Robotic system for testing 100% of door closers products

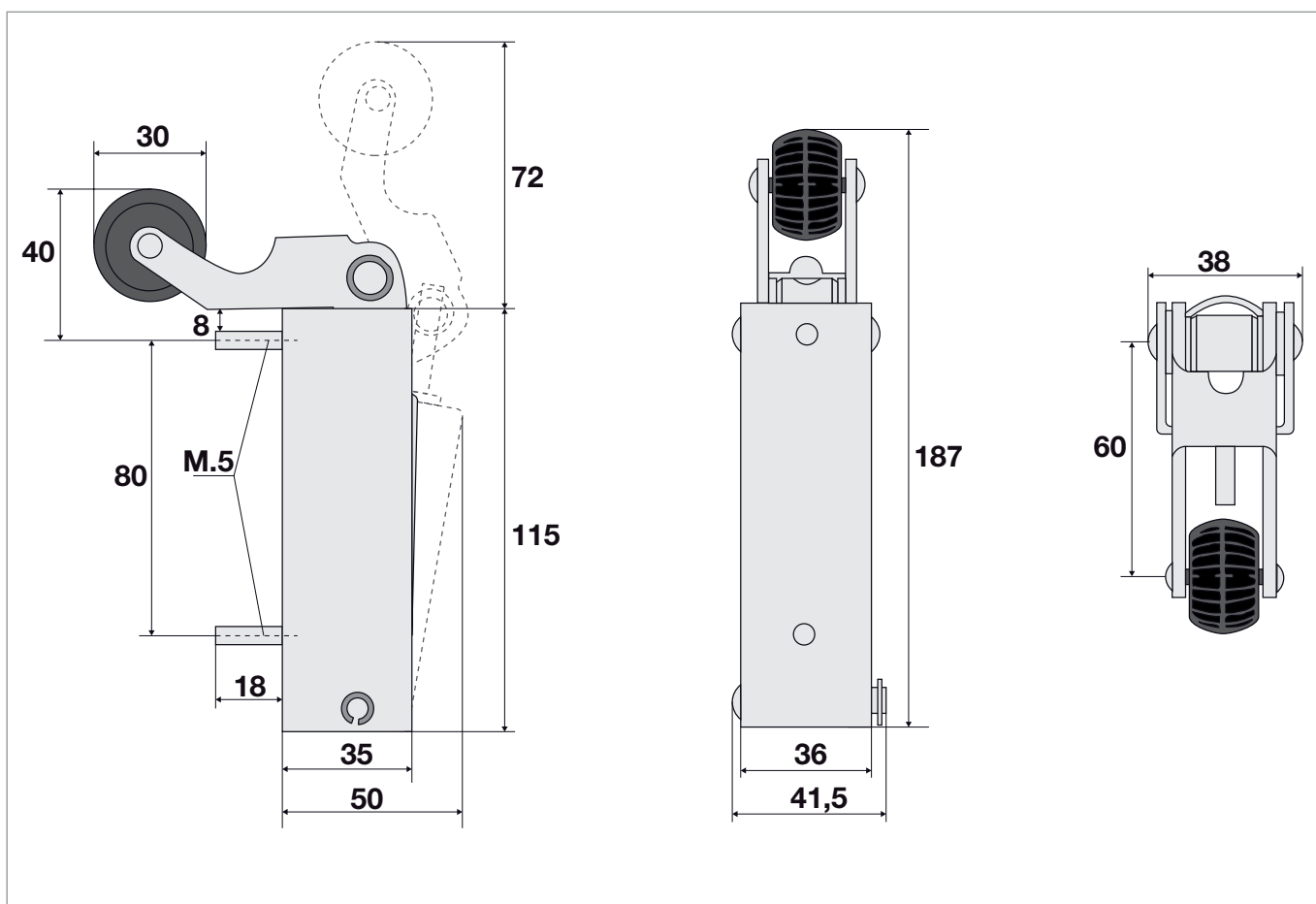

Codice / Code	Forza / Force	Descrizione / Description
100018	50 N	Chiudiporta Dictator standard SAFOV per operatore
100018/1	30 N	Chiudiporta Dictator standard SAFOV per operatore

CHIUDIPIORTA DICTATOR SAFOV PER OPERATORE DOPPIA ROTELLA DICTATOR LIFT DOOR DAMPER SAFOV FOR DOOR OPERATOR DOUBLE ROLLER



Chiudiporta Dictator "SAFOV PER OPERATORE DOPPIA ROTELLA"

1. Decelerazione progressiva
2. Regolazione semplice: girando in senso orario aumenta la decelerazione, girando in senso antiorario diminuisce la decelerazione
3. Bronzine in metallo autolubrificante
4. Olio atermico
5. Cilindro ricavato da unico pezzo
6. Rotella in gomma antiusura con bronzina
7. Impianto robotizzato per collaudo del 100% dei chiudiporta prodotti

Dictator lift door damper "SAFOV FOR DOOR OPERATOR DOUBLE ROLLER"

1. Deceleration progressive
2. Simple adjustment: turning clockwise increase the damping, turning counter clockwise decrease the progressive damping
3. Bearings in autolubricant
4. Atermic oil
5. Cylinder made from a unique piece
6. Wear-resistant rubber roller with bearing
7. Robotic system for testing 100% of door closers products

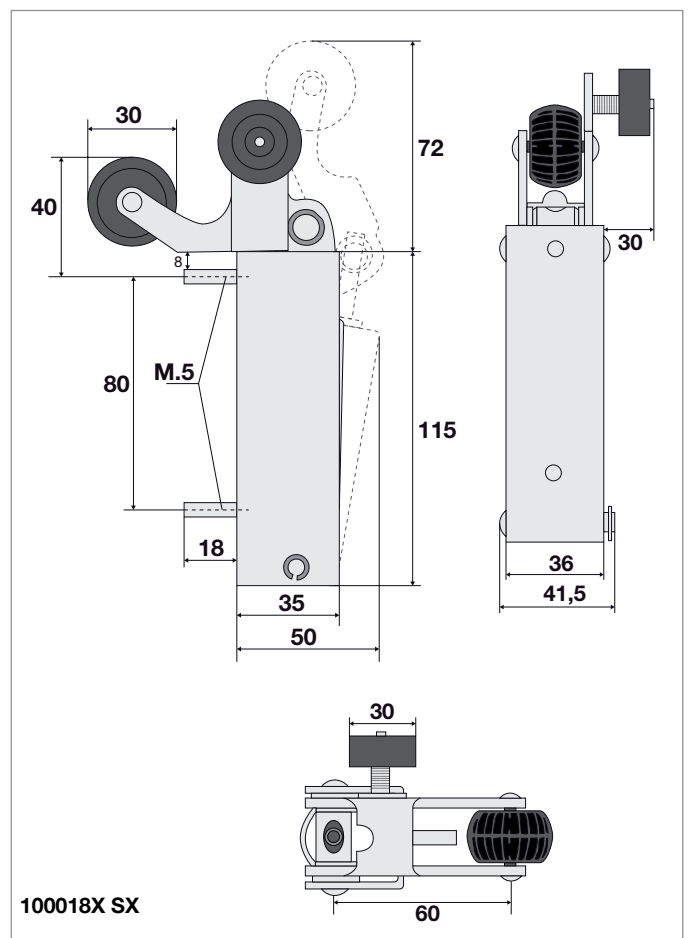
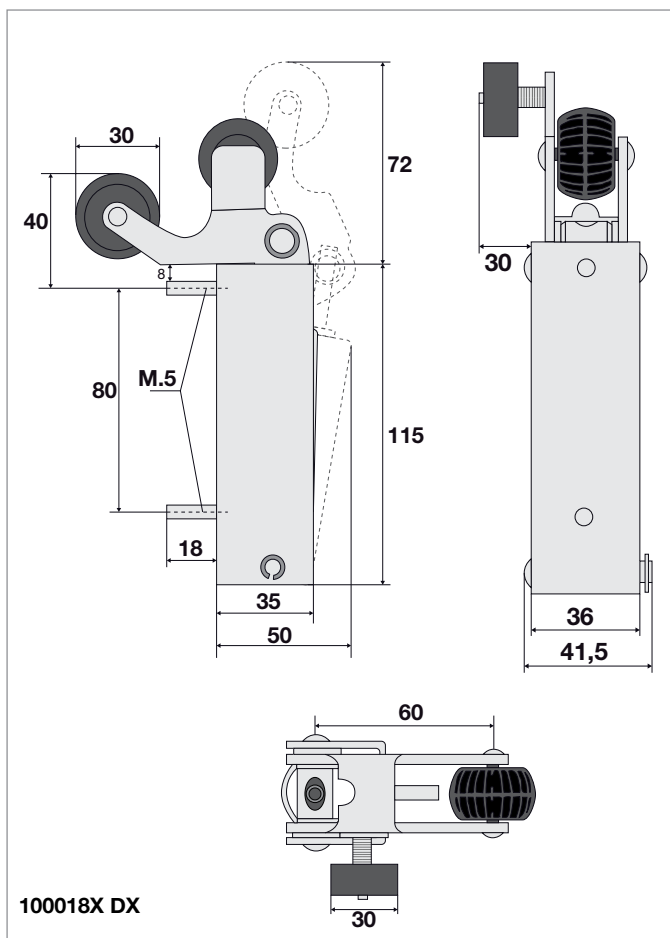

Raffigurato chiudiporta per porta apertura a destra e chiusura a sinistra vista dal pianerottolo

Codice / Code	Forza / Force	Descrizione / Description
100018X DX	40 N	Chiudiporta Dictator standard SAFOV per operatore a doppia rotella destra
100018X SX	40 N	Chiudiporta Dictator standard SAFOV per operatore a doppia rotella sinistra

CHIUDIORTA DICTATOR SAFOV PER PORTINE DI CABINA (SOTTO ALLA CABINA)

DICTATOR LIFT DOOR DAMPER SAFOV FOR CABIN DOORS (UNDER THE CABIN)



Chiudiporta Dictator "SAFOV PER PORTINE DI CABINA (SOTTO ALLA CABINA)"

1. Decelerazione progressiva
2. Regolazione semplice: girando in senso orario aumenta la decelerazione, girando in senso antiorario diminuisce la decelerazione
3. Bronzine in metallo autolubrificante
4. Olio atermico
5. Cilindro ricavato da unico pezzo
6. Rotella in gomma antiusura con bronzina
7. Impianto robotizzato per collaudo del 100% dei chiudiporta prodotti

Dictator lift door damper "SAFOV FOR CABIN DOORS (UNDER THE CABIN)"

1. Deceleration progressive
2. Simple adjustment: turning clockwise increase the damping, turning counter clockwise decrease the progressive damping
3. Bearings in autolubricant
4. Atermic oil
5. Cylinder made from a unique piece
6. Wear-resistant rubber roller with bearing
7. Robotic system for testing 100% of door closers products

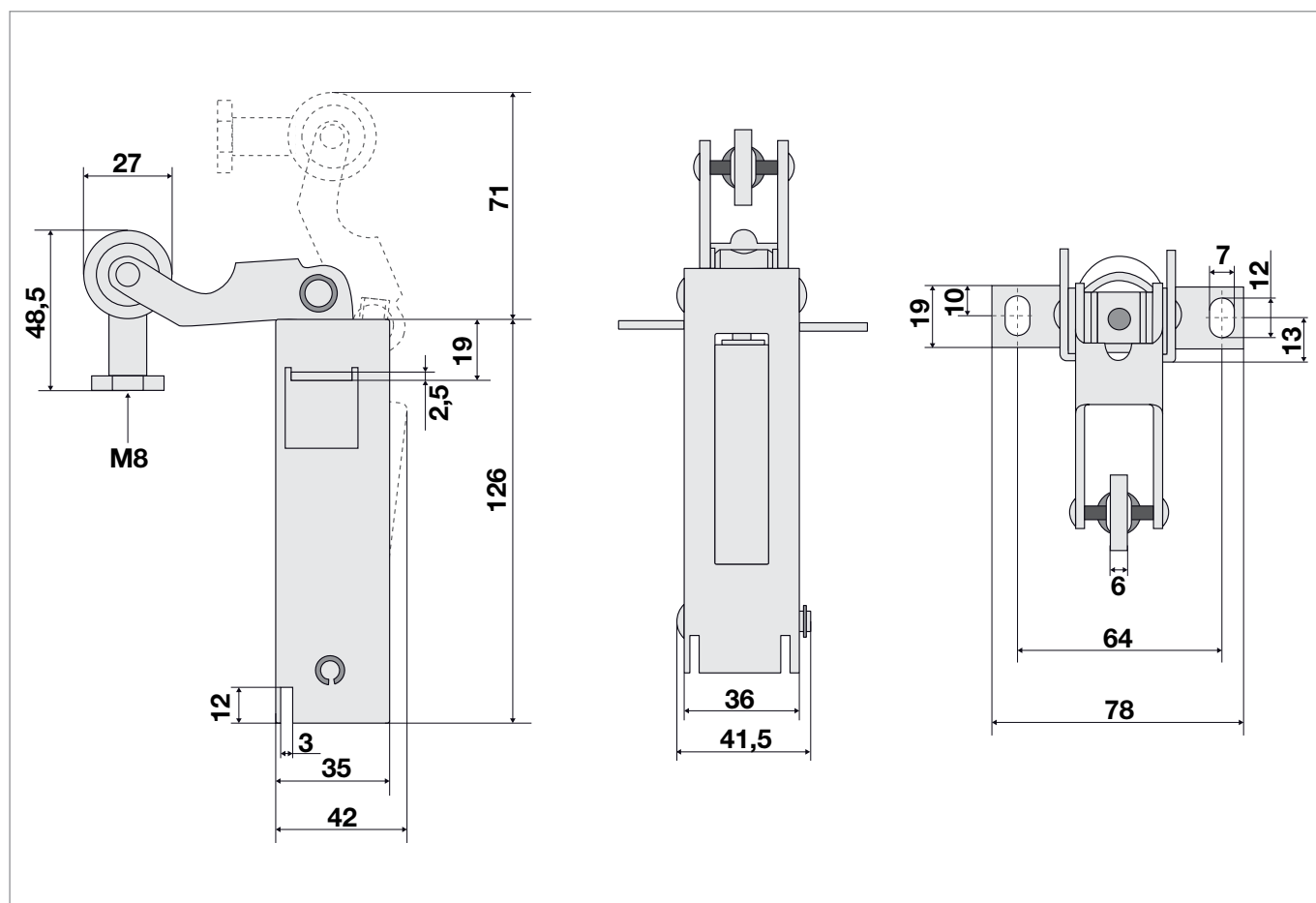

Codice / Code	Forza / Force	Descrizione / Description
100008X	50 N	Chiudiporta Dictator SAFOV per portine di cabina (sotto alla cabina)

CHIUDIPIORTA DICTATOR STANDARD CIOCCA DICTATOR LIFT DOOR DAMPER STANDARD CIOCCA



Chiudiporta Dictator standard "CIOCCA"

1. Decelerazione progressiva
2. Regolazione semplice: girando in senso orario aumenta la decelerazione, girando in senso antiorario diminuisce la decelerazione
3. Bronzine in metallo autolubrificante
4. Olio atermico
5. Cilindro ricavato da unico pezzo
6. Rotella in gomma antiusura con bronzina
7. Impianto robotizzato per collaudo del 100% dei chiudiporta prodotti

Dictator lift door damper standard "CIOCCA"

1. Deceleration progressive
2. Simple adjustment: turning clockwise increase the damping, turning counter clockwise decrease the progressive damping
3. Bearings in autolubricant
4. Atermic oil
5. Cylinder made from a unique piece
6. Wear-resistant rubber roller with bearing
7. Robotic system for testing 100% of door closers products

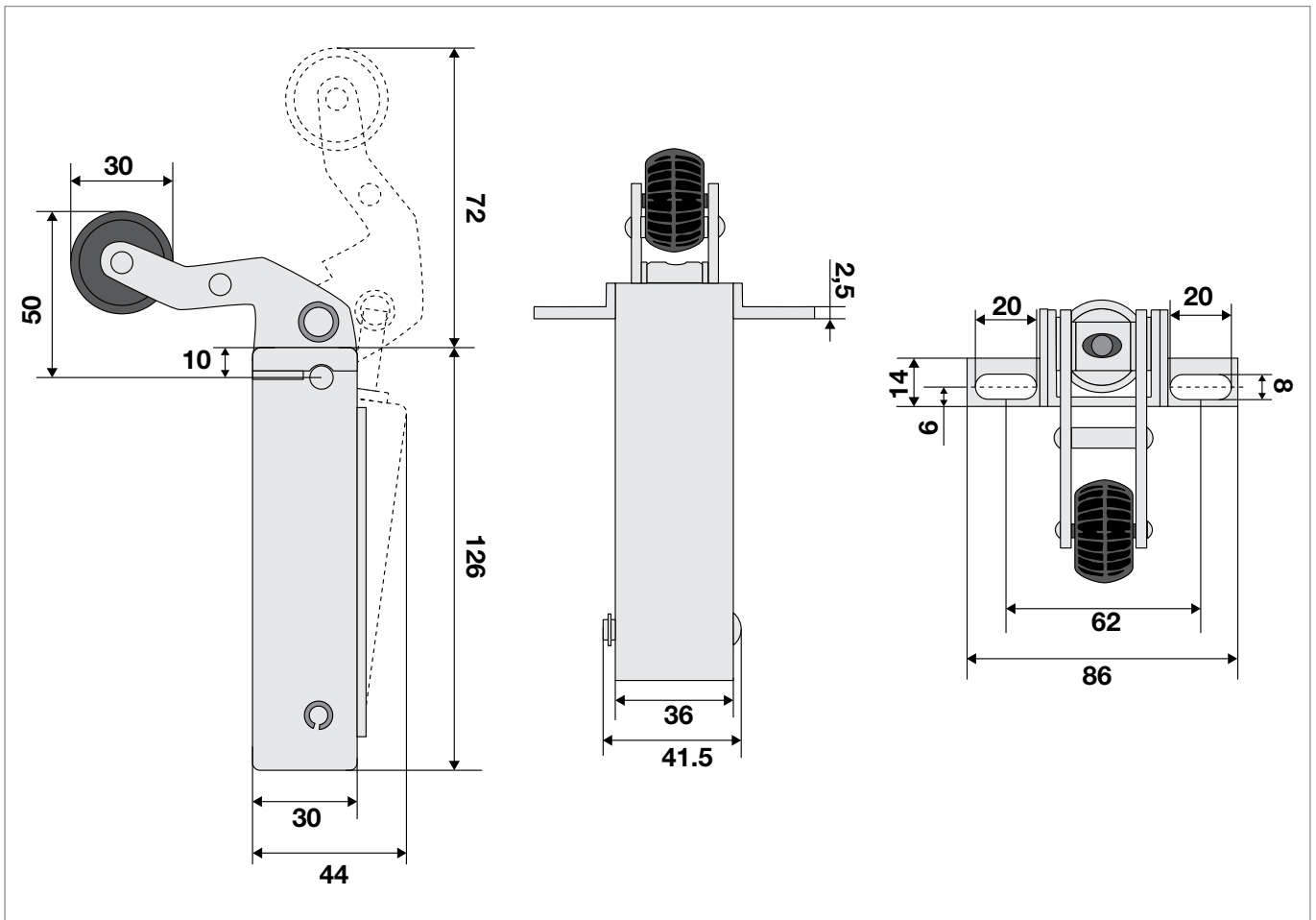

Codice / Code	Forza / Force	Descrizione / Description
102750	50 N	Chiudiporta Dictator standard CIOCCA

CHIUDIORTA DICTATOR TIPO VI.MEC ROTELLA IN BASSO DICTATOR LIFT DOOR DAMPER VI.MEC ROLLER IN LOWER POSITION



Chiudiporta Dictator tipo "VI.MEC ROTELLA IN BASSO"

1. Decelerazione progressiva
2. Regolazione fissa della casa specifico per montaggio con ruota in basso
3. Bronzine in metallo autolubrificante
4. Olio atermico
5. Cilindro ricavato da unico pezzo
6. Rotella in gomma antiusura con bronzina
7. Impianto robotizzato per collaudo del 100% dei chiudiporta prodotti

Dictator lift door damper "VI.MEC ROLLER IN LOWER POSITION"

1. Deceleration progressive
2. Fixed adjustment specific for mounting with roller down
3. Bearings in autolubricant
4. Atermic oil
5. Cylinder made from a unique piece
6. Wear-resistant rubber roller with bearing
7. Robotic system for testing 100% of door closers products

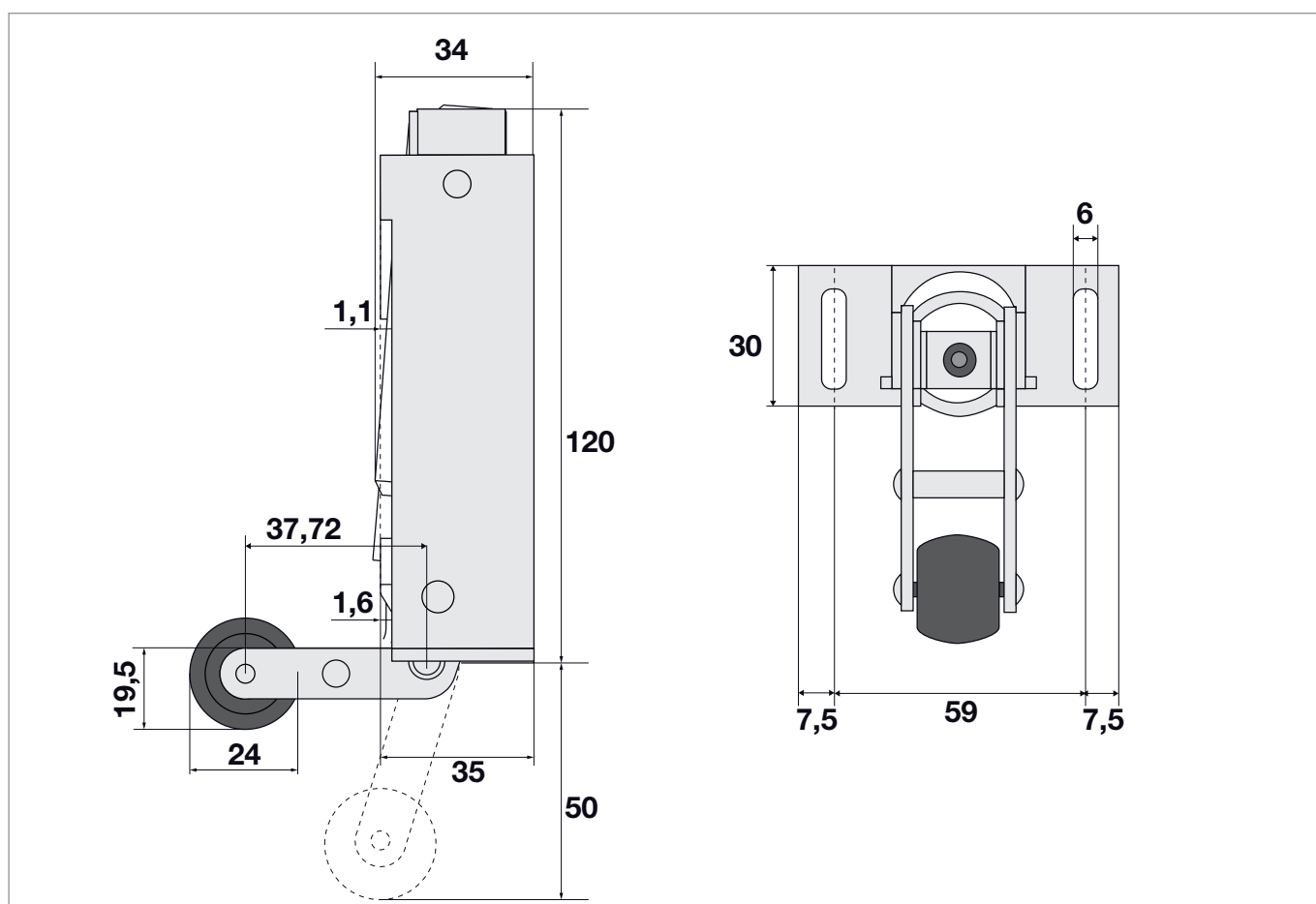

Codice / Code	Forza / Force	Descrizione / Description
100036	60 N	Chiudiporta Dictator tipo VI.MEC rotella in basso. Specifico per montaggio con rotella in basso

CHIUDIPIORTA DICTATOR STANDARD ESP (FERMATOR) DOOR CLOSER DICTATOR STANDARD ESP (FERMATOR)



Chiudiporta Dictator standard "STANDARD ESP"

1. Decelerazione progressiva
2. Regolazione semplice: girando in senso orario aumenta la decelerazione, girando in senso antiorario diminuisce la decelerazione
3. Bronzine in metallo autolubrificante
4. Olio atermico
5. Cilindro ricavato da unico pezzo
6. Rotella in gomma antiusura con bronzina
7. Impianto robotizzato per collaudo del 100% dei chiudiporta prodotti

Door closer Dictator "STANDARD ESP"

1. Deceleration progressive
2. Simple adjustment: turning clockwise increase the damping, turning counter clockwise decrease the progressive damping
3. Bearings in autolubricant
4. Atermic oil
5. Cylinder made from a unique piece
6. Wear-resistant rubber roller with bearing
7. Robotic system for testing 100% of door closers products

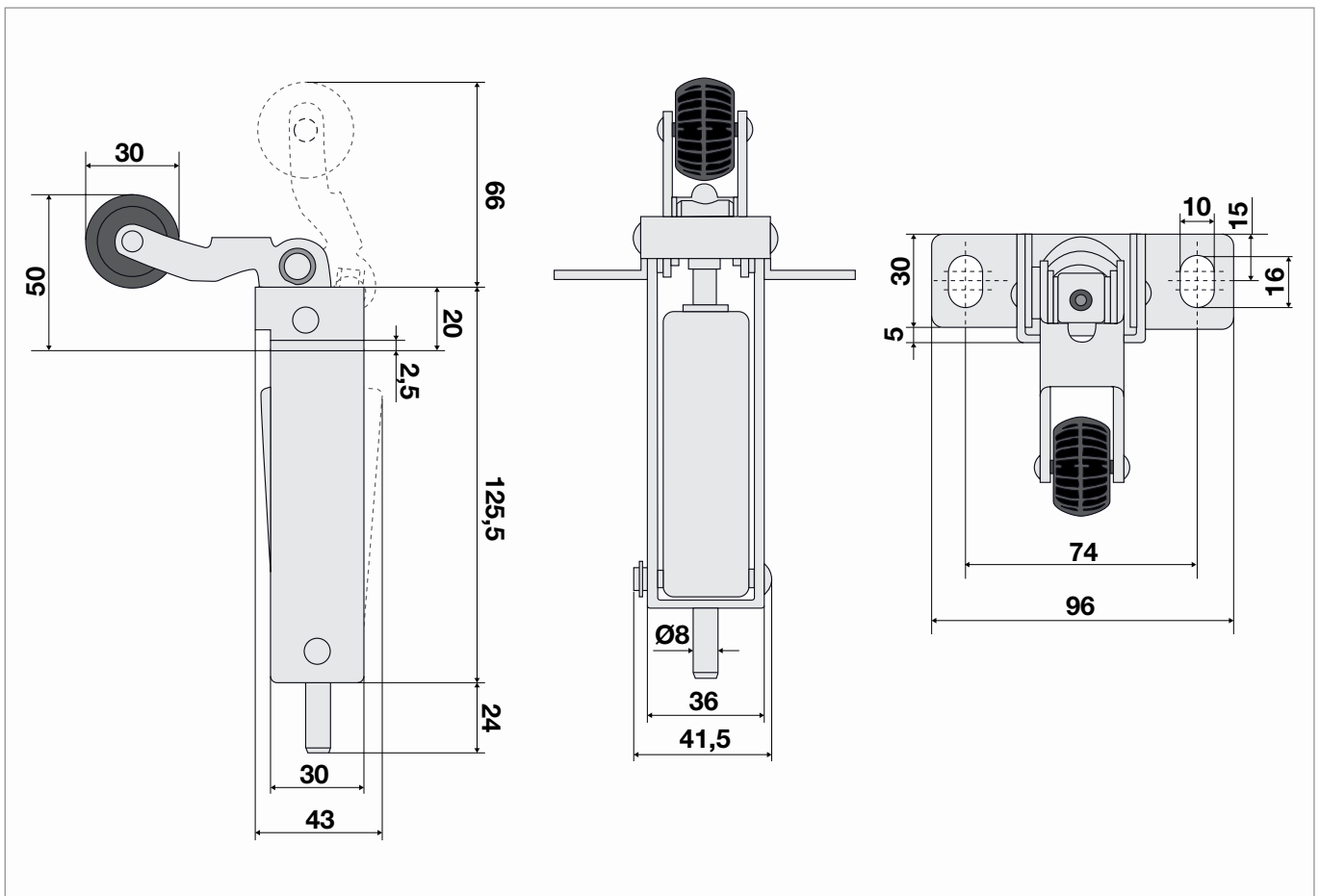

Codice / Code	Forza / Force	Descrizione / Description
105000	50 N	Chiudiporta Dictator standard ESP (FERMATOR)
105001	80 N	Chiudiporta Dictator standard ESP (FERMATOR)

CHIUDIPIORTA DICTATOR LS FZ DICTATOR LS FZ LIFT DOOR CLOSER



Il chiudiporta Dictator LS FZ è intercambiabile su porte FIAM e porte dotate di questo chiudiporta, come per esempio porte VICINI, ecc...
È dotato di paraolio sugli assi con O-ring (anello di tenuta).
Ogni chiudiporta viene consegnato con vite per leva (specificare se la rotella ha il fermo a 90°)

- per porte di larghezza inferiore a 600 mm utilizzare **cod. 205124**
- per porte di larghezza da 600 mm a 700 mm utilizzare **cod. 205121**

Dictator LS FZ door closer, it's interchangeable for FIAM doors and other doors which fitted with this, for example VICINI door, etc...

The seal is fitted on axis with O-ring (sealing ring).

Each door closer is delivered with screw for lever (To specify if the roller have been stopped at 90°)

- for doors width shorter than 600 mm use **cod. 205124**
- for doors width from 600 mm to 700 mm use **cod. 205121**

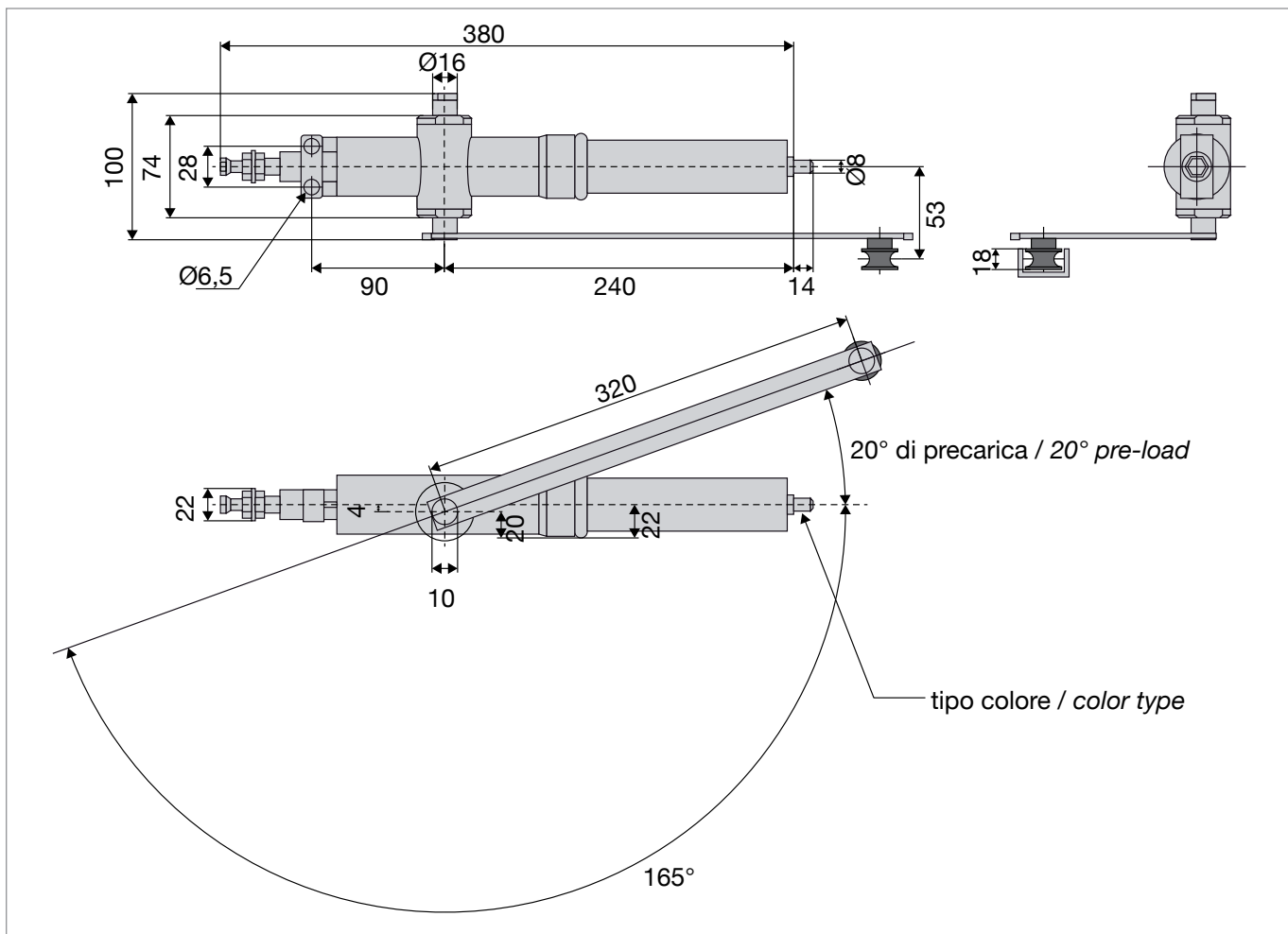

Codice / Code	Forza / Force	Descrizione / Description
205121	20-30 N	Chiudiporta Dictator LS FZ Colore ROSSO
205124	15-20 N	Chiudiporta Dictator LS FZ Colore BLU
205000	-	Leva per chiudiporta cod. 205121 e cod. 205124
205200V	-	Vite per leva cod. 205000

CHIUDIPIORTA DS RYOBI CO52 PER SOSTITUZIONE CHIUDIPIORTA DICTATOR LSFZ BLU (FORZA 15-20 N) SU PORTE CON CERNIERE USURATE DOOR CLOSER DS RYOBI CO52 FOR REPLACEMENT DICTATOR DOOR CLOSER LSFZ BLUE (FORCE 15-20 N) FOR DOOR WITH WORN HINGES



Quando le porte dove è montato il chiudiporta LS FZ tipo Blu non si chiudono nonostante sia stato montato un chiudiporta LS FZ nuovo codice 205124 significa che le porte hanno le cerniere troppo usurate.

In questo caso anziché sostituire le porte si installa il chiudiporta DS Ryobi CO52, perché avendo 2 registri di velocità separati si può dare il "colpo fine corsa" che supera l'attrito delle cerniere usurate.

Tempo di sostituzione soli 10 minuti grazie a fori di fissaggio sul chiudiporta già filettati e montaggio con 6 fori passanti in dima in alluminio del set accessori.

Dima spessore 10 mm con canotto da incastro nel foro albero del vecchio chiudiporta già nella porta.

Quindi vanno svasati i 2 fori per viti di registro.

La guida esistente rimane ed è pronta per il braccio del DS Ryobi CO52 senza modifiche.



When the doors where the LS FZ Blue door closer is mounted do not close even though a new LS FZ door closer code 205124 has been fitted, it means that the hinges are worn.

In this case, instead of replacing the doors, the DS Ryobi CO52 door closer can be installed, because having 2 separate speed registers you can give the "stroke limit" which overcomes the friction of the worn hinges.

Replacement time only 10 minutes thanks to already threaded fixing holes on the door closer, assembly with 6 pass-through holes in the aluminium template of the accessory set.

10 mm thick template with insert sleeve in the shaft hole of the old door closer already in the door.

Then the 2 holes for adjusting screws must be countersunk.

The existing rail remains and is ready for the DS Ryobi CO52 without modification.

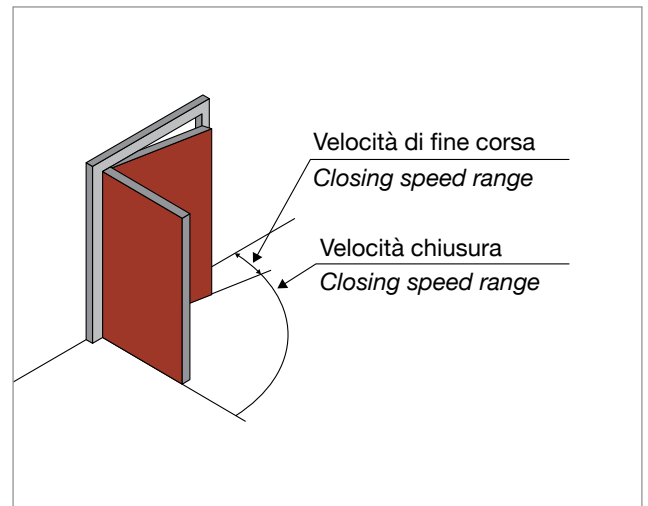
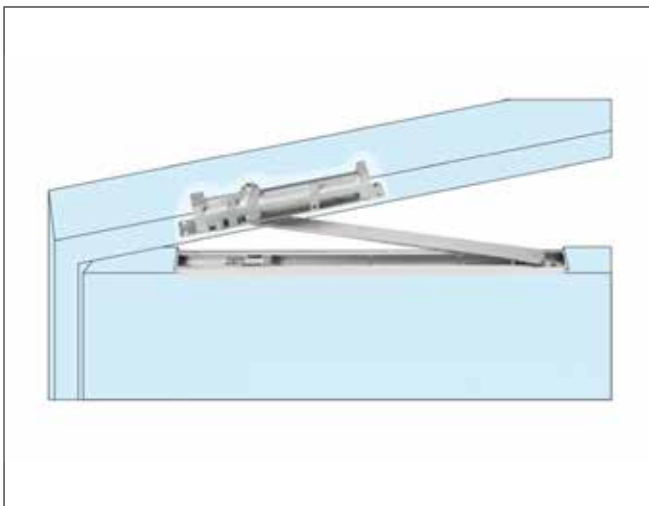

Codice / Code	Descrizione / Description
205124R	Chiudiporta Ds Ryobi CO52 con braccio - dima in alluminio - bulloneria - fascicolo istruzioni

CHIUDIPIORTA DS RYOBI CO52 PER SOSTITUZIONE FIAM FUORI PRODUZIONE
DOOR CLOSER DS RYOBI CO52 FOR REPLACEMENT FIAM OUT OF PRODUCTION

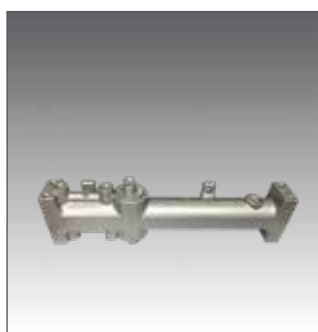

Il chiudiporta Ds Ryobi CO52 con set accessori (codice 205124IR) serve per la sostituzione del chiudiporta FIAM ormai irreperibile. Viene fornito con istruzioni di montaggio per la sostituzione ed è composto da chiudiporta braccio guida bulloneria e dima di foratura in alluminio.

Tempo di sostituzione soli 20 minuti grazie a fori di fissaggio sul chiudiporta già filettati, e montaggio con 6 fori passanti in dima in alluminio del set accessori.

Dima spessore 10 mm con canotto da incastro nel foro albero del vecchio chiudiporta già nella porta.

Quindi vanno svasati i 2 fori per viti di registro fissata la nuova guida e praticato un intaglio del bordo superiore della porta per passaggio braccio lato vano corsa.

The Ds Ryobi CO52 door closer with accessory set (code 205124IR) is used to replace the now replacement FIAM door closer. Comes with assembly instructions for replacement and is composed of door closer, guide arm, bolts and aluminium drilling template.

Replacement time only 20 minutes thanks to the already threaded fixing holes on the door closer, and assembly with 6 pass-through holes in the aluminium template of the accessory set.

10 mm thick template with sleeve to fit into the shaft hole of the old door closer already in the door.

Then the 2 holes for adjusting screws must be countersunk and the new guide is fixed and a notch is made in the upper edge of the door to pass the arm to the shaft side.

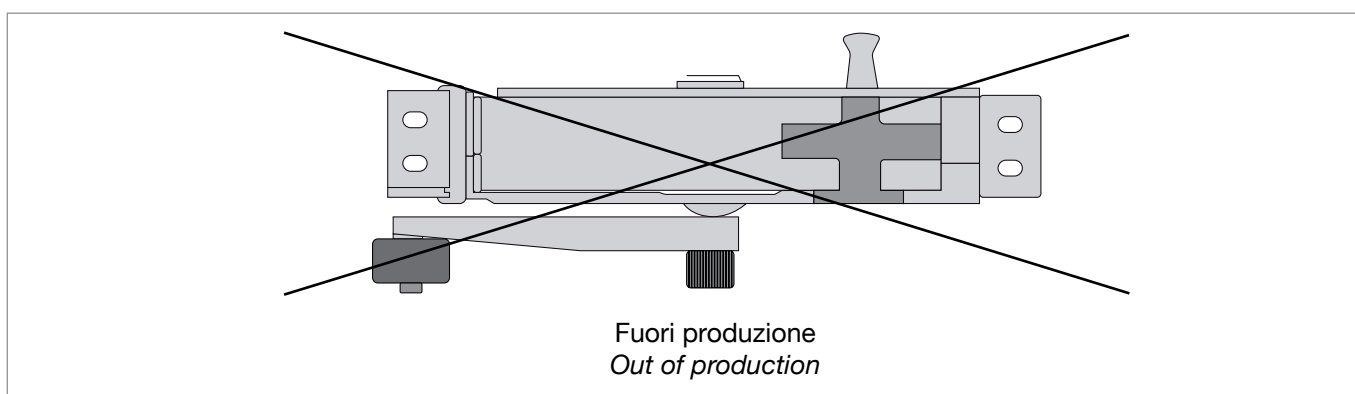
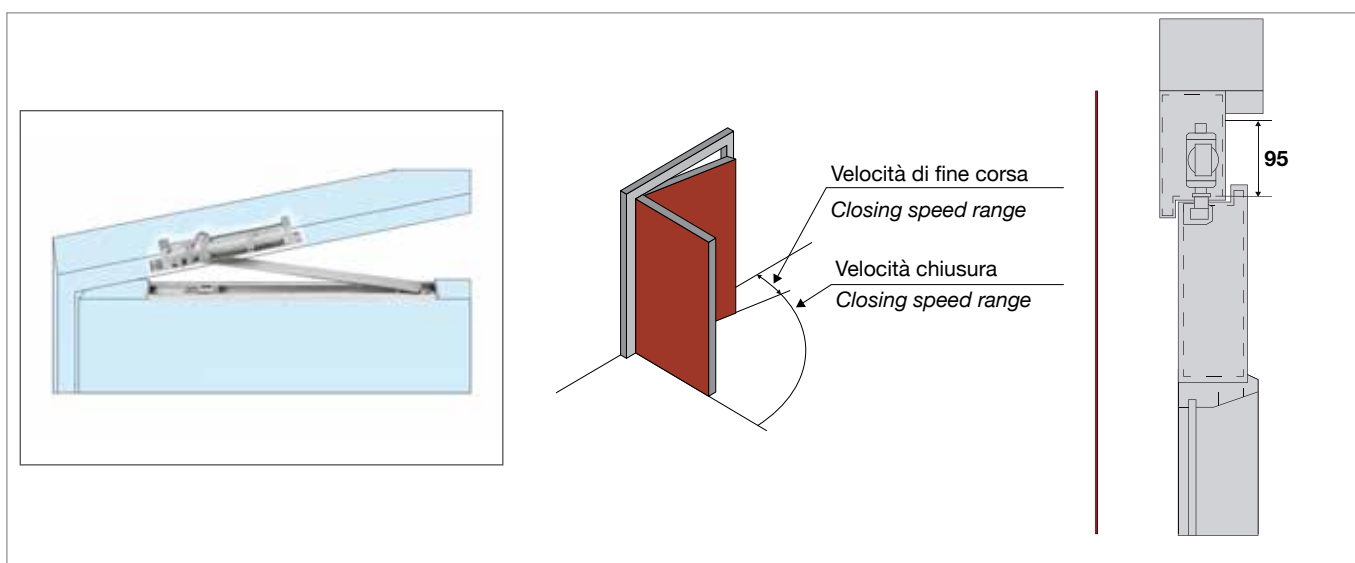

Codice / Code	Descrizione / Description
205124IR	Chiudiporta Ds Ryobi CO52 con braccio guida bulloneria dima in alluminio istruzioni di montaggio

CHIUDIPIORTA DICTATOR LS FZ I PER SOSTITUZIONE FIAM FUORI PRODUZIONE

DICTATOR DOOR CLOSER LS FZ I FOR REPLACEMENT FIAM OUT OF PRODUCTION



Il chiudiporta Dictator LS FZ I serve per la sostituzione del chiudiporta FIAM ormai irreperibile, viene fornito con chiare istruzioni per la sostituzione, ed è composto da: chiudiporta , piastre filettate, braccio con vite, guida, dima e bulloneria.

The Dictator LS FZ door closer, used for replacement FIAM door closer, now unavailable. It's provided with clear instruction for replacement, it's assembled by: door closer, threaded plate, arm with screw, guide, template and bolt.

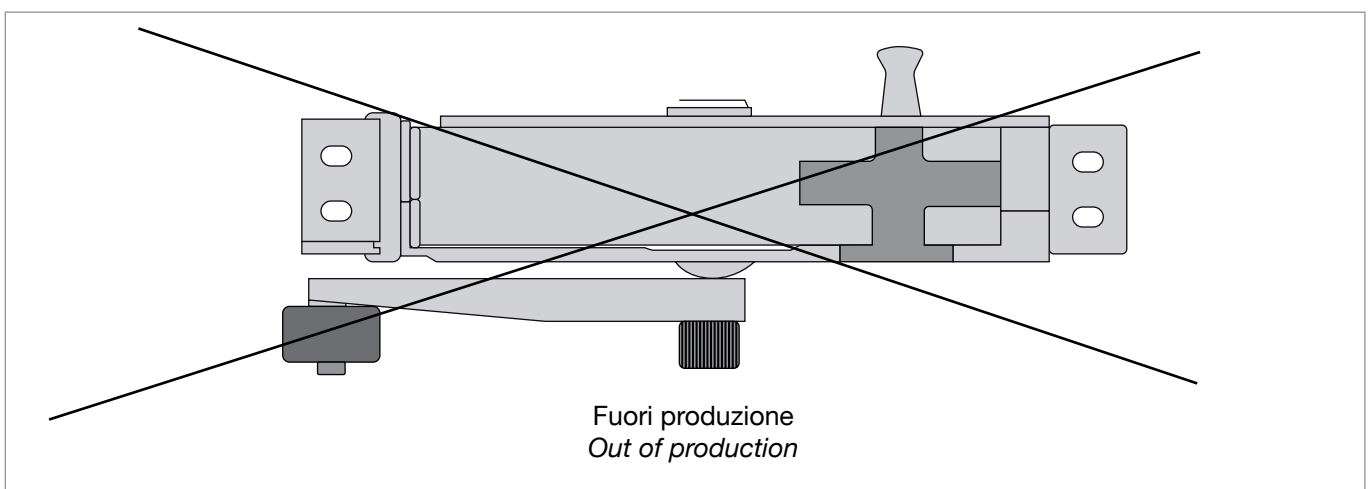
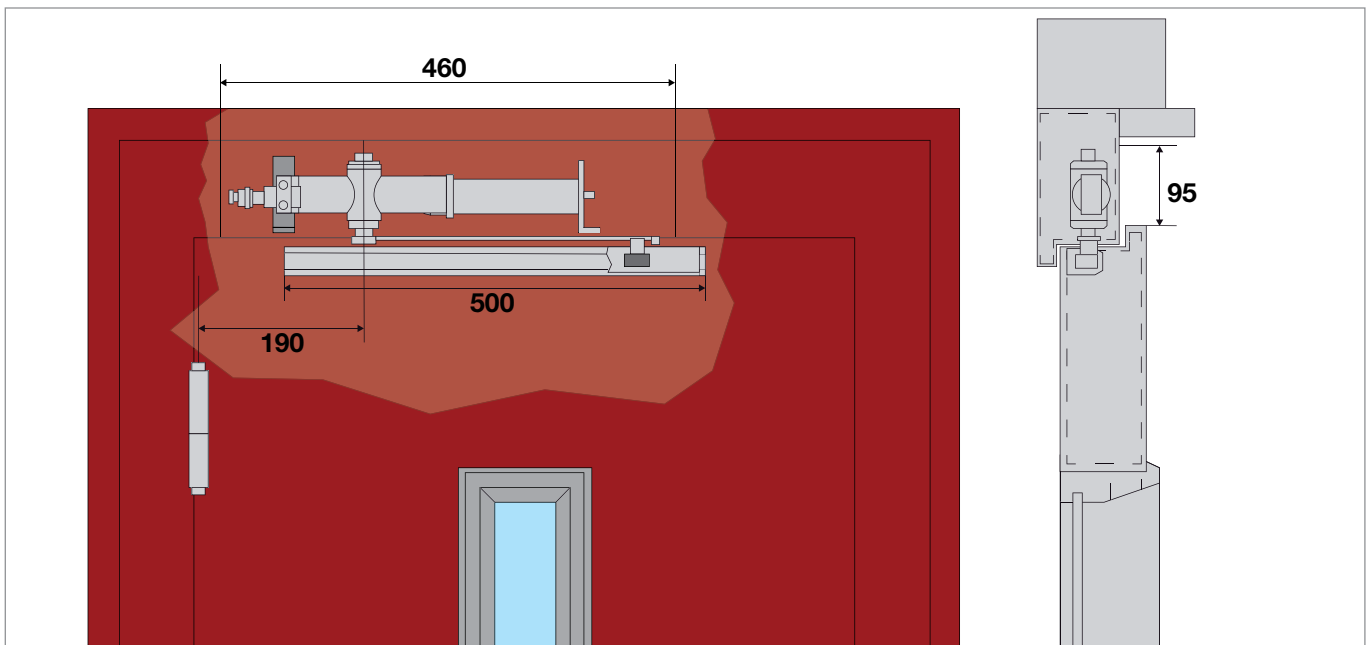

Codice / Code	
205121I	Chiudiporta Dictator LS FZ I tipo ROSSO per applicazione interna
205124I	Chiudiporta Dictator LS FZ I tipo BLU per applicazione interna

CHIUDIPIORTA DICTATOR LX OTIS NUOVA ESECUZIONE DICTATOR DOOR CLOSER LX OTIS NEW EXECUTION

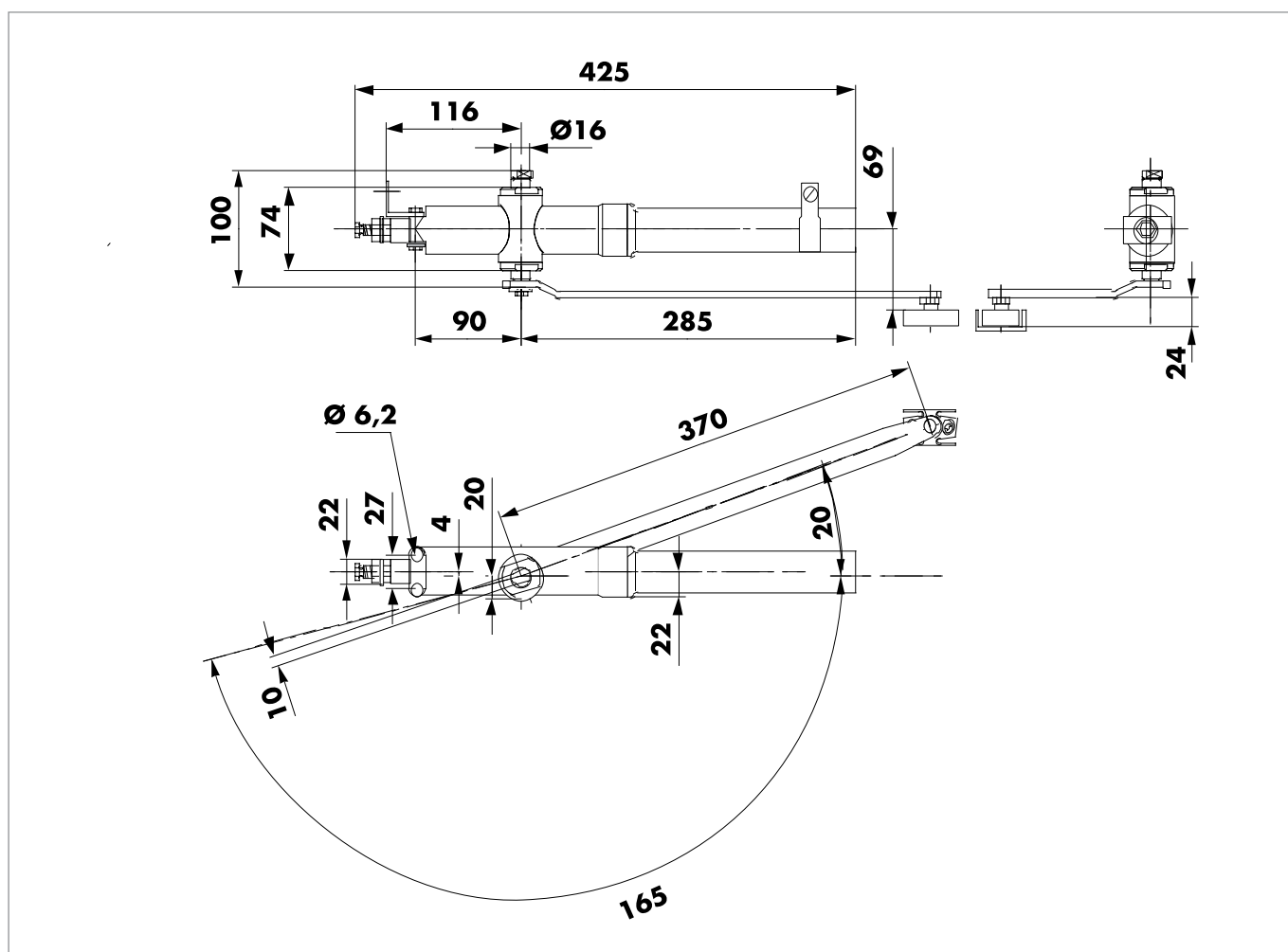
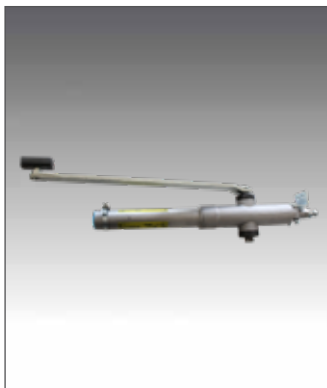

Codice / Code	Tipo/Type	Descrizione
600008	Porta pesante	Chiudiporta Dictator LX OTIS completo di braccio e staffe di fissaggio
600014X	Porta standard	Chiudiporta Dictator LX OTIS completo di braccio e staffe di fissaggio

CHIUDIPIORTA OTIS NUOVA ESECUZIONE PER SOSTITUZIONE CHIUDIPIORTA OTIS A LEVA VECCHIA ESECUZIONE DOOR CLOSER OTIS NEW EXECUTION FOR REPLACEMENT OTIS DOOR CLOSER WITH LEVER OLD EXECUTION

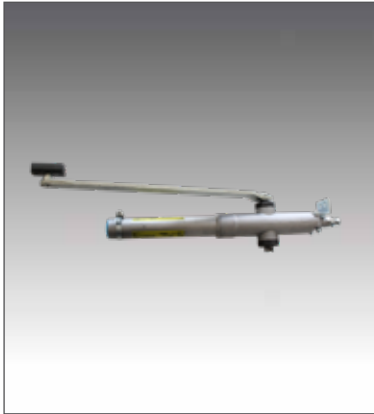

INSTALLAZIONE CHIUDIPIORTA DICTATOR LX OTIS

INSTALLATION DICTATOR LX OTIS DOOR CLOSER

- A.** Fare con una fresa a tazza un foro \varnothing 20 mm per fare passare nella lamiera interna dentro alla porta il perno del chiudiporta Cod. 600014X a interasse 115 mm dal piano verticale di fissaggio dell'attacco del chiudiporta.
- B.** Montare l'attacco posteriore
- C.** Smollare la squadretta anteriore infilare la fascetta in 2 fori \varnothing 8 mm. fatti in opera quindi stringere in tutto

A. To make a \varnothing 20 mm hole with hole cutter to pass internal metal sheet inside the door pivot CODE.600014X, inter axle 115 mm from vertical surface of the mounting plate of door closer.

B. To mount the back mounting plate

C. To loosen front bracket, inserting clamp in 2 holes \varnothing 8 done on site, then tighten completely.

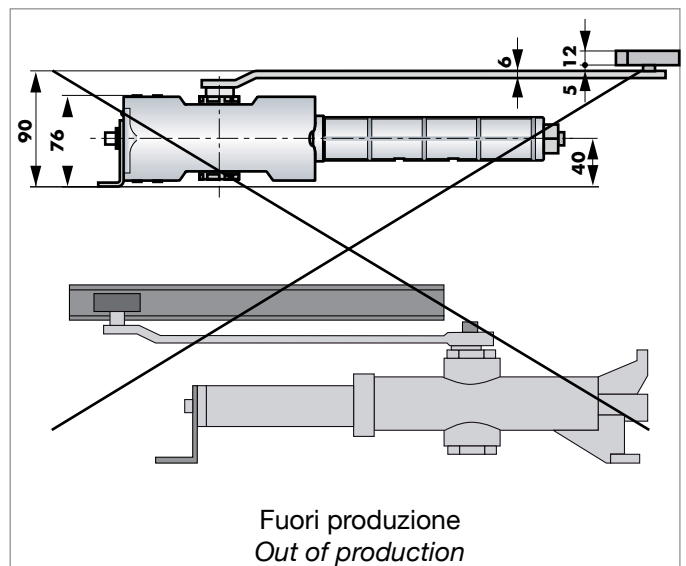
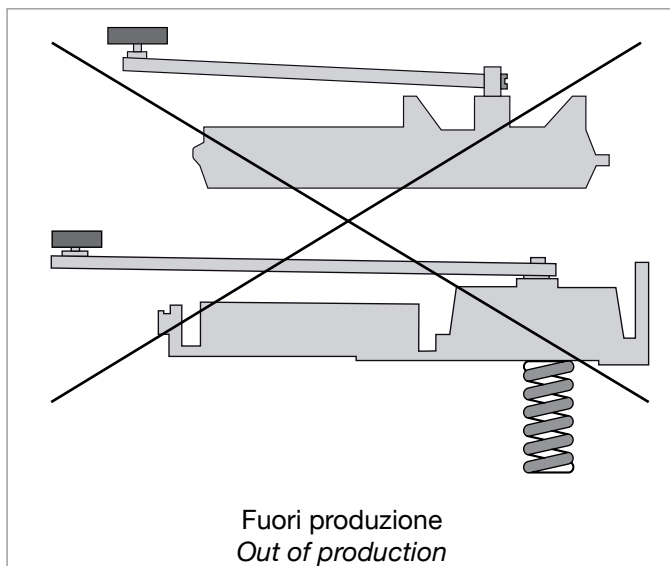
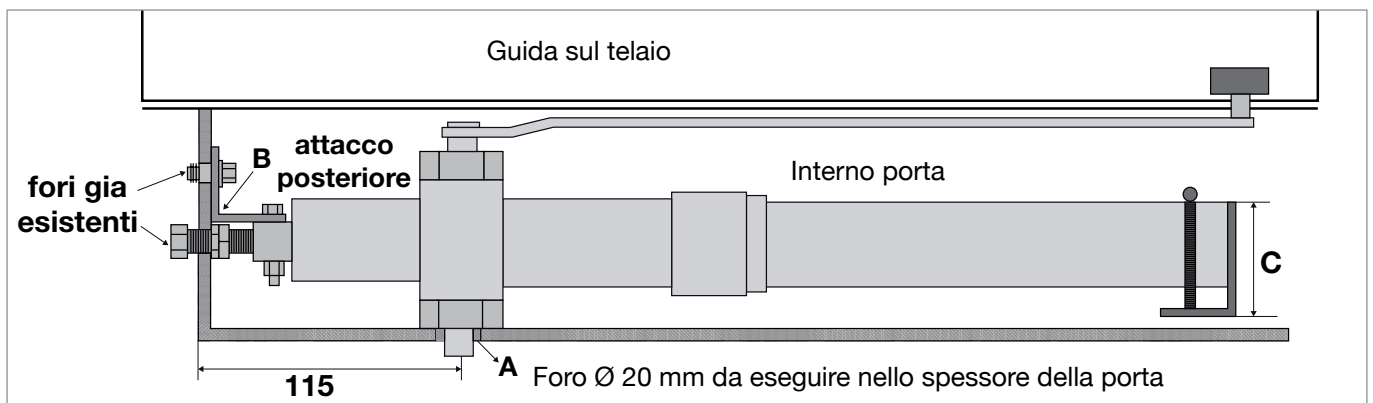

CHIUDIPIORTA RYOBI CO 52 - CO 53 - CO 54 RYOBI CO 52 - CO 53 - CO 54 DOOR CLOSER



CO 52 - CO 53 - CO 54

I·S_{top}
N·O·S_{top}
↻ 2 speed
2VA
500,000 cycles
R and L



- Qualità ed economia
 - Due regolazioni di velocità di chiusura separate dalla velocità di finecorsa
 - Decelerazione idraulica regolabile in apertura contro gli urti meccanici
 - Angolo di apertura regolabile con arresto elastico
 - Fermoporta regolabile
 - Forza di chiusura 2, 3 e 4
 - Garantito minimo 500.000 cicli di funzionamento
 - Montaggio nella porta o nell'architrave del telaio
 - Ambidestro
- *Quality and economy*
 - *Two closing speed adjustment are separated from latching speed range*
 - *Hydraulic deceleration adjustment for opening against mechanical shocks*
 - *The opening angle adjustment with elastic stop*
 - *Adjustable door stop*
 - *Closing force 2, 3 and 4*
 - *Guaranteed minimum 500,000 operating cycles*
 - *Mounting in the door or in lintel of the frame*
 - *Ambidextrous*

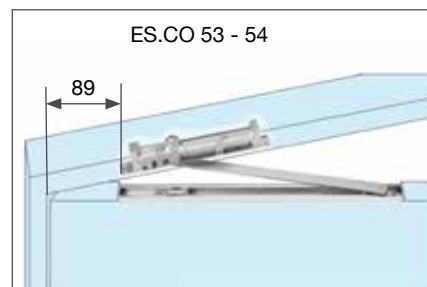
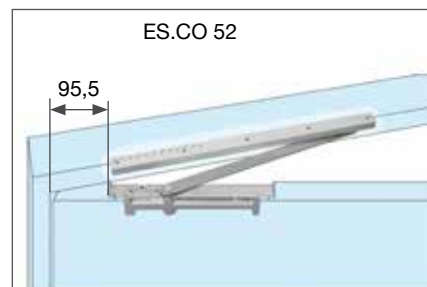

Codice / Code		Dimensioni porta (mm) Door dimension (mm)	Peso anta (Kg) door weight (kg)	Spessore / thickness				Spessore chiudiporta doorcloser thickness
				Porte metalliche Metallic door		Porte in legno Wooden door		
Senza fermo Without stop	Con fermo With stop			Nella porta In door	Nel telaio In frame	Nella porta In door	Nel telaio In frame	
CO 52	CO 152	900 x 2100	45	≥ 40 mm	≥ 38 mm	≥ 45 mm	≥ 43 mm	31 mm
CO 53	CO 153	950 x 2100	65	≥ 45 mm	≥ 38 mm	≥ 50 mm	≥ 43 mm	36 mm
CO 54	CO 154	1050 x 2400	85					

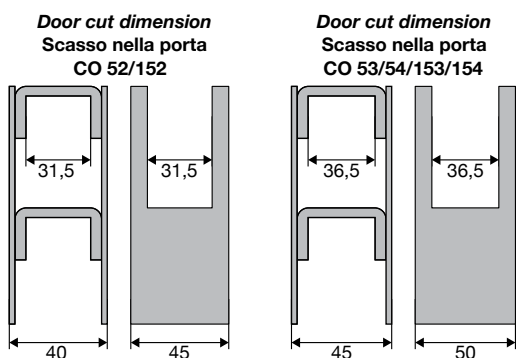

*Raffigurata porta lato tirare destra le dimensioni di installazione sono analoghe per porta tirare sinistra

*To present the dimension of installation for door pull right side is similar for door pull left side

CHIUDIPIORTA RYOBI CO 52 - CO 53 - CO 54

RYOBI CO 52 - CO 53 - CO 54 DOOR CLOSER

RYOBI CO 52

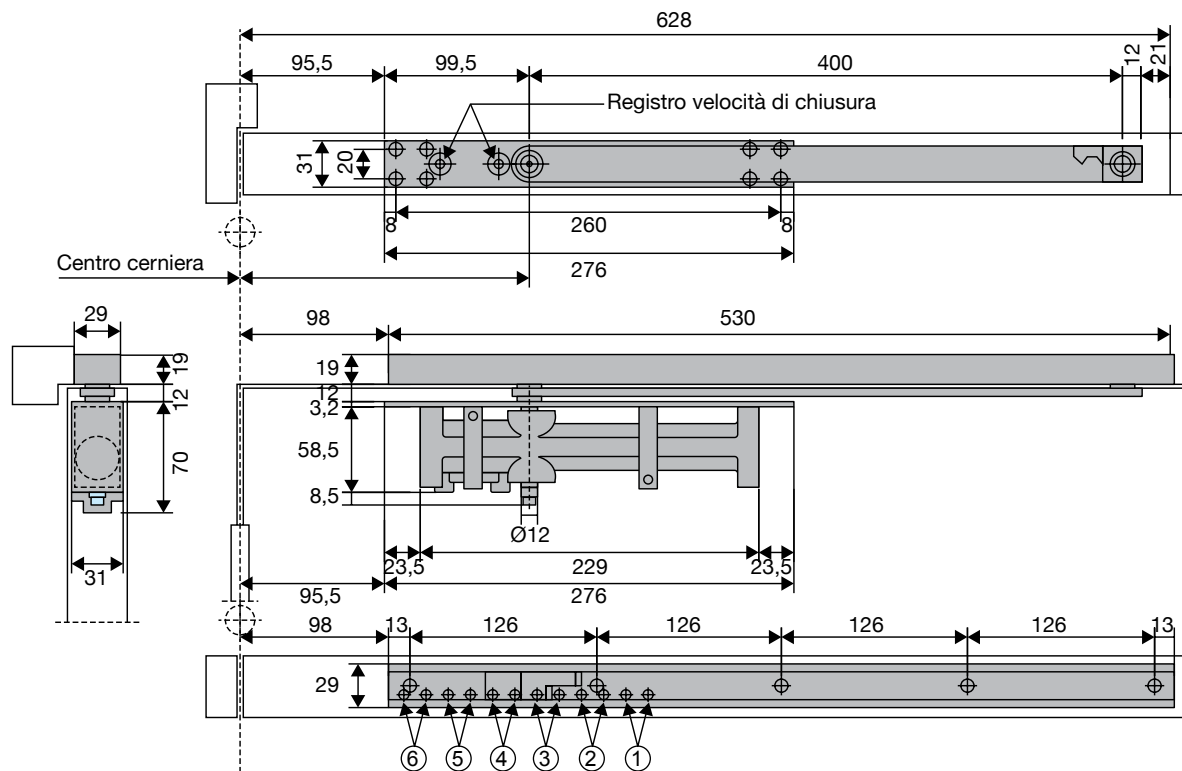

Posizione installazione per angolo di apertura con e senza fermo con decelerazione meccanica e apertura fino a 180°

Installation position for opening angle with or without stop with mechanical deceleration and opening up to 180°

ANGOLO DI APERTURA

①	②	③	④	⑤	⑥
100°	109°	119°	133°	155°	180°

RYOBI CO 53/54

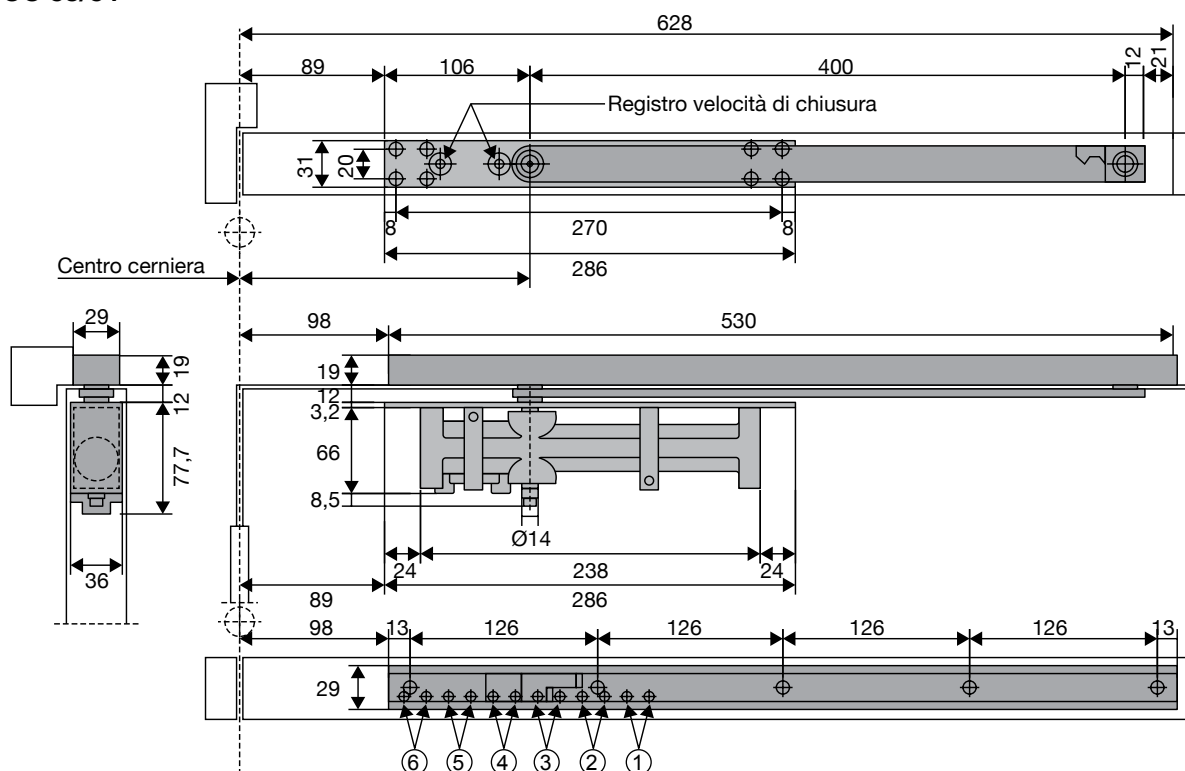

CHIUDIPIORTA THIESS THIESS DOOR CLOSER

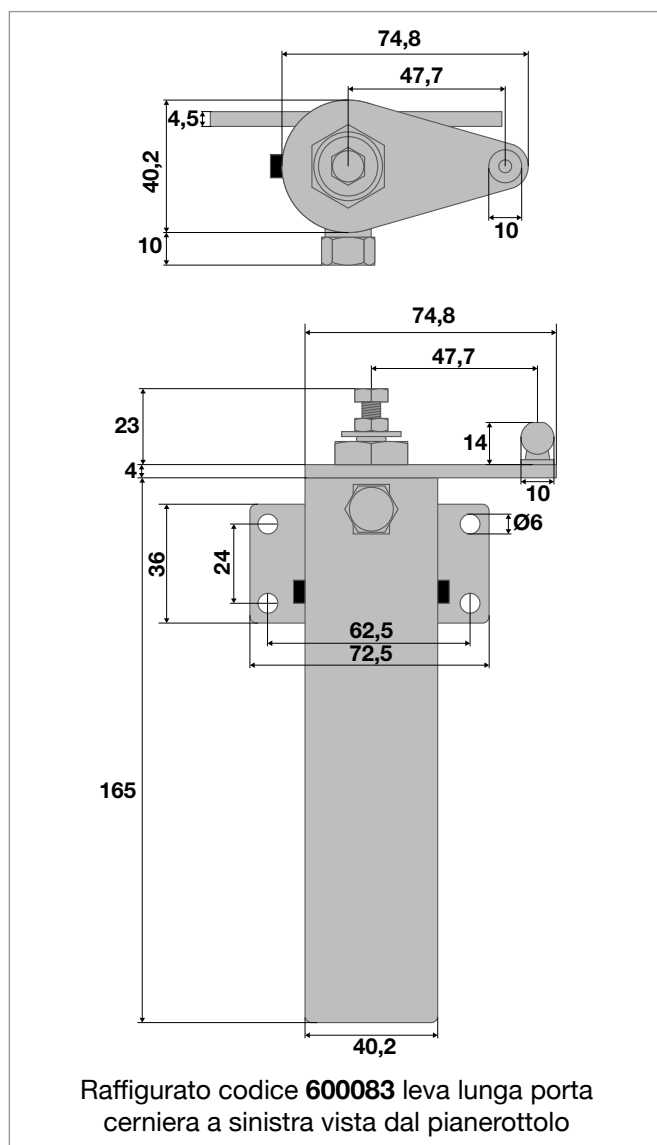
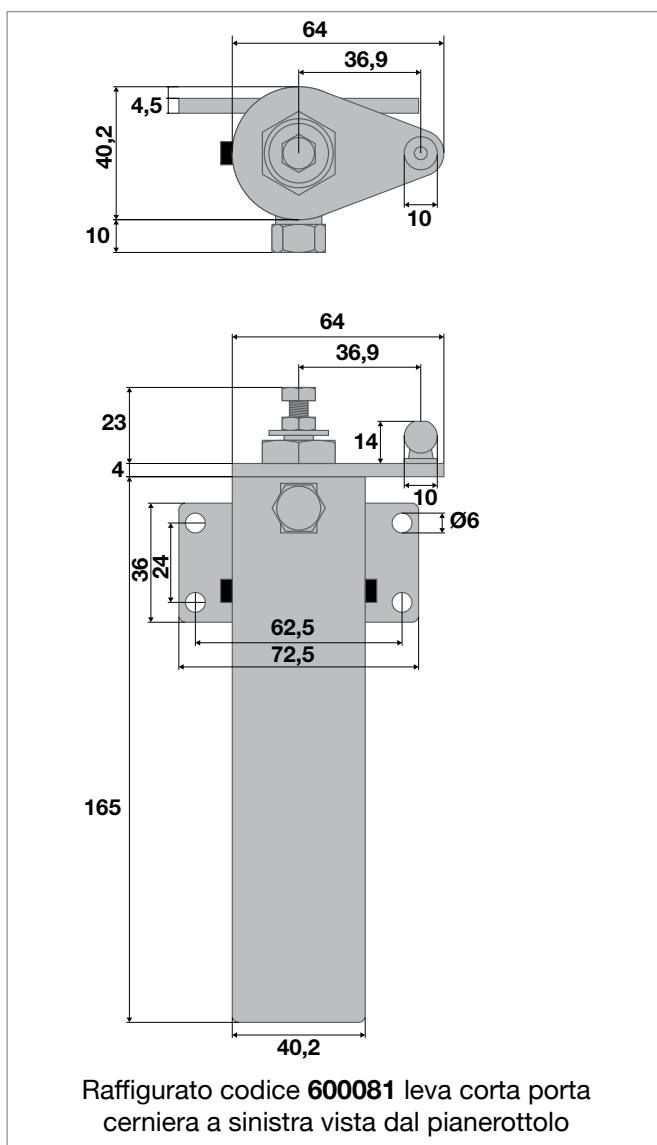
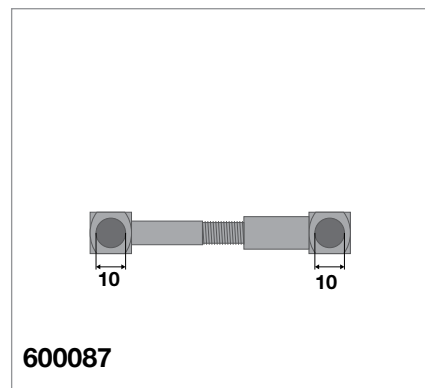
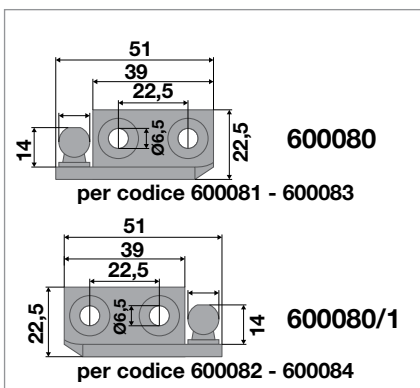

Codice	Descrizione	Codice	Descrizione Accessori
600081	Thies leva corta porta cerniera a sinistra*	600080	Squadretta per Thies porta cerniera a destra*
600082	Thies leva corta porta cerniera a destra*	600080/1	Squadretta per Thies porta cerniera a sinistra*
600083	Thies leva lunga porta cerniera a sinistra*	600087	Tirante (braccio) per Thies
600084	Thies leva lunga porta cerniera a destra*		

* vista dal vano corsa

SOSTITUZIONE CHIUDIPIORTA SABIEM CON ACCESSORI DICTATOR PORTA A BATTENTE

SABIEM DOOR CLOSER REPLACEMENT WITH DICTATOR ACCESSORIES SWING DOOR

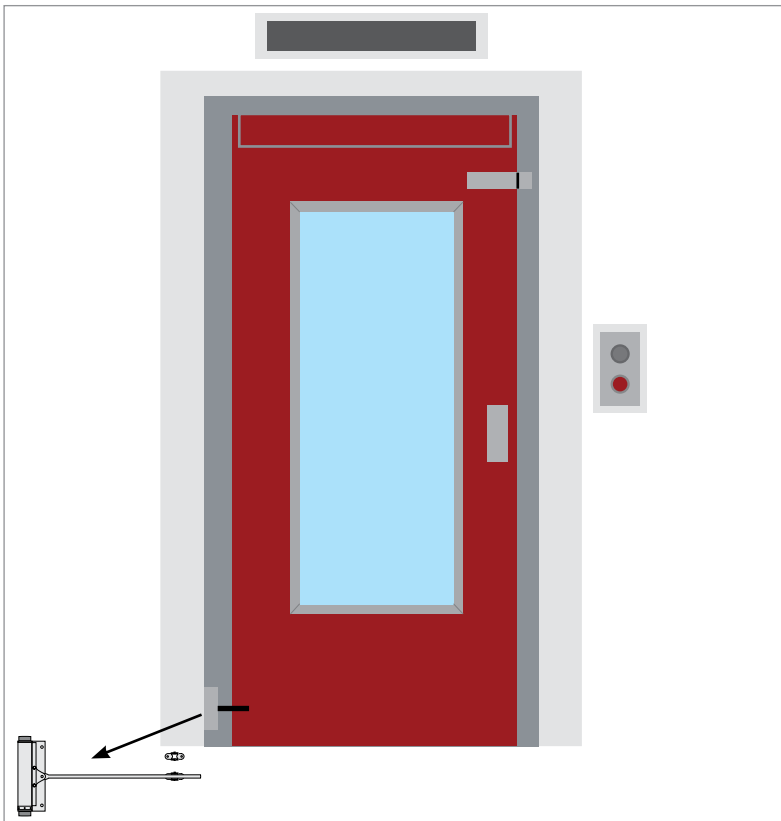
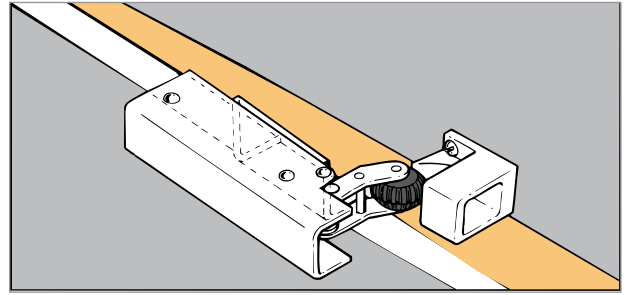

300300

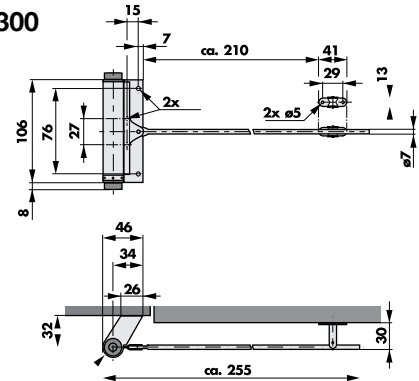

300575X

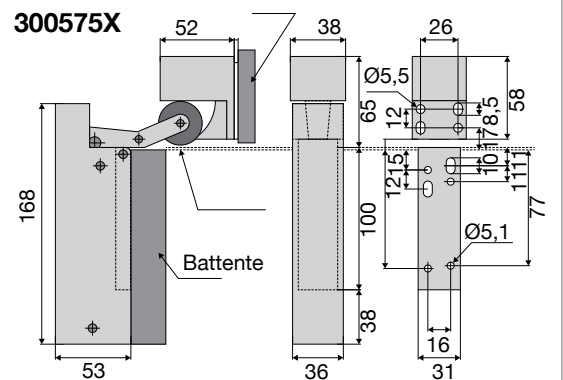

1. Lasciare il vecchio chiudiporta con solo funzione di perno della porta levando la molla e l'olio.
2. Montare il chiudiporta Dictator Universal VS 2000 da 20N.
3. Montare la molla Dictator D2A regolando la velocità di chiusura al minimo ma accertandosi che chiude anche se la porta viene aperta di soli 20 gradi.
4. Regolare la decelerazione del chiudiporta Dictator Universal VS 2000.

1. To leave old door closer with functional pivot only of the door removing the spring and the oil.
2. To mount the door closer Dictator UNIVERSAL VS 2000 20N.
3. To mount the dictator spring D2A, regulating speed in minimum, however to ensure that door can be closed if the door is opened only in 20 degrees.
4. Regulating the deceleration of door closer Dictator Universal VS 2000.

Chiudiporta SABIEM fuori produzione
SABIEM door close out of production



Codice	Fornitura	Descrizione	Forza
300575X	Cromato opaco (Argento)	Chiudiporta DICTATOR VS 2000	20 N
300300	Nichelato	Chiudiporta a molla D2A	10 N

MONTAGGIO AMMORTIZZATORE DICTATOR NEL CHIUDIPIORTA SCHLIEREN SD 58

MOUNTING DICTATOR DAMPER INSIDE SCHLIEREN SD 58 DOOR CLOSER

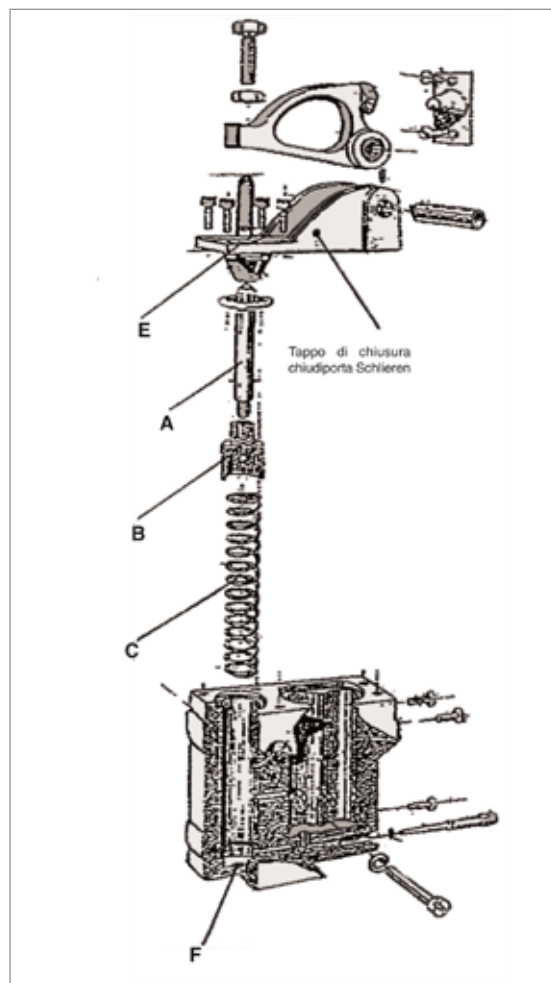

1. Smontare il chiudiporta SCHLIEREN levare i particolari **A-B-C** e l'olio idraulico che non verranno più utilizzati.
2. Inserire l'ammortizzatore nel tappo di chiusura del chiudiporta SCHLIEREN fermandolo con il seeger fornitovi.
3. Posizionare la rondella sp 2 mm nel fondo del chiudiporta richiudendo il tappo di chiusura rimontando la sua leva.

1. Take apart the door closer SCHLIEREN ,remove the parts **A-B-C**, and hydraulic oil that will no longer be used.
2. Insert damper on the closing cap of SCHLIEREN door closer, stopping it with seeger provided
3. To place the washer 2mm thickness on the bottom of the door closer, closing the closing cap then reassemble its lever.

Codice	Descrizione
203402A	Ammortizzatore Dictator SCHLIEREN cromato opaco (argento)

CHIUDIPIORTA AUGUSTO STIGLER SPECIFICO ED INTERCAMBIABILE SU ASCENSORI AUGUSTO STIGLER SEMIAUTOMATICO AUGUSTO STIGLER DOOR CLOSER SPECIFIC AND INTERCHANGEABLE ON SEMI AUTOMATICS AUGUSTO STIGLER LIFT



Chiudiporta Augusto STIGLER specifico ed intercambiabile su ascensori Augusto STIGLER semiautomatico.

Augusto STIGLER door closer specific and interchangeable on semi automatics Augusto STIGLER lift.

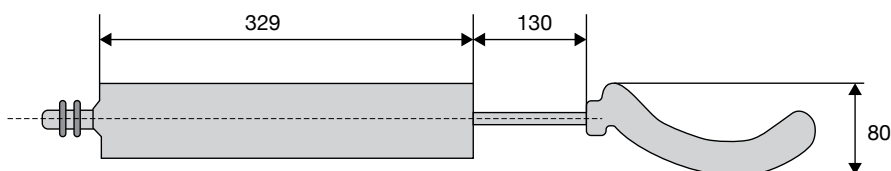

600045

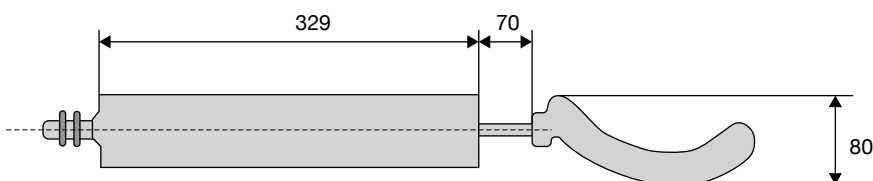

600046

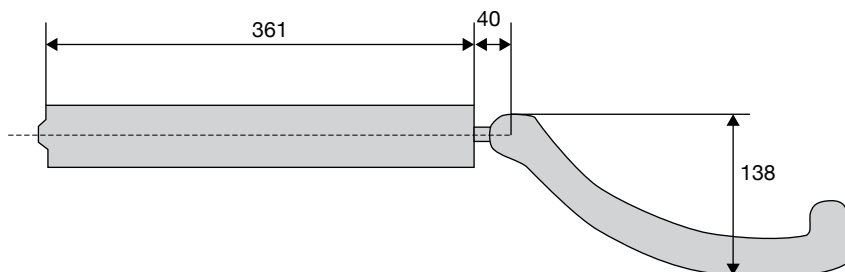

600047

Codice	Descrizione
600045	Chiudiporta A. STIGLER semiautomatico - 130
600046	Chiudiporta A. STIGLER semiautomatico - 70
600047	Chiudiporta A. STIGLER semiautomatico - 40

CHIUDIPIORTA DICTATOR TIPO FALCONI DICTATOR DOOR CLOSER TYPE FALCONI



Chiudiporta con molla meccanica separata solo ammortizzante regolabile per porte a battente FALCONI

Door closer with separate mechanical spring is the only regulated damper for FALCONI hinged door.

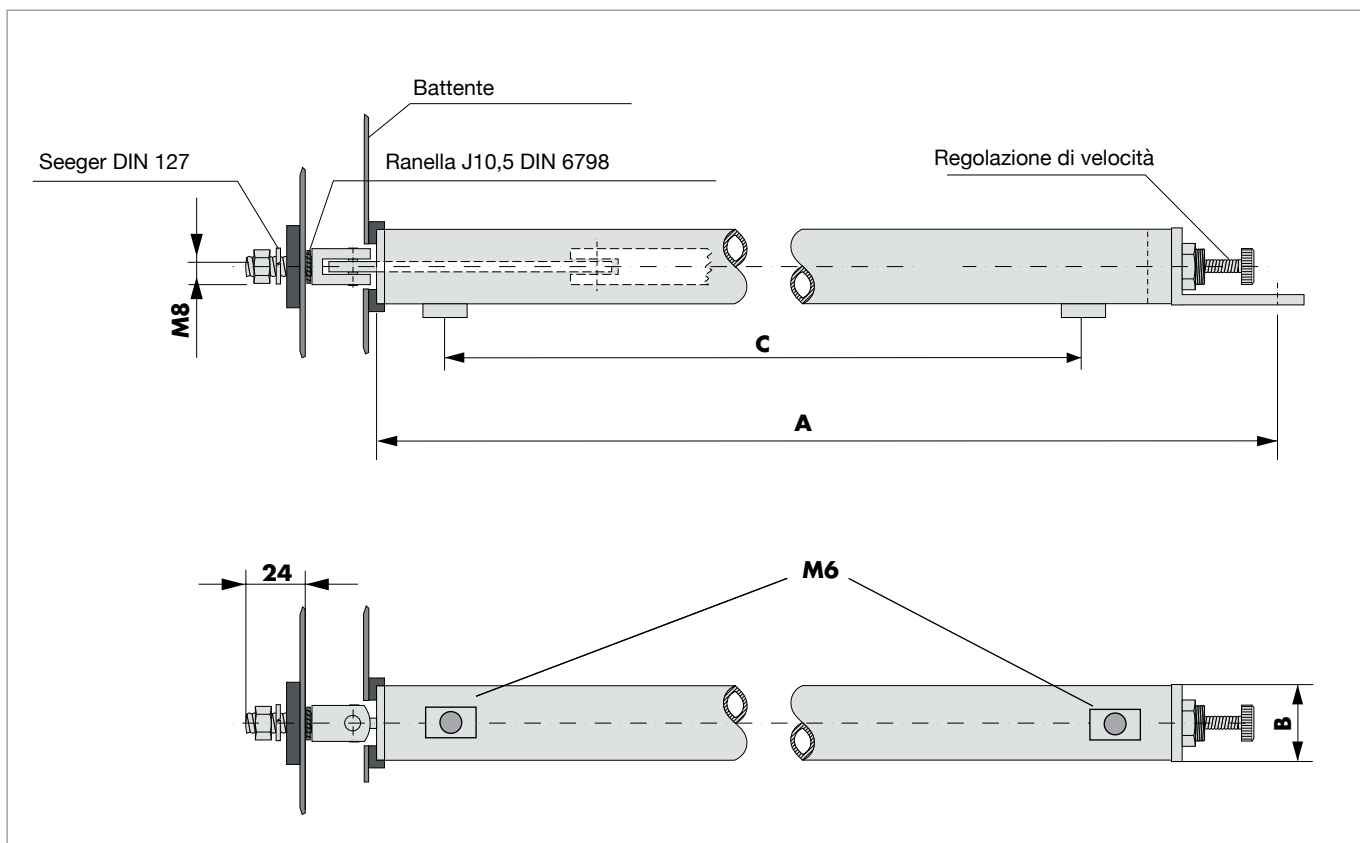

A	B	C
460 mm	35 mm	410 mm

Codice	Descrizione
203089	Chiudiporta Dictator tipo FALCONI senza molla solo ammortizzante <i>Door closer type FALCONI Without spring version only damper</i>

CHIUDIPIORTA TUBOLARE DICTATOR ATS "A", "AK", "MAN", "KL" CON PIASTRA FRONTALE DI MONTAGGIO" DICTATOR ATS "A", "AK", "MAN", "KL" TUBULAR DOOR CLOSER WITH FRONTAL MOUNTING PLATE FOR LIFT DOORS

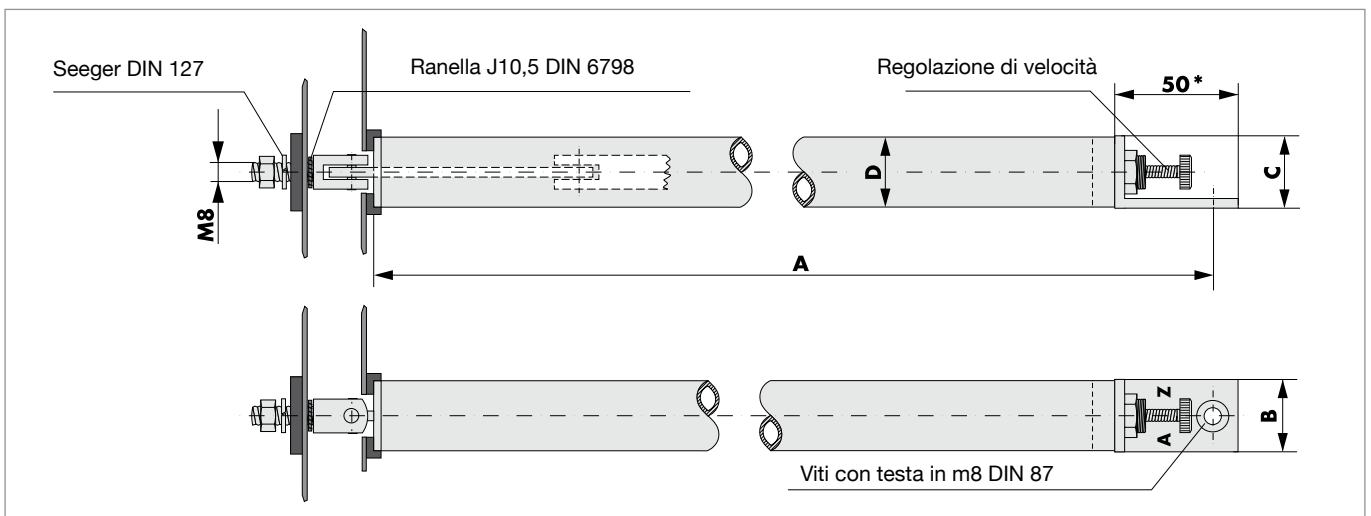
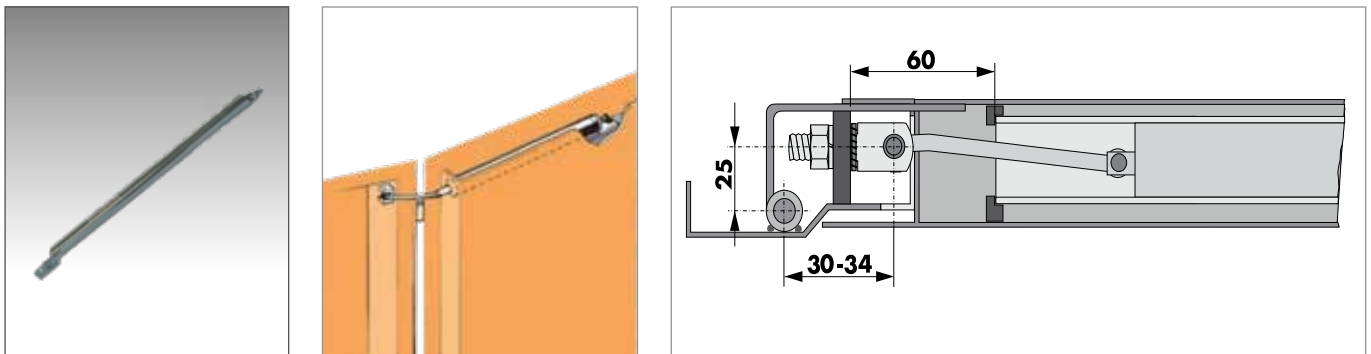

Descrizione - Description	ATS 400 A	ATS 400 AK	ATS 400 KL	ATS 800 A	ATS 800 A
Misura "A" in mm - Length "A" in mm	500	420	320	550	551
Diametro tubo in mm - Cylinder diameter in mm	Ø34	Ø34	Ø34	Ø34	Ø34
Piastra frontale misura "B" in mm - Front plate "B" in mm	34/34	34/34	34/34	34/34	34/34
Piastra posteriore misure "C" in mm - Rear plate "C" in mm	47	49	47	49	
Forza chiusura a 0° (N) - Closing force 0° (N)	12	12	12	18	18
Forza apertura 0° - 90° (N) - Opening force 0° - 90° (N)	20-30	20-30	20-30	30-40	30-40
Velocità 90° - 0° (sec) - Speed 90° - 0° (sec)	3-4	3-4	3-4	3-4	3-4
Angolo d'apertura max - Max. Opening angle	110°	110°	110°	110°	110°

Codice - Code	Tipo - Type
400010	ATS 400 A
400011	ATS 400 AK
400012	ATS 800 A
400013	ATS 400/35 MAN
400014	ATS 400 KL

CHIUDIPIORTA TUBOLARE DICTATOR ATS "A" CON PIASTRA FRONTALE DI MONTAGGIO

DICTATOR ATS "A" TUBULAR DOOR CLOSER WITH FRONTAL MOUNTING PLATE FOR LIFT DOORS

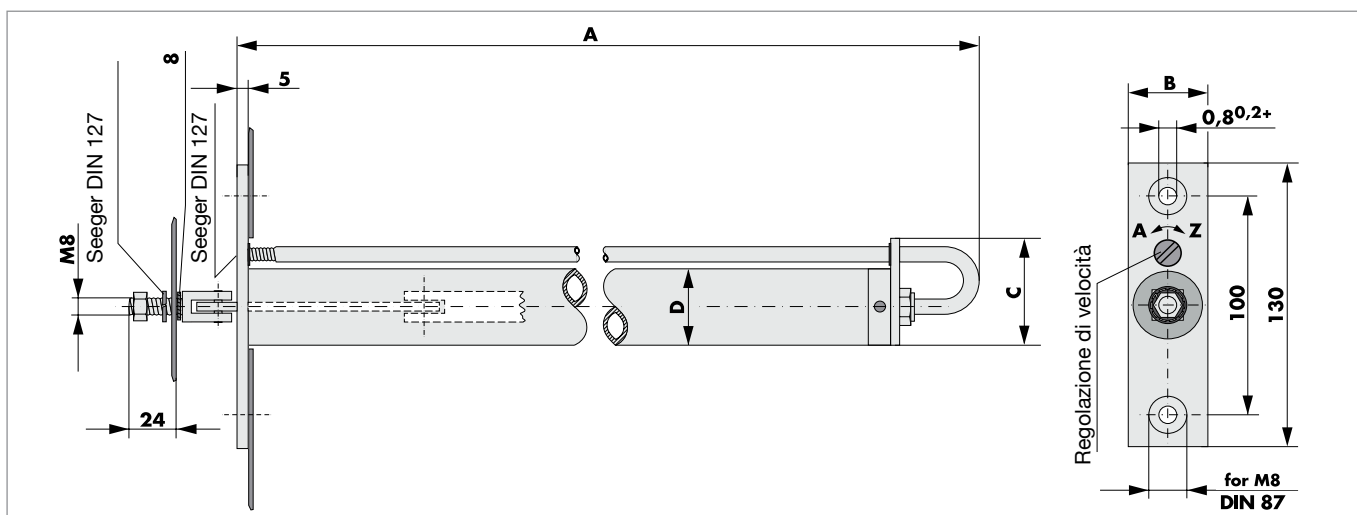
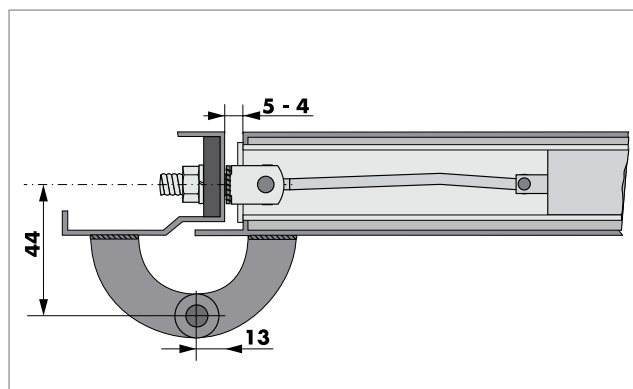

Descrizione - Description	ATS 500/30 A	ATS 500/35 A	ATS 600/30 A	ATS 600/35 A
Misura "A" in mm - Length "A" in mm	500	500	550	550
Diametro tubo in mm - Cylinder diameter in mm	Ø29	Ø34	Ø29	Ø34
Piastra frontale misura "B" in mm - Front plate "B" in mm	30	35	30	35
Piastra posteriore misure "C" in mm - Rear plate "C" in mm	47	49	47	49
Forza apertura a 0° (N) - Closing force 0° (N)	12	12	18	18
Forza chiusura 0° - 90° (N) - Opening force 0° - 90° (N)	20-30	20-30	30-40	30-40
Velocità 90° - 0° (sec) - Speed 90° - 0° (sec)	3-4	3-4	3-4	3-4
Angolo d'apertura max - Max. Opening angle	165°	165°	165°	165°

Codice - Code	Tipo - Type
400200	ATS 500/30 A
400203	ATS 500/35 A
400220	ATS 600/30 A
400223	ATS 600/35 A

CHIUDIPIORTA TUBOLARE DICTATOR ATS-O,A CON PIASTRA FRONTALE DI MONTAGGIO

DICTATOR ATS-O,A TUBULAR DOOR CLOSER WITH FRONTAL MOUNTING PLATE FOR LIFT DOORS

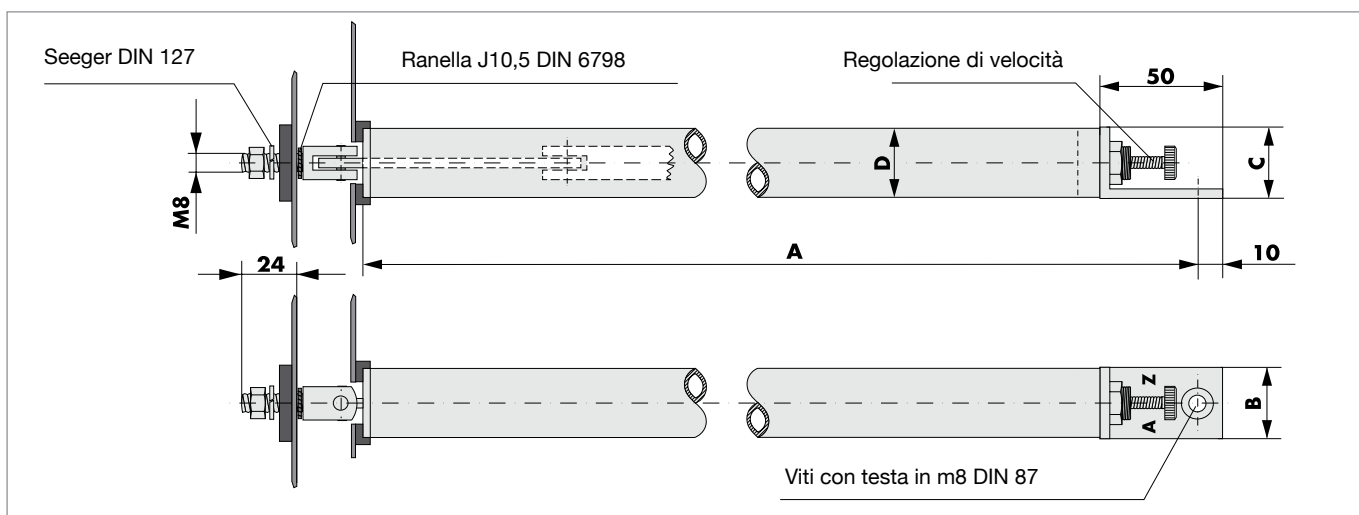
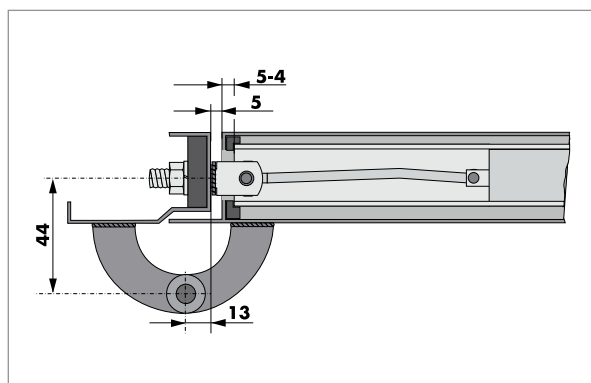

Descrizione - Description	ATS 500 O,A	ATS 500/35 O,A	ATS 600/30 O,A	ATS 600/35 O,A
Misura "A" in mm - Length "A" in mm	500	500	551	551
Diametro tubo in mm - Cylinder diameter in mm	Ø29	Ø34	Ø29	Ø34
Piastra frontale misura "B" in mm - Front plate "B" in mm	30/30	35/35	30/30	35/35
Piastra posteriore misure "C" in mm - Rear plate "C" in mm	47	49	47	49
Forza apertura a 0° (N) - Closing force 0° (N)	12	12	20	20
Forza chiusura 0° - 90° (N) - Opening force 0° - 90° (N)	20-30	20-30	30-40	30-40
Velocità 90° - 0° (sec) - Speed 90° - 0° (sec)	3-4	3-4	3-4	3-4
Angolo d'apertura max - Max. Opening angle	165°	165°	165°	165°

Codice - Code	Tipo - Type
400199	ATS 500/30 O,A
400204	ATS 500/35 O,A
400224	ATS 600/35 O,A
400238	ATS 600/30 O,A

CHIUDIPIORTA TUBOLARE DICTATOR ATS-K,A CON PIASTRA FRONTALE DI MONTAGGIO

DICTATOR ATS-K,A TUBULAR DOOR CLOSER WITH FRONTAL MOUNTING PLATE FOR LIFT DOORS

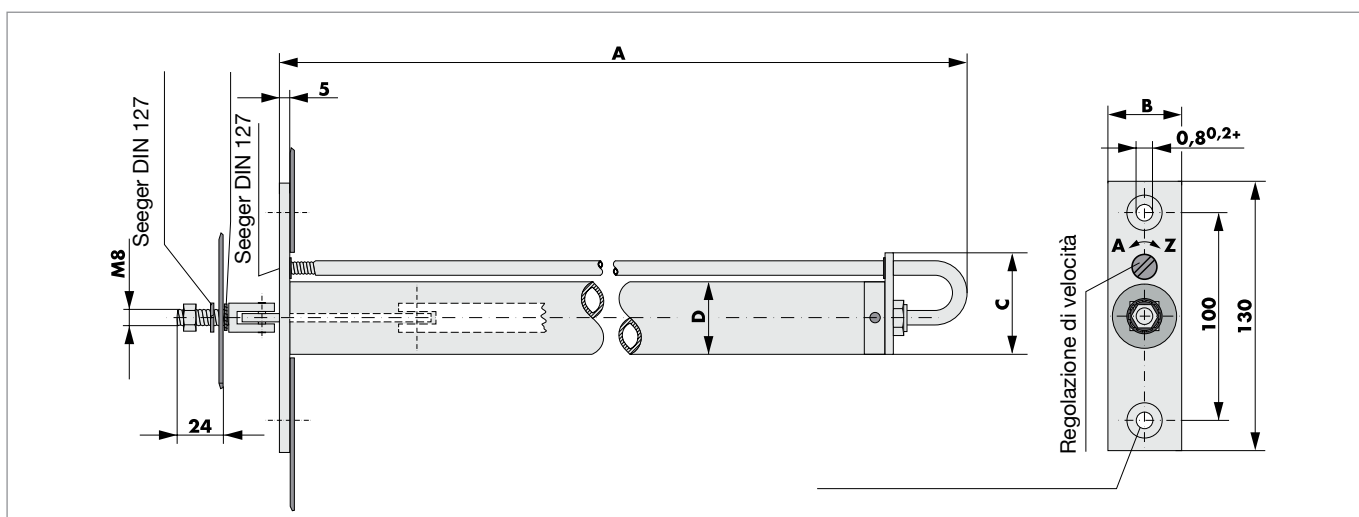
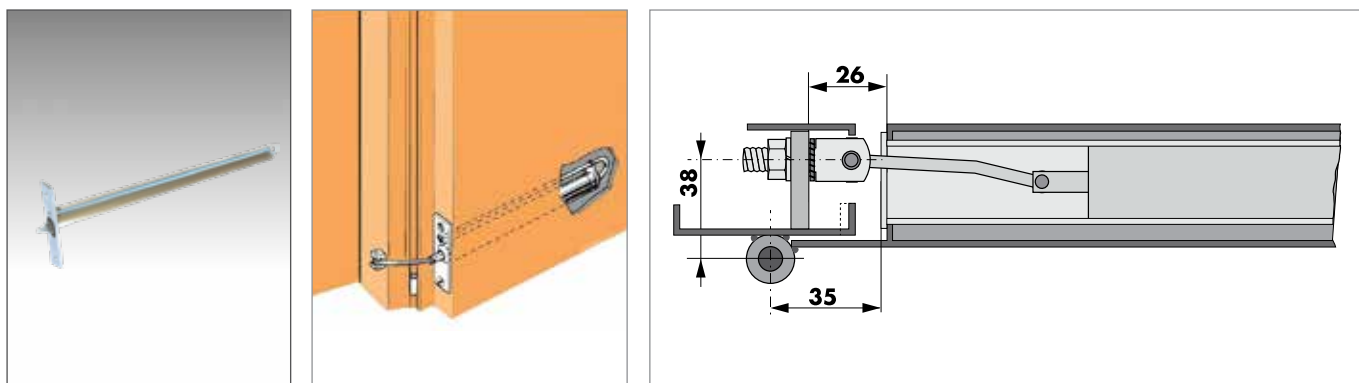

Descrizione - Description	ATS 500/30 K,A	ATS 500/35 K,A	ATS 600/30 K,A	ATS 600/35 K,A
Misura "A" in mm - Length "A" in mm	500	500	550	550
Diametro tubo in mm - Cylinder diameter in mm	Ø29	Ø84	Ø29	Ø84
Piastra frontale misura "B" in mm - Front plate "B" in mm	30	35	30	35
Piastra posteriore misure "C" in mm - Rear plate "C" in mm	47	49	47	49
Forza apertura a 0° (N) - Closing force 0° (N)	12	12	20	20
Forza chiusura 0° - 90° (N) - Opening force 0° - 90° (N)	20-30	20-30	30-40	30-40
Velocità 90° - 0° (sec) - Speed 90° - 0° (sec)	3-4	3-4	3-4	3-4
Angolo d'apertura max - Max. Opening angle	120°	120°	120°	120°

Codice - Code	Tipo - Type
400201	ATS 500/30 K,A
400205	ATS 500/35 K,A
400221	ATS 600/30 K,A
400225	ATS 600/35 K,A

CHIUDIPIORTA TUBOLARE DICTATOR ATS-KO,A CON PIASTRA FRONTALE DI MONTAGGIO

DICTATOR ATS-KO,A TUBULAR DOOR CLOSER WITH FRONTAL MOUNTING PLATE FOR LIFT DOORS

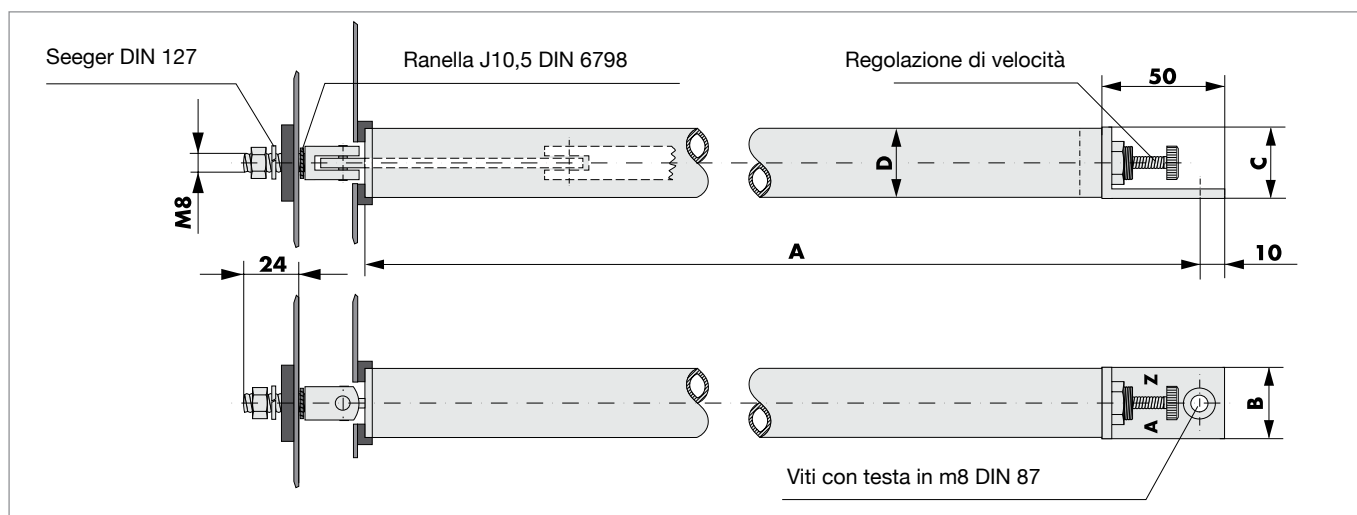
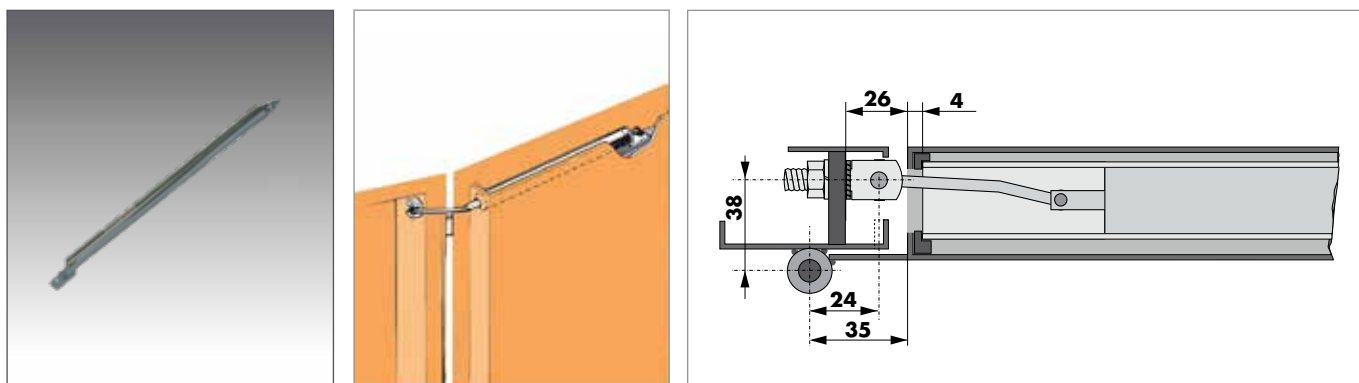

Descrizione - Description	ATS 500/30 KO,A	ATS 500/35 KO,A	ATS 600/30 KO,A	ATS 600/35 KO,A
Misura "A" in mm - Length "A" in mm	500	500	551	550
Diametro tubo in mm - Cylinder diameter in mm	Ø29	Ø34	Ø29	Ø34
Piastra frontale misura "B" in mm - Bracket "B/C" in mm	30/30	35/35	30/30	35/35
Forza apertura a 0° (N) - Closing force 0° (N)	12	12	20	20
forza chiusura 0° - 90° (N) - Opening force 0° - 90° (N)	20-30	20-30	30-40	30-40
Velocità 90° - 0° (sec) - Closing time 90° - 0° (sec)	3-4	3-4	3-4	3-4
Angolo d'apertura max - Max. Opening angle	120°	120°	120°	120°

Codice - Code	Tipo - Type
400202	ATS 500/30 KO, A
400206	ATS 500/35 KO, A
400222	ATS 600/30 KO, A
400226	ATS 600/35 KO, A

CHIUDIPIORTA RYOBI COU SE EXTRAPIATTO (30mm) DESIGN RYOBI COU SE DOOR CLOSER EXTRA FLAT (30mm) DESIGN



ISO 9002
CERTIFICATO N. A5324



- Extra compatto design per montaggio sovrapposto (spessore 30 mm) ideale per “imbotti” ascensore
 - Qualità ed economia
 - Regolazione velocità di chiusura separata da velocità finecorsa
 - Angolo d’apertura regolabile con arresto elastico
 - Fermoporta regolabile
 - Forza di chiusura 2-3
 - Garantito minimo 500.000 di cicli di funzionamento
 - Montaggio sulla porta o sull’architrave del telaio
- *Extra compact design for overlapping mounting (30 mm thickness), it's ideal for door built-in in the wall*
 - *Quality and economy*
 - *Closing speed regulation is separated from latching speed range*
 - *Opening angle regulated by stop elastic*
 - *Adjustable door stop*
 - *Closing force 2-3*
 - *Minimum 500,000 operating cycles guaranteed*
 - *Mounting on the door or on the lintel of the frame*

ESEMPI DI MONTAGGIO

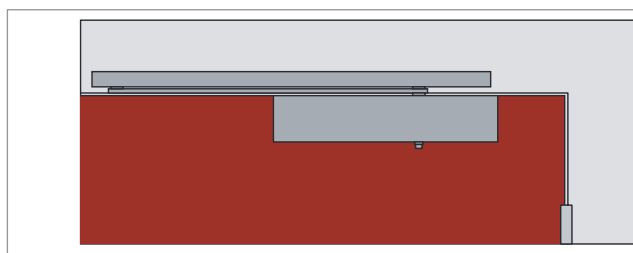

COU 52/53 L - Su porta

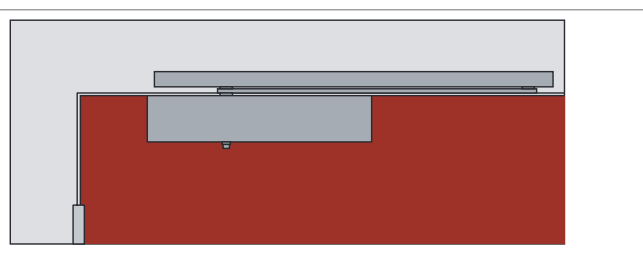

COU 52/53 R - Su porta

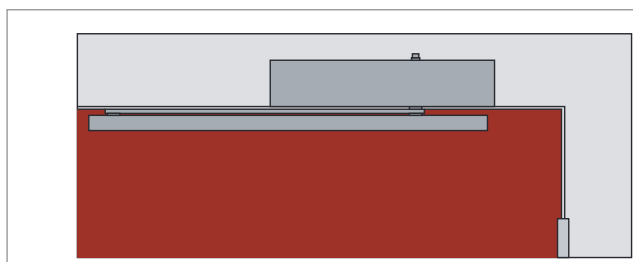

COU 52/53 L - Su architrave del telaio

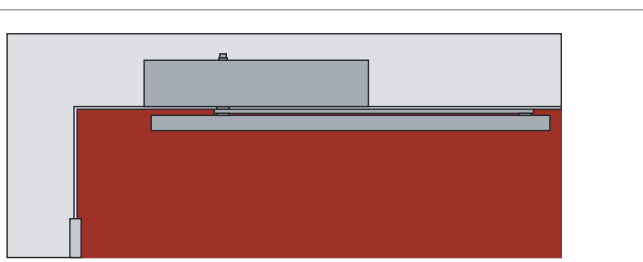

COU 52/53 R - Su architrave del telaio

CHIUDIPIORTA RYOBI COU SE EXTRAPIATTO (30mm) DESIGN RYOBI COU SE DOOR CLOSER EXTRA FLAT (30mm) DESIGN

REGOLAZIONI

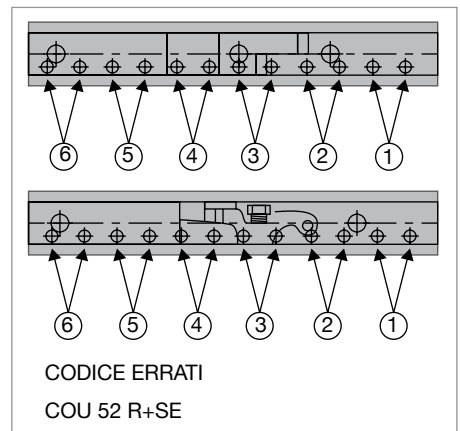
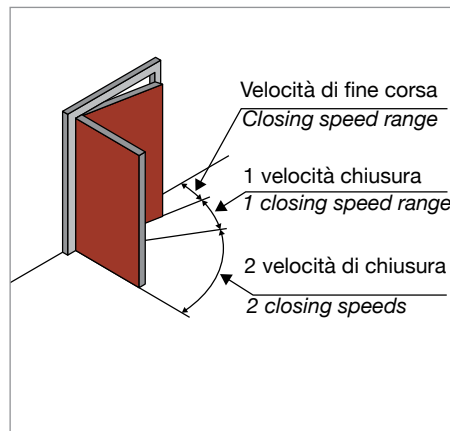
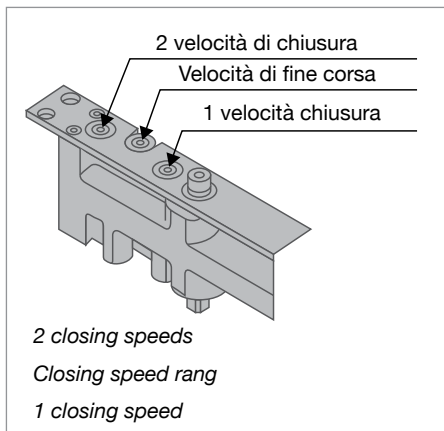

Arresto elastico a posizione regolabile con slitta preforata standard
Elastic stop in adjustable position with standard pre-drilled guide

Fermaporta regolabile su slitta preforata (**cod. ST1**)
Adjustable door stop on pre-drilled guide (code ST1)

Con corpo chiudiporta montato sulla porta lato tirare
With the body of the door closer mounted on the door, pull side

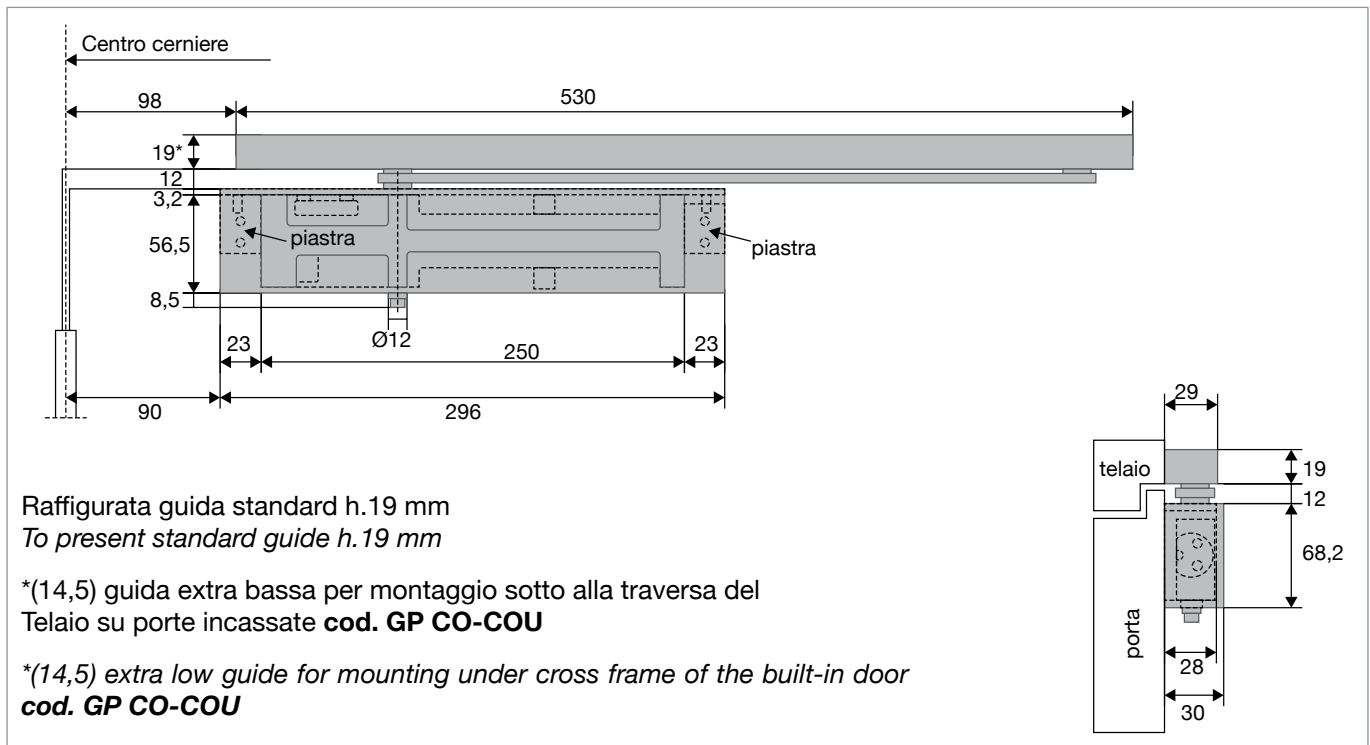

Codice	Dimensione porta	Peso porta
COU 52 R SE	600 - 700 x 2100	45 Kg
COU 52 L SE		
COU 53 R SE	750 - 950 x 2100	65 Kg
COU 53 L SE		

R = tirare a destra (cerniera a sinistra) - **L** = tirare a sinistra (cerniera a destra)

CHIUDIORTA DICTATOR LS FZ E PER MODIFICA DI PORTE MANUALI IN SEMIAUTOMATICHE CON CASSONETTO IN LAMIERA

DOOR CLOSER DICTATOR LS FZ E TO MODIFY MANUAL DOORS IN SEMIAUTOMATIC DOORS WITH METAL SHEET BOX

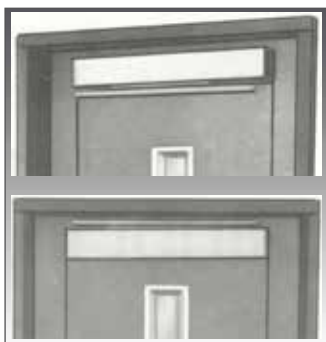

Istruzioni di montaggio

Come da misure sotto riportate a sinistra, posizionare gli angolari di fissaggio A e B, la guida C, montare il chiudiporta con la relativa leva di trasmissione, quindi posizionare il cassonetto di copertura (nel disegno il cassonetto è tratteggiato).

Mounting instructions

As shown by indication to bring back on the left, place the fastening angles A and B, the C guide, mounting the door closer with the relative transmission lever, then to place the dumpster coverage (in the drawing the box is dashed).

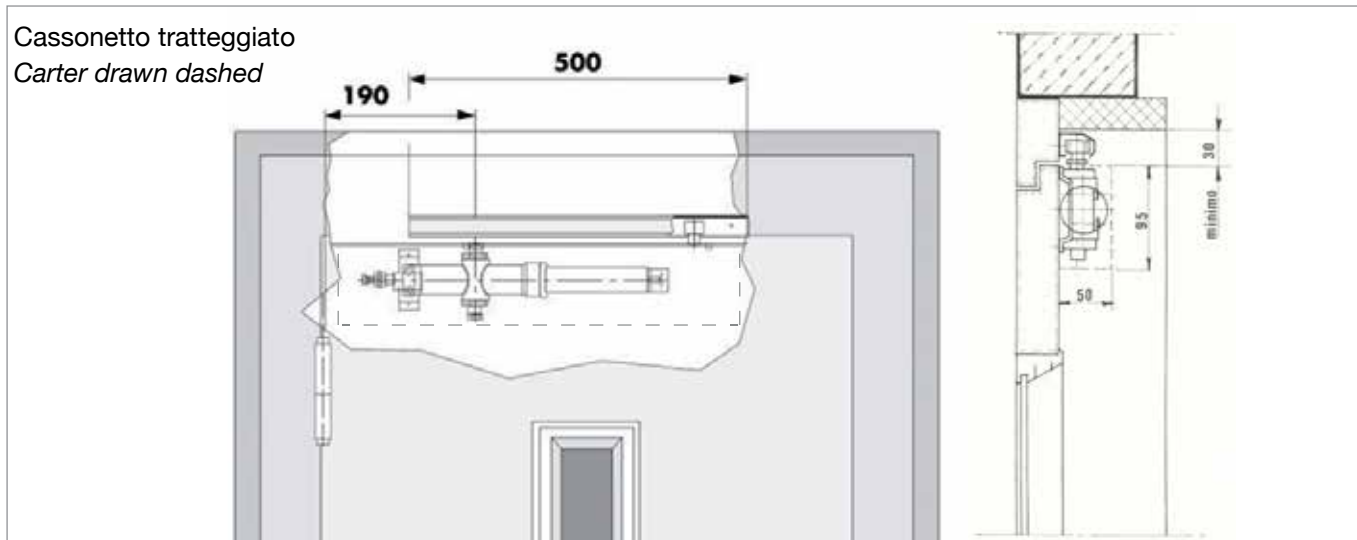
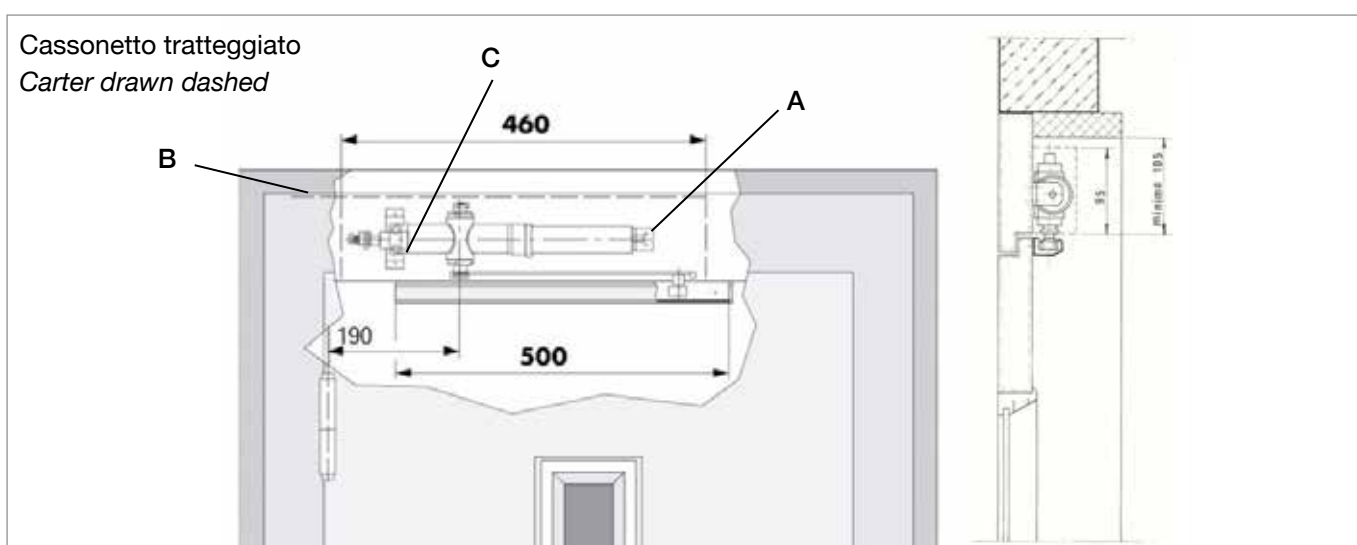

Codice	Descrizione
205121E	Chiudiporta Dictator LS FZ E tipo ROSSO montaggio sul battente e sul telaio / Door closer Dictator LS FZ E type RED mounting on leaf door and on the frame
205124E	Chiudiporta Dictator LS FZ E tipo BLU montaggio sul battente e sul telaio / Door closer Dictator LS FZ E type BLUE mounting on leaf door and on the frame

CHIUDIORTA DICTATOR UNIVERSAL V 1600 PER MODIFICA PORTE DI PIANO D'ASCENSORE CON CERNIERE NASCOSTE DA MANUALI A SEMIAUTOMATICHE

DICTATOR UNIVERSAL V 1600 MODIFICATION OF LIFT FLOOR DOORS WITH INVISIBLE HINGES FROM MANUAL TO SEMIAUTOMATIC

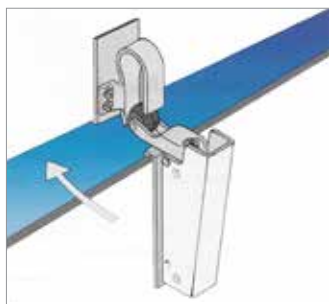

Riscontro 1009 (X = 59) - Riscontro 1013 (X = 78) - Riscontro 1011 (X = 39)

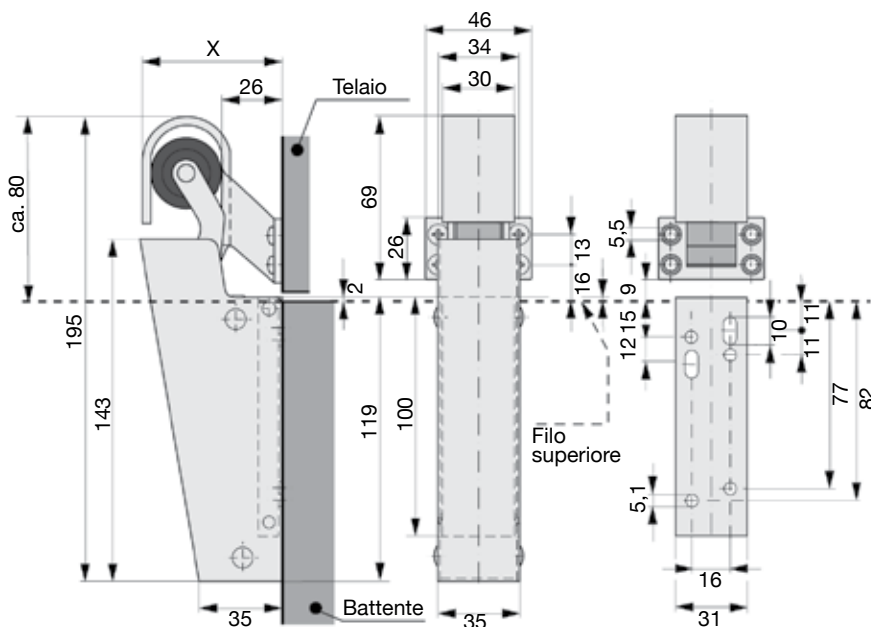

Codice	Forza (N)	Finitura
300464	20	serie V 1600 cromato lucido / V 1600 series polish chrome
300464X	20	serie V 1600 cromato opaco / V 1600 series matt chrome
300610	20	serie V 1600 acciaio Inox / V 1600 series stainless steel
300460	50	serie V 1600 cromato lucido / V 1600 series polish chrome
300462	50	serie V 1600 acciaio inox / V 1600 series stainless steel
300480	80	serie V 1600 cromato lucido / V 1600 series polish chrome
300485	80	serie V 1600 acciaio inox / V 1600 series stainless steel

Note: Cromato opaco uguale argento

Note: Matt chrome is like silver colour

Adatto a porte con qualsiasi cerniera

Suitable for doors with any hinge

Su richiesta chiudiporta V 1600 con colorazioni in scala RAL.

Door closer V1600 in RAL colours **on request**.

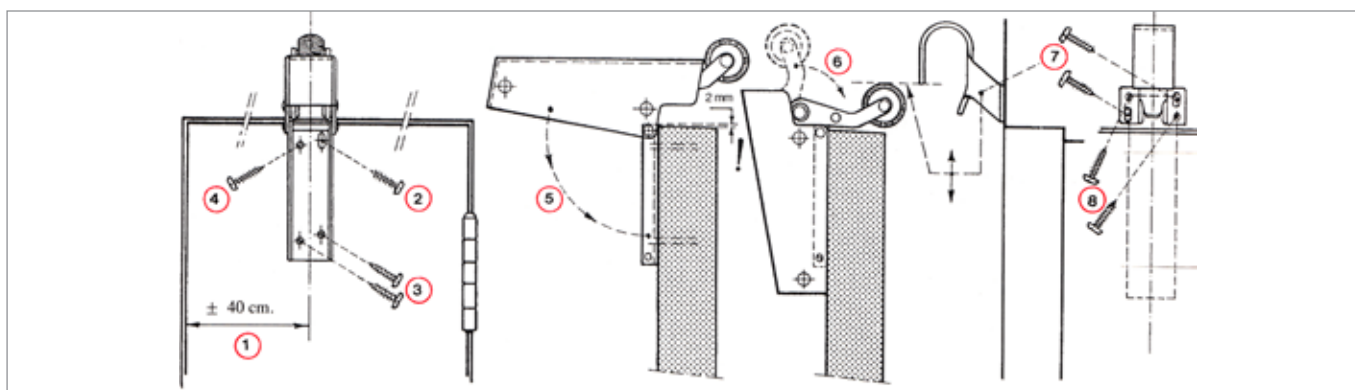

CHIUDIPIORTA DICTATOR UNIVERSAL R 1400 DICTATOR UNIVERSAL R 1400 DOOR CLOSER



Il chiuditore Dictator Universal R1400 è un'esecuzione rovesciata già dotata di carter di copertura che si abbina perfettamente al riscontro della rotella con piastra di montaggio ribaltabile per una rapida e facile installazione.

Montaggio

Se la porta nel vano corsa non è murata a filo vano corsa ascensore e tra la soglia della cabina è minimo 55mm o superiore, si può montare il Dictator R1400 sullo spigolo della porta opposto alla cerniera lato spingere.

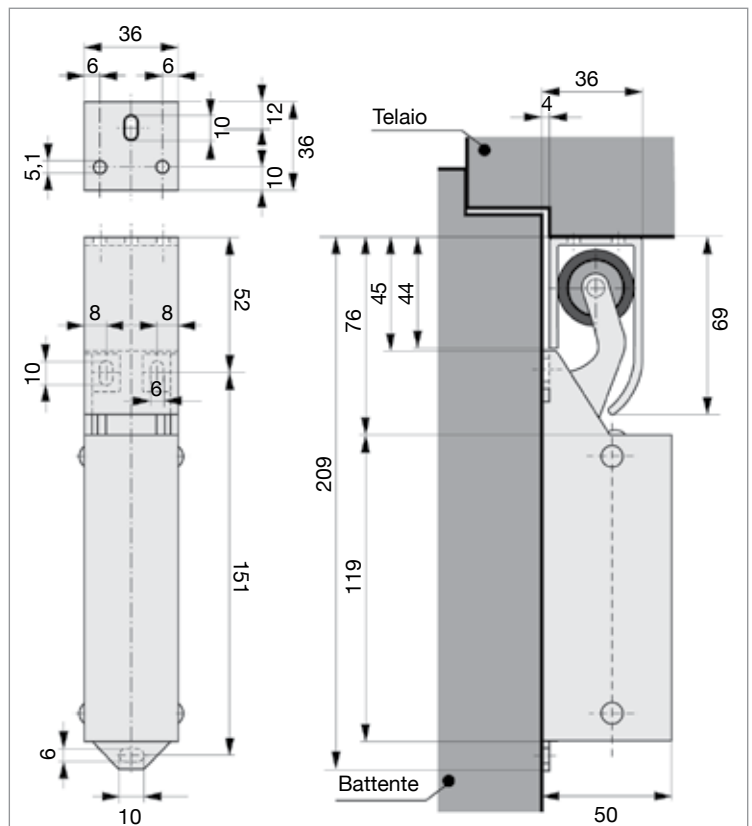
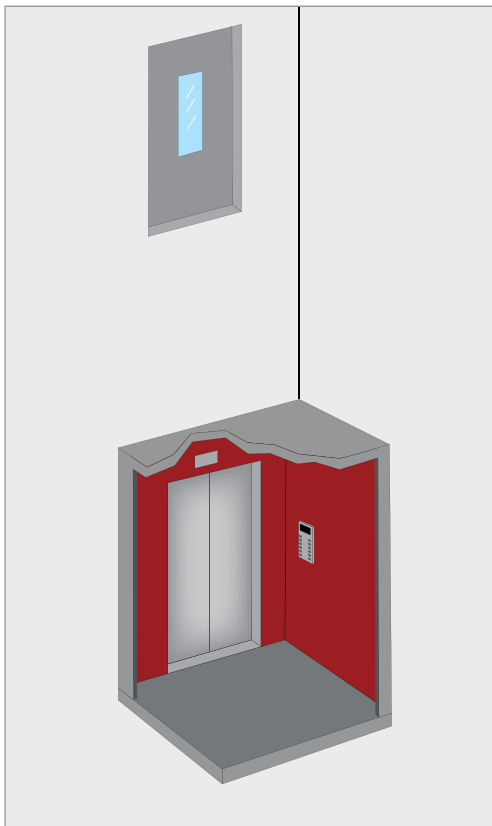

Su richiesta chiudiporta R1400 con colori in scala RAL.
On demand door closer R1400 in RAL colours.

Note: Cromato opaco uguale argento

Note: Matt chrome is like silver colour

Codice	Descrizione	Forza (N)	Finitura
300473	Dictator Universal R 1400	20	Dorato / golden
300970	Dictator Universal R 1400	20	Marrone RAL 8017 / RAL 8017 brown
300387	Dictator Universal R 1400	20	Cromato lucido / polish chrome
300387X	Dictator Universal R 1400	20	Cromato opaco / matt chrome
300625	Dictator Universal R 1400	20	Acciaio Inox / Stainless steel
300475	Dictator Universal R 1400	50	Cromato lucido / polish chrome
300475X	Dictator Universal R 1400	50	Cromato opaco / polish chrome
300626	Dictator Universal R 1400	50	Acciaio Inox/ Stainless steel

CHIUDIPIORTA DICTATOR UNIVERSAL H 1300 DICTATOR UNIVERSAL DOOR CLOSER H 1300



Chiudiporta Dictator "UNIVERSAL H 1300"

1. Decelerazione progressiva
2. Regolazione semplice: girando in senso orario aumenta la decelerazione girando in senso antiorario diminuisce la decelerazione
3. Bronzine in metallo autolubrificante
4. Olio atermico
5. Cilindro ricavato da unico pezzo
6. Rotella in gomma antiusura con bronzina
7. Impianto robotizzato per collaudo del 100% dei chiudiporta prodotti

Dictator door closer "UNIVERSAL H 1300"

1. Deceleration progressive
2. Simple adjustment: turning clockwise increase the damping, turning counter clockwise decrease the progressive damping
3. Bearings in autolubricant
4. Atermic oil
5. Cylinder made from a unique piece
6. Wear-resistant rubber roller with bearing
7. Robotic system for testing 100% of door closers products

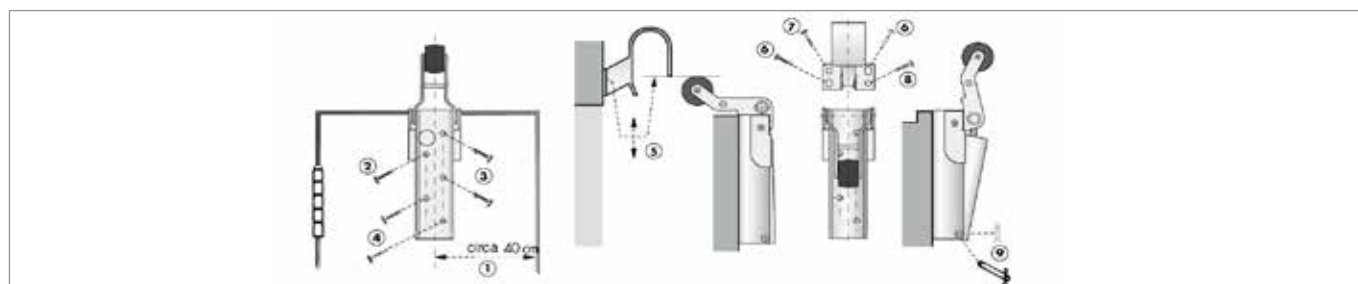
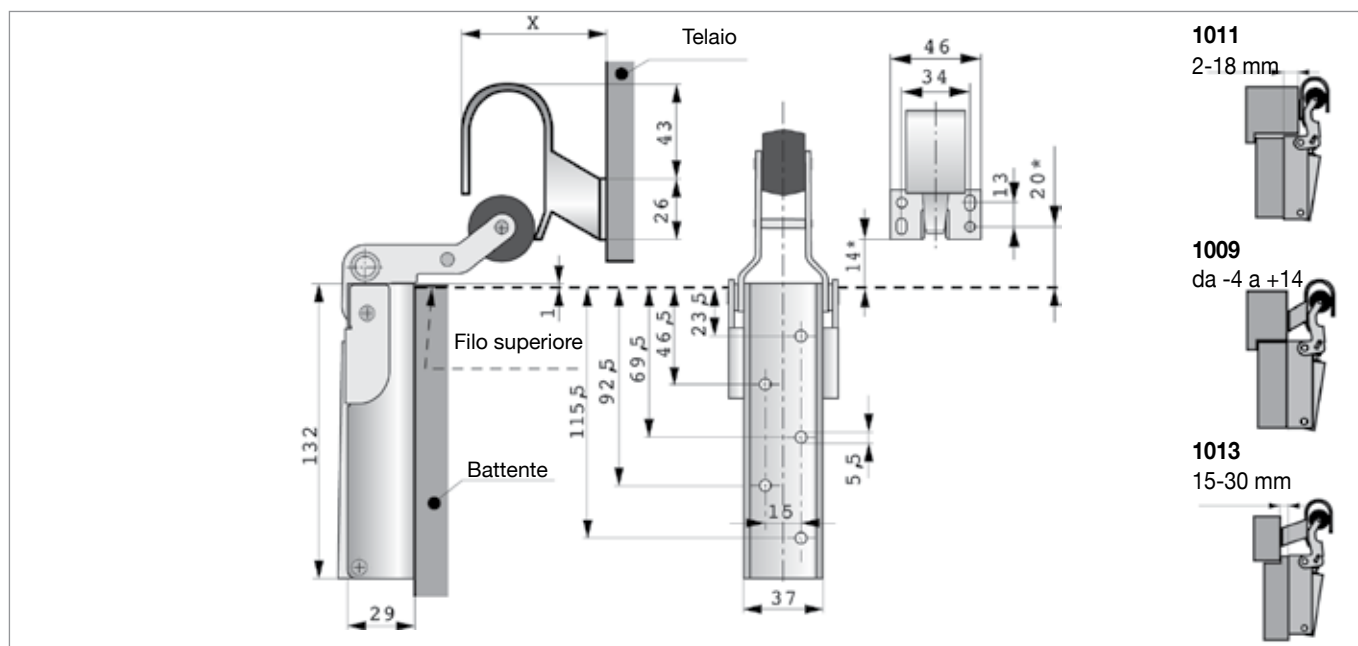

Codice	Descrizione	Riscontro	Forza (N)	Finitura
300100	Dictator Universal H 1300	1013	50	Nichelato - <i>nickel</i>
300110	Dictator Universal H 1300	1009	50	Nichelato - <i>nickel</i>
300130	Dictator Universal H 1300	1013	80	Cromato lucido - <i>polish chrome</i>
300140	Dictator Universal H 1300	1009	80	Nichelato - <i>nickel</i>

CHIUDIPIORTA DICTATOR UNIVERSAL Z 1000 DICTATOR UNIVERSAL DOOR CLOSER Z 1000



Chiudiporta Dictator "UNIVERSAL Z 1000"

1. Decelerazione progressiva
2. Regolazione semplice: girando in senso orario aumenta la decelerazione, girando in senso antiorario diminuisce la decelerazione
3. Bronzine in metallo autolubrificante
4. Olio atermico
5. Cilindro ricavato da unico pezzo
6. Rotella in gomma antiusura con bronzina
7. Impianto robotizzato per collaudo del 100% dei chiudiporta prodotti

Dictator door closer model "UNIVERSAL Z 1000"

1. Deceleration progressive
2. Simple adjustment: turning clockwise increase the damping, turning counter clockwise decrease the progressive damping
3. Bearings in autolubricant
4. Atermic oil
5. Cylinder made from a unique piece
6. Wear-resistant rubber roller with bearing
7. Robotic system for testing 100% of door closers products

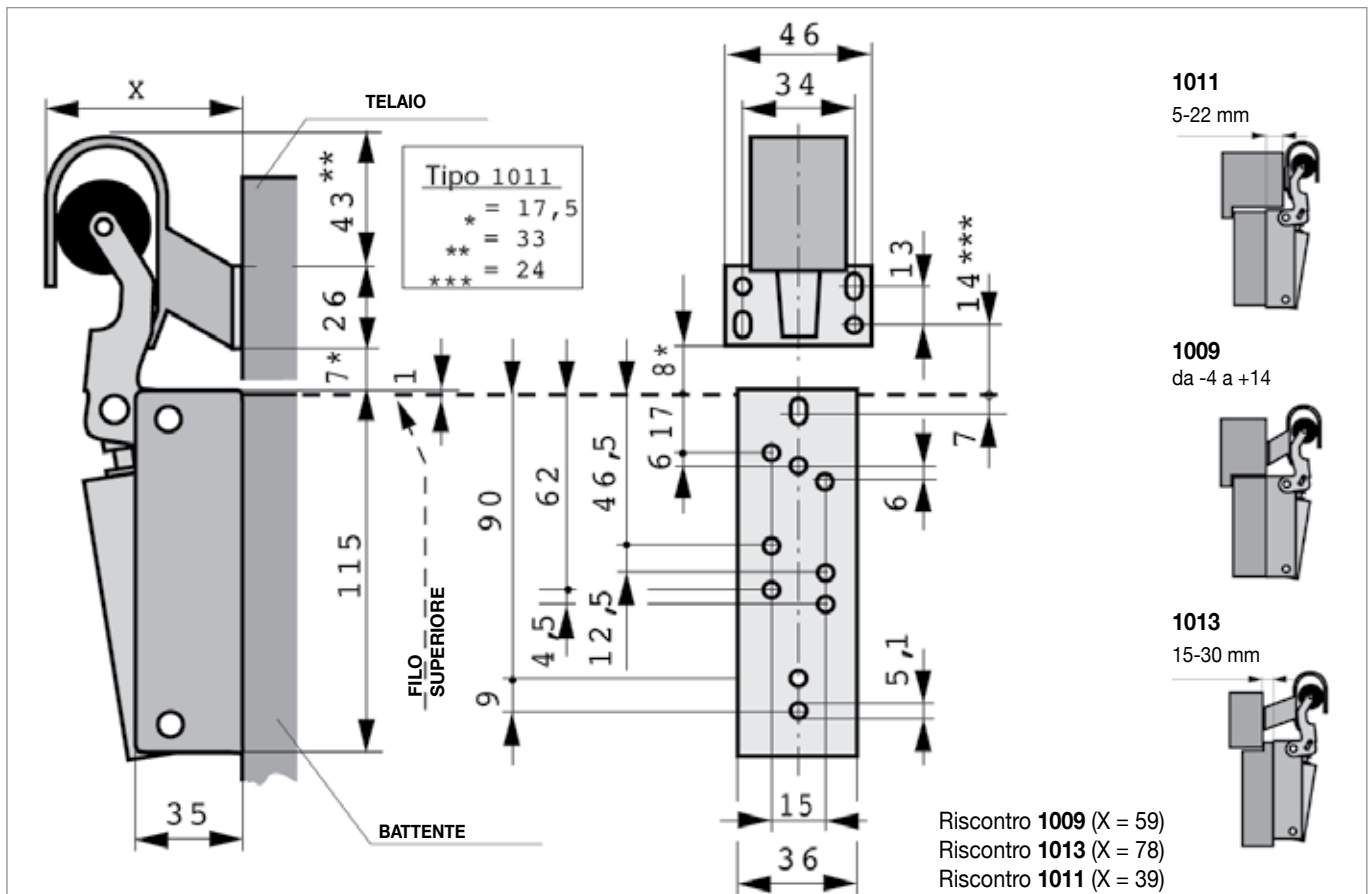

Codice	Descrizione	Riscontro	Forza (N)	Finitura - Finishing
300373	Chiudiporta Dictator Universal Z 1000	1009	50	Nichelato - nickel
300374	Chiudiporta Dictator Universal Z 1000	1011	50	Nichelato - nickel
300375	Chiudiporta Dictator Universal Z 1000	1013	50	Nichelato - nickel

CHIUDIPIORTA DICTATOR JUNIOR PER PORTINE A BATTENTE DELLE CABINE ASCENSORE

DICTATOR JUNIOR DOOR CLOSER FOR SMALL DOORS FOR CABIN LIFT

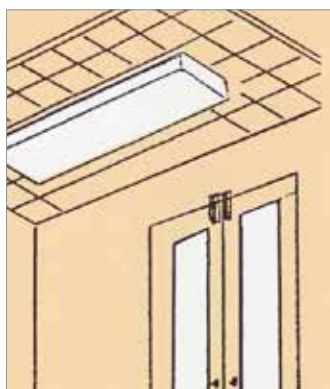

Il chiuditore Dictator Junior è stato disegnato per portelli, cassette scorrevoli e per portine a battente di cabina ascensore.

Il chiudiporta Dictator Junior decellera e chiude le portine delle cabine ascensore eliminando il problema di falsi contatti soprattutto in vecchi impianti non rinnovati.

*The Dictator door closer Junior has been designed for doors, sliding drawers and for lift with hinged cabin door .
The Dictator door closer Junior decelerated and closed the door cabin of lift, resolving the problem of false contacts especially in the old implant which not renewed yet.*

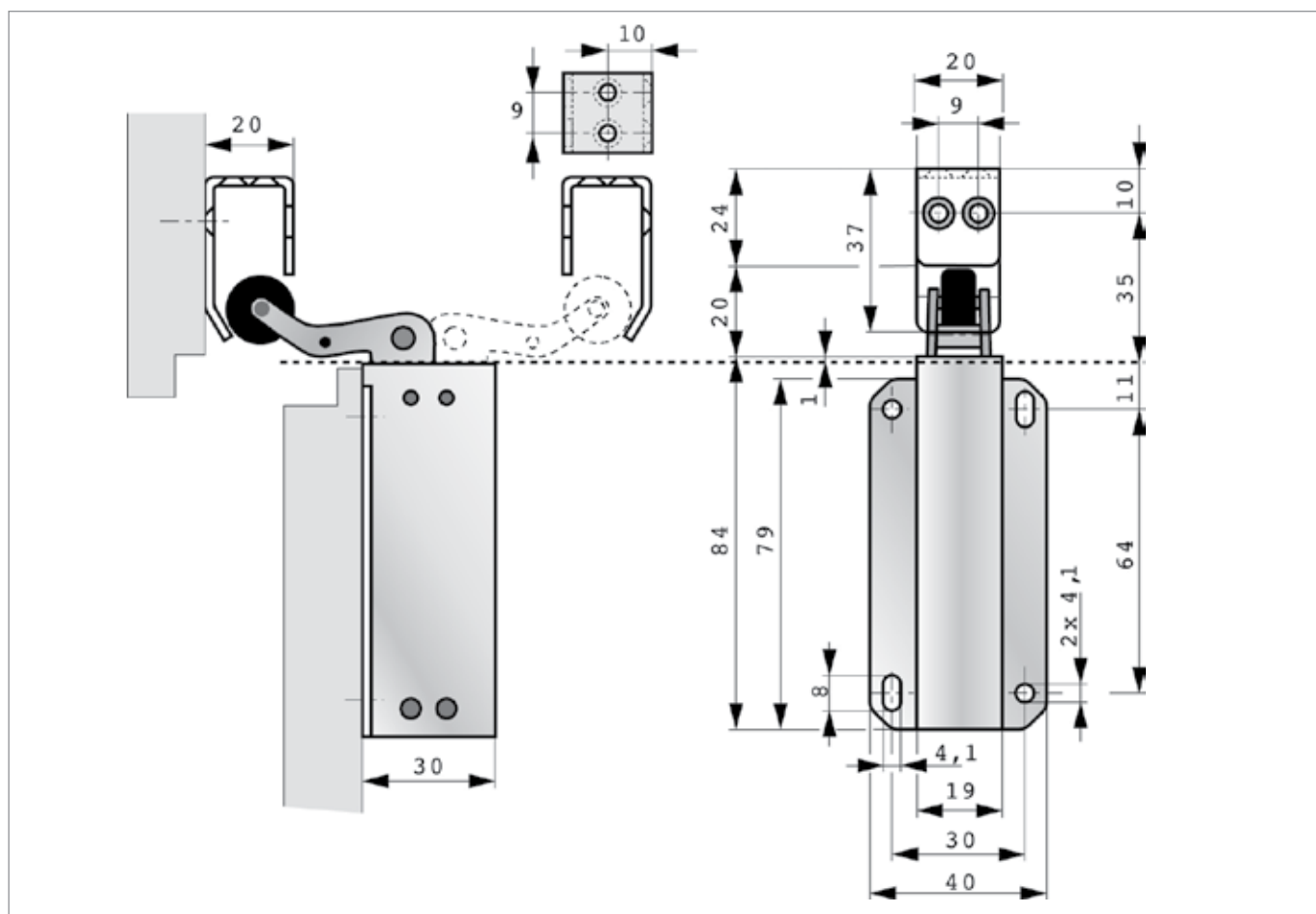

Codice	Tipo	Riscontro	Forza (N)	Finitura - Finishing
392000	DICTATOR Junior (lato tirare)	1009	13	Inox - Stainless steel
392020	DICTATOR Junior (lato spingere)	1009	13	Inox - Stainless steel

MINI DICTA TROLLEY LD50 PER DECELERAZIONE DI PORTE SCORREVOLI SABIEM

MINI DICTA TROLLEY LD50 TO DECELERATE SABIEM SLIDING DOORS

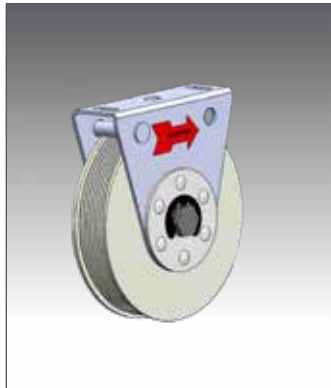

Ante a chiusura laterale

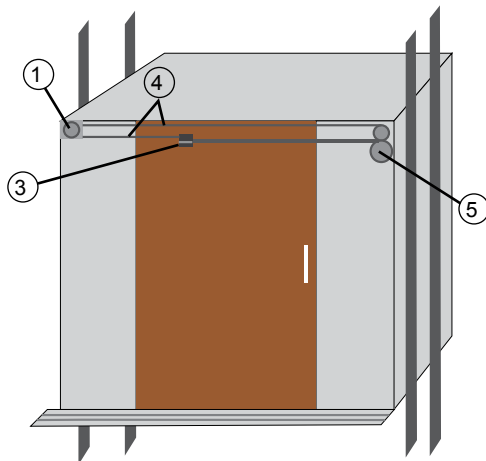

1. Dicta trolley LD50 regolabile 3. Attacco cavo porta
2. Puleggia 4. Cavo

Ante assimetriche a chiusura centrale

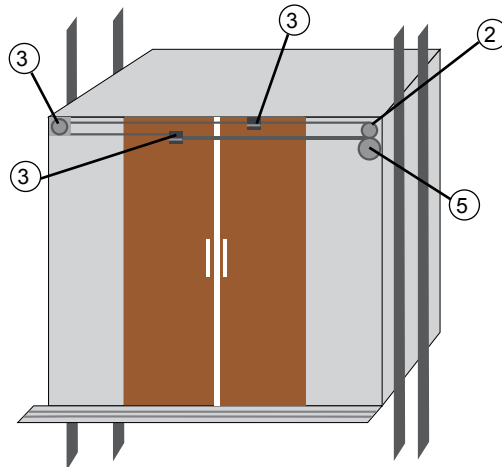

5. Molla a bobina cod. 070102

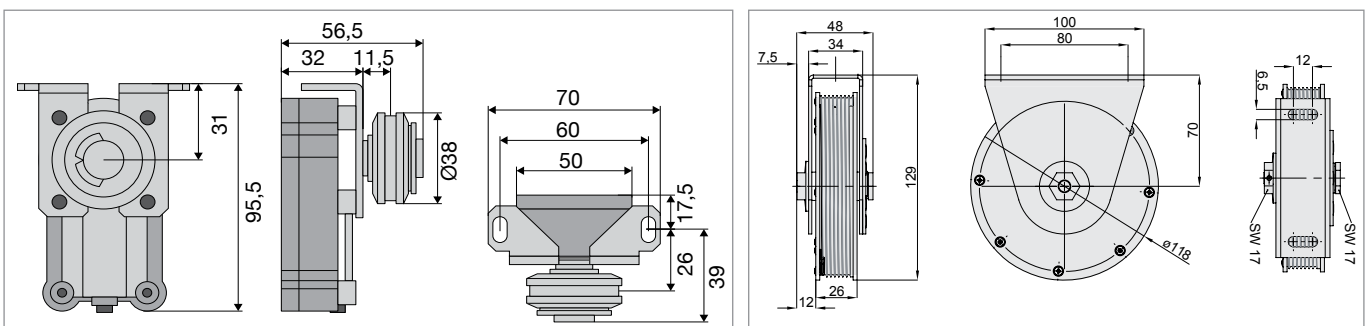

I mini Dicta trolley LD50 servono per regolare la velocità di chiusura di porte scorrevoli. La loro velocità di chiusura può essere regolata tramite una vite di registro posta sull'asse centrale.

The mini Dicta trolley LD50 are employed to regulate the closing speed of sliding door. Theirs closing speed can be regulated by one screw of regulator that placed on the central axis.

Codice	Tipo
244045	Mini Dicta Trolley LD50
700071	Attacco cavo porta / door rope tensioner
700075	Puleggia, mini trolley con angolare / pulley, Mini trolley with angular
780994	Cavo di trazione Ø 2mm / traction cable Ø 2 mm
070102	Molla a bobina con cavo e supporto corsa 1 m / coil spring with cable and stroke support

FERMO PORTA AEREO DOOR STOP OVERHEAD



Montaggio sovrapposto lato tirare innesto, e disinnesto muovendo la porta.

Overlapping mounting side pull insert and dis inserted by moving the door.

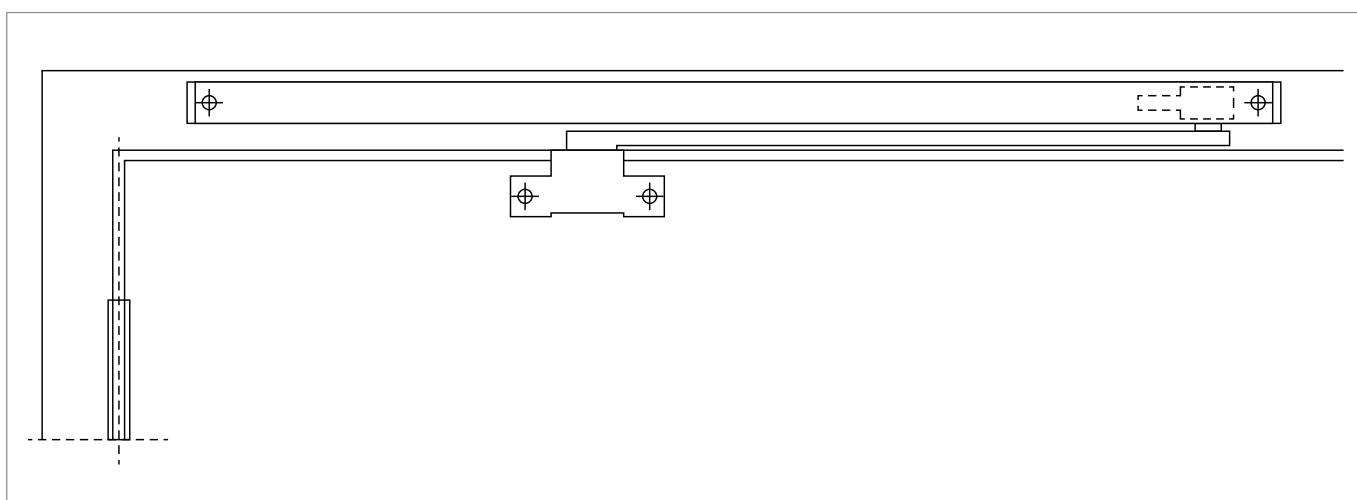

Codice	Descrizione
FPS 03	Fermo porta + braccio a slitta (guida 20 x 30) / Door stop + slide arm (guide 20 x 30)

NOTE

AMMORTIZZATORI

DAMPERS

Ammortizzatori Dictator porte a battente STAHL - OTIS - AKRON	2.2
<i>Dictator hinged doors dampers of STAHL - OTIS - AKRON</i>	
Ammortizzatori Dictator per operatori di ascensori e operatori ascensore STAHL	2.3
<i>The Dictator dampers for lift door operator and STAHL lift operator</i>	
Ammortizzatore Dictator idraulico intercambiabile per ammortizzatori ad aria FORSID, BENEMATIC, CEITA	2.4
<i>The Dictator interchangeable hydraulic air damper for the FORSID, BENEMATIC, CEITA</i>	
Ammortizzatori per fossa idraulici	2.5
<i>Hydraulic dampers with pit</i>	
Ammortizzatore per elettromagnete del pattino retrattile BASSETTI	2.6
<i>Damper for electromagnetic of retiring cam BASSETTI</i>	
Ammortizzatore elettromagnete per pattino retrattile FIAM	2.7
<i>Damper for electromagnetic for retiring cam FIAM</i>	

Note: I componenti sul catalogo con riportata una specifica marca di ascensore sono utilizzati abitualmente solo da questa marca. I particolari senza marca sono utilizzati da più marche di ascensori.

Note: The components in the catalogue with a specific lift brand are usually used only by the brand. Unbranded parts are used by multiple lift brands.

AMMORTIZZATORE DICTATOR ED STD 3 PER ASCENSORI AKRON - FLORH - OTIS - STAHL

DICTATOR DAMPERS ED STD 3 FOR AKRON - FLORH - OTIS - STAHL LIFT



Gli ammortizzatori per porte a battente Dictator ED STD 3 sono prodotti di qualità con corpo pressofuso, sono installabili su porte con peso variabile da 20 a 200 kg, per ascensore AKRON - STAHL - FLOHR - OTIS. Con gli ammortizzatori Dictator ED STD 3 la regolazione della frenata avviene in senso orario per aumentare il ammortizzazione, e per ottenere l'opposto in senso antiorario. La regolazione avviene mediante rotazione dell'asta.

The DICTATOR ED STD 3 hinged door damper is designed for the final damping of hinged doors being closed by spring. The damper is installed in door frame and is accessible through the lift shaft.

The piston rod of damper points through the door frame and makes contact with the side of door when the door is closed. To protect the sheet steel on the door frame steel on the door from wear, a special hardened counter plate for the piston rod needs to be fixed to the point where the piston rod meets the door.

The ED STD 3 damper works hydraulically. This guarantees that the ED STD 3 slows down and effectively damps the door as soon as it hits the piston.

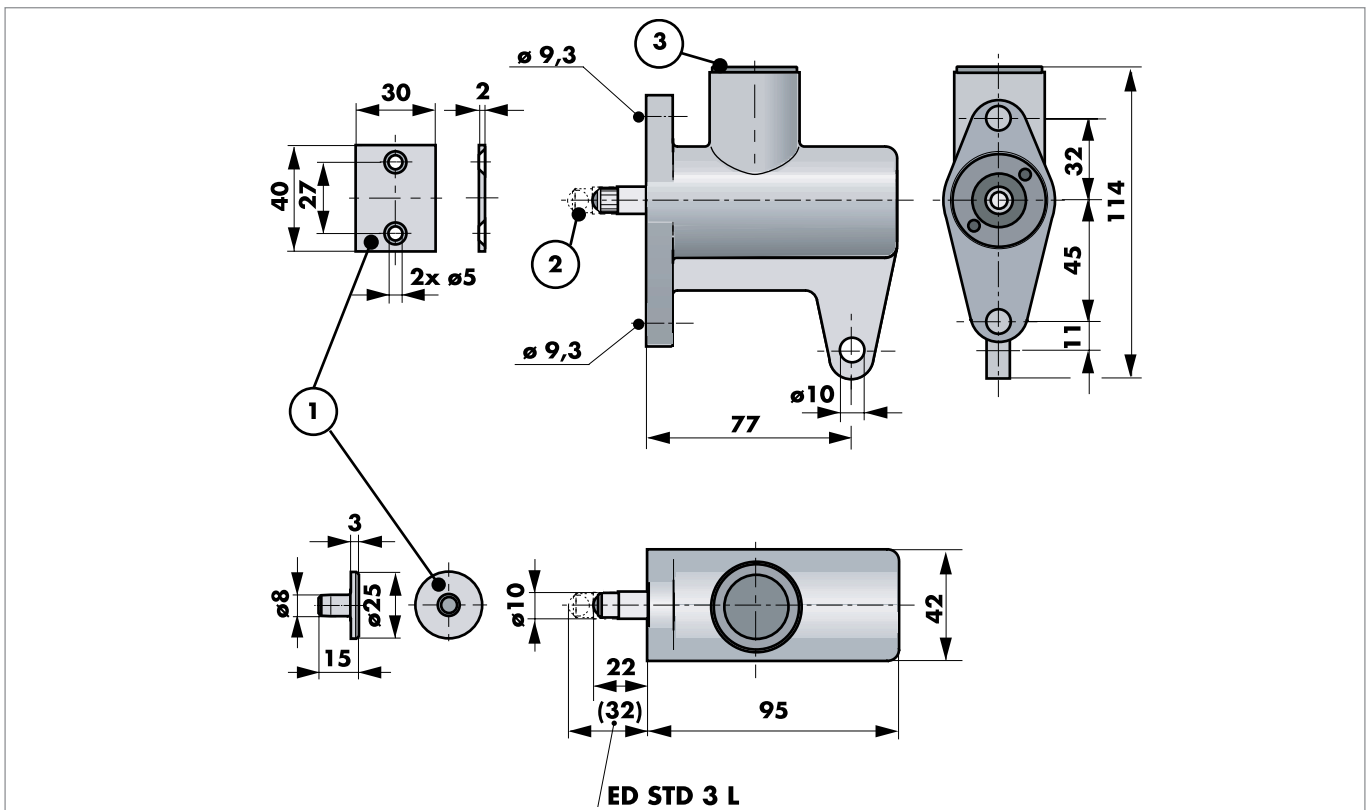

Codice	Tipo - Type	Finitura
203401	EDSTD 3	Ammortizzatore regolabile per ascensore AKRON - STAHL / Adjustable damper for AKRON - STAHL lift
203402	EDSTD 3L	Ammortizzatore regolabile con stelo lungo per ascensore FLORH - OTIS / Adjustable damper with long rod for FLORH - OTIS lift
205141	Accessori	Piastra di battuta angolare sp. 2mm solo per ascensori STAHL / angular stop plate with 2mm thickness only for STAHL lift
205188	Accessori	Piastra di battuta rotonda solo per ascensori FLORH - OTIS Round stop plate only for FLORH - OTIS lift

AMMORTIZZATORE DICTATOR PER OPERATORI ASCENSORI E PER OPERATORE ASCENSORE STAHL
DICTATOR DAMPERS FOR OPERATORS AND LIFT STAHL OPERATOR

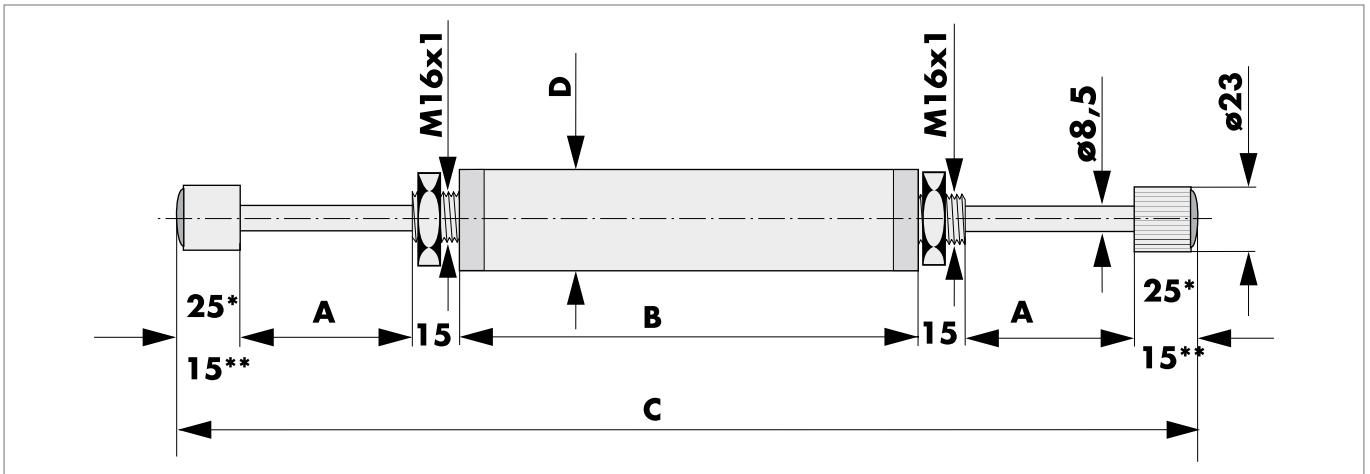
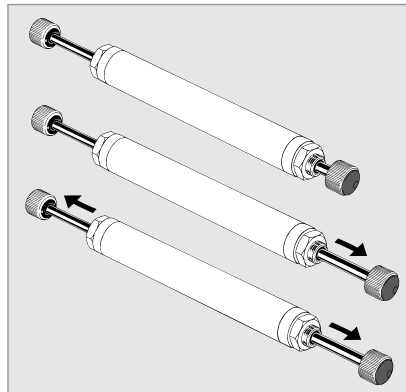

Tipo - Type	Finitura
a	Uscita automatica dello stelo in posizione di lavoro / <i>automatically extending piston rod</i>
a/EG	Uno stelo con uscita automatica, un stelo viene comandato in posizione di lavoro dell'entrata dell'altro stelo ad uscita automatica in posizione di lavoro / <i>one piston rod extending automatically, one piston rod pushed outwards by the other</i>
BG	Steli a moto alternato comandati rispettivamente in uscita dall'entrata di quello opposto / <i>Piston rods move each other to the outside</i>
P	Decelerazione progressiva, regolazione tramite registro a steli completamente fuoriusciti / <i>Progressive damping, to escape the rod completely, stopping shaft through regulator</i>

Codice	Tipo - Type	Dimensioni - Dimension			
		A	B	C	D
210110	ZDH 50/50 BG	50	137	297	28
210000	ZDH 50/50 a	50	137	297	28
203190	ZDH 50/50 a/EG/P	50	220	400	28
203191	ZDH 70/70 a/EG/P	70	260	480	28
203195	ZDH 50/50 BG	55	132	255	35
203162	ZDH 120 BG per ascensori STAHL	120	208	408	28

AMMORTIZZATORE IDRAULICO REGOLABILE DS DICTATOR PER PORTE SOFFIETTO FORSID (BENEMATIC) E PER PORTE A LIBRO CEITA DS DICTATOR HYDRAULIC DAMPER ADJUSTABLE FOR FORSID DOORS (BENEMATIC) AND CEITA DOORS



L'ammortizzatore idraulico DS Dictator sostituisce senza modifiche l'ammortizzatore in plastica ad aria per porte a soffietto FORSID-BENEMATIC. L'ammortizzatore è regolabile mediante la rotazione dell'asta, il suo funzionamento avviene con aste a movimentazione alternata (quando una entra spinge fuori l'altra)

The hydraulic damper DS Dictator can be replaced without modification of the damper air plastic for FORSID-BENEMATIC folding door. The damper is adjustable by rotating the rod, its function take place with alternating handling rod (when one enters pushes out the other).

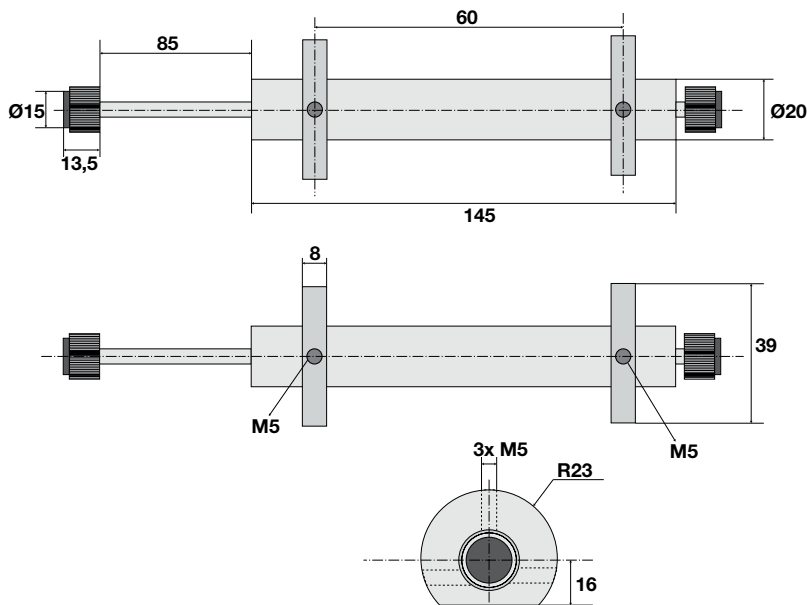

Codice	
210110X	

**FUORI PRODUZIONE SOSTITUTO DAL CODICE 210110X
OUT OF PRODUCTION SUBSTITUTE BY THE CODE 210110X**

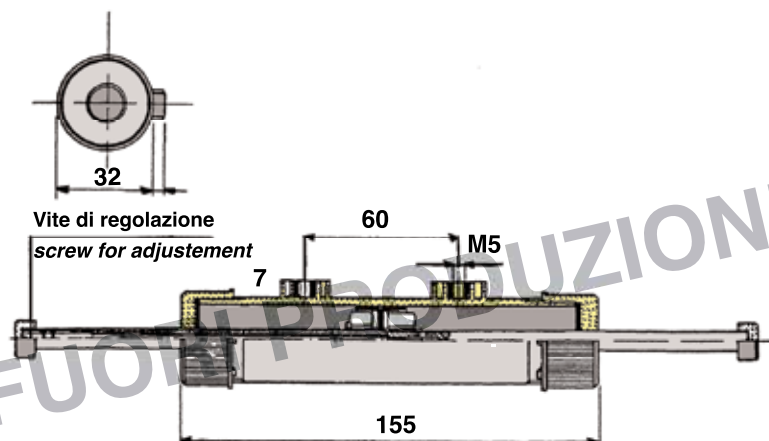

AMMORTIZZATORE OLEODINAMICO IN FOSSA HYDRAULIC DAMPER IN PIT

2



Ammortizzatore corrispondente alle normative Europee con certificazione CEE.

Damper corresponding to the European standard with CEE certification.

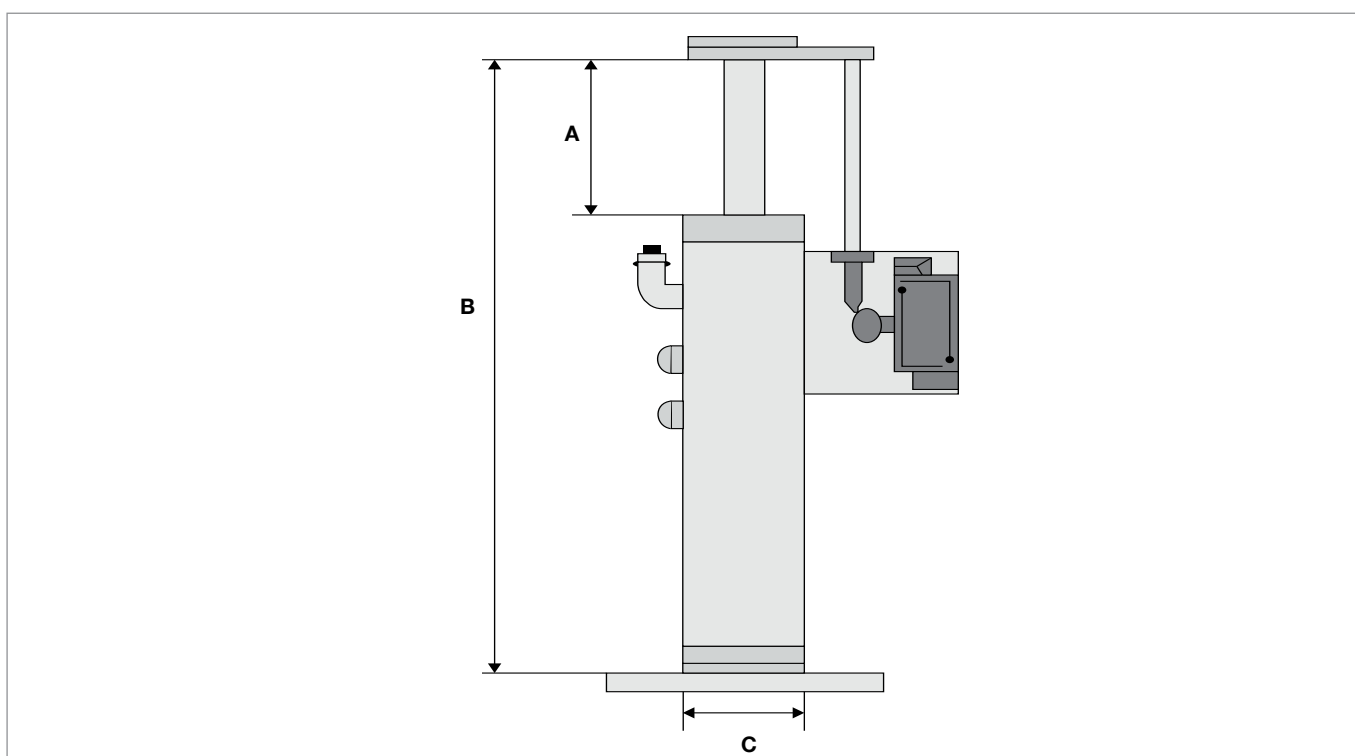

Art.	Tipo	A RUN	B	C	peso Amm kg	Q.ta olio	Carico kg min -max	Velocità m/sec. min - max
M004	201	95	405	100	16	2	300 - 2000	0,63 - 1,00
M005/1	202	180	555	100	20	2	300 - 2000	1,00 - 1,60
M006	203	280	815	100	25	2,5	300 - 2000	1,61 - 2,00
M007	301	95	410	100	20	2,5	500 - 3000	0,63 - 1,00
M008/1	302	560	160	100	22	3	500 - 3000	1,00 - 1,60
M009	303	280	820	120	25	3	500 - 3000	1,61 - 2,00

Caratteristiche olio

Y	0,87 KP/dm ³
V	4 - 7E° A 50°C
I.V.	>100

AMMORTIZZATORE PER ELETTROMAGNETE PATTINO RETRATTILE BASSETTI

DAMPER FOR ELECTROMAGNETIC OF RETIRING CAM BASSETTI

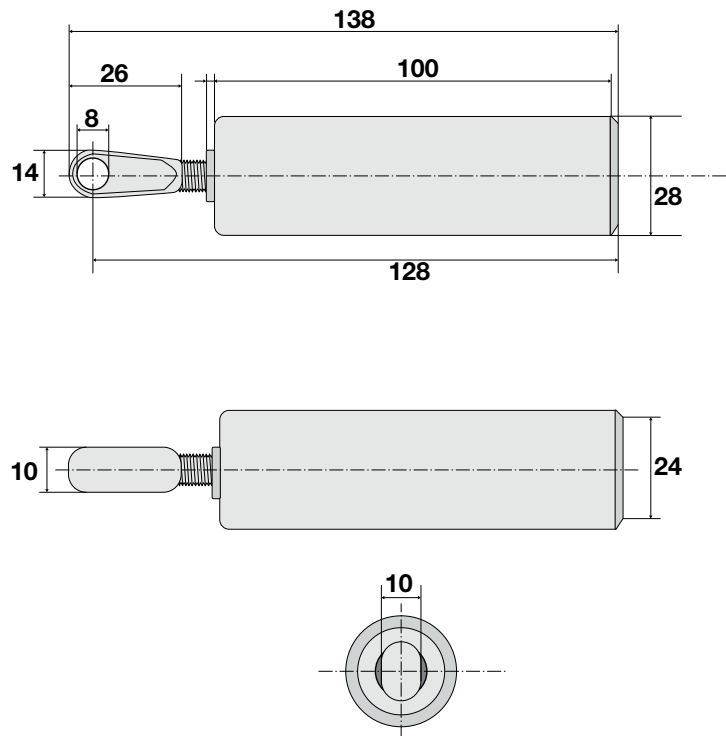

Codice	Descrizione / Description
205380	<p>Se necessario in caso si voglia un azionamento più veloce causa tolleranza dell'appoggio della fusione dell'elettromagnete spessorarlo con 2 rondelle per uno spessore di 2/4 mm.</p> <p><i>If necessary, whether you want a faster movement due to the tolerance of the support of the electromagnet fusion, insert 2 washer for a total thickness of 2/4 mm.</i></p>

AMMORTIZZATORE IDRAULICO PER PATTINO RETRATTILE FIAM
HYDRAULIC DAMPER FOR RETIRING CAM FIAM

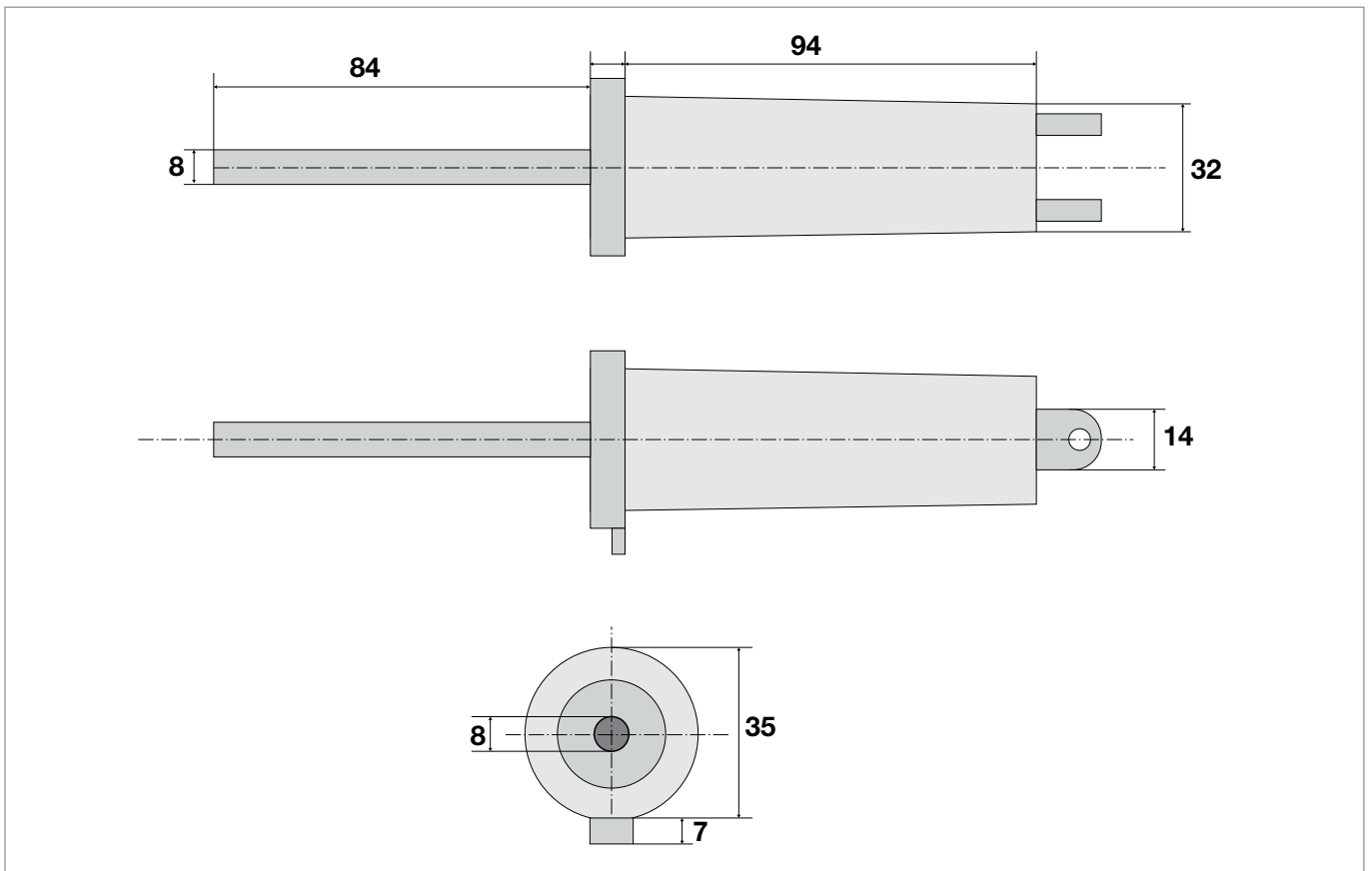

Codice	Tipo	Descrizione / Description
4510/2	FIAM LG 47	Ammortizzatore idraulico per elettromagnete con pattino retrattile incorporato FIAM <i>Hydraulic damper for electromagnet with built-in retiring cam FIAM</i>

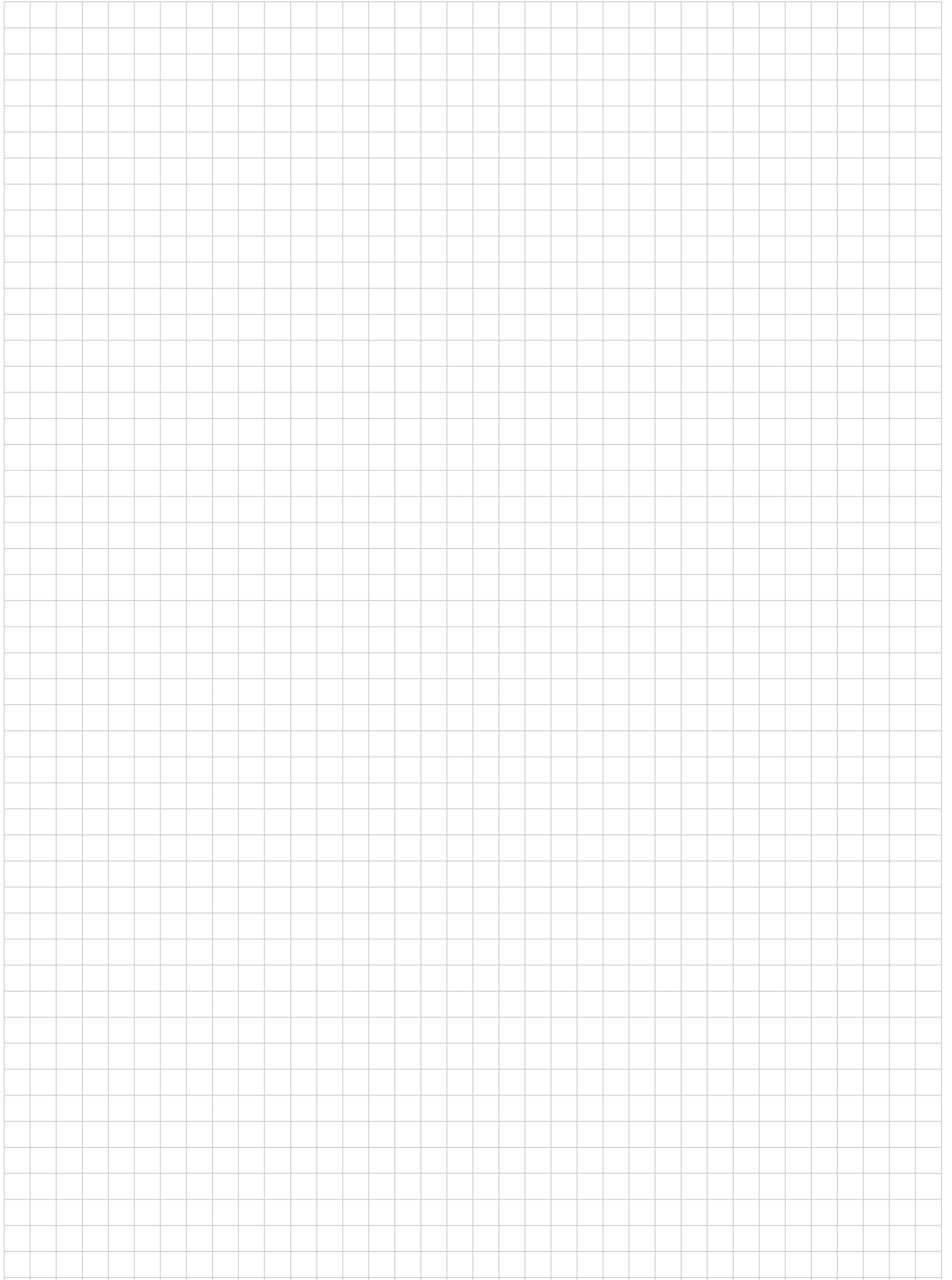

NOTE

**CONTATTI PONTI PORTE PORTINE OPERATORI SOSPENSIONI FINECORSA AD ASTA MICROSWITCHES
INTERRUTTORI A CHIAVE ESTRAIBILE STANDARD, BASSETTI, FOSID - MONITOR, CEAM, OTIS, FALCONI,
IGV, SELCOM, SCHINDLER, SAFOV, SCHLIEREN, KRONENBERG, FIAM, FALCONI, SABIEM, CMM
CENTODUCATI**

**DOOR CONTACTS FOR DOOR OPERATOR, HANGER, LIMIT SWITCHES, MICROSWITCHES, KEY SWITCH
STANDARD, BASSETTI, FORSID - MONITOR, CEAM, OTIS, FALCONI, IGV, SELCOM, SCHINDLER, SAFOV,
SCHLIEREN, KRONENBERG, FIAM, FALCONI, SABIEM, CMM, CENTODUCATI**

Contatto a doppio spillo IGV 3.10
Double bridge contact IGV

Contatto a pistoncino automatismo S FIAM 3.14
Piston contact for automatic S FIAM

Contatto a spillo singolo IGV 3.11
Single bridge contact IGV

Contatto a squadra KRONENBERG 3.13
Square contact KRONENBERG

Contatto a striscio cancelli BASSETTI, IGV 3.9
Contact with strip gate BASSETTI, IGV

Contatto a 1 pistone - doppio SCHLIEREN TK 3.26
Contact with 1 piston - double SCHLIEREN TK

Contatto accostamento KRONENBERG WZV2 con circuito di sicurezza e elettrochiavistello IP54 3.25
Set contact KRONENBERG WZV2 with circuit security and actuator IP54

Contatto BASSETTI portine - CENTODUCATI operatore, KRONENBERG WZA con ponte a forcella BBA 3.28
Door contact BASSETTI - centoducati operator, KRONENBERG WZA with bridge and actuator BBA

Contatto finecorsa ad asta a sfera - rotella pistone 1cnc - 1 cnc + cna 3.30
Limit switch contact rod with ball - roller piston 1cnc - 1 cnc + cna

Contatto finecorsa a sfera a tampone e rotella 1cnc + cna + cnc 3.31
Limit switch rod with pad and roller 1cnc + cna + cnc

Contatto finecorsa a rotella apertura / chiusura simile microswitch automatismo FIAM 3.29
Limit switch contact with opening roller / closing similar microswitch automatic FIAM

Contatto KRONENBERG ATEX entrata ponte a forcella da davanti da dietro da sotto 3.26
Contact KRONENBERG ATEX entrance of actuator from front or back or under

Contatto KRONENBERG PZ 73 entrata fronte - retro	3.24
<i>Contact KRONENBERG PZ 73 front - back entrance</i>	
Contatto KRONENBERG RZ per porte scorrevoli	3.24
<i>Contact KRONENBERG RZ for sliding door</i>	
Contatto KRONENBERG stagno IP66 e suo ponte	3.24
<i>Contact KRONENBERG watertight IP 66 and its bridge</i>	
Contatto KRONENBERG WZF 2S stagno IP 66 per porte a ghigliottina	3.25
<i>Contact KRONENBERG WZF 2S watertight IP66 for guillotine door</i>	
Contatto operatore BASSETTI, FORSID - MONITOR, KRONENBERG	3.5
<i>Operator contact BASSETTI, FORSID - MONITOR, KRONENBERG</i>	
Contatto operatore e sospensioni DAPA MEL081-082-083	3.6
<i>Operator and hanger contact DAPA MEL081-082-083</i>	
Contatto OTIS - ORLY OTIS - NEW YORK 6904A e 6904B - set coppia contatti NEWYORK 6904A	3.17
<i>OTIS contact ORLY OTIS - NEW YORK 6904A and 6904B - double contact set NEWYORK 6904A</i>	
Contatto per operatore e porte FALCONI	3.15
<i>Contact for operator and door FALCONI</i>	
Contatto più ponte e staffe per sostituzione OTIS LM vecchia esecuzione	3.26
<i>Contact with more bridge and bracket for replacement OTIS LM old and execution</i>	
Contatto ponti e supporto automatismo FIAM S/2PO - A/2PO	3.20
<i>Contact bridge and automatic support FIAM S/2PO - A/2PO</i>	
Contatto porte automatiche IGV	3.12
<i>Automatic door contact IGV</i>	
Contatto porte automatiche SCHINDLER	3.19
<i>Automatic door contact SCHINDLER</i>	
Contatto porte automatiche SELCOM AS07	3.6
<i>Automatic door contact SELCOM AS07</i>	
Contatto porte CEAM	3.8
<i>Door contact CEAM</i>	

Contatto portine FIAM, SABIEM, KRONENBERG DZ73 con ponti h.18mm e h.21mm interasse 29mm e 49mm	3.27
<i>Door contact FIAM, SABIEM, KRONENBERG DZ73 with bridge h.18mm and h.21mm distance 29mm and 49mm</i>	
Contatto SCHLIEREN GK	3.25
<i>Contact SCHLIEREN GK</i>	
Contatto tipo K	3.7
<i>Contact type K</i>	
Contatti di qualità 53x75x22	3.5
<i>Contact of quality 53x75x22</i>	
Contatti di qualità 51x52x22	3.5
<i>Contact of quality 53x52x22</i>	
Contatti in coppia per vecchio FIAM A2PO	3.16
<i>Double contact for old FIAM A2PO</i>	
Interruttore a chiave estraibile con e senza cifratura	3.34
<i>Key switch extractable with or without key code</i>	
Interruttore a chiave KA con ritorno a molla estraibile con e senza cifratura	3.34
<i>Key switch KA with spring return extractable with or without key code</i>	
Microswitch a leva lunga FIAM C36ZP	3.33
<i>Microswitch with long lever FIAM C36ZP</i>	
Microswitch BASSETTI e STANDARD	3.32
<i>Microswitch BASSETTI and STANDARD</i>	
Microswitch STANDARD - FORSID	3.33
<i>Microswitch STANDARD - FORSID</i>	
Ponte B/2PO - B/2PT FIAM	3.21
<i>Bridge B/2PO - B/2PT FIAM</i>	
Ponte contatto OTIS LM tipo vecchio	3.27
<i>Bridge contact OTIS LM type old</i>	

Ponte forcella KRONENBERG	3.25
<i>Actuator bridge KRONENBERG</i>	
Ponte OTIS lungo e corto contatto SCHLIEREN TVC contatto serratura stagna FIAM contatto LLW OTIS	3.23
<i>OTIS short and long bridge contact SCHLIEREN, TVC cabin door contact FIAM contact LLW OTIS</i>	
Ponti h18 mm e h 21 mm interesse 29 mm e 49 mm KRONENBERG	3.13- 3.24
<i>Bridge h18mm and h21mm distance 29mm and 49 mm KRONENBERG</i>	
Ponti OTIS contatto ORLY OTIS - NEW YORK 6940A - ORLY F099 - NEW YORK 6940B	3.18
<i>OTIS bridge ORLY OTIS contact - NEW YORK 6940A - ORLY F099 - NEW YORK 6940B</i>	
Ponti contatti operatori	3.5
<i>Door operator contact bridge</i>	
Ponte contatto A/2PO FIAM.....	3.16
<i>FIAM A/2PO contact bridge</i>	
Ponte di contatto S/2PO - S/4PT FIAM	3.22
<i>FIAM S/2PO - S/4PT contact bridge</i>	
Ponte di contatto serratura FIAM	3.22
<i>FIAM door lock contact bridge</i>	

Note: I componenti sul catalogo con riportata una specifica marca di ascensore sono utilizzati abitualmente solo da questa marca. I particolari senza marca sono utilizzati da più marche di ascensori.

Note: The components in the catalogue with a specific lift brand are usually used only by the brand. Unbranded parts are used by multiple lift brands.

CONTATTI OPERATORI OPERATORS CONTACTS

3



Contatti operatori, porte battente porte a ghigliottina, cancelli, portine cabina in esecuzione stagna ed antideflagrante

Operators contacts for swing doors, guillotine door, gates, waterproof and expulsion proof execution in cabin door

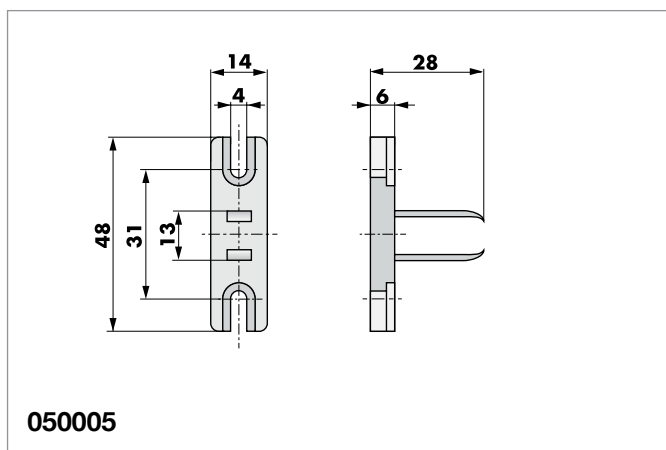
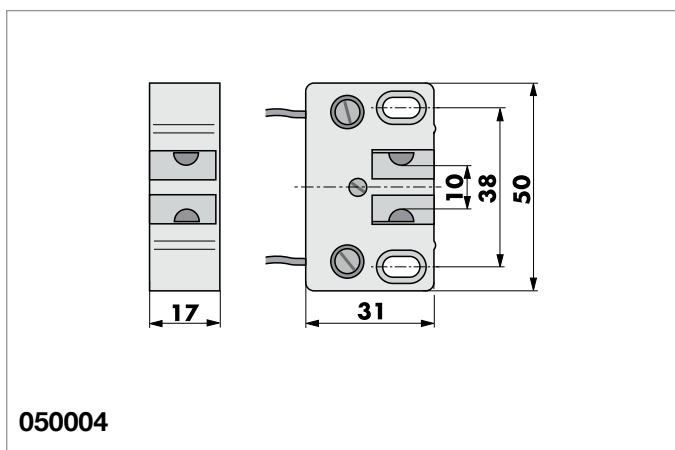

Codice / Code	Descrizione
050004	Contatto installabile anche su operatori BASSETTI - FORSID-KAMER
050005	Ponte per codice 050004

CONTATTO PORTE AUTOMATICHE DAPA AUTOMATIC DOOR CONTACT FOR DAPA

3



14057/A



14057/B



14057/C



14057/D

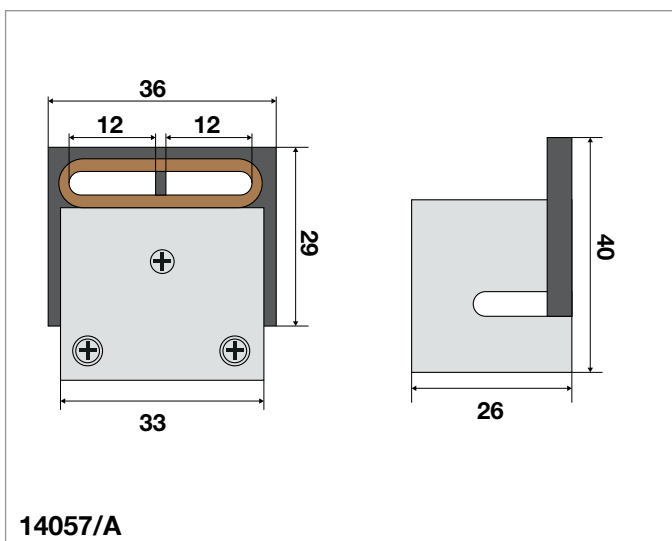

14057/A

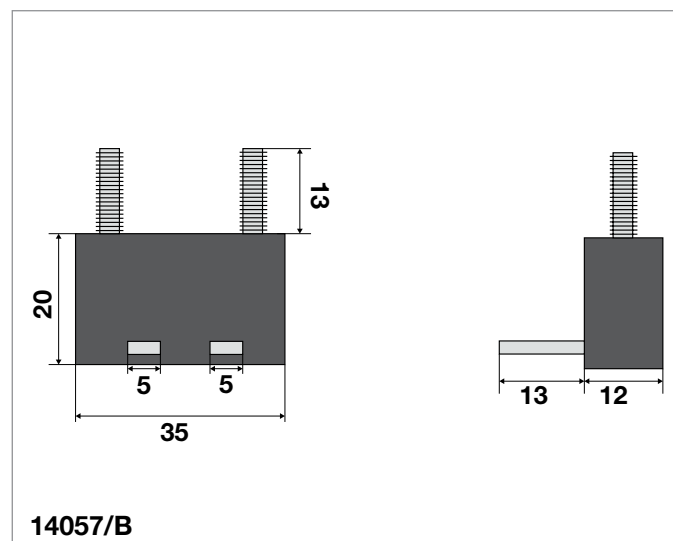

14057/B

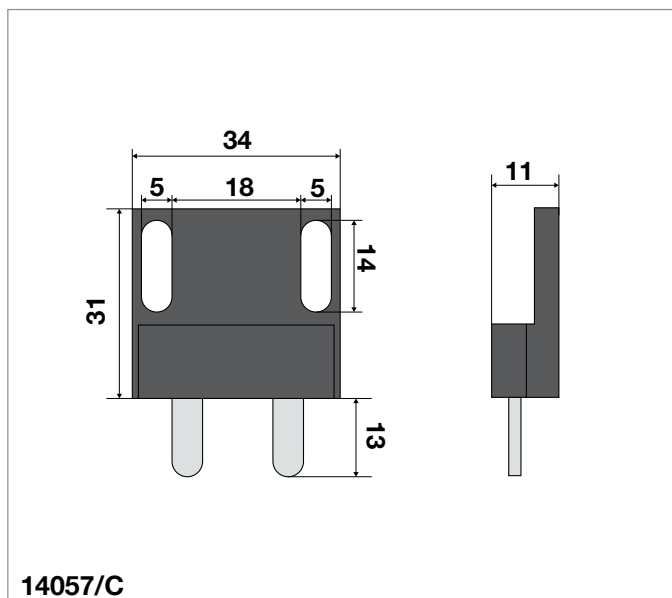

14057/C

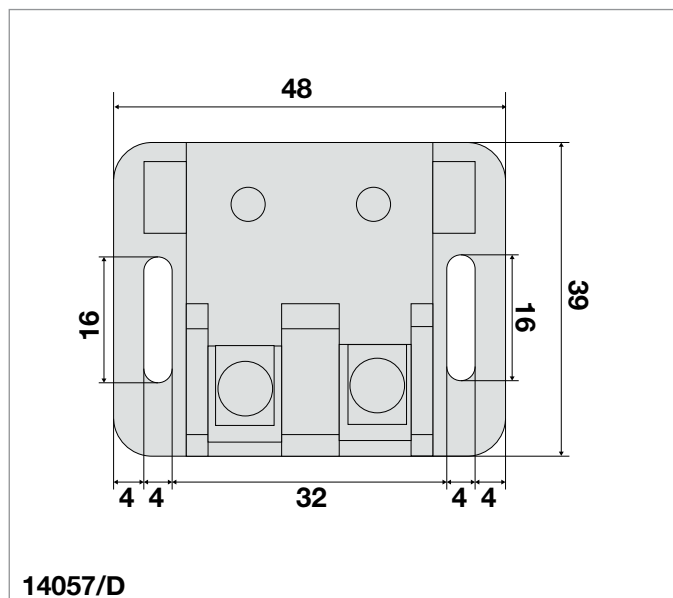

14057/D

Codice / Code	Descrizione
14057/A	Contatto parte femmina sospensione e operatore tipo vecchio (Dapa MEL081)
14057/B	Contatto parte maschio sospensione porte tipo vecchio (Dapa MEL082)
14057/C	Contatto parte maschio operatore porte tipo vecchio (Dapa MEL083)
14057/D	Contatto AS07 per porte automatiche SELCOM

CONTATTO TIPO K ENTRATA DAL FRONTE
FRONTAL ENTRY CONTACT TYPE K

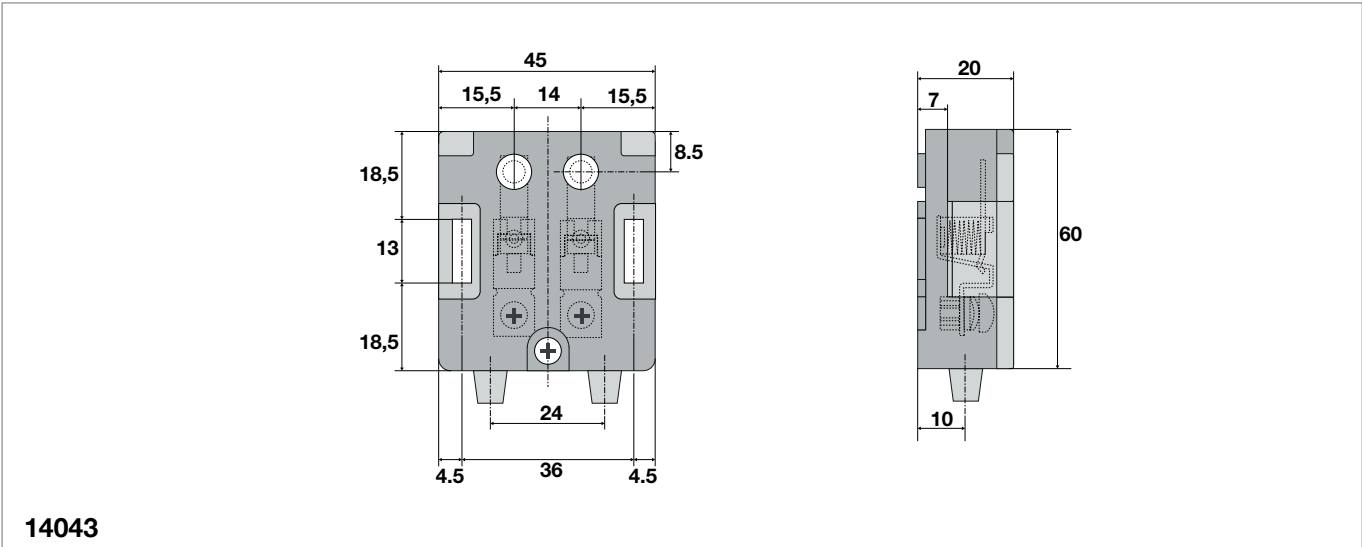
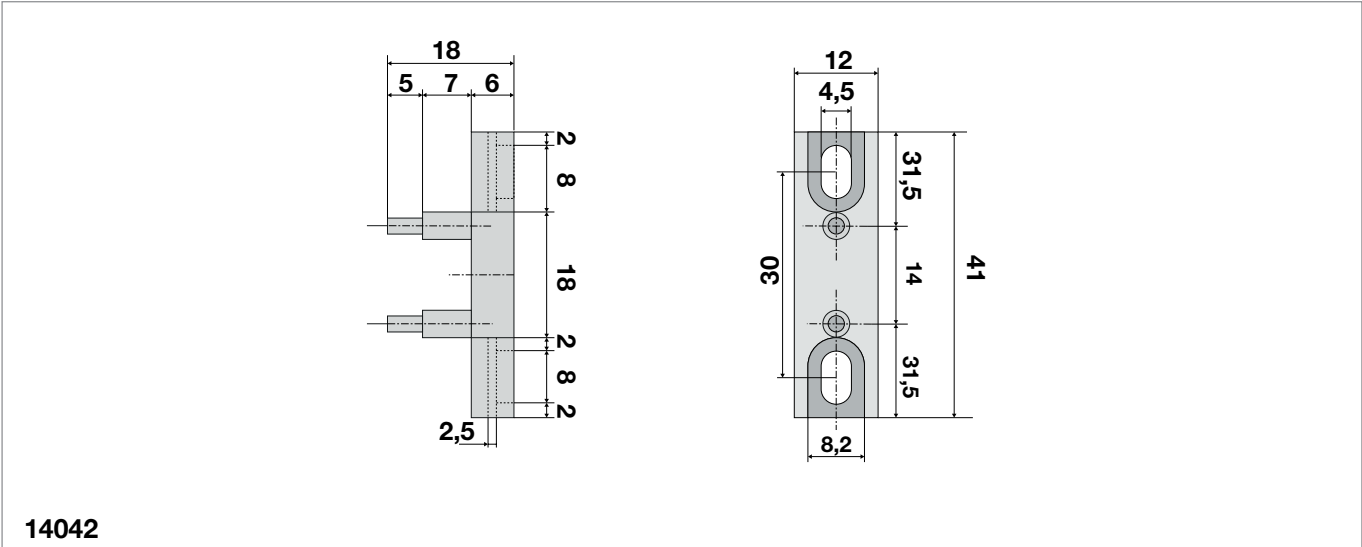
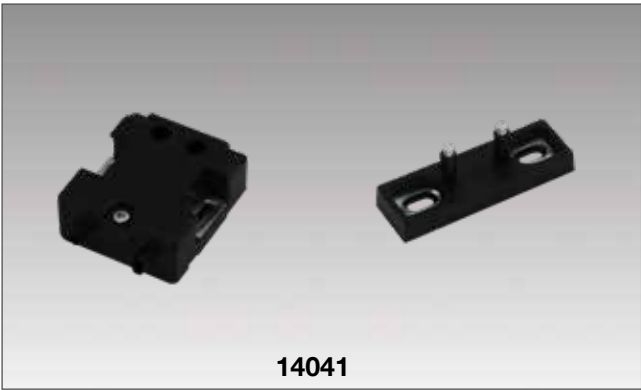

Note: si può invertire l'entrata del ponte del contatto dal fronte al retro

Note: the contact bridge entry can be reversed from front to back

Codice / Code	Descrizione
14041	Contatto completo (cod.14042 + 14043)
14042	Solo ponte
14043	Solo corpo

CONTATTO PORTE AUTOMATICHE CEAM AUTOMATICS DOOR CONTACT FOR CEAM

3

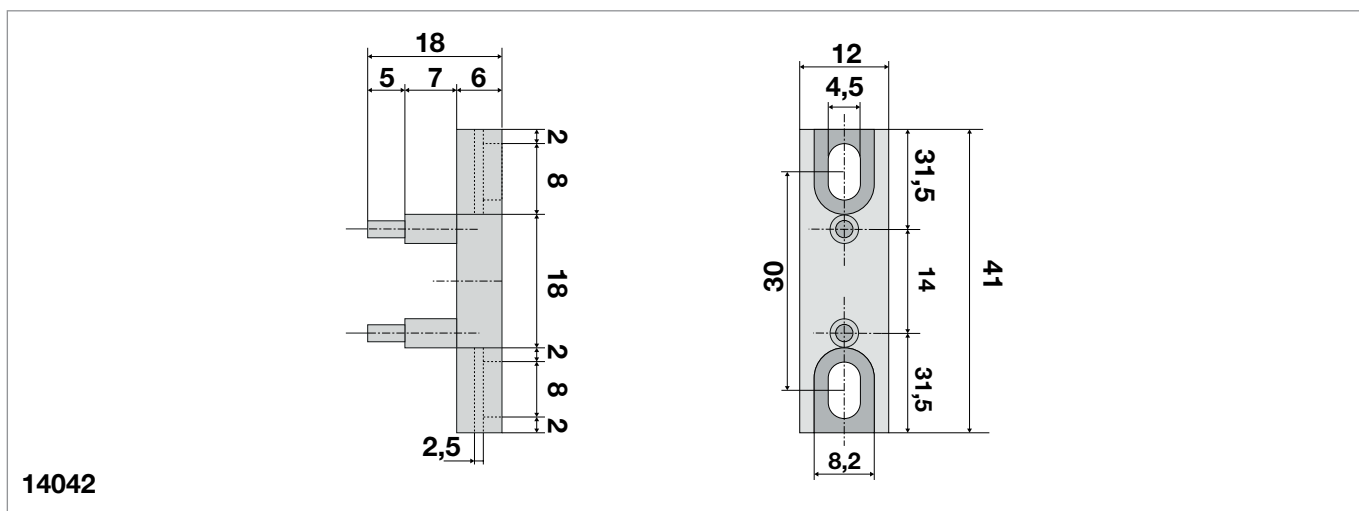
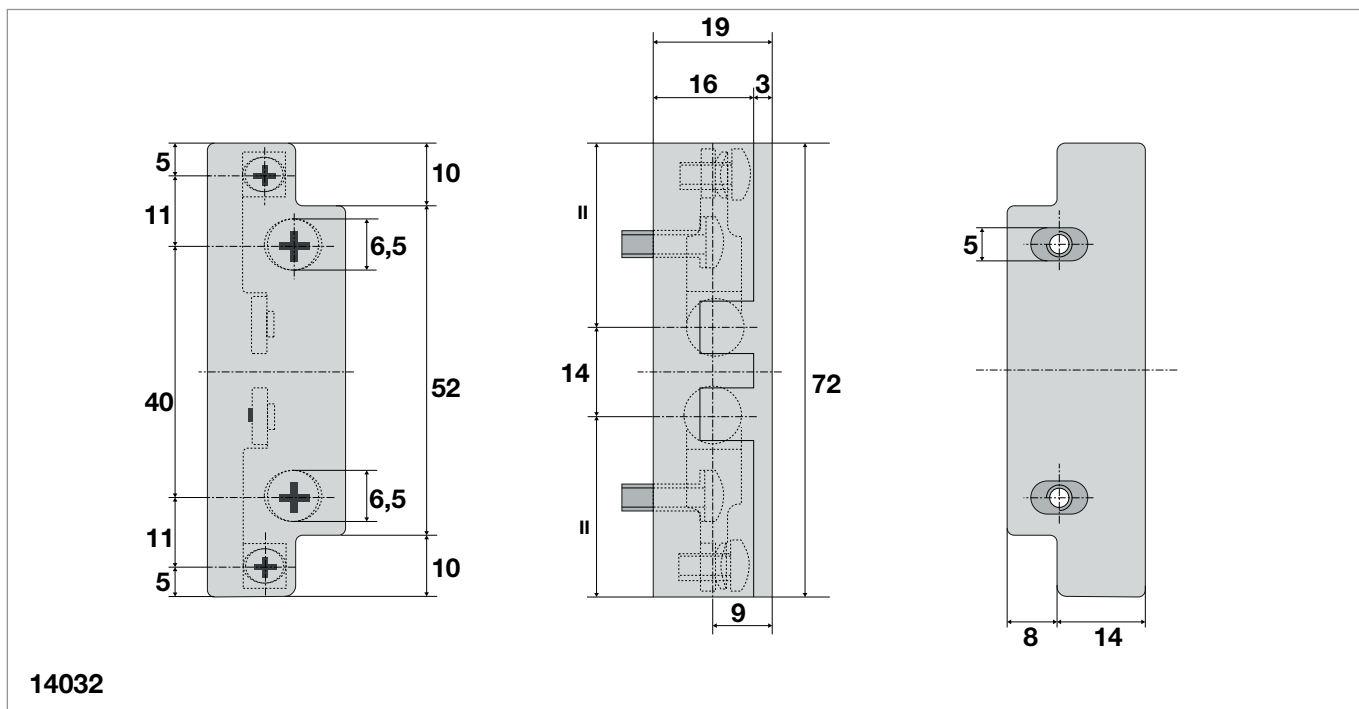

Codice / Code	Descrizione
14032	Contatto porte Automatiche Ceam
14042	Ponte

CONTATTO A STRISCIO BASSETTI - IGV
SCROLL CONTACT FOR BASSETTI - IGV

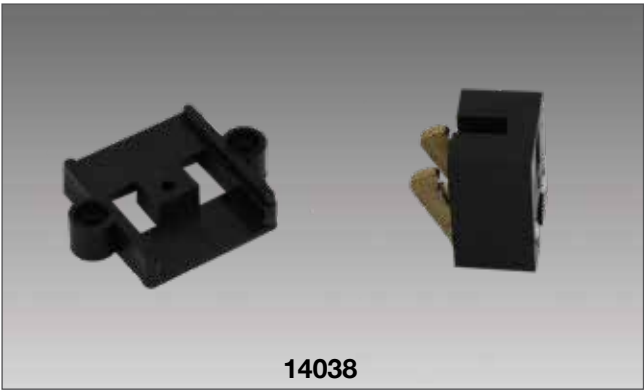

14038

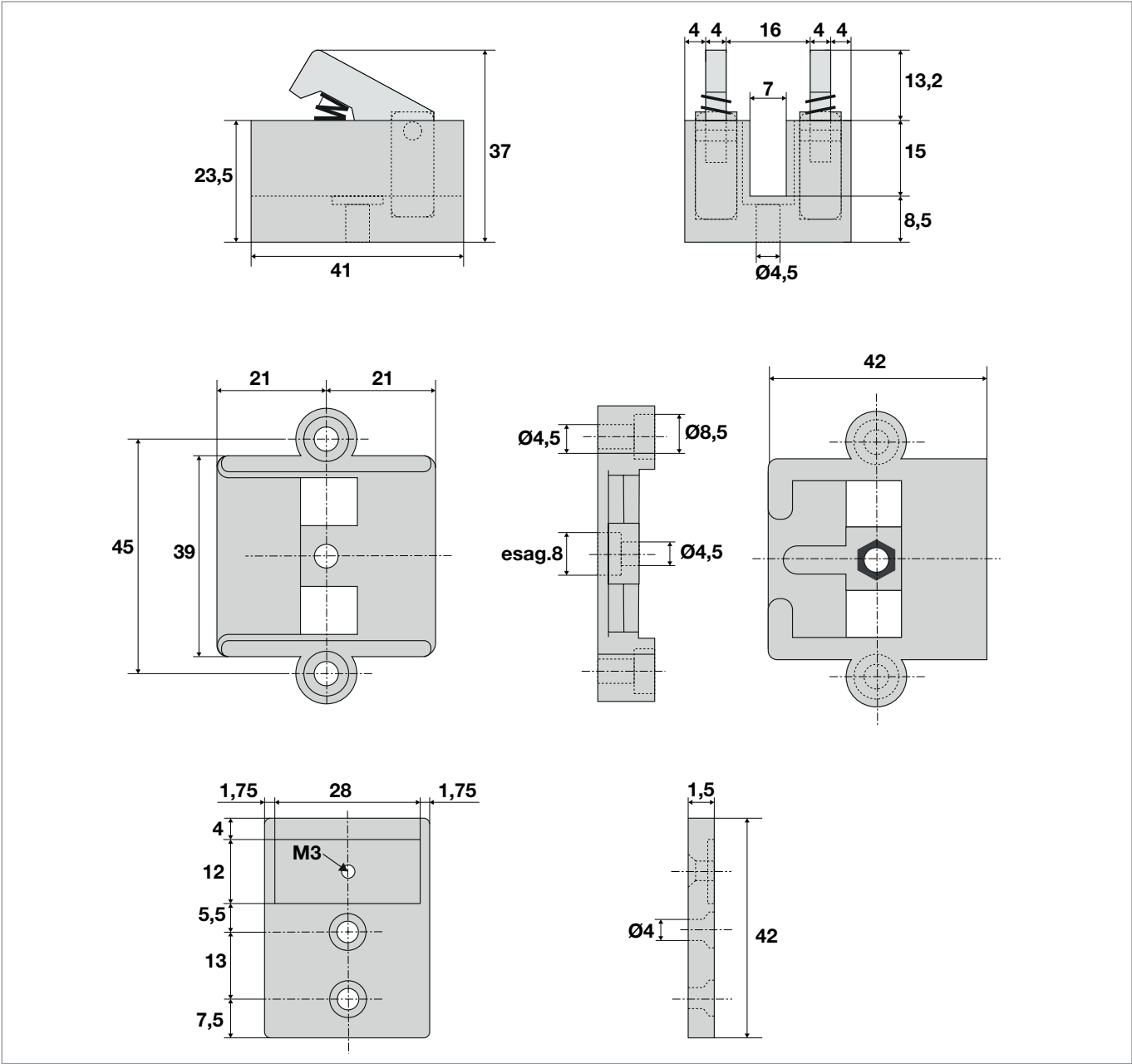

Codice / Code	Descrizione
14038	Contatto a striscio completo BASSETTI - IGV

CONTATTO A DOPPIO SPILLO COMPLETO IGV COMPLETE DOUBLE PIN CONTACT IGV

3

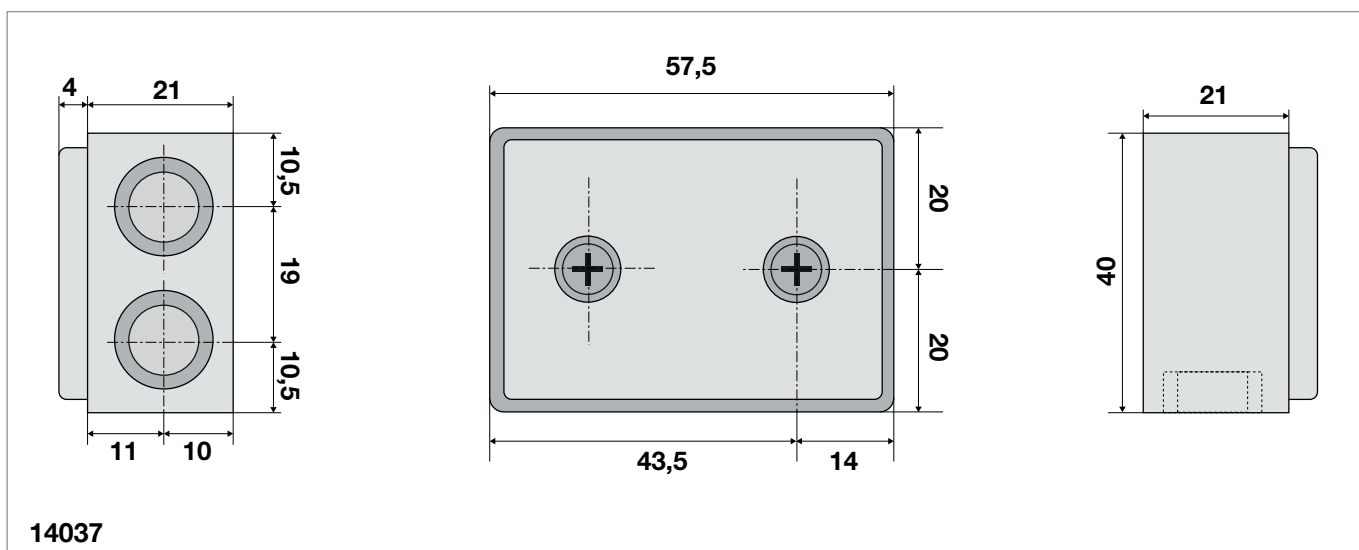
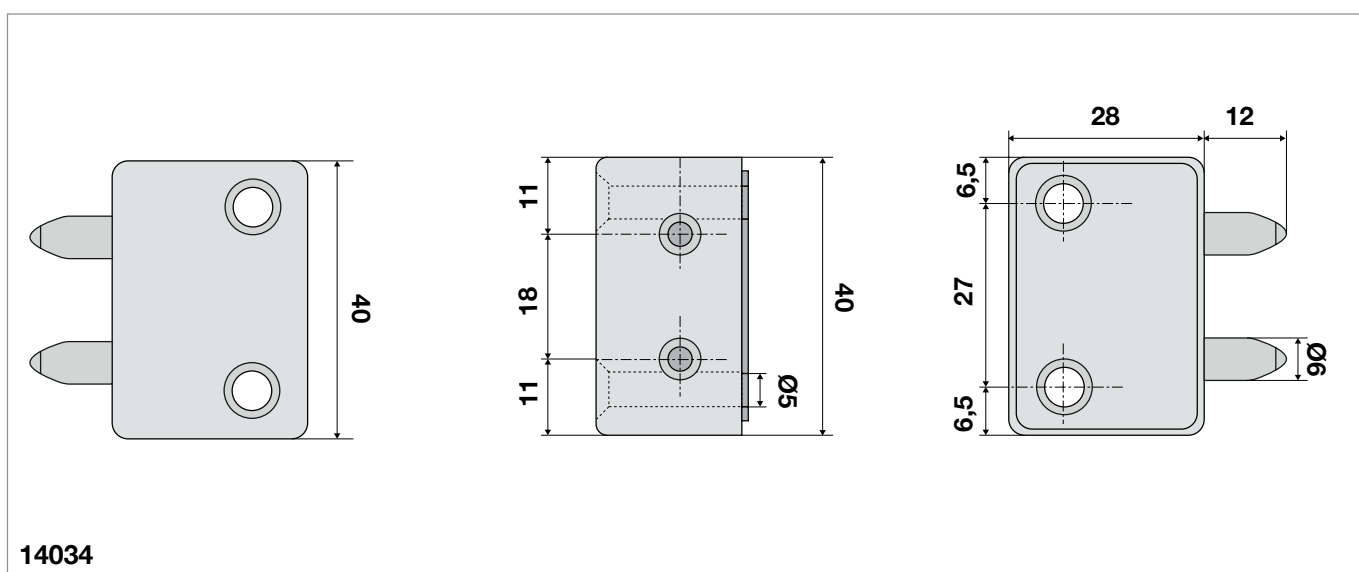
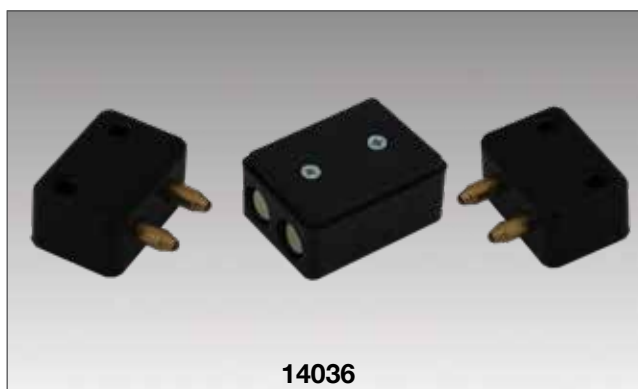

Codice / Code	Descrizione
14034	Ponte
14036	Contatto doppio spillo completo
14037	Solo corpo

**CONTATTO A SPILLO SEMPLICE IGV
COMPLETE SIMPLE PIN CONTACT IGV**

3

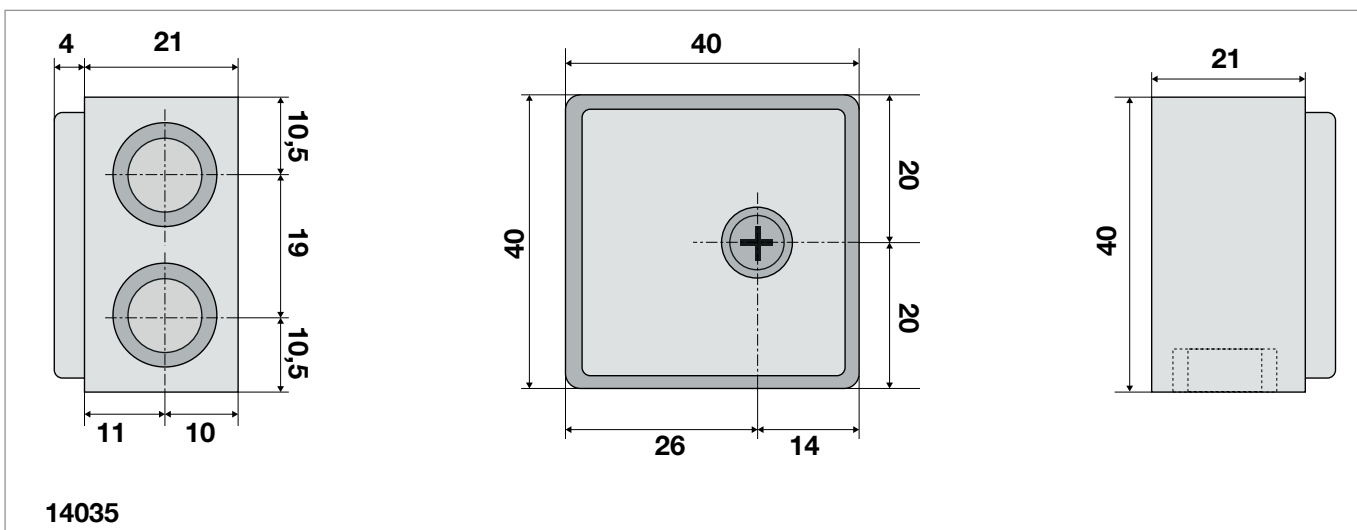
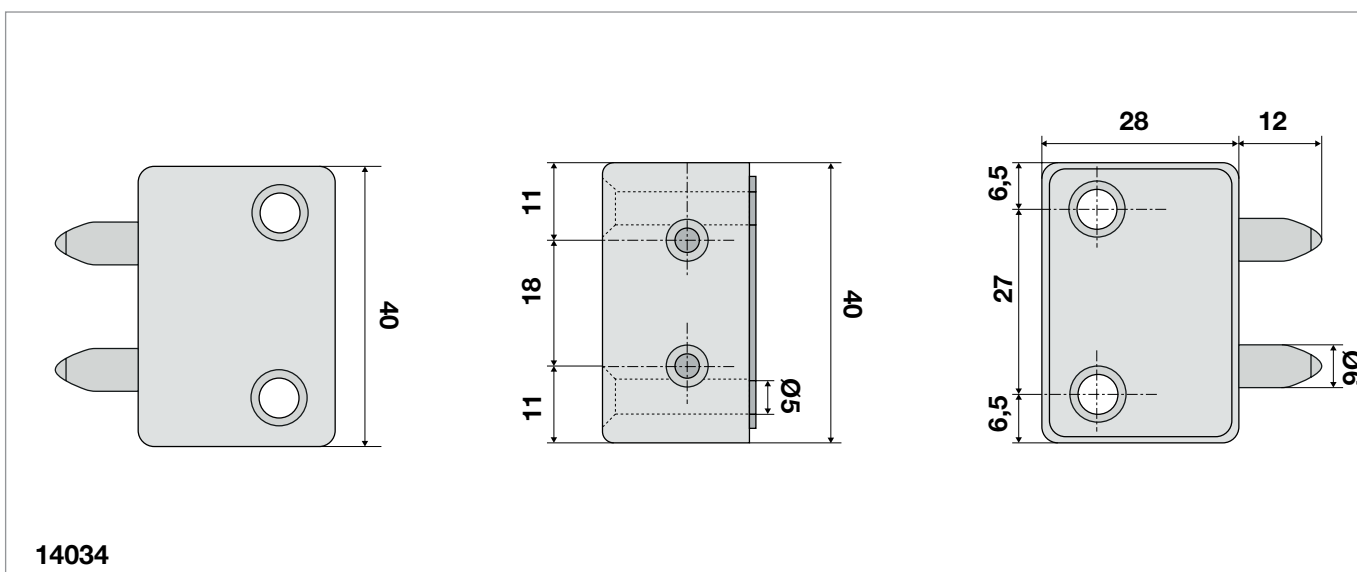
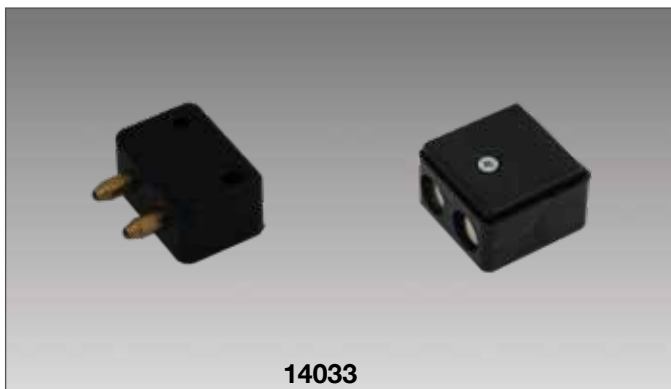

Codice / Code	Descrizione
14033	Contatto a spillo semplice completo
14034	Ponte
14035	Solo corpo

CONTATTO PER PORTE AUTOMATICHE IGV
CONTACT FOR AUTOMATIC DOORS IGV

3

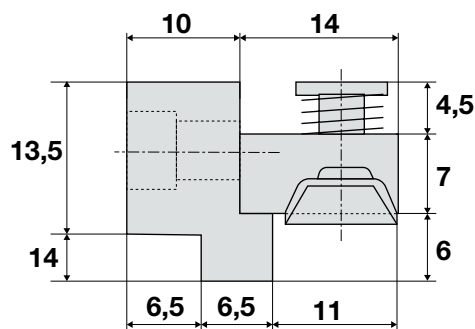
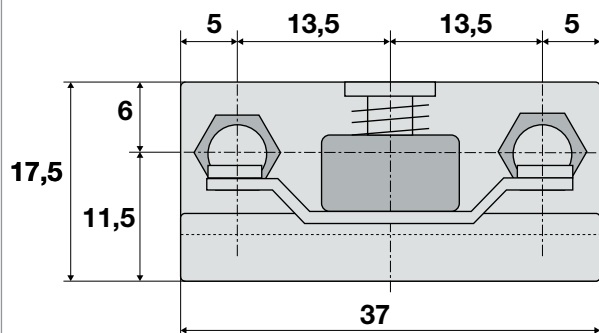
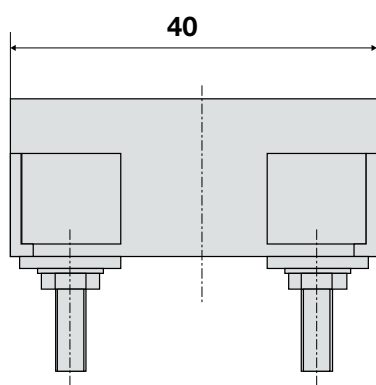
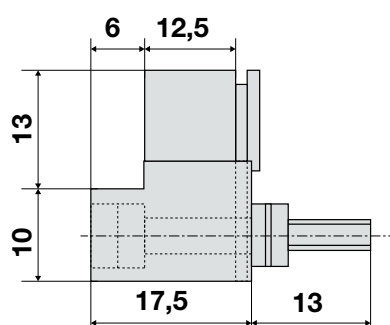
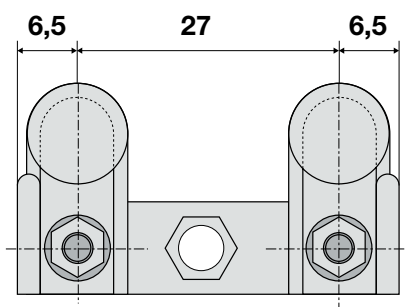
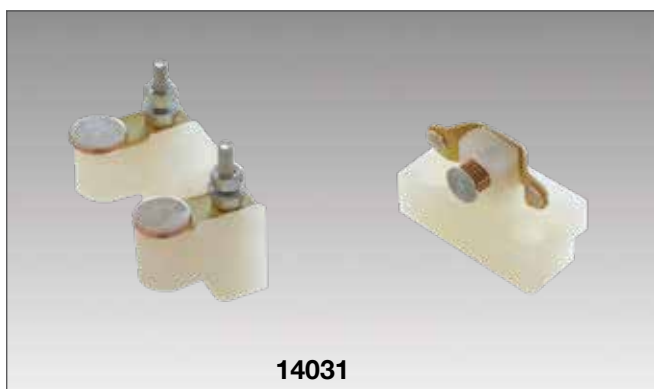

Codice / Code	Descrizione
14031	Contatto per porte automatiche IGV

CONTATTO KRONENBERG HZ A SQUADRETTA KRONENBERG HZ SQUARE CONTACT

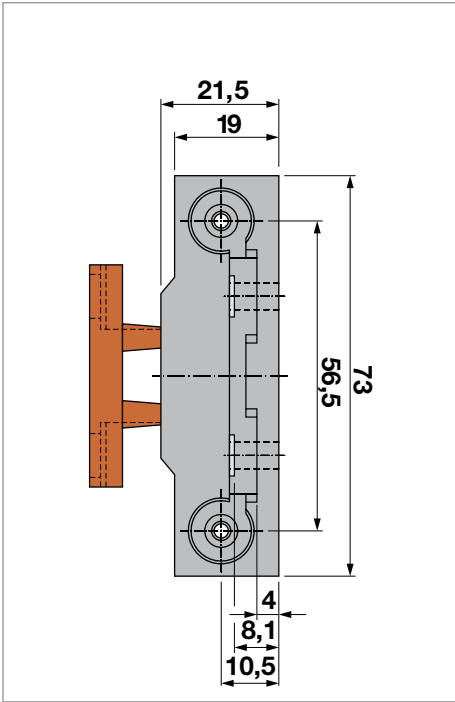
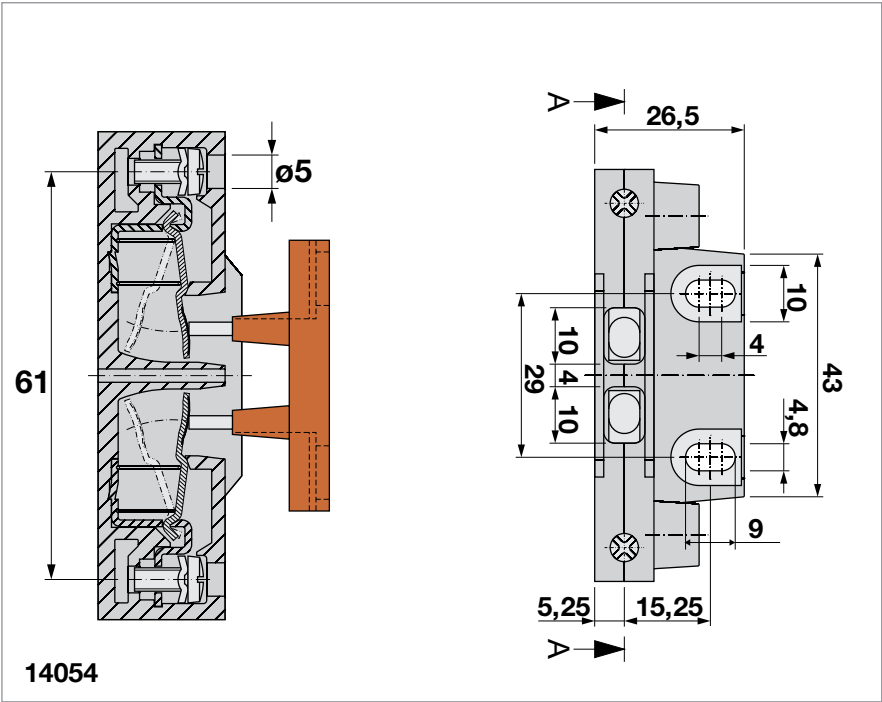
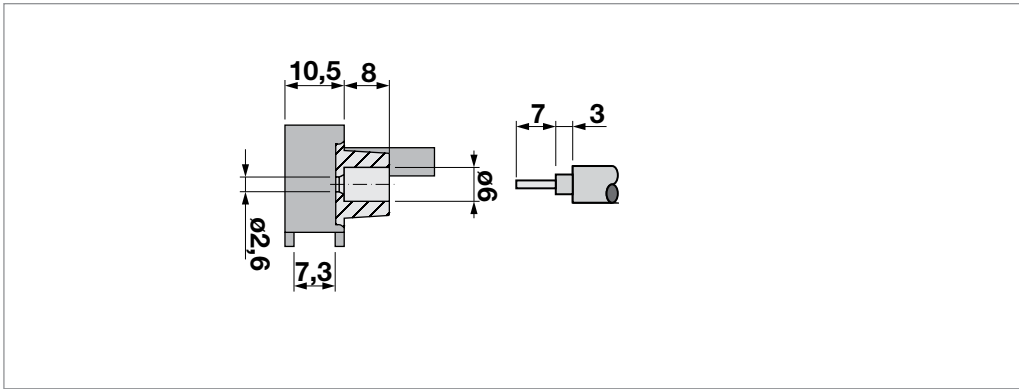

Codice / Code	Descrizione
14042	Ponte non originale h.18 interasse fori 29 mm
14042/1	Ponte KRONENBERG h.18 interasse fori 29 mm
14054	Contatto KRONENBERG HZ a squadretta
14055	Ponte KRONENBERG h.21 interasse fori 29 mm
14056	Ponte KRONENBERG h.18 interasse fori 49 mm
14057	Ponte KRONENBERG h.21 interasse fori 49 mm

CONTATTO A PISTONCINI PER AUTOMATISIMO "S" FIAM
LITTLE PISTON CONTACT FOR AUTOMATIC DOOR FIAM TYPE "S"

3

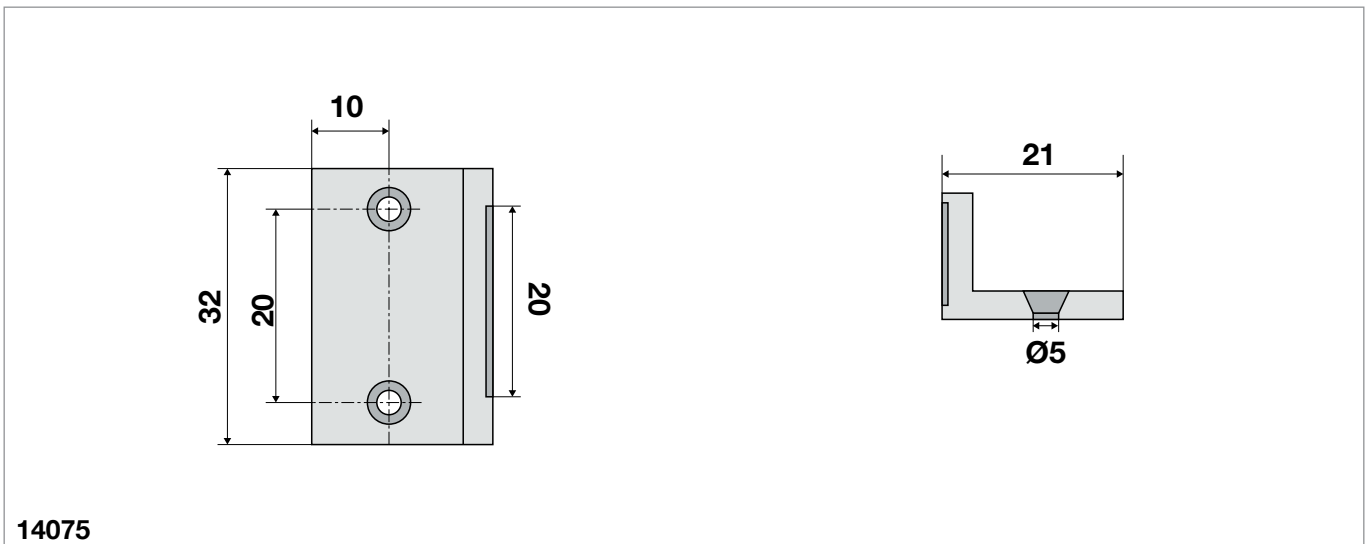
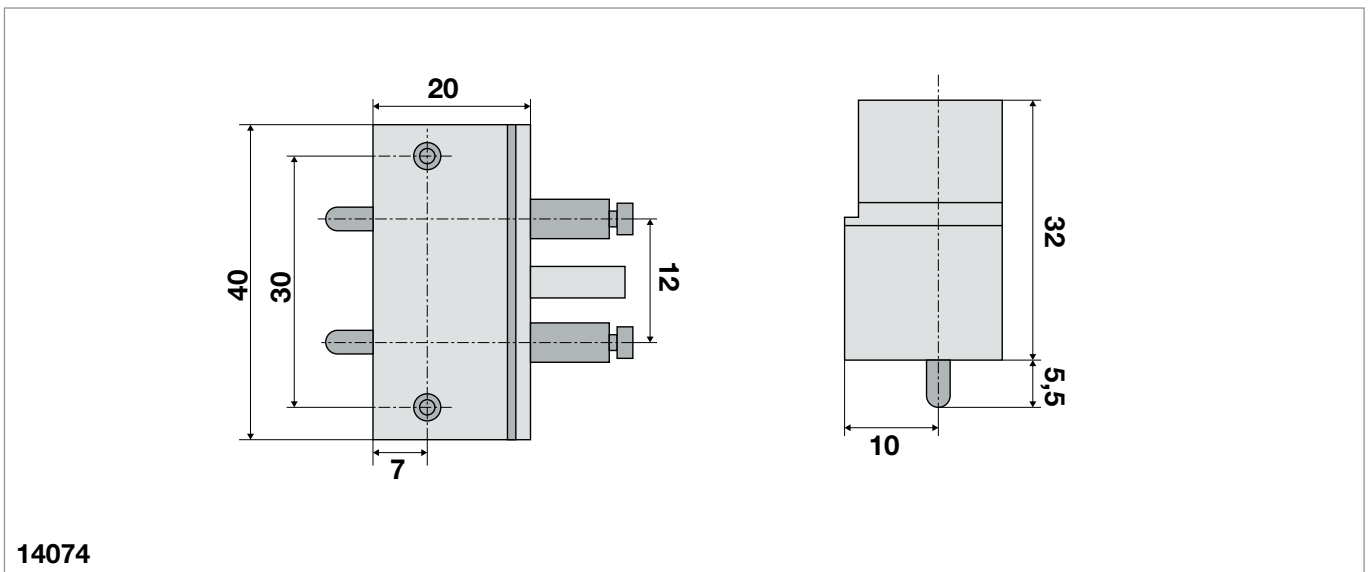

Codice / Code	Descrizione
14074	Maschio contatto operatore S/2PO FIAM
14075	Femmina contatto operatore S/2PO FIAM

CONTATTO A PONTE COMPLETO FALCONI
COMPLETE BRIDGE AND CONTACT FALCONI



14071

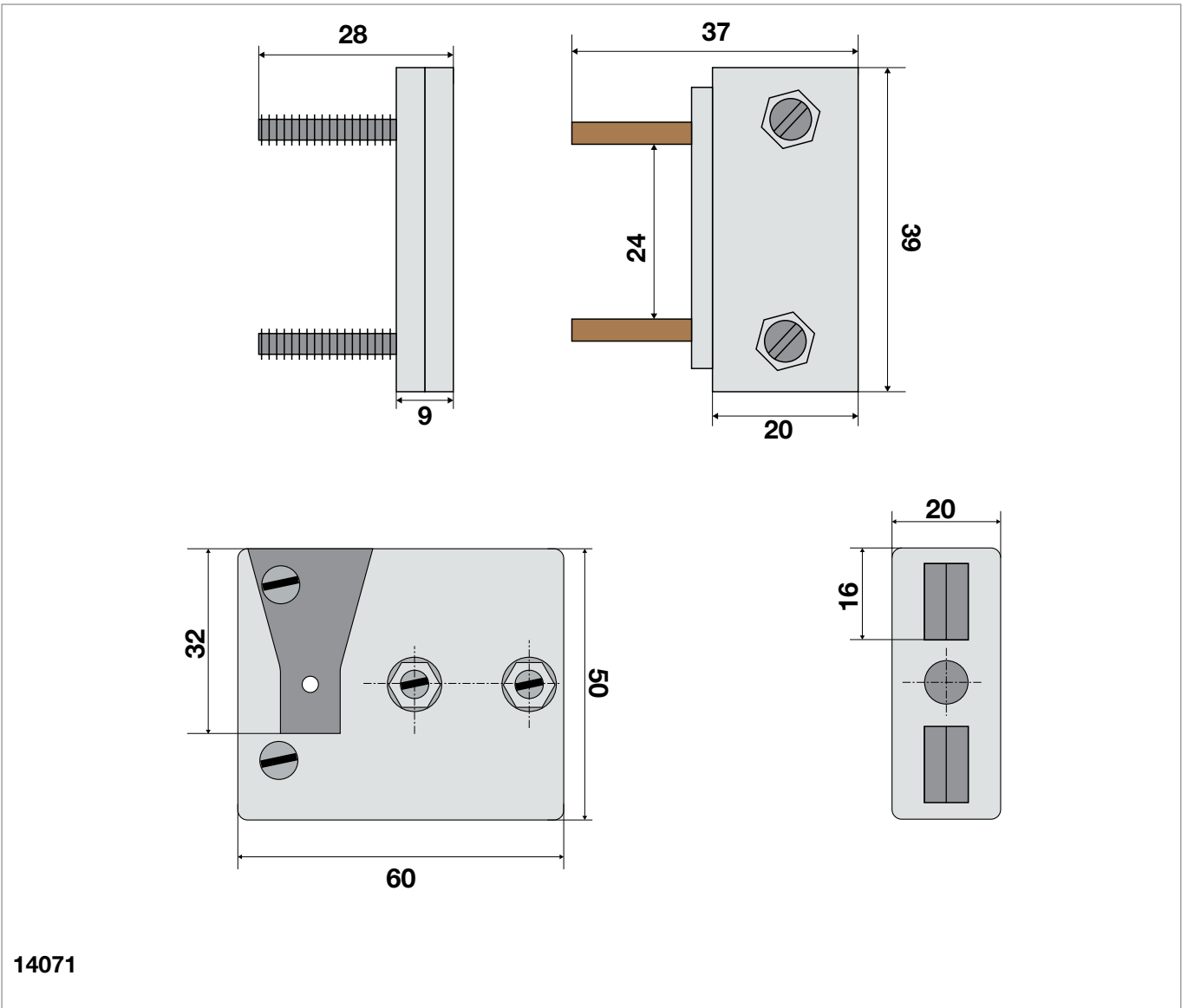

14071

Codice / Code	Descrizione
14071	Contatto a ponte completo per serratura e operatore FALCONI

CONTATTO A /2PO COMPLETO DI PONTI TIPO VECCHIO FIAM
A/2PO CONTACT WITH COMPLETE BRIDGE TYPE OLD FIAM

3

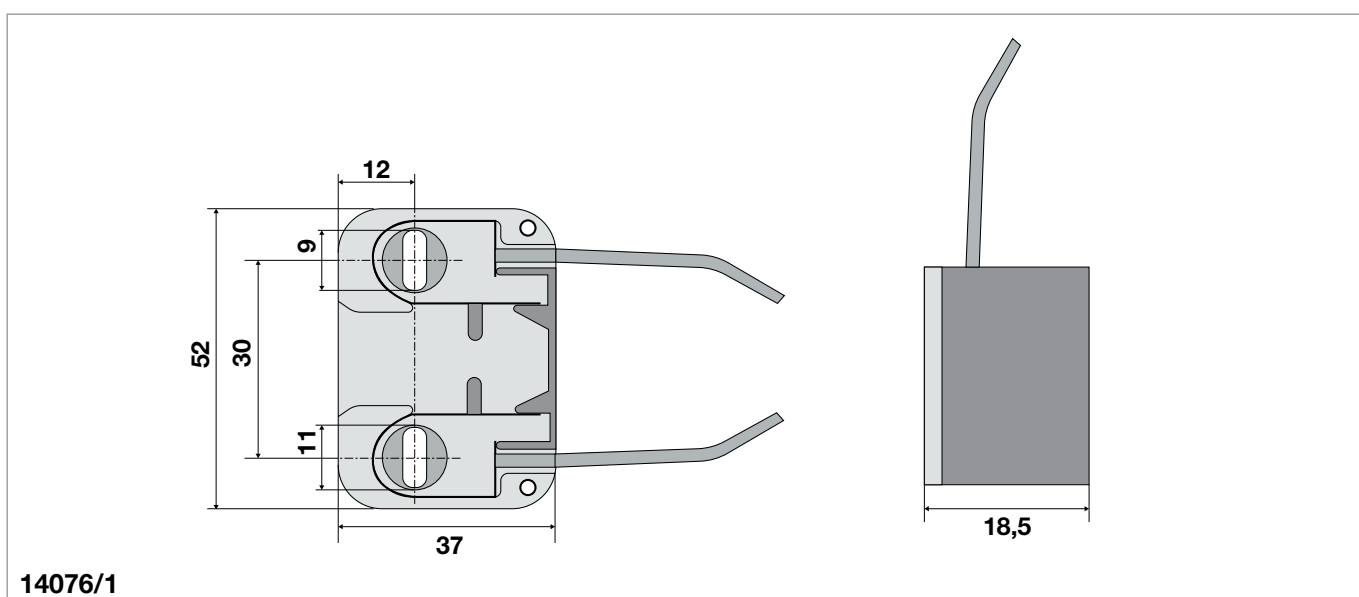
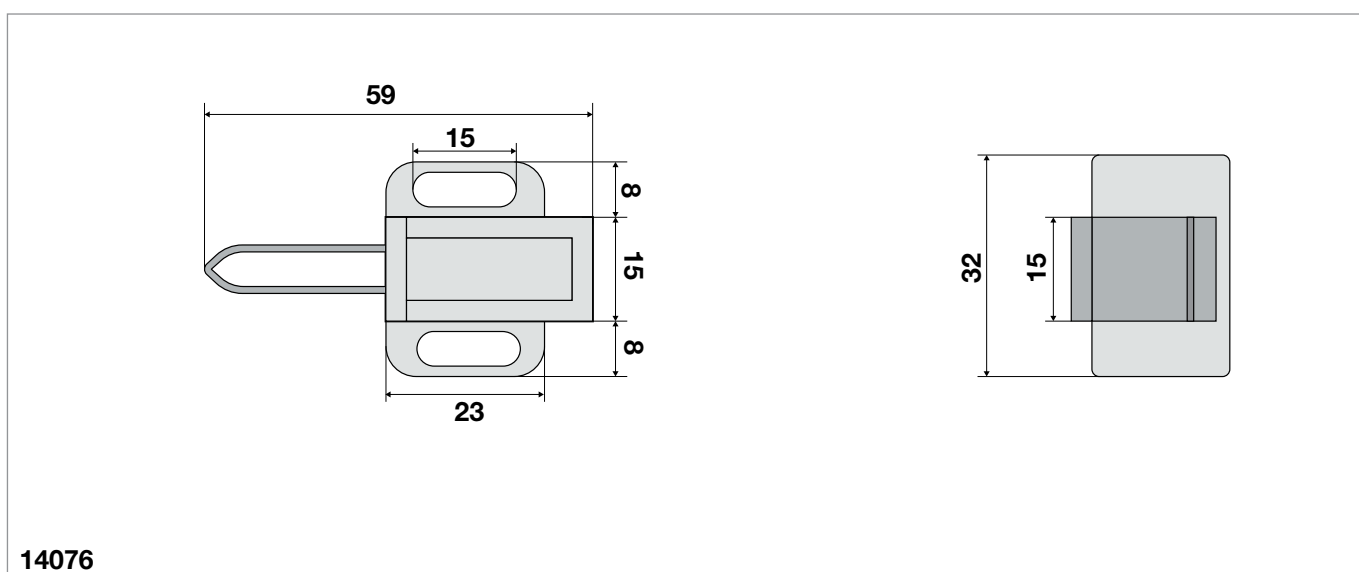

Codice / Code	Descrizione
14076	Ponte A/2PO tipo vecchio FIAM
14076/1	Contatto A/2PO tipo vecchio FIAM
14077	Contatto A/2PO completo di ponti tipo vecchio FIAM

CONTATTI OTIS CONTACT OTIS

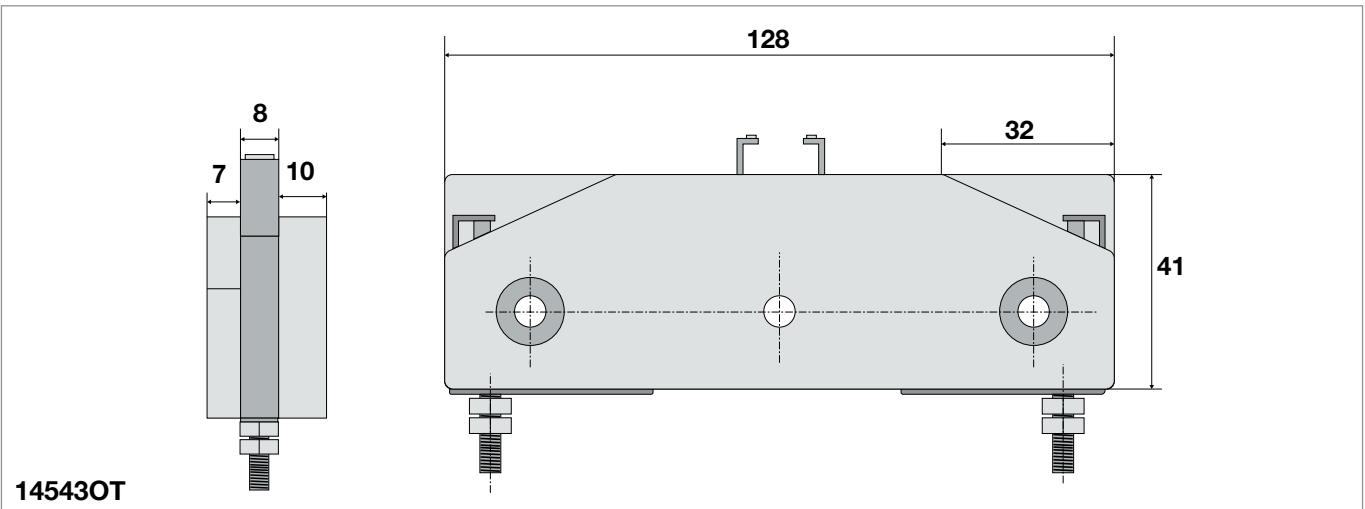
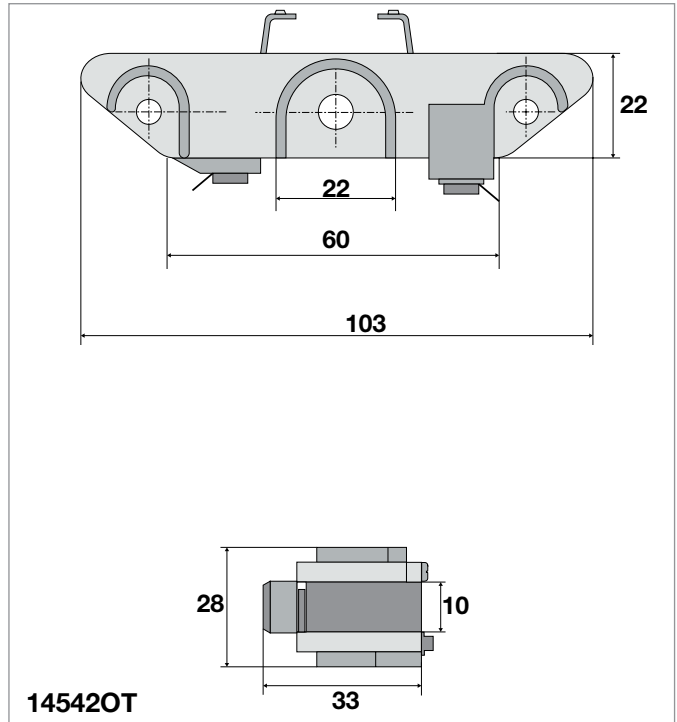
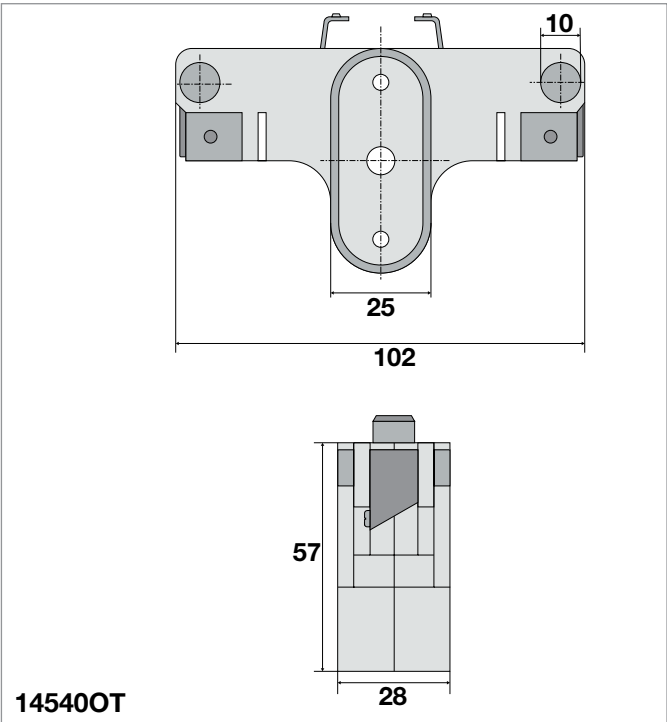

Codice / Code	Descrizione
145400T	Contatto New York 6940A OTIS
145420T	Contatto Orly F09940B OTIS
145430T	Contatto New York 6940B OTIS

PONTE PER CONTATTI OTIS BRIDGE FOR OTIS CONTACT

3

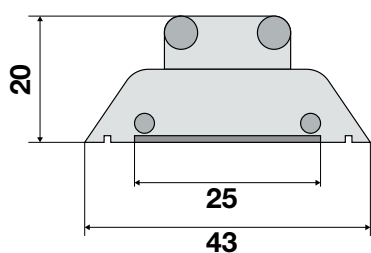
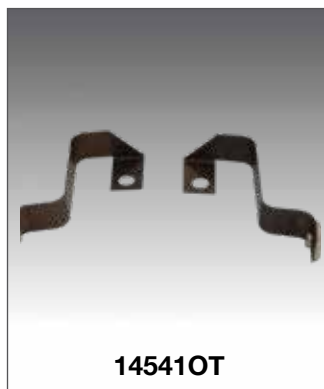

14538OT

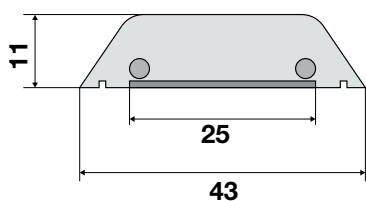
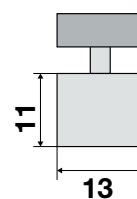

14539OT

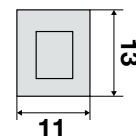

Coppia di lamelle

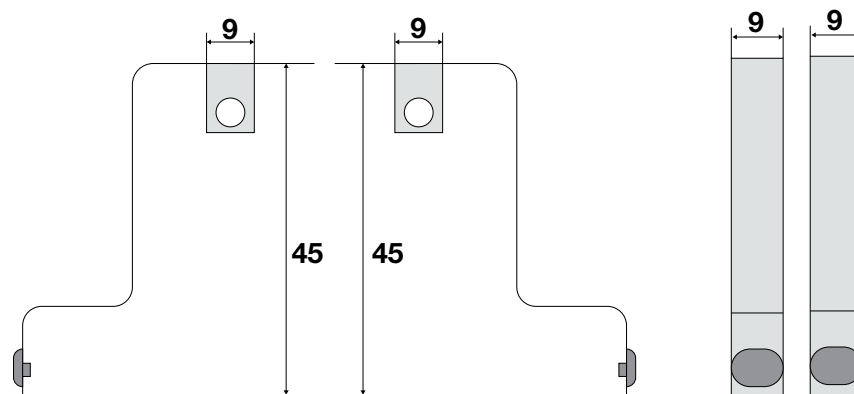

14541OT

Codice / Code	Descrizione
14538OT	Ponte contatto ORLY OTIS
14539OT	Ponte contatto New York 6940A OTIS e 6940B
14541OT	Coppia di lamelle per contatto New York 6940A OTIS

CONTATTO PORTE AUTOMATICHE SCHINDLER SCHINDLER AUTOMATIC DOOR CONTACT

3

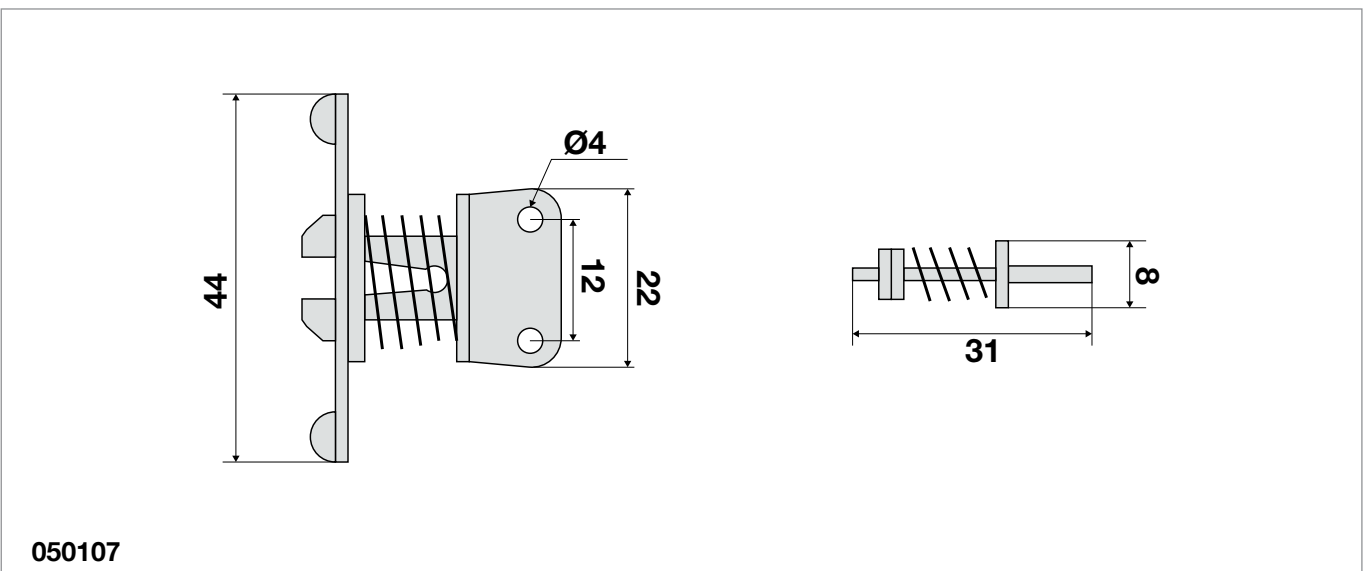
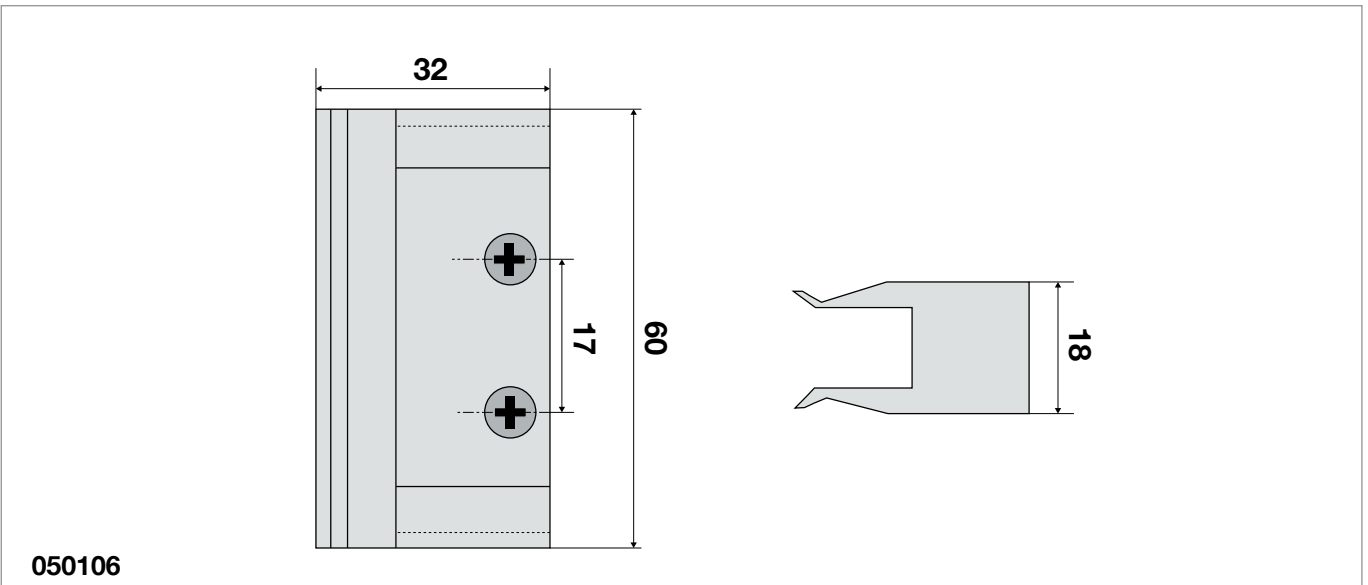

Codice / Code	Descrizione
050106	Corpo a prova di dito + protezione contatto porta automatica SCHINDLER
050107	Ponte contatto SCHINDLER

PONTE DI CONTATTO BRIDGE FOR CONTACT

3

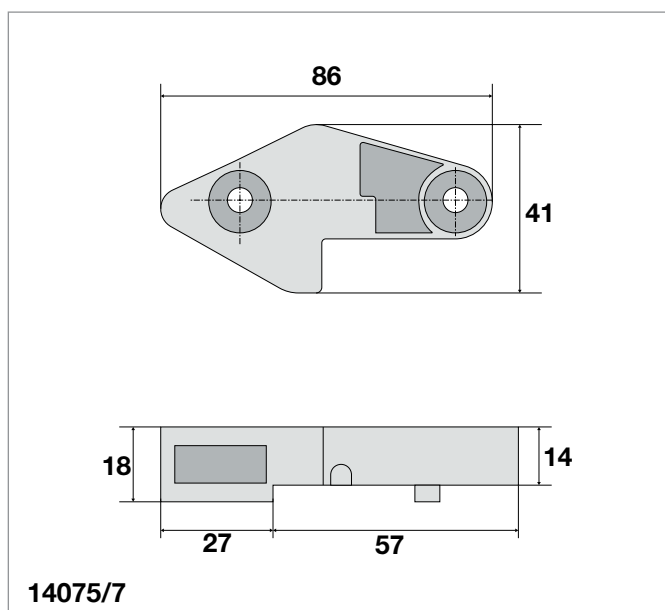
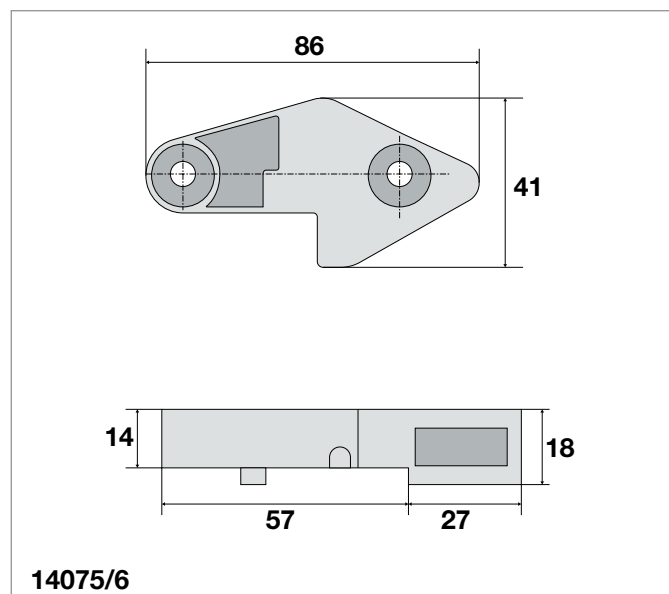
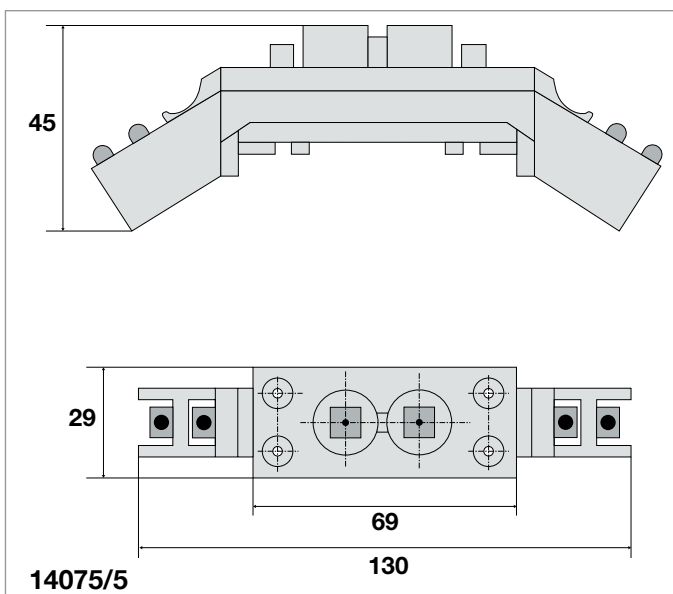

Codice / Code	Descrizione
14075/5	Ponte di contatto automatismo A/2PO FIAM
14075/6	Supporto ponte contatto automatismo A/2PO FIAM SX
14075/7	Supporto ponte contatto automatismo A/2PO FIAM DX

PONTE DI CONTATTO BRIDGE FOR CONTACT

3

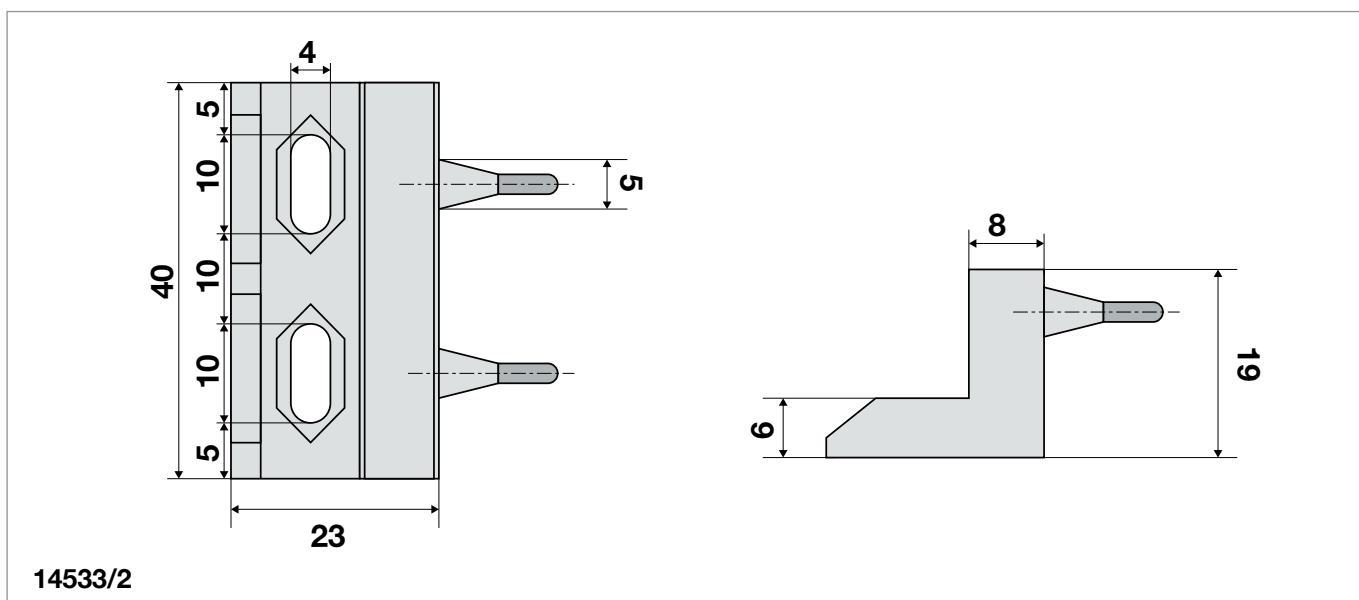
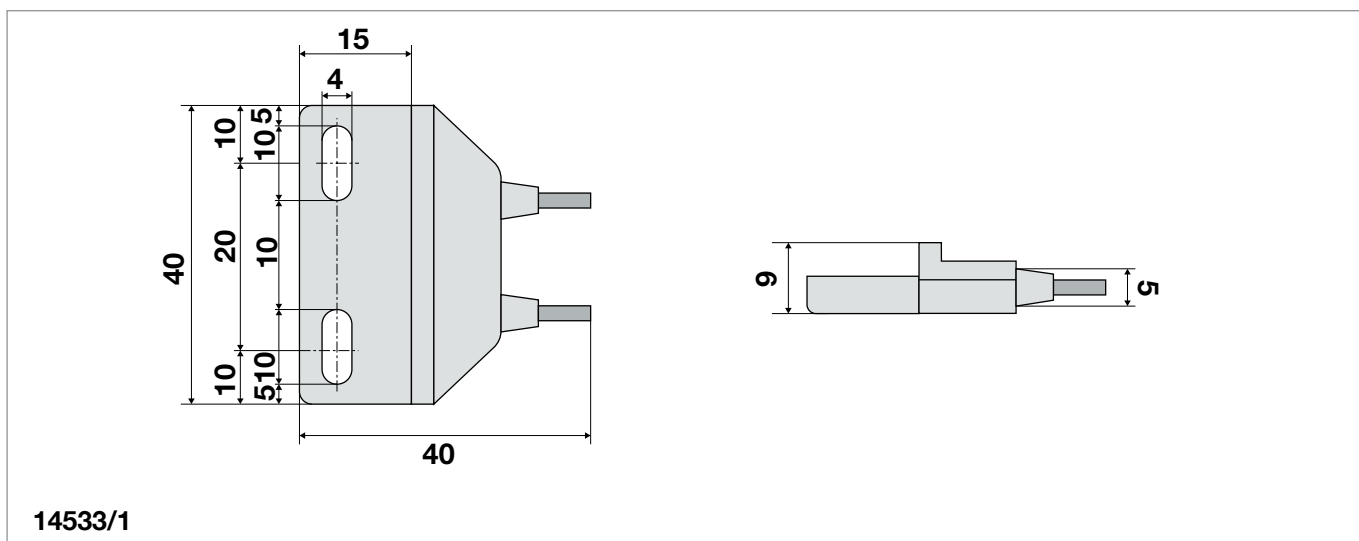
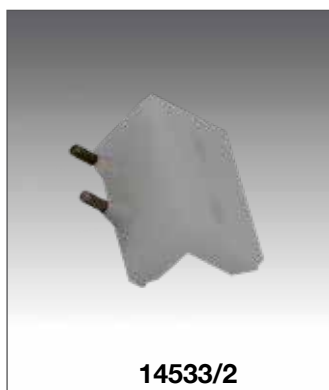

Codice / Code	Descrizione
14533/1	Ponte asportabile sospensione B/2PO FIAM
14533/2	Ponte asportabile B/2PT FIAM

PONTE DI CONTATTO BRIDGE FOR CONTACT

3

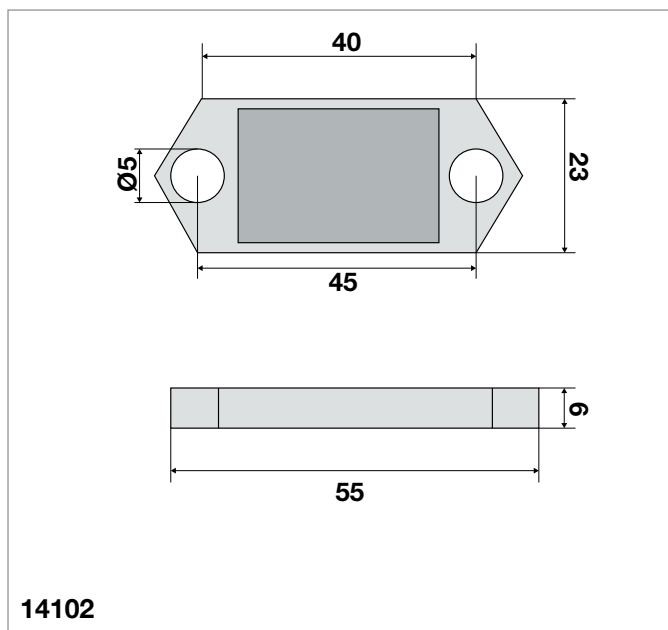
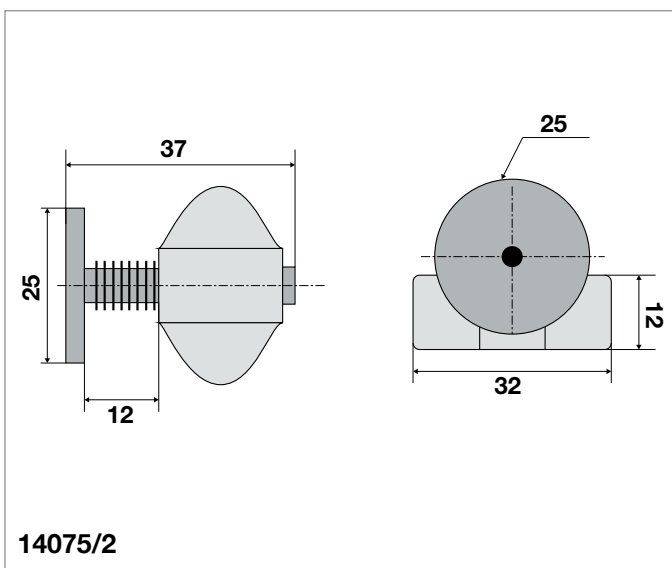
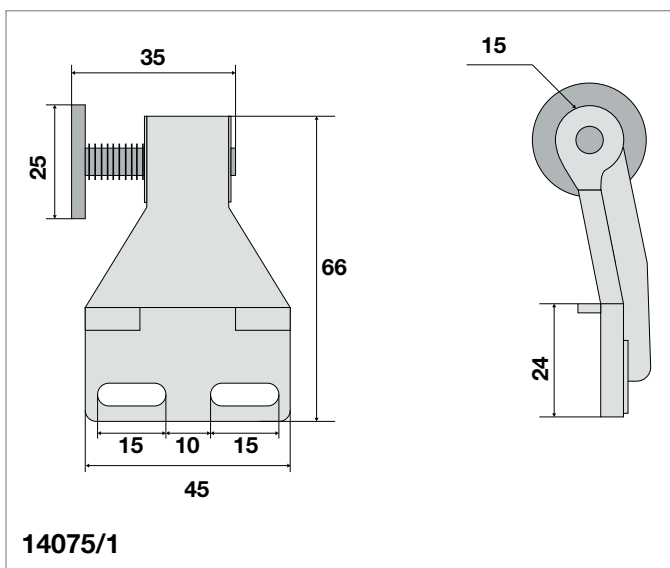
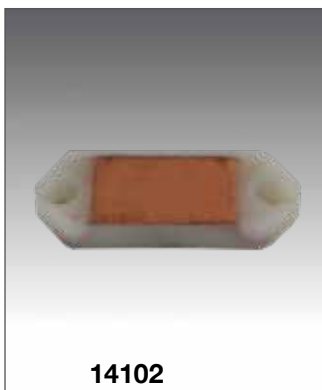

Codice / Code	Descrizione
14075/1	Ponte di contatto automatismo S/2PO FIAM
14075/2	Ponte di contatto automatismo S/4PT FIAM
14102	Ponte di contatto serratura FIAM per cancelli a ghigliottina

CONTATTO CONTACT

3

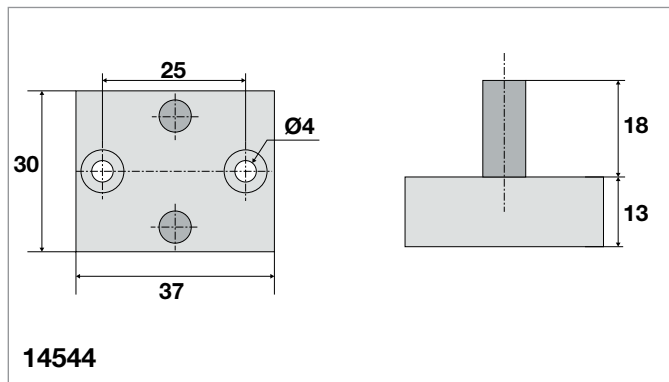
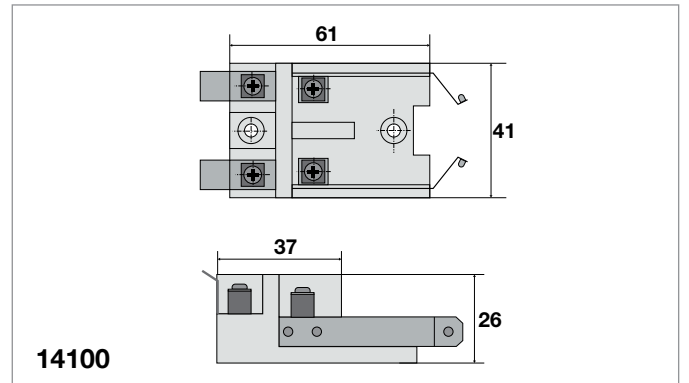
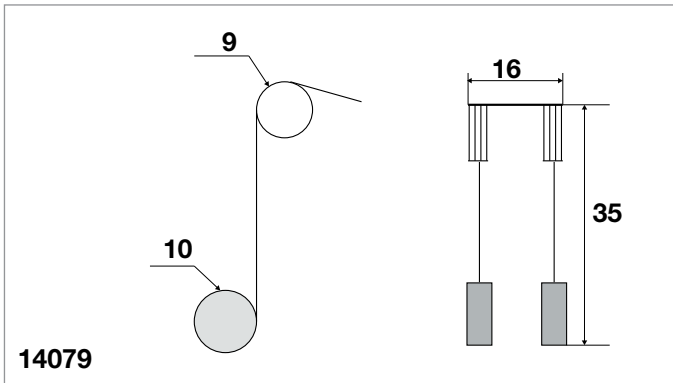
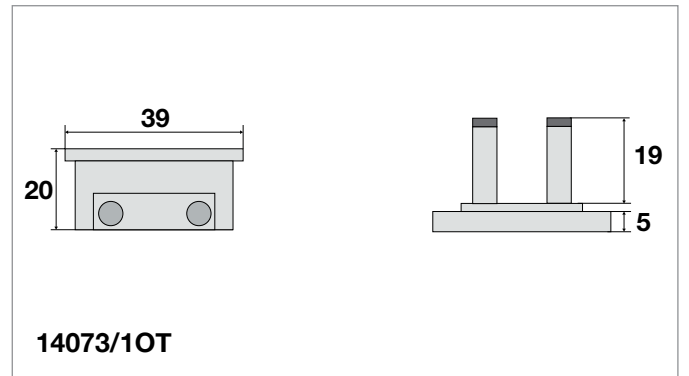
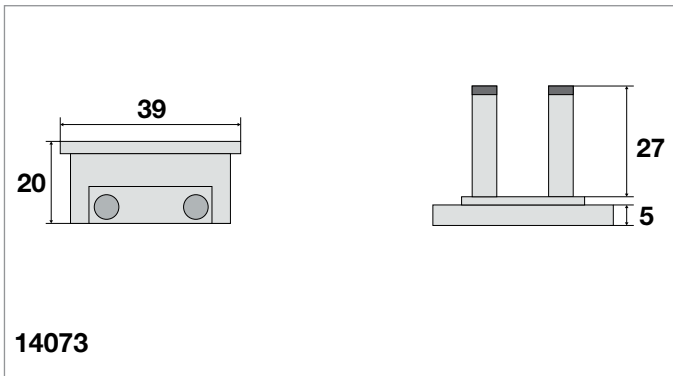
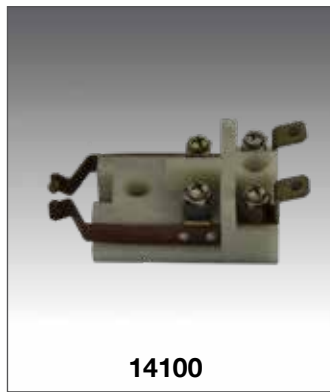

Codice / Code	Descrizione
14073	Contatto OTIS lungo
14073/10T	Contatto OTIS corto
14079	Contatto SCHLIEREN TVC
14100	Contatto serratura stagna FIAM
14544	Contatto LLW OTIS

CONTATTO CONTACT

3

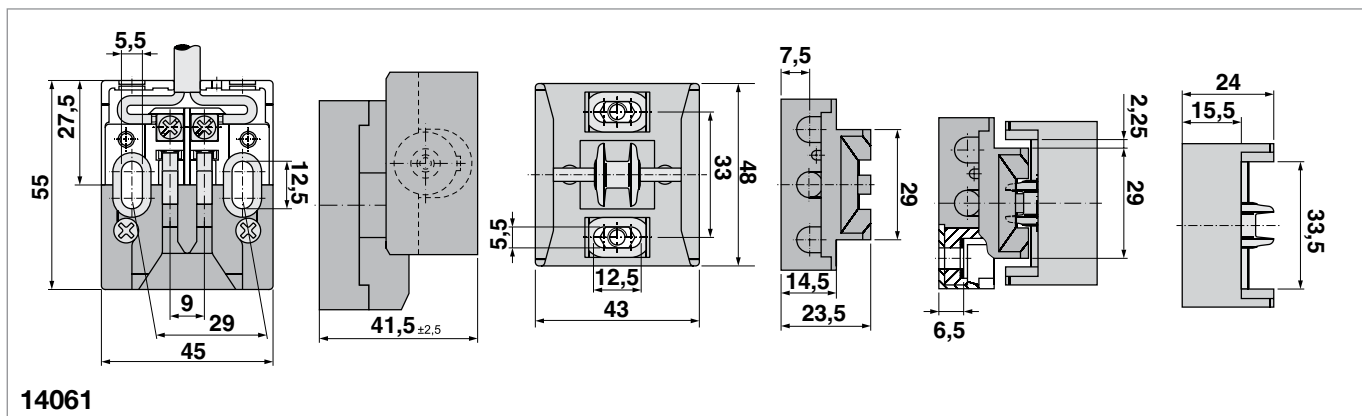
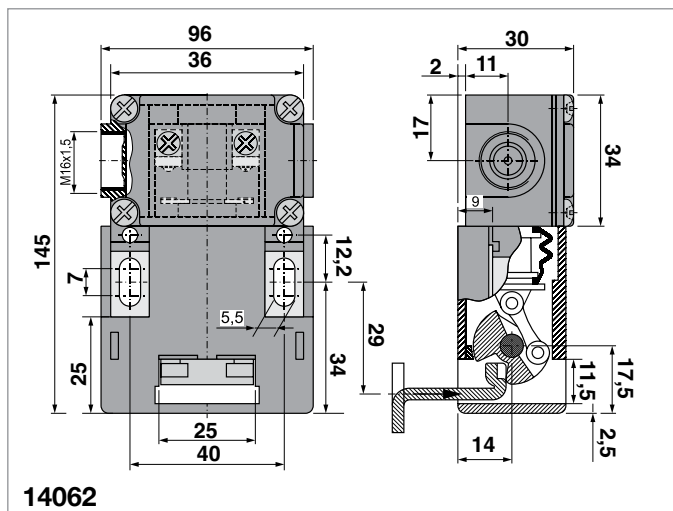
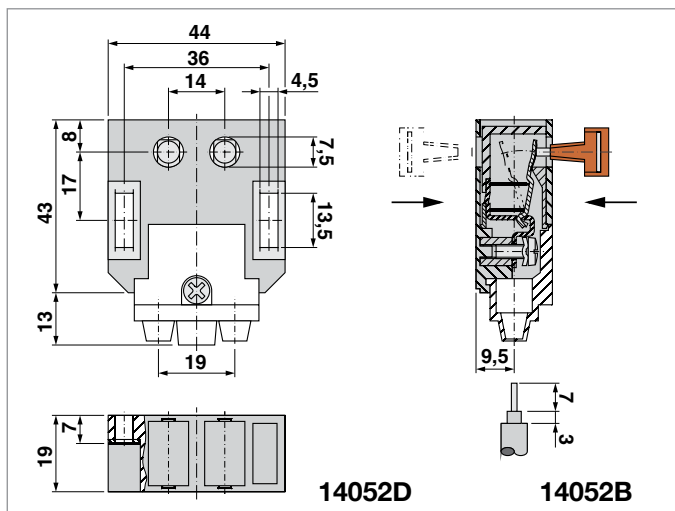
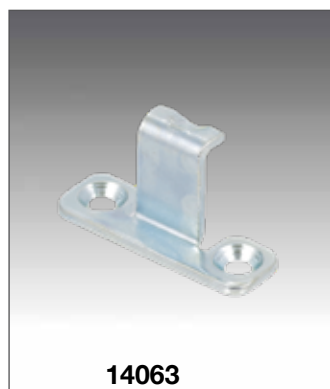

Codice / Code	Descrizione
14042	Ponte non originale h.18 interesse fori 29 mm
14042/1	Ponte h.18 (corto) (KRONENBERG PZ73) interesse fori 29 mm
14052B	Contatto KRONENBERG PZ73 entrata dal retro (KRONENBERG PZ73)
14052D	Contatto KRONENBERG PZ73 entrata dal fronte (KRONENBERG PZ73)
14055	Ponte h.21 (corto) (KRONENBERG PZ73) interesse fori 29 mm
14056	Ponte h.18 (lungo) (KRONENBERG PZ73) interesse fori 49 mm
14057	Ponte h.21 (lungo) (KRONENBERG PZ73) interesse fori 49 mm
14061	Contatto KRONENBERG RZ per porte scorrevoli
14062	Contatto stagno (ad immersione) KRONENBERG IP66/WZD
14063	Ponte BK per contatto KRONENBERG cod.14062

CONTATTO CONTACT



14059



14060



14080



14064



14065



14063/1

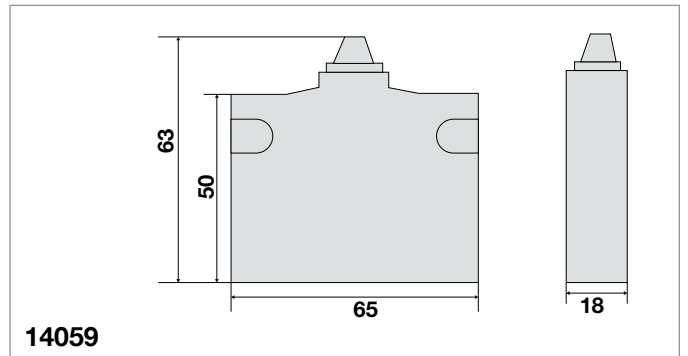

14059

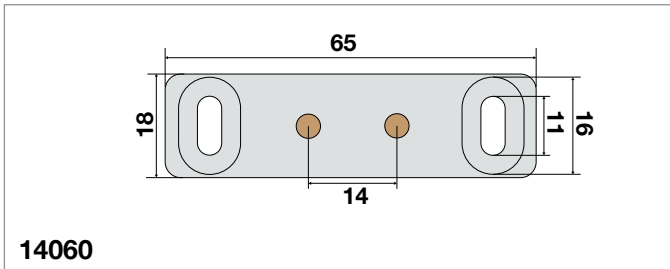

14060

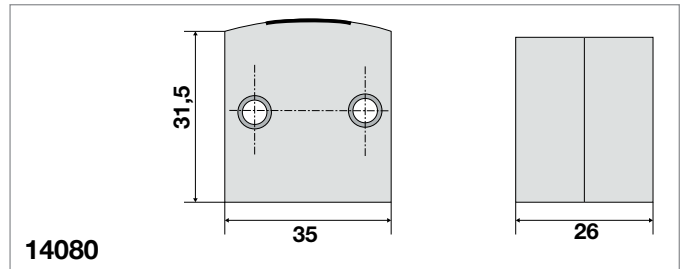

14080

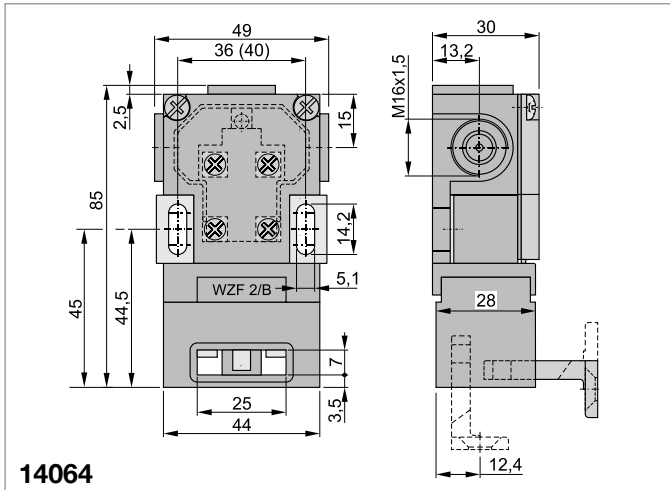

14064

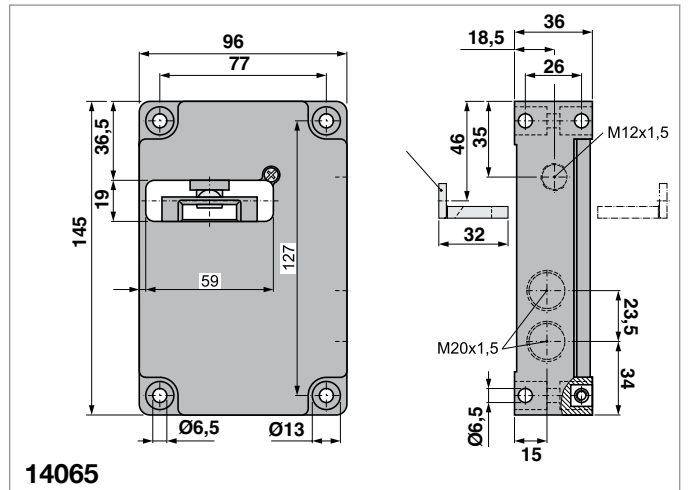

14065

Codice / Code	Descrizione
14059	Contatti KRONENBERG 1510 per porte a ghigliottina
14060	Ponti KRONENBERG 1510
14063/1	Ponte KRONENBERG
14064	Contatto KRONENBERG WZF2-S stagno IP66 per porte a ghigliottina più chiave BB-MS
14065	Contatto d'accostamento completo di ponte KRONENBERG WZV2 con circuito di sicurezza + elettrochiavistello IP54
14080	Contatto SCHLIEREN GK

CONTATTO CONTACT

3



14062/1



14078



14078/1



14545

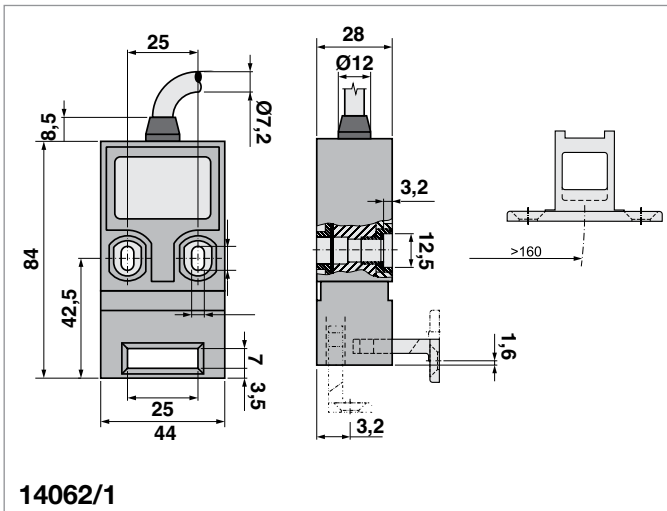

14062/1

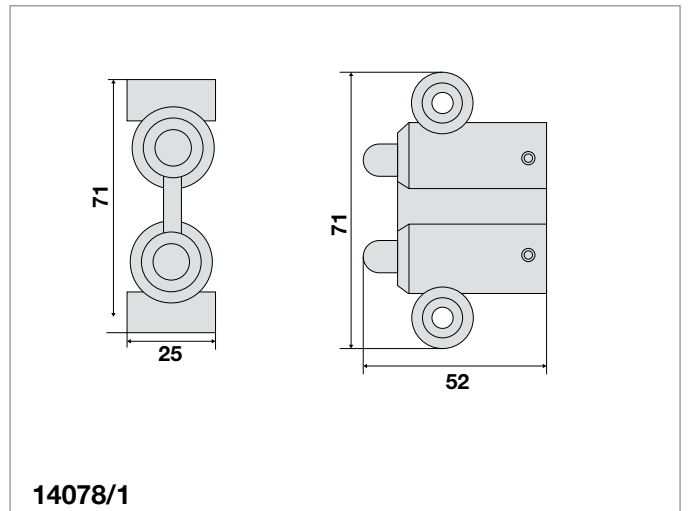

14078/1

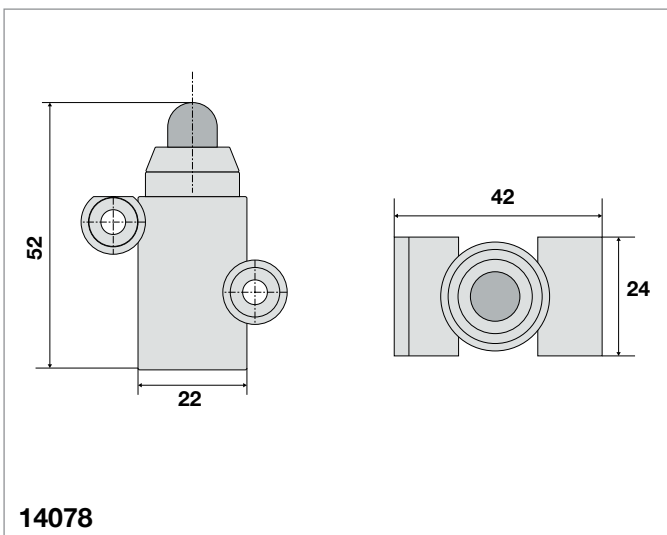

14078

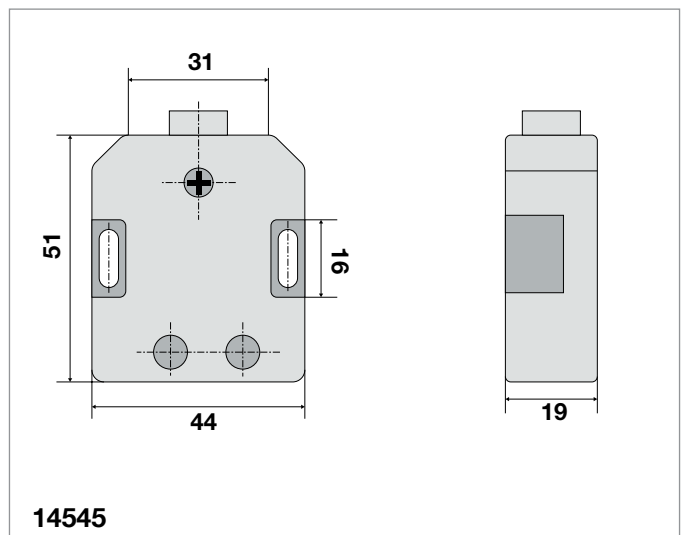

14545

Codice / Code	Descrizione
14062/1	Contatto Atex Antideflagrante KRONENBERG / WZF 2-D-Ex Entrata dal fronte WZF 2-B-Ex Entrata dal retro WZF 2-B-Ex Entrata da sotto
14063/1	Ponte attuatore
14078	Contatto SCHLIEREN TK
14078/1	Contatto doppio SCHLIEREN TK
14545	Contatto OTIS LM completo di ponte e staffe di fissaggio per nuova esecuzione

CONTATTO CONTACT

3



14021



14022



14050



14072

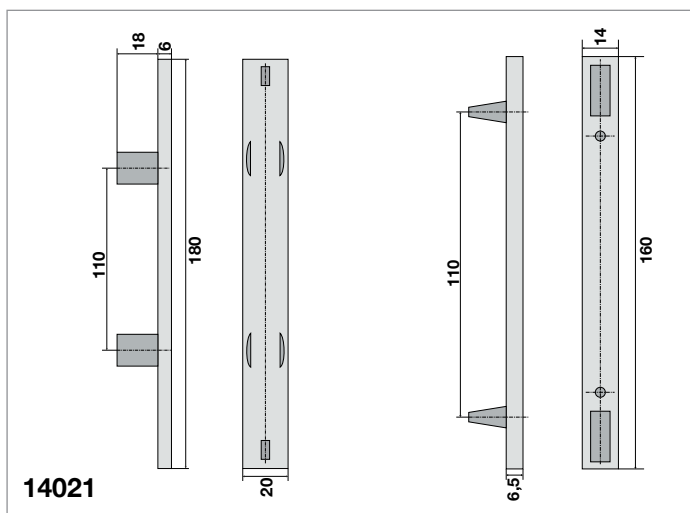

14021

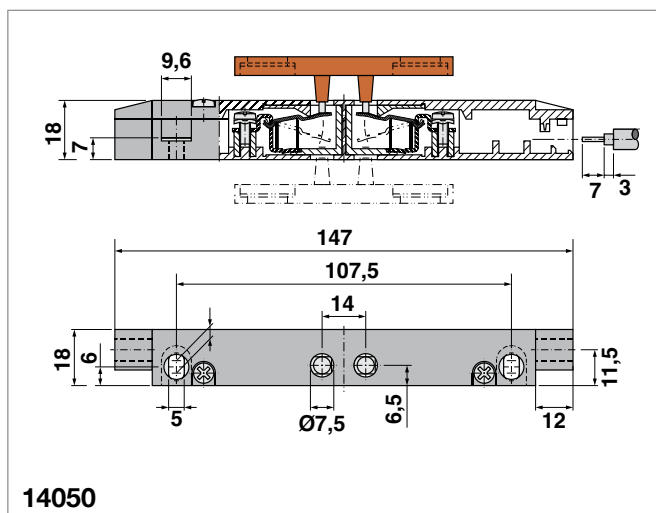

14050

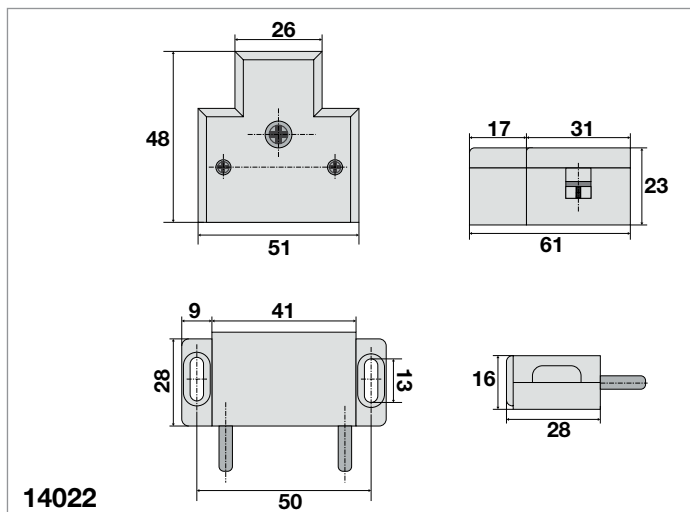

14022

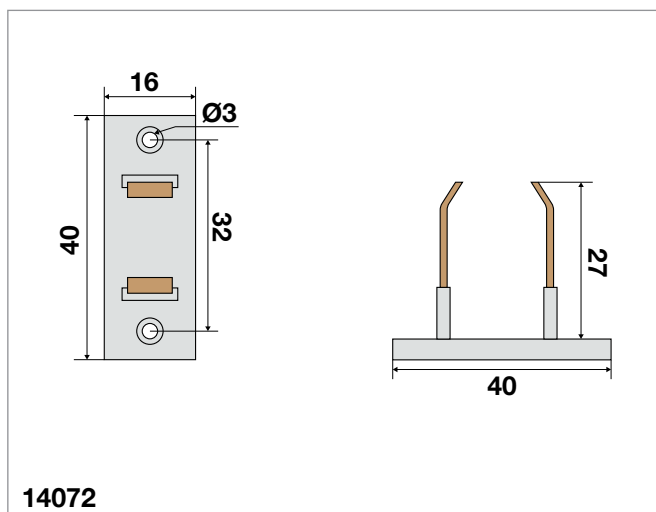

14072

Codice / Code	Descrizione
14021	Contatto portine FIAM
14022	Contatto portine SABIEM
14042/1	Ponte h.18 (corto)
14050	Contatto KRONENBERG DZ73
14055	Ponte h.21 (corto)
14056	Ponte h.18 (lungo)
14057	Ponte h.21 (lungo)
14072	Ponte OTIS LM vecchia esecuzione

CONTATTO CONTACT

3

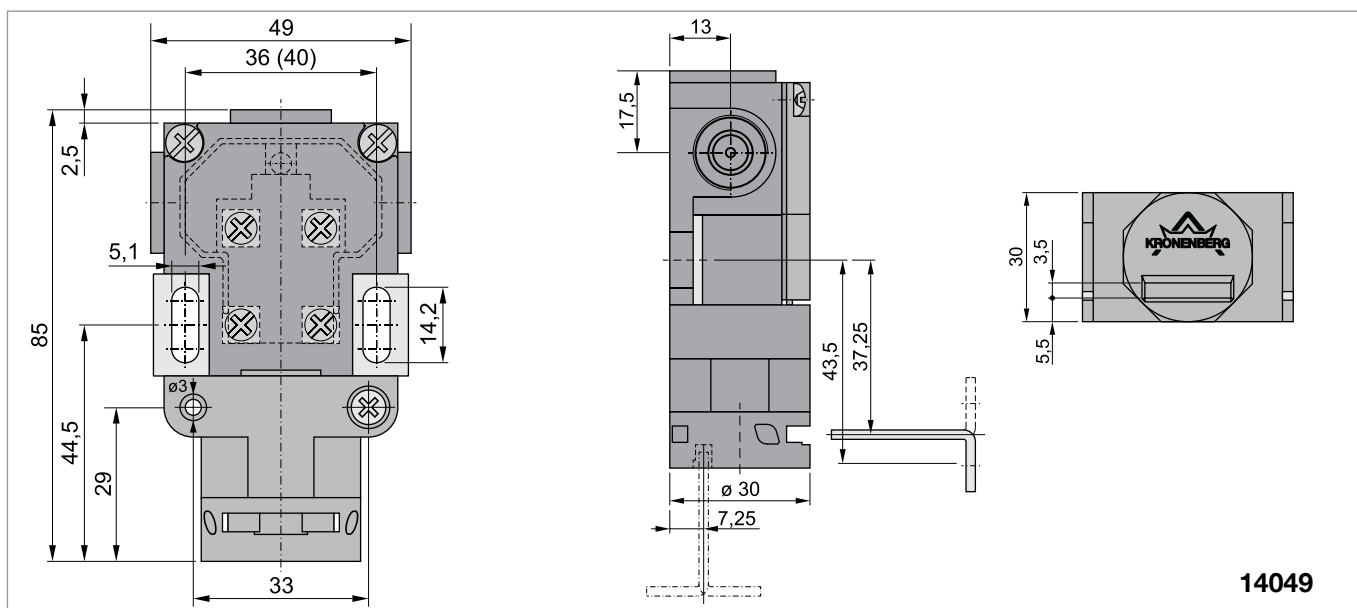
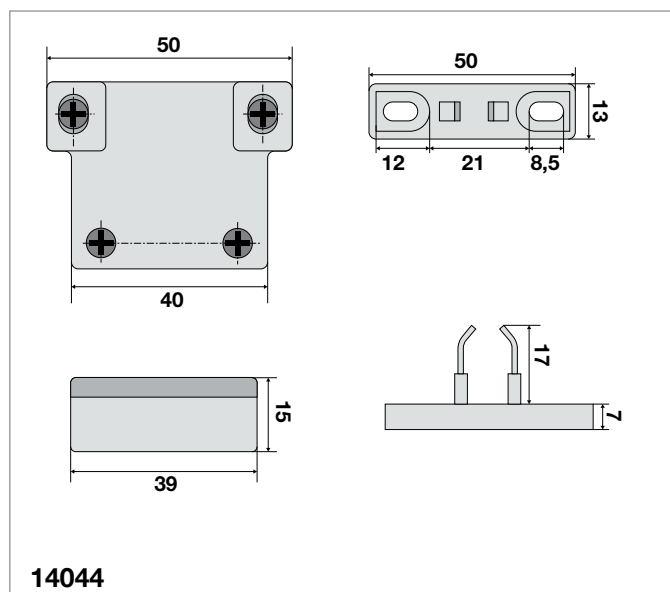
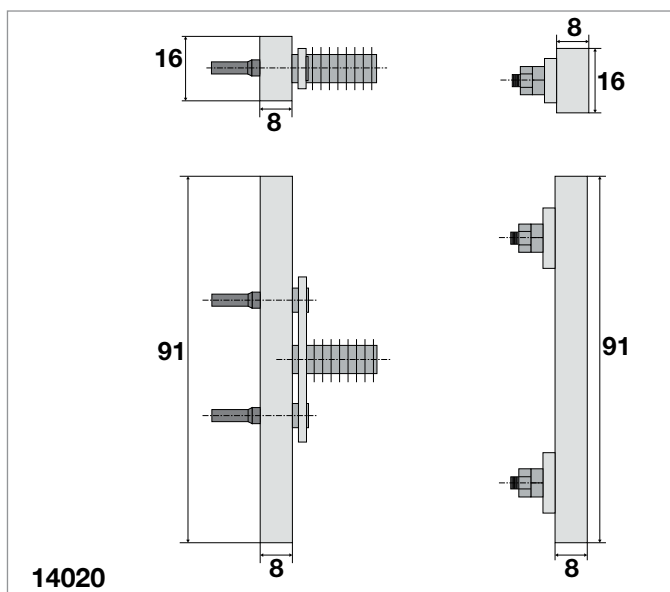

Codice / Code	Descrizione
14020	Contatto portine BASSETTI
14044	Contatto completo porte automatiche CENTODUCATI
14049	Contatto KRONENBERG WZA completo di chiave BBA

CONTATTO FINECORSA LIMIT SWITCH CONTACT



14005/1



14006/A



14009



14010

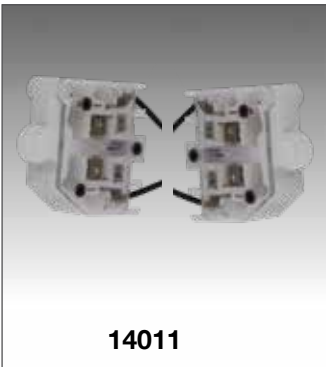

14011

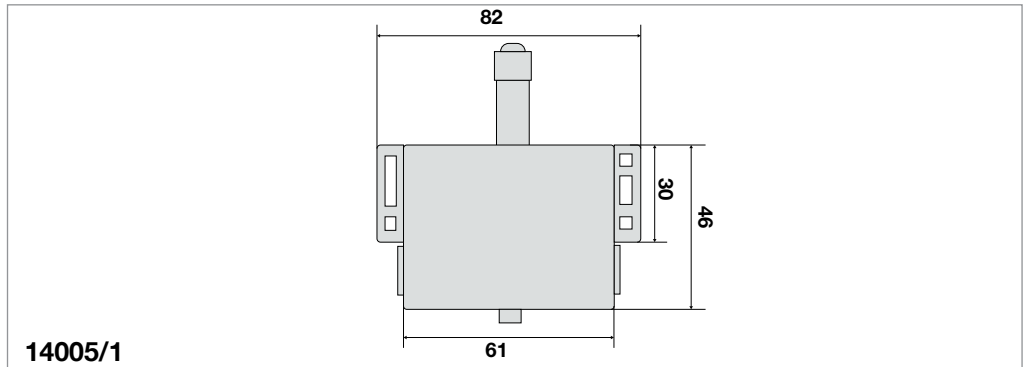

14005/1

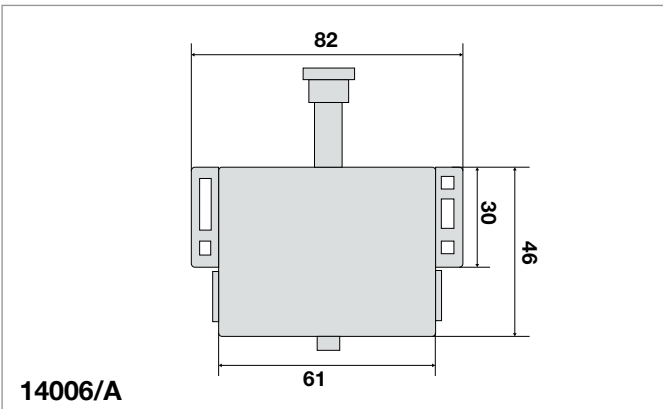

14006/A

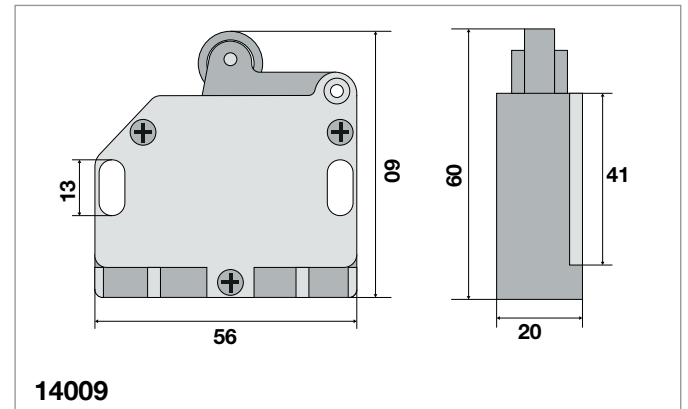

14009

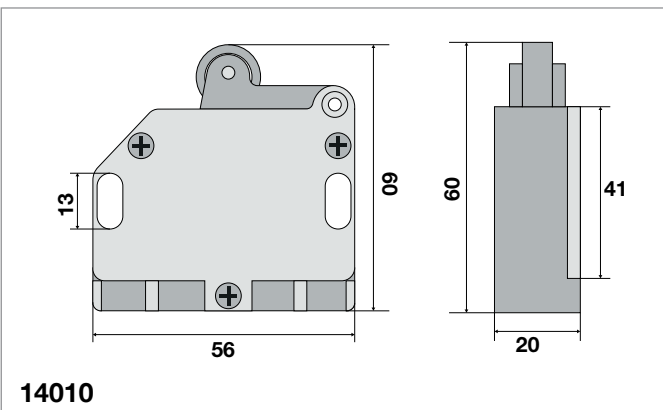

14010

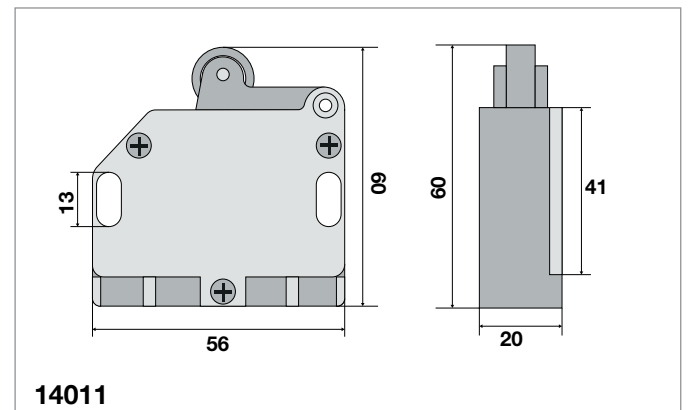

14011

Codice / Code	Descrizione
14005/1	Finecorsa a sfera
14006/A	Finecorsa a rotella
14009	Contatto finecorsa apertura FIAM
14010	Contatto finecorsa chiusura FIAM
14011	Kit Contatto finecorsa FIAM n.c - n.a

CONTATTO FINECORSA LIMIT SWITCH CONTACTS

3



14001



14002



14003



14004



14007/1

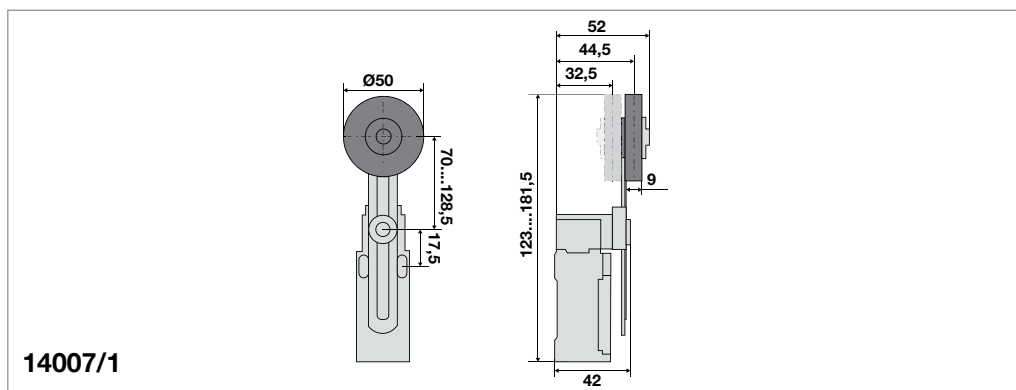

14007/1

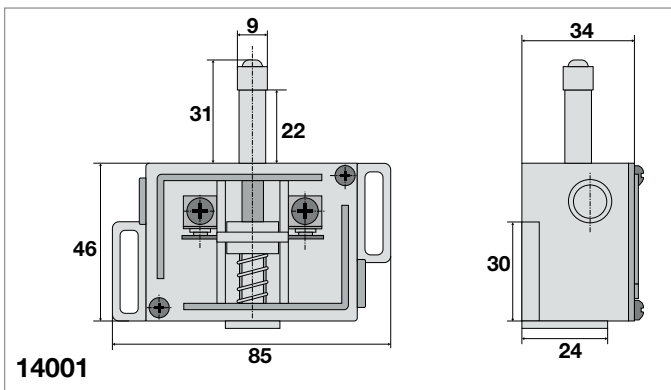

14001

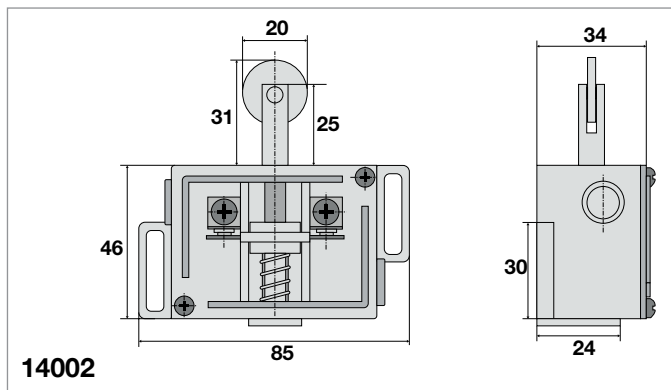

14002

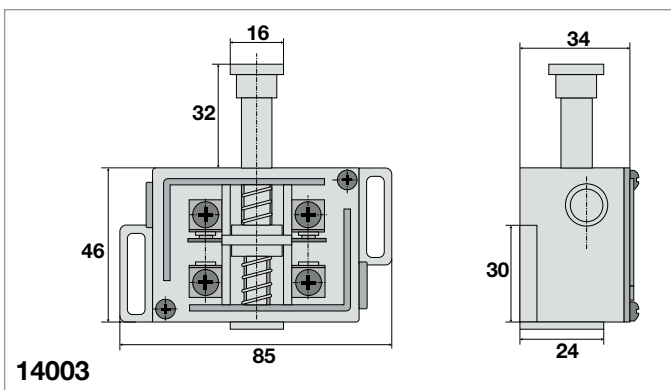

14003

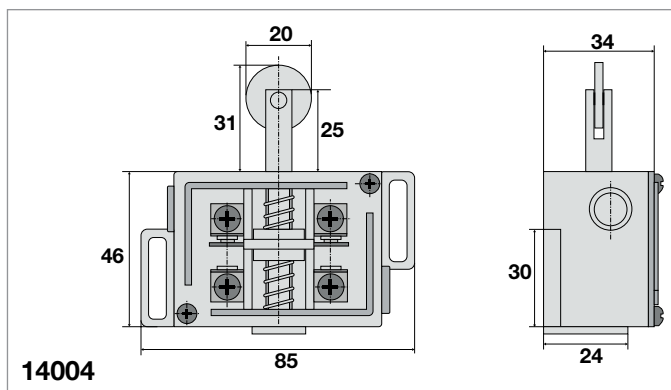

14004

Codice / Code	Descrizione
14001	Finecorsa a sfera con 1 CNC
14002	Finecorsa a rotella con 1 CNC
14003	Finecorsa a pistone con 1 CNA + CNC
14004	Finecorsa a rotella con 1 CNA + CNC
14007/1	Finecorsa a rotella con 1 CNC + CNA

CONTATTO FINECORSA LIMIT SWITCH CONTACTS

3



14005



14006/1



14006/2



14007

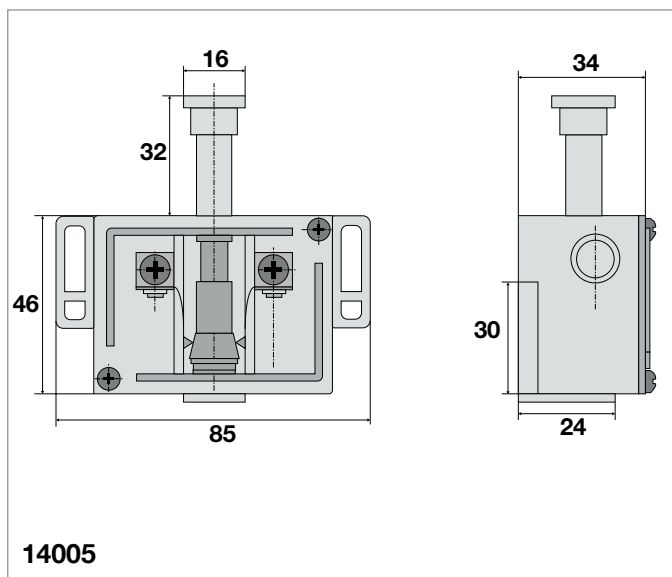

14005

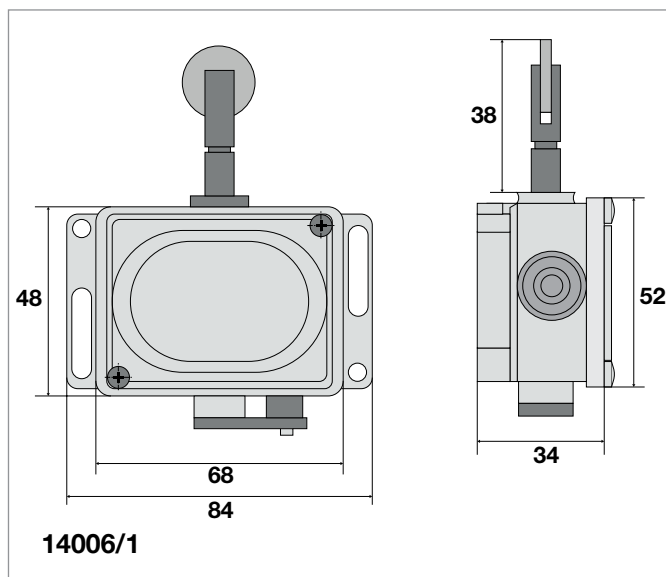

14006/1

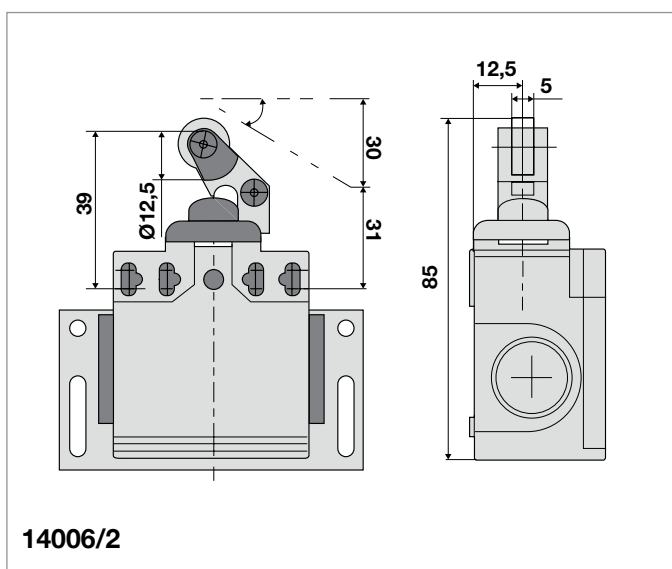

14006/2

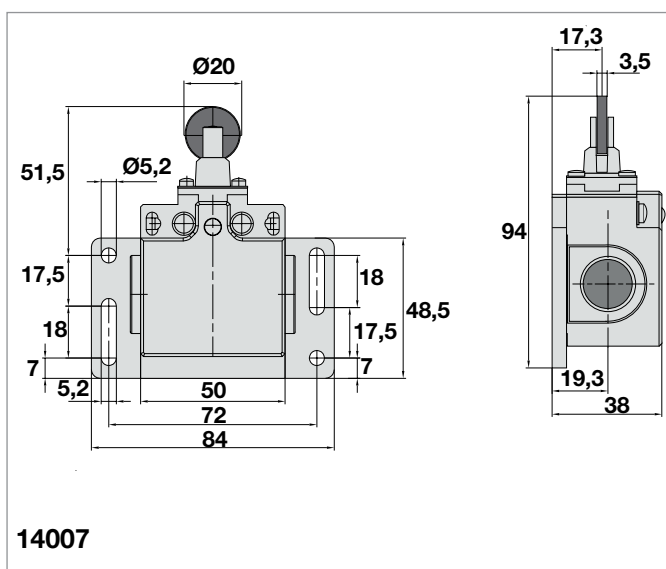

14007

Codice / Code	Descrizione
14005	Finecorsa a tampone con 1 CNC a stacco obbligato
14006/1	Finecorsa a rotella con 1 CNC a distacco obbligato
14006/2	Finecorsa a sfera con 1CNC + CNA instabile leva disassata
14007	Finecorsa a rotella a 1 CNA + CNC

MICROSWITCH MICROSWITCH

3

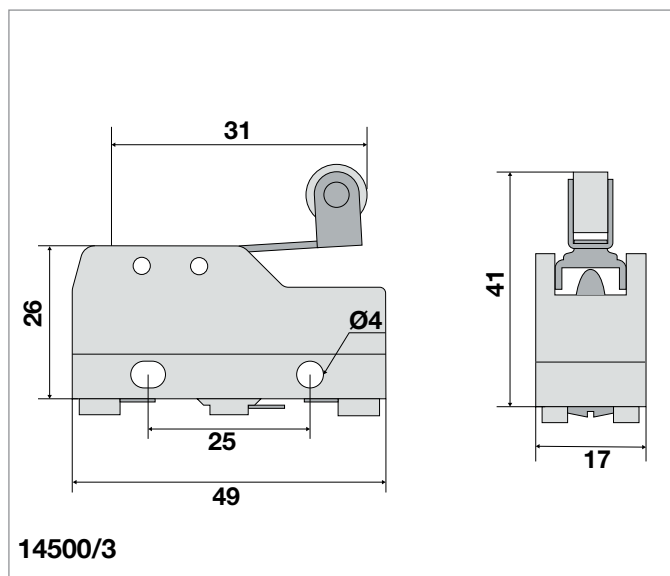
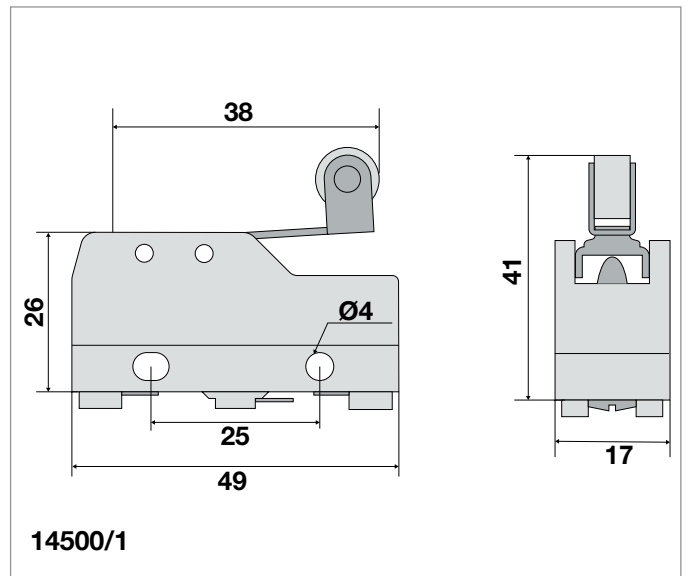
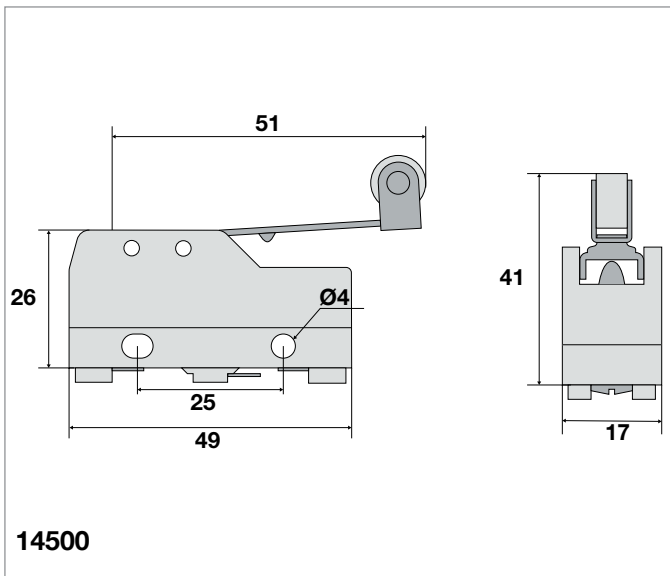

Codice / Code	Descrizione
14500	Microswitch BASSETTI STANDARD MS 55
14500/1	Microswitch leva corta MS 58
14500/3	Microswitch lava corta MS 59

MICROSWITCH MICROSWITCH

3

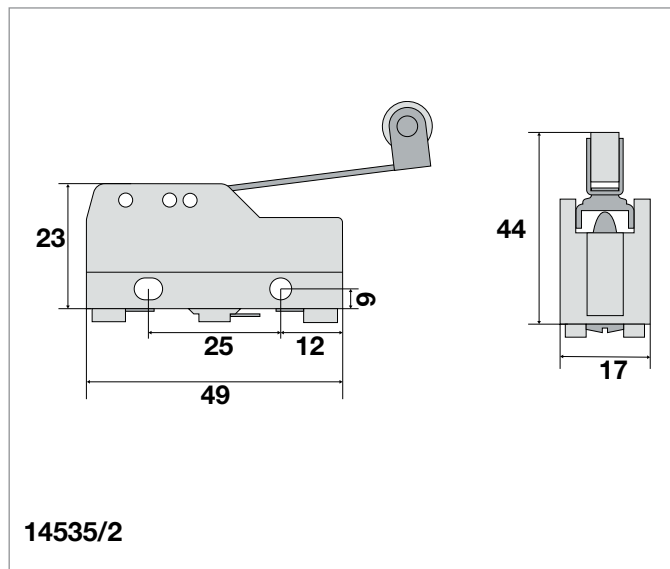
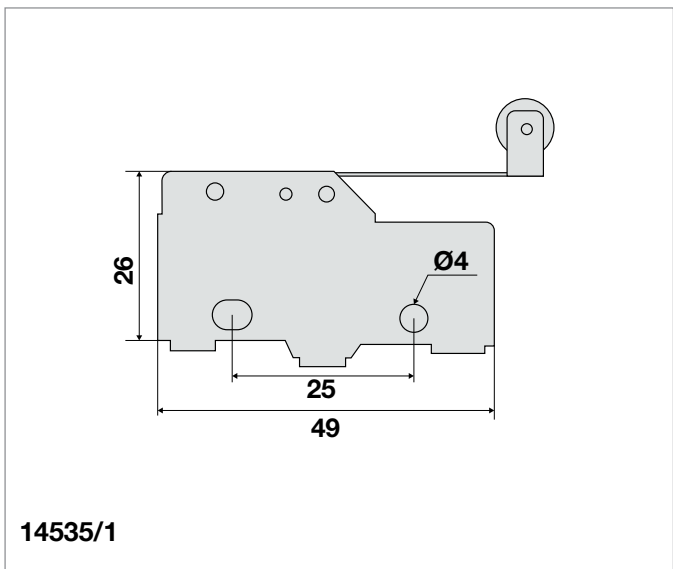
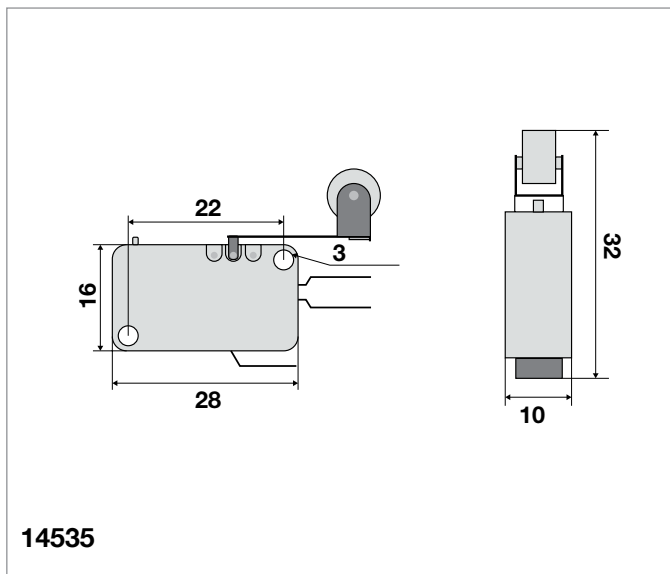
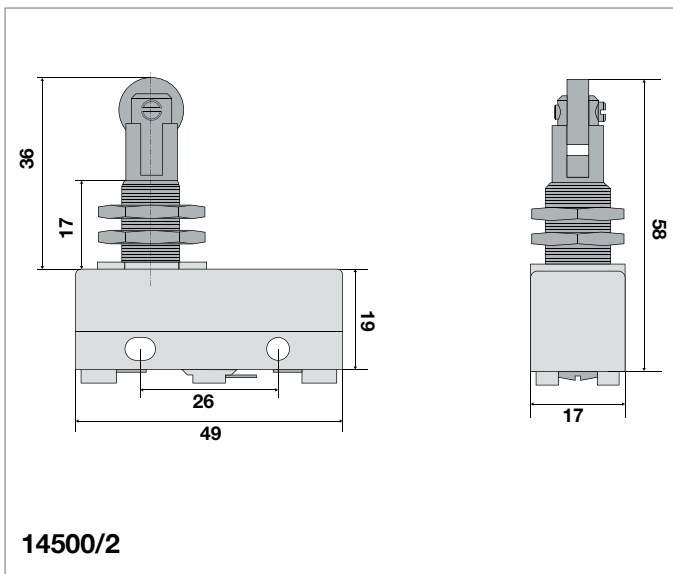

Codice / Code	Descrizione
14500/2	Microswitch MS 20
14535	Microswitch mignon FORSID
14535/1	Microinterruttore a leva corta G33
14535/2	Microinterruttore a leva lunga G33 D2 2

INTERRUTTORI A CHIAVE KEY SWITCH

3



DL070 DL071



DL072 DL076



DL077 DL080

Interruttori a chiave

Codice / Code	Descrizione
DL070	Interruttore a chiave E3350 1 estrazioni
DL071	Interruttore a chiave E3350 2 estrazioni

Interruttori a chiave

Codice / Code	Descrizione	
DL072	Interruttore a chiave 0-1 chiave estraibile in posizione 0	<p>Chiave con cifratura standard G9225. Su richiesta cifrature differenti.</p> <p>Materiale: corpo in Zama passivato rivestito in acciaio inox 18/8, supporto parti elettriche in nylon 30% vetro, giro chiave 90°</p> <p>Tensione: 250Vca - 1,5A.</p> <p>Terminali d.3mm a saldare</p> <p>Temperatura di funzionamento :0°C +85°C</p> <p>Vita operativa: 10.000 operazioni</p> <p>Dimensioni: corpo diametro 18 x 41 mm, ghiera diametro 23 mm</p>
DL073	Interruttore a chiave 0-1 chiave estraibile in posizione 0-1	
DL074	Interruttore a chiave 2NA 1-0-2 chiave estraibile in 3 posizione	
DL075	Chiave, cifratura No....	
DL076	Anello d.28 x 8,520 mm Ribasso 8 mm, alluminio	

Interruttori a chiave KA

Codice / Code	Descrizione	
DL077	Interruttore a chiave K.A con ritorno a molla	<p>Chiave con cifratura standard 505. Su richiesta cifratura differenti.</p> <p>Materiale: corpo in Zama passivato, supporto parti elettriche in nylon, giro chiave 90°.</p> <p>Tensione 250Vca - 1,5 A. Terminali d.3 mm a saldare.</p> <p>Temperatura di funzionamento: 0° +85°</p> <p>Vita operativa: 10.000 operazioni</p> <p>Dimensioni: corpo diametro 19 x 30 mm, ghiera diametro 22,4</p>
DL078	Interruttore a chiave K.A 2 posizioni - 1 estrazione	
DL079	Interruttore a chiave K.A 2 posizioni - 2 estrazione	
DL080	Chiave KY cifratura.....	

RICAMBI QUADRI ASCENSORI ELETTROMECCANICI
ELECTROMECHANICAL LIFT BOARDS SPARE PARTS

CONDENSATORI

CAPACITOR

Condensatori elettrolitici	4.18
<i>Electronic capacitor</i>	

CONTATTI

CONTACT

Connessione per contatto forza motrice teleruttore SABIEM	4.6
<i>Connection for drive force contact for SABIEM contactor</i>	

Contatto ausiliario teleruttore SAFOV a carbone	4.5
<i>Auxiliary contact for SAFOV contactor in carbon</i>	

Contatto ausiliario teleruttore N.C BASSETTI	4.5
<i>Auxiliary contact for N.C BASSETTI contactor</i>	

Contatto ausiliario teleruttore N.A BASSETTI	4.6
<i>Auxiliary contact N.A BASSETTI contactor</i>	

Contatto ausiliario teleruttore RJ22-RU22 SCHINDLER	4.7
<i>Auxiliary contact for SCHINDLER RJ22-RU22 contactor</i>	

Contatto di forza motrice teleruttore T01 FIAM	4.10
<i>Additional brushes for motor T01 FIAM contactor</i>	

Contatto di forza motrice teleruttore T05 FIAM	4.11
<i>Additional brushes for motor T05 FIAM contactor</i>	

Contatto ausiliario aggiuntivo in chiusura teleruttore T05 FIAM	4.11
<i>Additional auxiliary contact for closing T05 FIAM contractor</i>	

Contatto ausiliario aggiuntivo in apertura teleruttore T05 FIAM	4.11
<i>Additional auxiliary contact for closing T05 FIAM contractor</i>	

Contatto CGE tipo 372-373-374 per polo principale FIAM	4.9
<i>Contact CGE type 372- 373-374 for main pole FIAM</i>	

Contatto fisso relè RA SCHINDLER	4.8
<i>Fixed relay contact RA SCHINDLER</i>	
Contatto fisso tripolare UA SCHINDLER	4.8
<i>Fixed Triple-pole contact UA SCHINDLER</i>	
Contatto forza motrice teleruttore MG 5 SCHINDLER	4.8
<i>Drive force contact for MG 5 SCHINDLER contactor</i>	
Contatto forza motrice teleruttore SAFOV a carbone	4.5
<i>Driving force contact for SAFOV contactor in carbon</i>	
Contatto forza motrice teleruttore SABIEM a carbone	4.5
<i>Driving force contact for SABIEM contactor in carbon</i>	
Contatto forza motrice 40 A teleruttore BASSETTI	4.6
<i>Drive force contact for BASSETTI 40° contactor</i>	
Contatto forza motrice AGF 80 FIAM	4.6
<i>Drive force contact for AGF 80 FIAM</i>	
Contatto forza motrice teleruttore RJ22-RU22 SCHINDLER	4.7
<i>Drive force contacts for SCHINDLER RJ22-RU22 contactor</i>	
Contatto mobile tripolare SCHINDLER UA	4.7
<i>Moveable Triple-pole contact SCHINDLER UA</i>	
Contatto relè apertura/chiusura FIAM.....	4.10
<i>Opening/closing relay contact FIAM</i>	

LAMELLA

MOVABLE BLADE

Lamella contatto relè RJ12 SCHINDLER	4.7
<i>Blade relay contact RJ12 SCHINDLER</i>	
Lamella mobile relè RA SCHINDLER	4.8
<i>Movable blade relay RA SCHINDLER</i>	

PONTE

BRIDGE

Ponte di contatto teleruttore RU22 SCHINDLER	4.8
<i>Bridge of contact for RU22 SCHINDLER contactor</i>	

RELÈ

RELAY

Relè d'apertura porte MRG SCHINDLER	4.14
<i>Opening door relay MRG SCHINDLER</i>	
Relè di piano SCHINDLER	4.14
<i>Floor relay SCHINDLER</i>	
Relè OCTAL RCP 8 FIAM - relè Octal 220V - 24V - 12V	4.13
<i>OCTAL relay RCP 8 FIAM - Octal relay 220V - 24V - 12 V</i>	
Relè ritardatore SCHINDLER	4.14
<i>Delaying relay SCHINDLER</i>	
Relè temporizzatore 60V. AC. CC. 5A 250V. AC FIAM	4.13
<i>Relay timer 60V. AC. CC. 5A 250V. AC FIAM</i>	
Relè UNDECAL RCP 8 FIAM - relè Undical 220V - 24V - 12V	4.13
<i>UNDECAL relay RCP 8 FIAM - Undical relay 220V - 24V - 12V</i>	
Zoccolo per relè OCTAL - UNDECAL	4.13
<i>Socket for relay OCTAL - UNDECAL</i>	

RESISTENZE

RESISTORS

Resistenze regolabili e non regolabili	4.15-4.16
<i>Adjustable and not adjustable resistors</i>	
Resistenza scaldolio per serbatoio	4.16
<i>Resistors for oil heater for tank</i>	

TELERUTTORI

CONTACTORS

Teleruttore AGF 80-AGF 200 con contatto ausiliario in apertura e chiusura FIAM	4.12
<i>Contactors AGF 80-AGF 200 with auxiliary contact for opening and closing FIAM</i>	
Teleruttore NF41 con contatto ausiliario in apertura FIAM	4.12
<i>Contactors NF 41 with auxiliary contact for opening FIAM</i>	

TELERUTTORI
CONTACTORS

Teleruttore NF 41 con contatto ausiliario in chiusura FIAM 4.12
Contactors NF 41 with auxiliary contact for closing FIAM

Teleruttore NF 41 polo di forza motrice FIAM 4.12
Contactors NF 41 pole for driving force FIAM

4

ZENEMATIC

Schema per la sostituzione dei raddrizzatori al silicio da 0,6A_1,5_5A_10A 4.17
Diagram for substitution rectifies of silicon from 0,6A_1,5A_5A_10A

Note: I componenti sul catalogo con riportata una specifica marca di ascensore sono utilizzati abitualmente solo da questa marca. I particolari senza marca sono utilizzati da più marche di ascensori.

Note: *The components in the catalogue with a specific lift brand are usually used only by the brand. Unbranded parts are used by multiple lift brands.*

**CONTATTO PER QUADRI MANOVRA ELETTROMECCANICI-TELERUTTORE
 POLO FORZA MOTRICE - AUSILIARI - CONTATTI RELAIS PER QUADRI
 ELETTROMECCANICI - CONTATTI CARBONE
 CONTACTS FOR BOARDS OF ELECTROMECHANICAL CONTRACTOR
 CONNECTIONS ENGINE FORCE POLE - AUXILIARIES - RELAYS CONTACTS
 FOR ELECTROMECHANICAL BOARDS COAL CONTACTS**

4

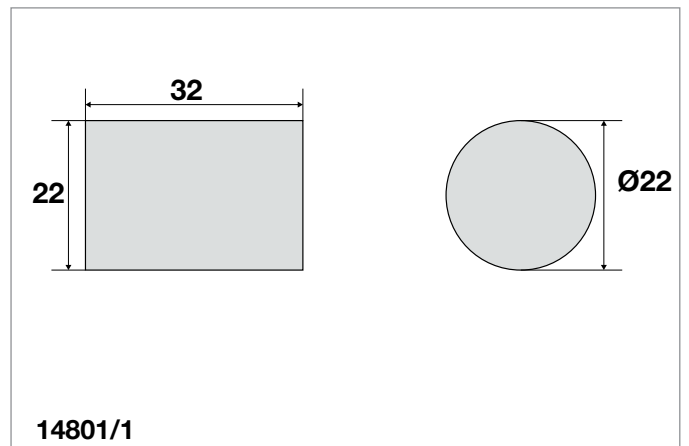
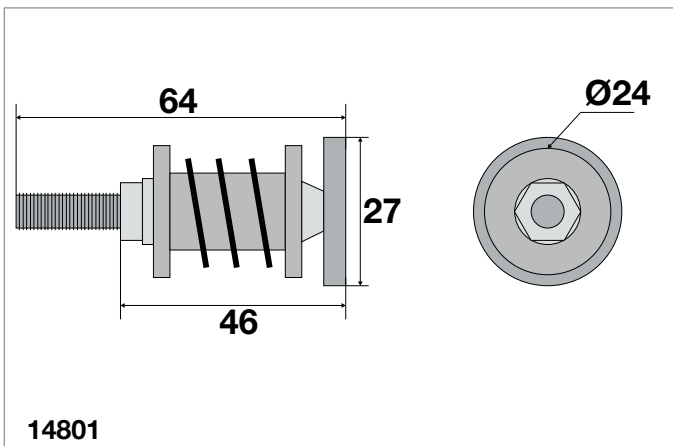
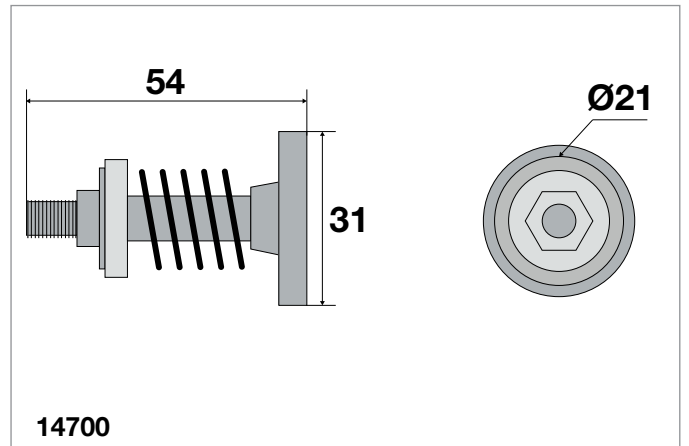
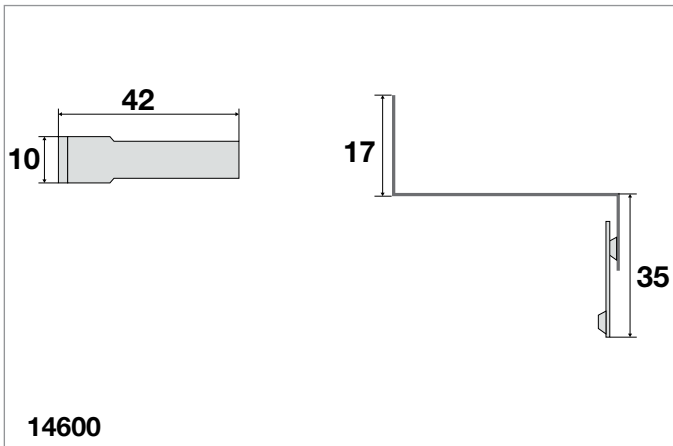
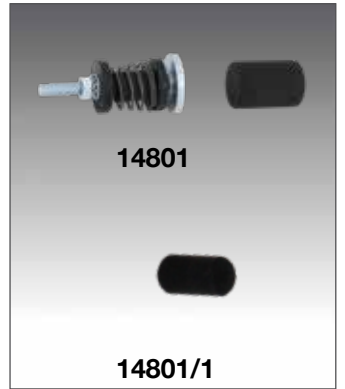
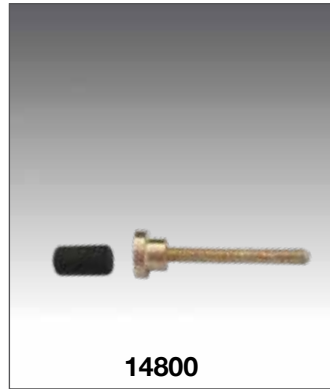
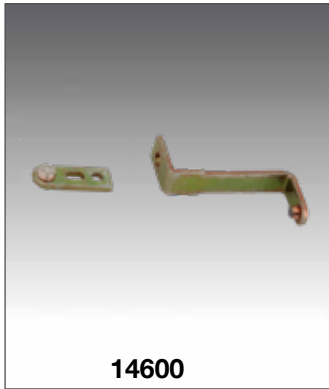

Codice / Code	Descrizione
14600	Contatto ausiliario teleruttore N.C BASSETTI
14700	Contatto forza motrice teleruttore SABIEM
14800	Contatto ausiliario completo teleruttore SAFOV
14801	Contatto forza motrice teleruttore SAFOV
14801/1	Solo carbone del cod.14801

**CONTATTO PER QUADRI MANOVRA ELETTROMECCANICI-TELERUTTORE
 POLO FORZA MOTRICE - AUSILIARI - CONTATTI RELAIS PER QUADRI
 ELETTROMECCANICI - CONTATTI CARBONE
 CONTACTS FOR BOARDS OF ELECTROMECHANICAL CONTRACTOR
 CONNECTIONS ENGINE FORCE POLE - AUXILIARIES - RELAYS CONTACTS
 FOR ELECTROMECHANICAL BOARDS COAL CONTACTS**

4

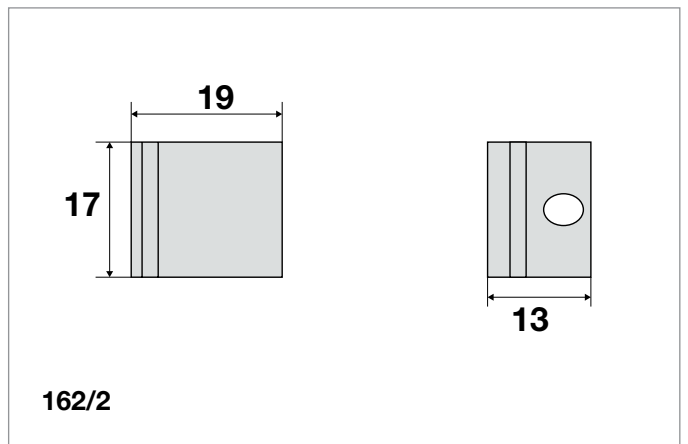
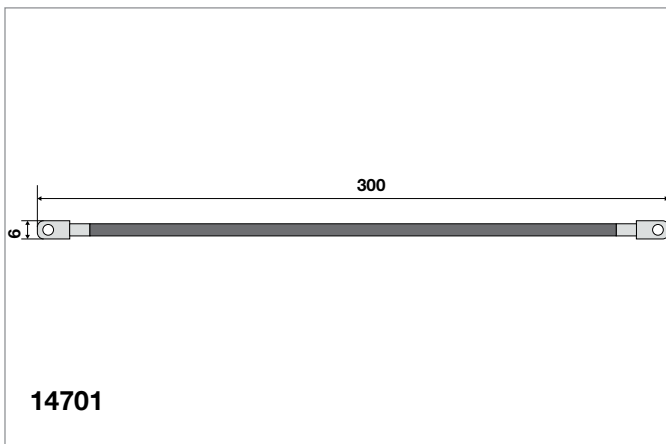
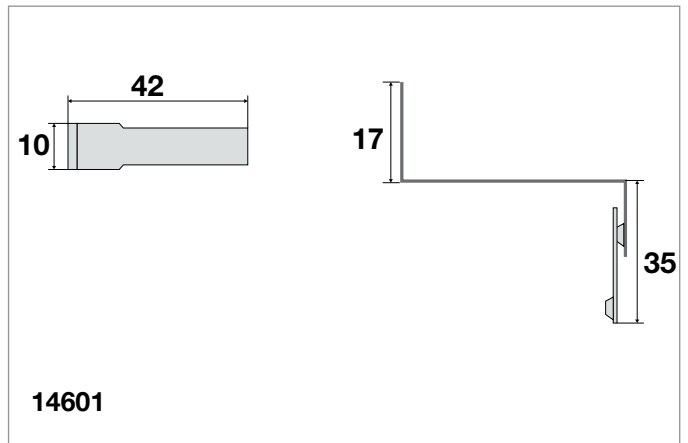
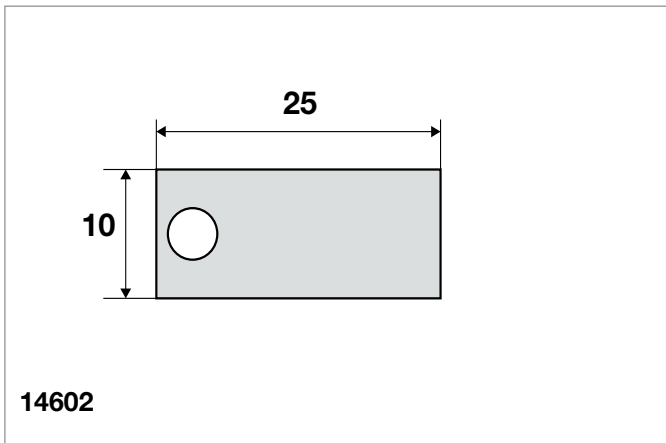

Codice / Code	Descrizione
14601	Contatto ausiliario teleruttore N.A BASSETTI
14602	Contatto forza motrice 40A teleruttore BASSETTI (coppia)
14701	Connessione per contatto forza motrice teleruttore SABIEM
162/2FI	Contatti di forza motrice teleruttore "AGF80" FIAM (coppia)

**CONTATTO PER QUADRI MANOVRA ELETTROMECCANICI-TELERUTTORE
 POLO FORZA MOTRICE - AUSILIARI - CONTATTI RELAIS PER QUADRI
 ELETTROMECCANICI - CONTATTI CARBONE
 CONTACTS FOR BOARDS OF ELECTROMECHANICAL CONTRACTOR
 CONNECTIONS ENGINE FORCE POLE - AUXILIARIES - RELAYS CONTACTS
 FOR ELECTROMECHANICAL BOARDS COAL CONTACTS**

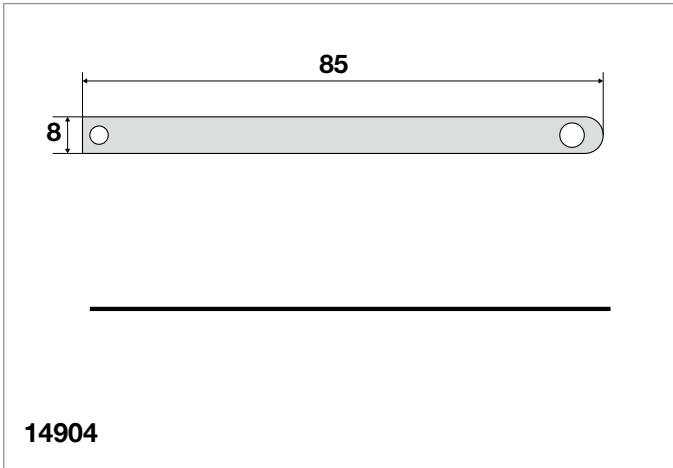
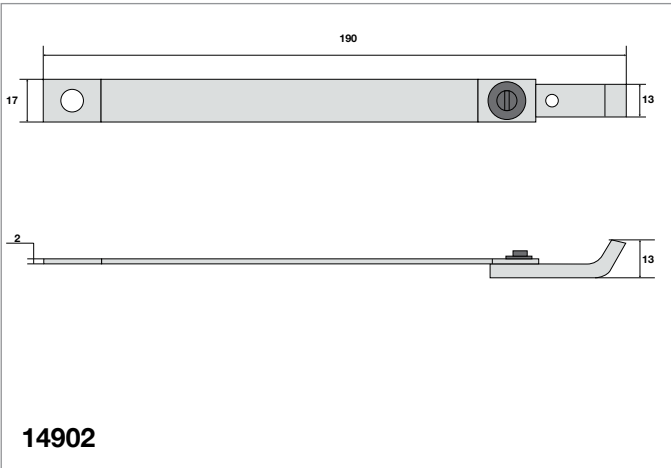
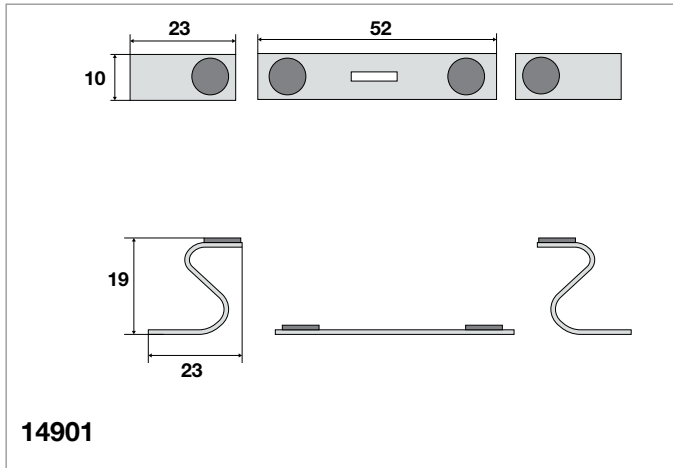
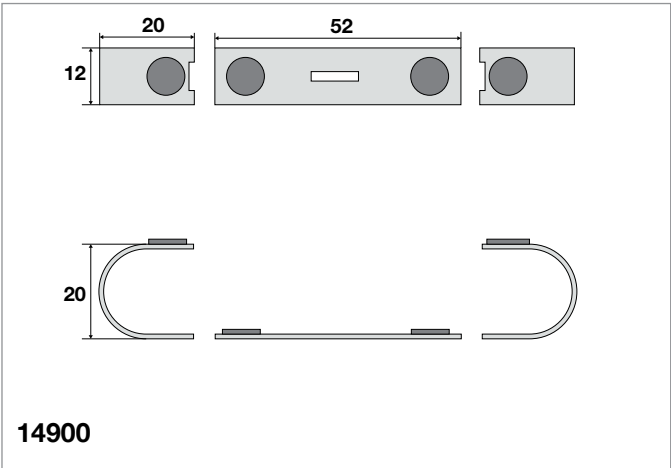
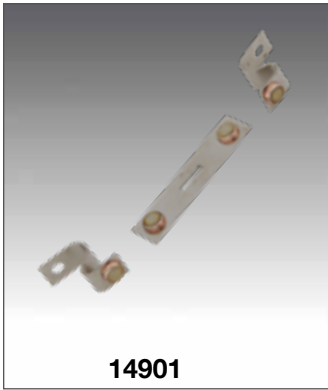
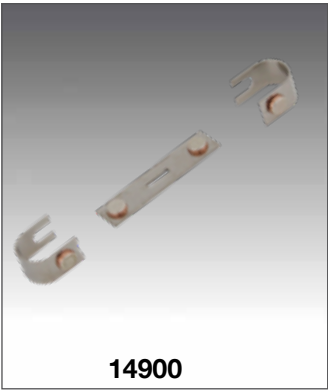

Codice / Code	Descrizione
14900	Contatto forza motrice teleruttore RJ22 SCHINDLER
14901	Contatto ausiliario teleruttore SCHINDLER RJ22-RU22
14902	Contatto mobile tripolare SCHINDLER UA
14904	Lamella contatto relè RJ12 SCHINDLER

**CONTATTO PER QUADRI MANOVRA ELETTROMECCANICI-TELERUTTORE
 POLO FORZA MOTRICE - AUSILIARI - CONTATTI RELAIS PER QUADRI
 ELETTROMECCANICI - CONTATTI CARBONE
 CONTACTS FOR BOARDS OF ELECTROMECHANICAL CONTRACTOR
 CONNECTIONS ENGINE FORCE POLE - AUXILIARIES - RELAYS CONTACTS
 FOR ELECTROMECHANICAL BOARDS COAL CONTACTS**

4

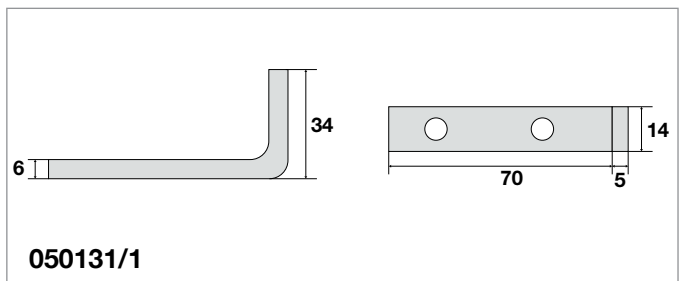
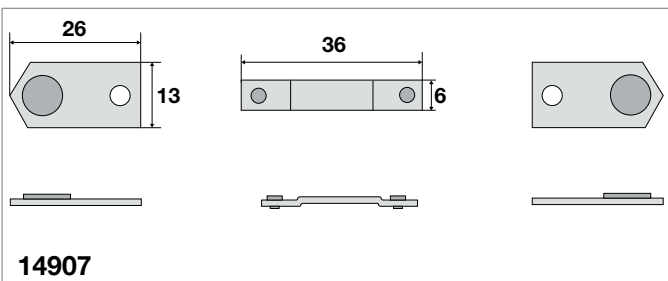
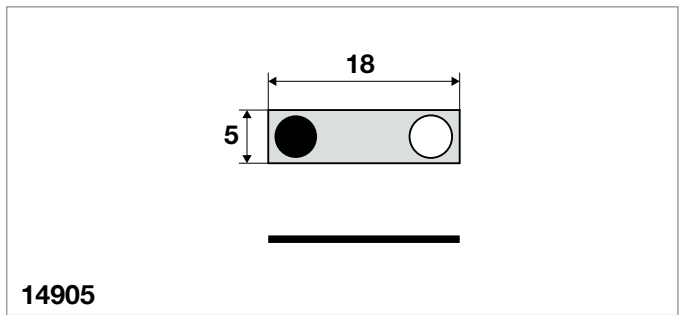
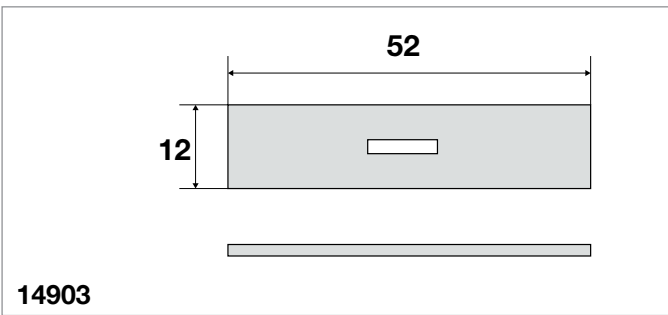
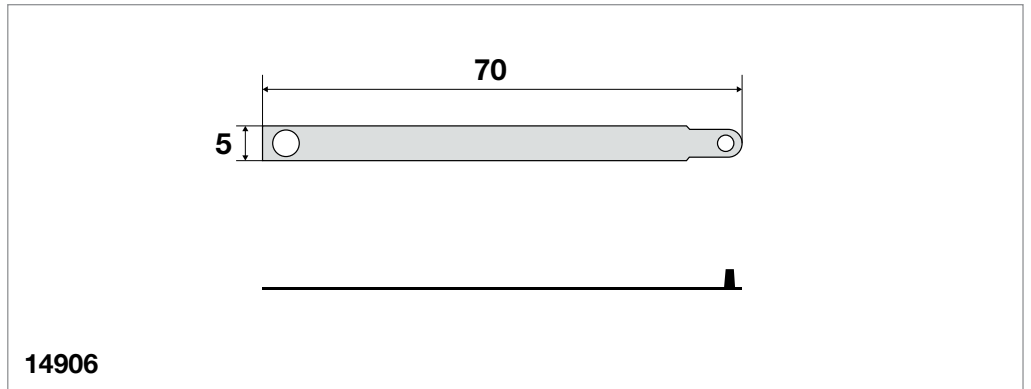

Codice / Code	Descrizione
14903	Ponte di contatto teleruttore RU22 SCHINDLER
14905	Contatto fisso relè RA SCHINDLER
14906	Lamella mobile relè RA SCHINDLER
14907	Contatto forza motrice teleruttore MG 5 SCHINDLER
050131/1	Contatto fisso tripolare UA SCHINDLER

**CONTATTO PER QUADRI MANOVRA ELETTROMECCANICI-TELERUTTORE
 POLO FORZA MOTRICE - AUSILIARI - CONTATTI RELAIS PER QUADRI
 ELETTROMECCANICI - CONTATTI CARBONE
 CONTACTS FOR BOARDS OF ELECTROMECHANICAL CONTRACTOR
 CONNECTIONS ENGINE FORCE POLE - AUXILIARIES - RELAYS CONTACTS
 FOR ELECTROMECHANICAL BOARDS COAL CONTACTS**

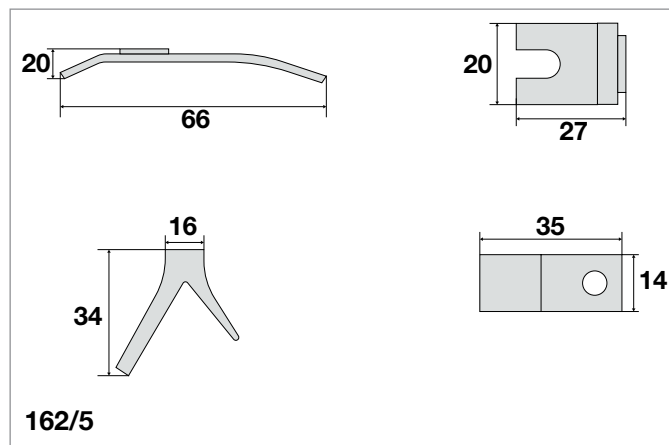
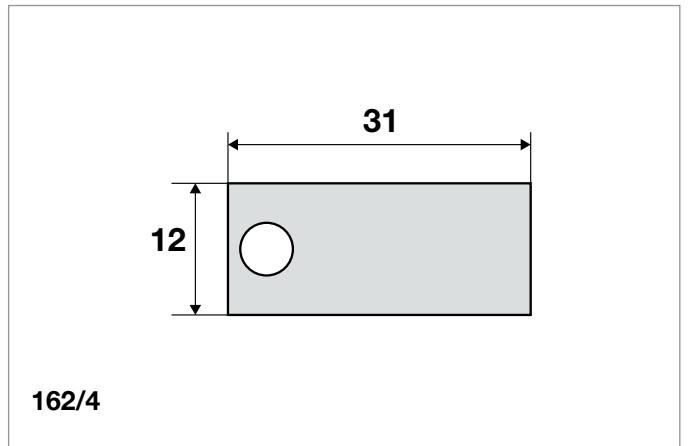
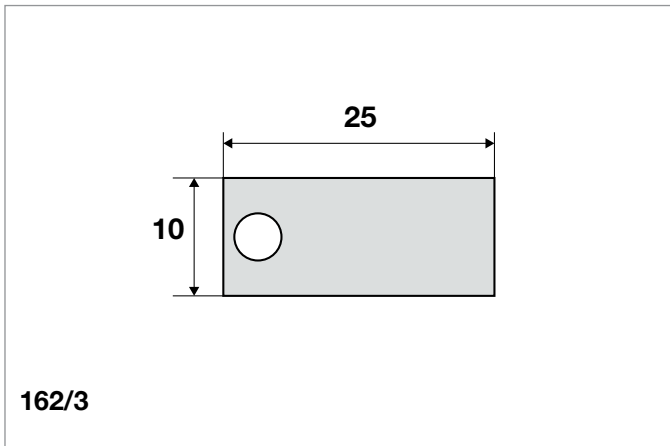

Codice / Code	Descrizione
162/3	Contatti di forza motrice CGE tipo 372 FIAM (coppia)
162/4	Contatti di forza motrice CGE tipo 373 FIAM (coppia)
162/5	Contatti di forza motrice CGE tipo 374 FIAM (coppia)

**CONTATTO PER QUADRI MANOVRA ELETTROMECCANICI-TELERUTTORE
 POLO FORZA MOTRICE - AUSILIARI - CONTATTI RELAIS PER QUADRI
 ELETTROMECCANICI - CONTATTI CARBONE
 CONTACTS FOR BOARDS OF ELECTROMECHANICAL CONTRACTOR
 CONNECTIONS ENGINE FORCE POLE - AUXILIARIES - RELAYS CONTACTS
 FOR ELECTROMECHANICAL BOARDS COAL CONTACTS**

4

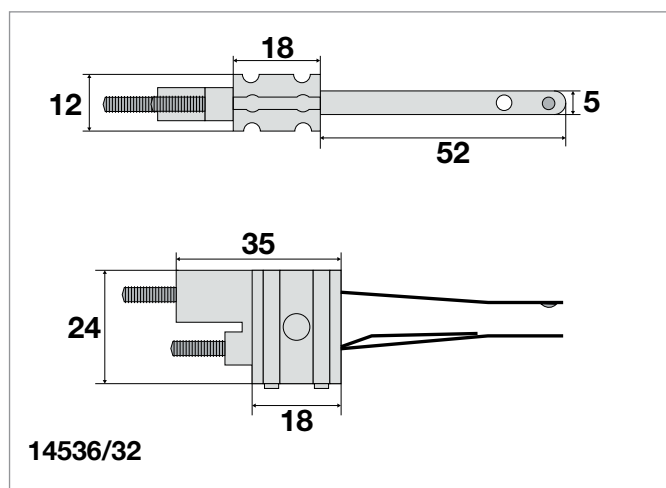
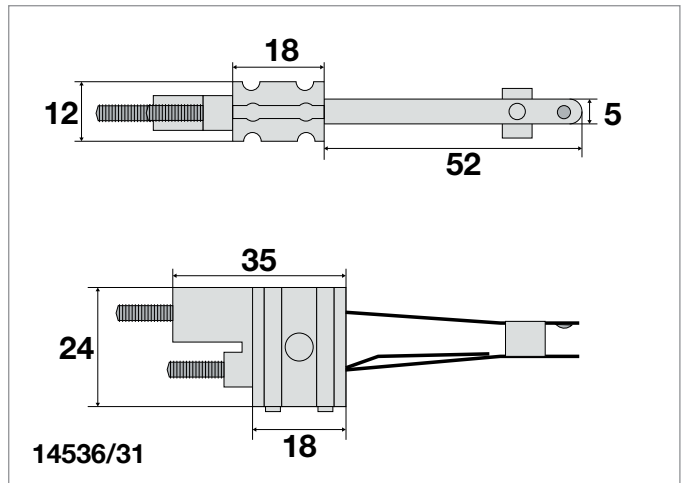
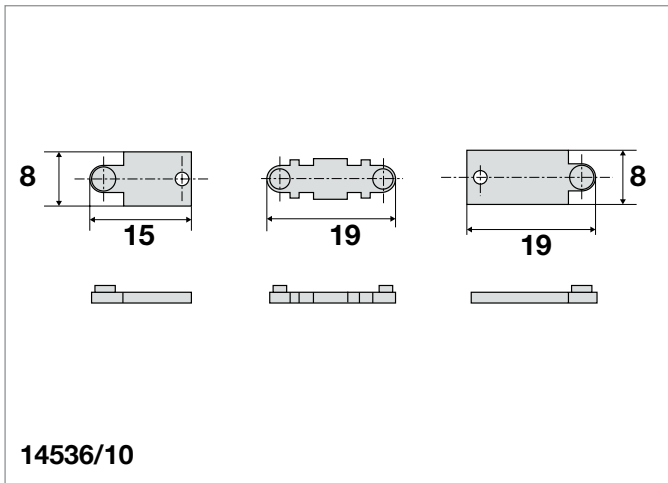

Codice / Code	Descrizione
14536/10	Contatto di forza motrice teleruttore "T01" FIAM
14536/31	Contatto relè d'apertura FIAM
14536/32	Contatto relè di chiusura FIAM

**CONTATTO PER QUADRI MANOVRA ELETTROMECCANICI-TELERUTTORE
 POLO FORZA MOTRICE - AUSILIARI-CONTATTI RELAIS PER QUADRI
 ELETTROMECCANICI - CONTATTI CARBONE
 CONTACTS FOR BOARDS OF ELECTROMECHANICAL CONTRACTOR
 CONNECTIONS ENGINE FORCE POLE - AUXILIARIES - RELAYS CONTACTS
 FOR ELECTROMECHANICAL BOARDS COAL CONTACTS**

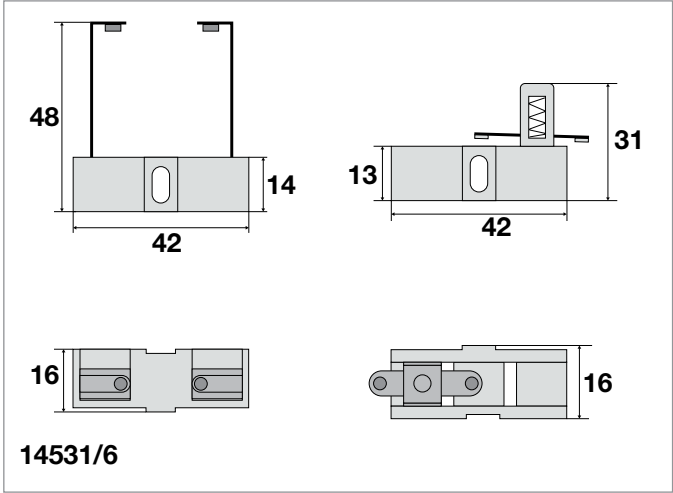
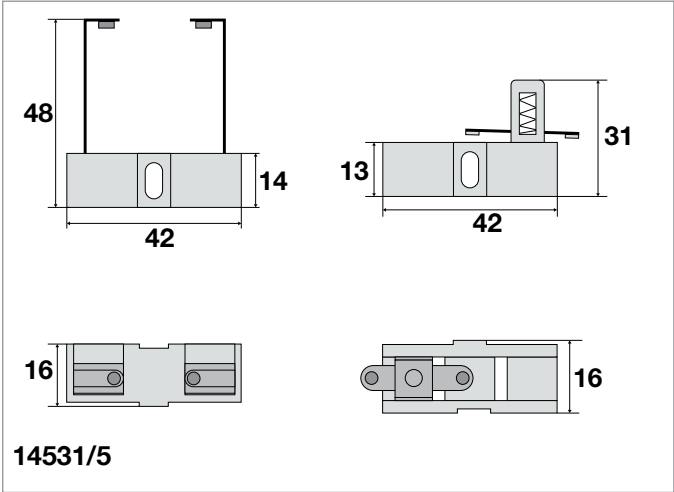
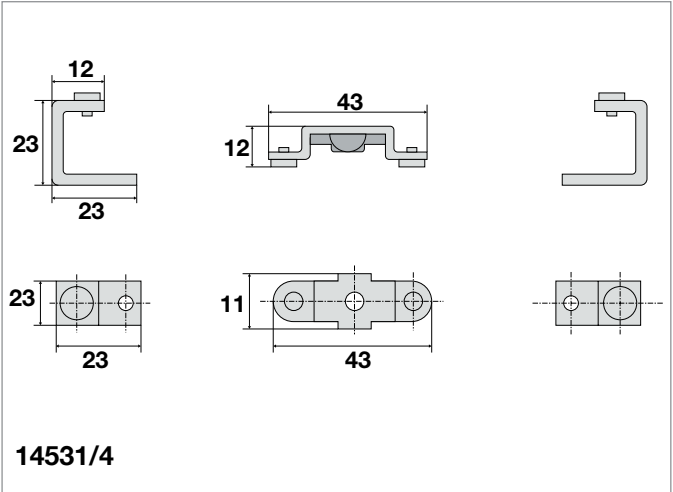
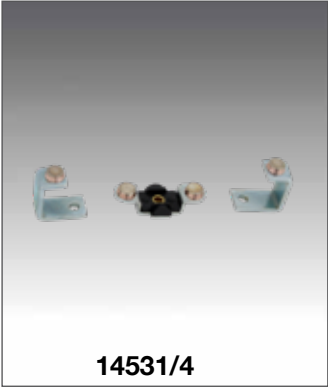

Codice / Code	Descrizione
14531/4	Contatti di forza motrice teleruttore "T05" FIAM
14531/5	Contatto ausiliario aggiuntivo in chiusura "teleruttore T05" FIAM
14531/6	Contatto ausiliario aggiuntivo in apertura "teleruttore T05" FIAM

TELERUTTORI CONTACTORS

4

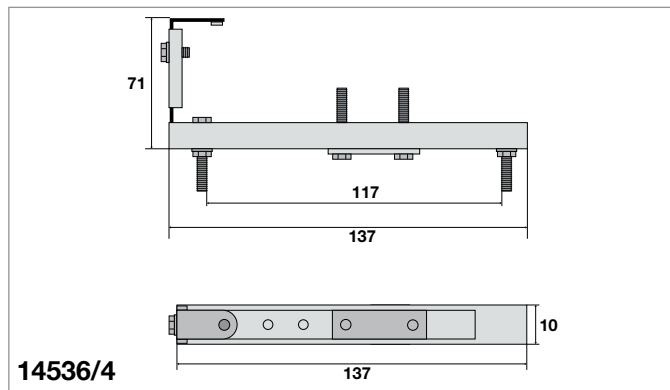
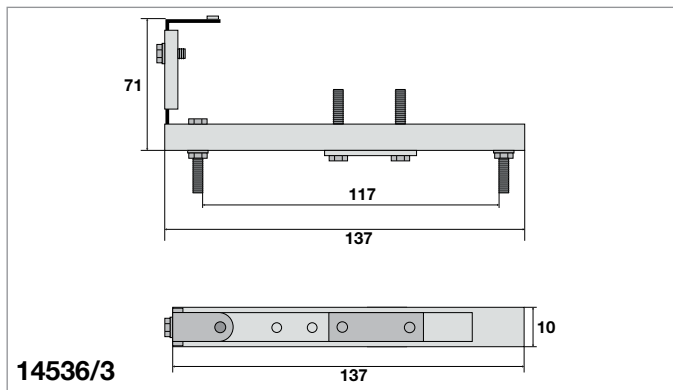
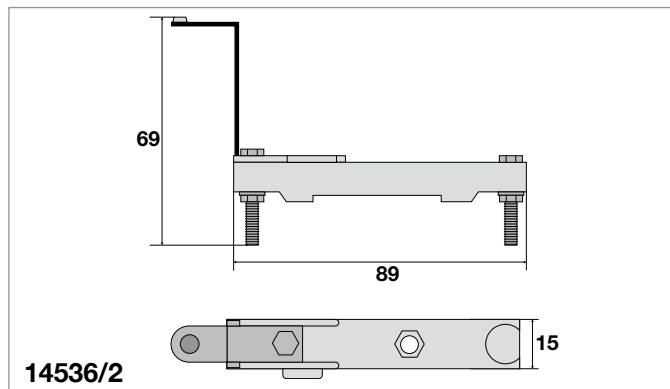
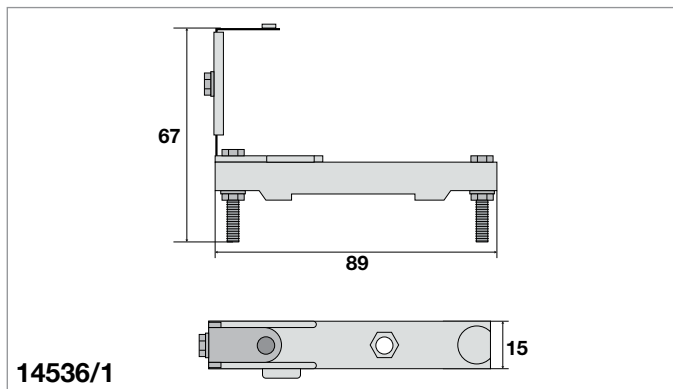
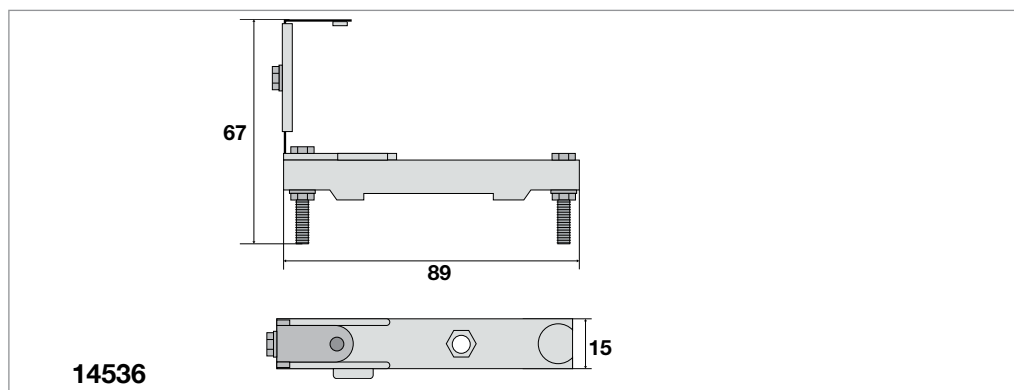
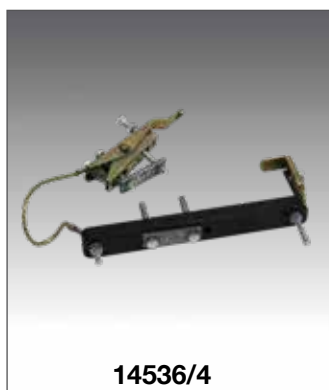
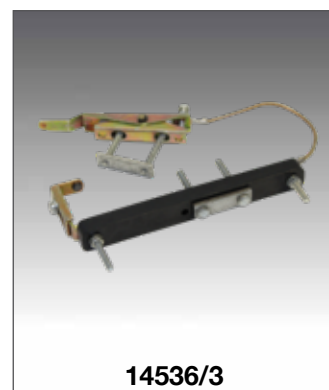

Codice / Code	Descrizione
14536	Teleruttore NF 41 FIAM con contatto ausiliario in apertura
14536/1	Teleruttore NF 41 FIAM con contatto ausiliario in chiusura
14536/2	Teleruttore NF 41 FIAM polo di forza motrice
14536/3	Teleruttore AGF80 - AGF200 FIAM con contatto ausiliario in chiusura
14536/4	Teleruttore AGF80 - AGF200 FIAM con contatto ausiliario in apertura

RELE RELAYS

4



14536/27/O - /U



14536/28/O - /U



14536/30

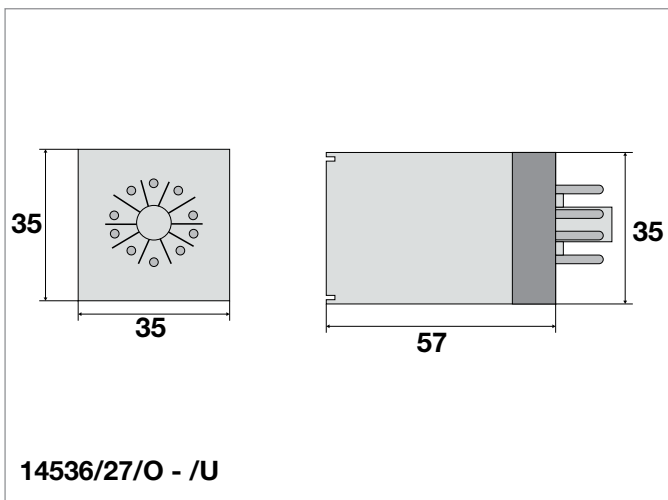

14536/27/O - /U

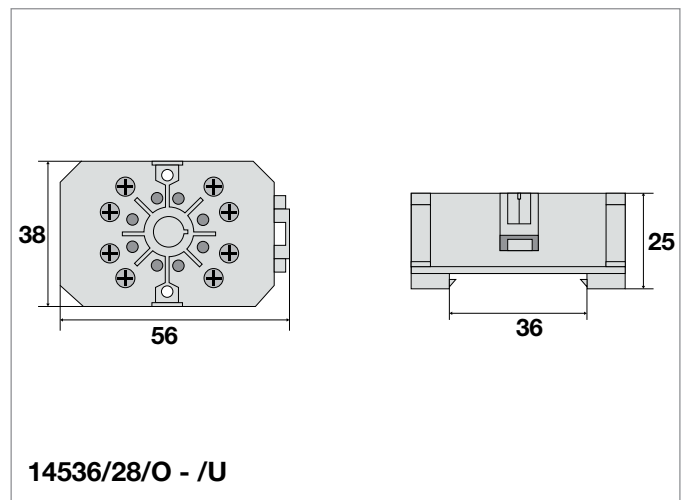

14536/28/O - /U

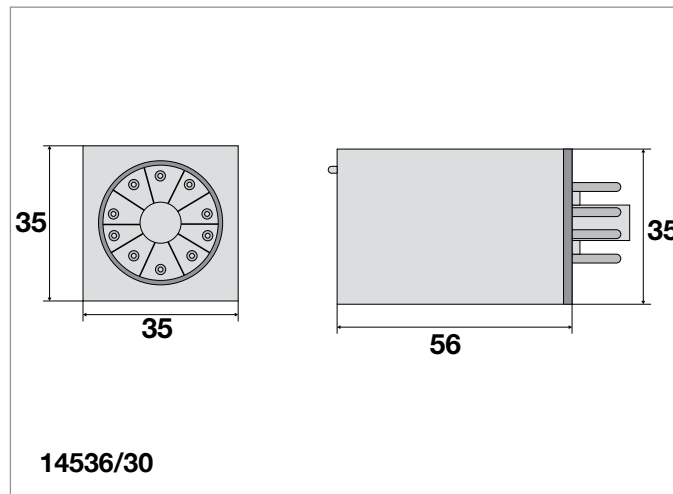

14536/30

Codice / Code	Descrizione
14536/27/O OCTAL	Relè OCTAL 220V - 24V - 12V specificare
14536/27/U UNDECAL	Relè UNDECAL 220V - 24V - 12V specificare
14536/28/O OCTAL	Zoccoli per relè OCTAL
14536/28/U UNDECAL	Zoccoli per relè UNDECAL
14536/30	Relè temporizzatore FIAM 60V. AC. DC. 5A. 250V. AC tipo EI981 da 6 a 180

RELÈ RELAYS

4

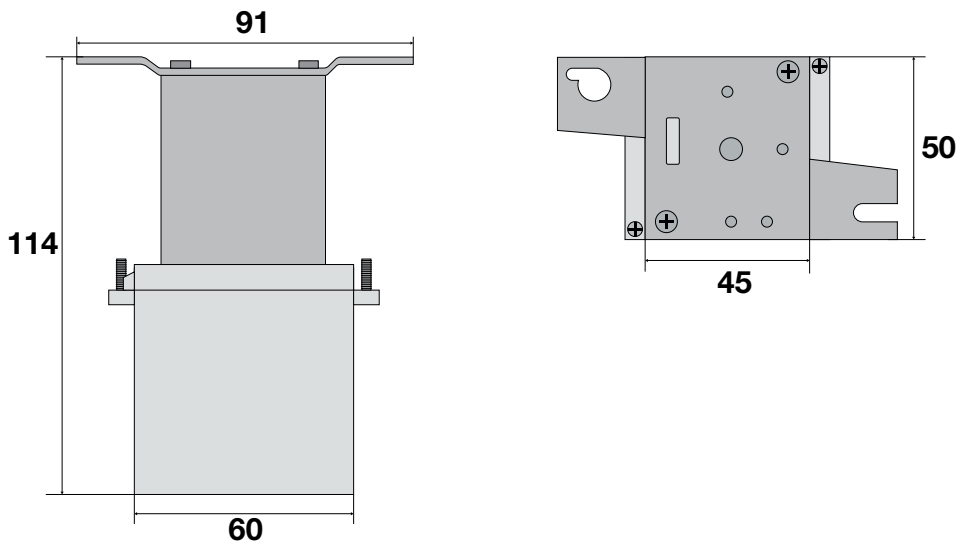

14920

Codice / Code	Descrizione
14908	Relè di piano SCHINDLER
14909	Relè ritardatore SCHINDLER
14920	Relè d'apertura SCHINDLER MRG 22 80V
14921	Relè d'apertura SCHINDLER MRG 62 80V
14922	Relè d'apertura SCHINDLER MRG 31 80V
14923	Relè d'apertura SCHINDLER MRG 44 80V

RESISTENZE RESISTORS

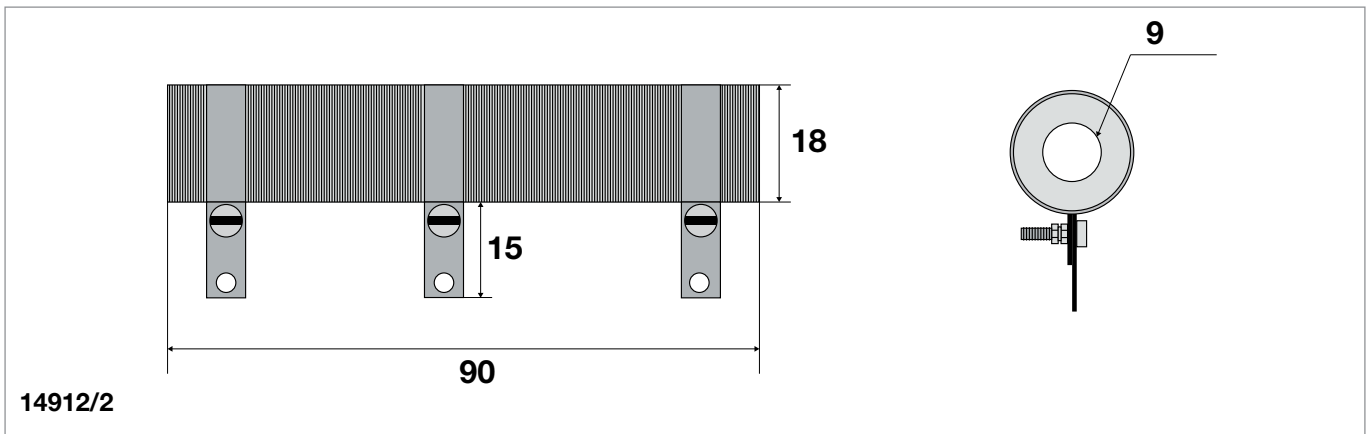
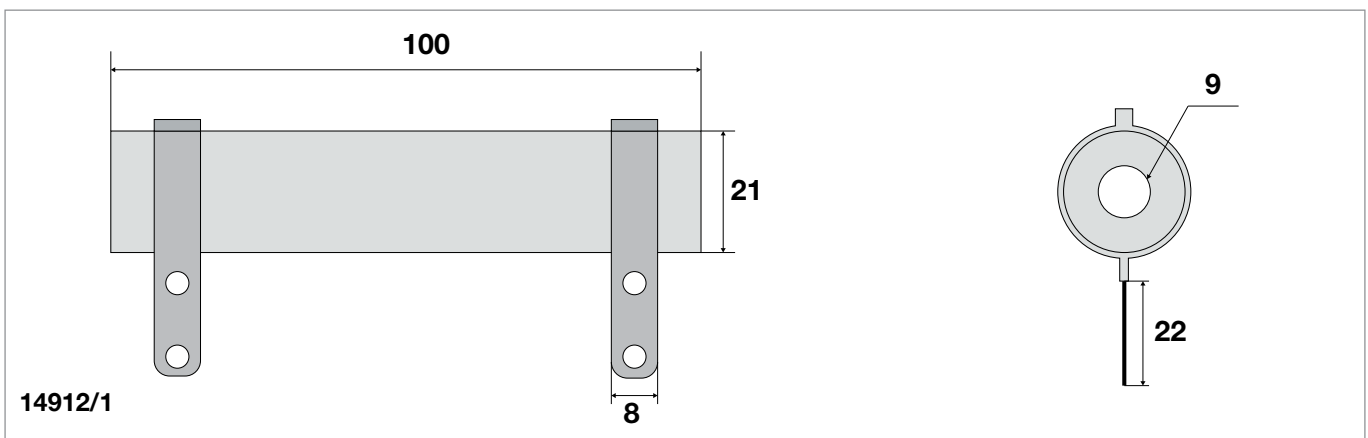

Resistenze Regolabili

Codice 14912/1*	A	B	C	D	E	F	G	H	I	L	M	N	O	P	Q
Watt	100	100	100	100	100	35	1500	1500	1500	1500	1500	1500	1500	1500	1500
OHM	15	30	40	300	1000	5	1,5	2	2,5	5	7,5	10	15	20	0,2

Resistenze non Regolabili

Codice 14912/2*	A	B	C	D	E	F	G	H	I	L	M
Watt	45	45	45	100	100	100	100	20	45	25	45
OHM	15	30	40	300	1000	5	1,5	2	2,5	5	7,5

* Aggiungere di seguito al codice la lettera relativa alla tipologia di resistenza (esempio: 14912/1P - 14912/2M)

RESISTENZE RESISTORS

4

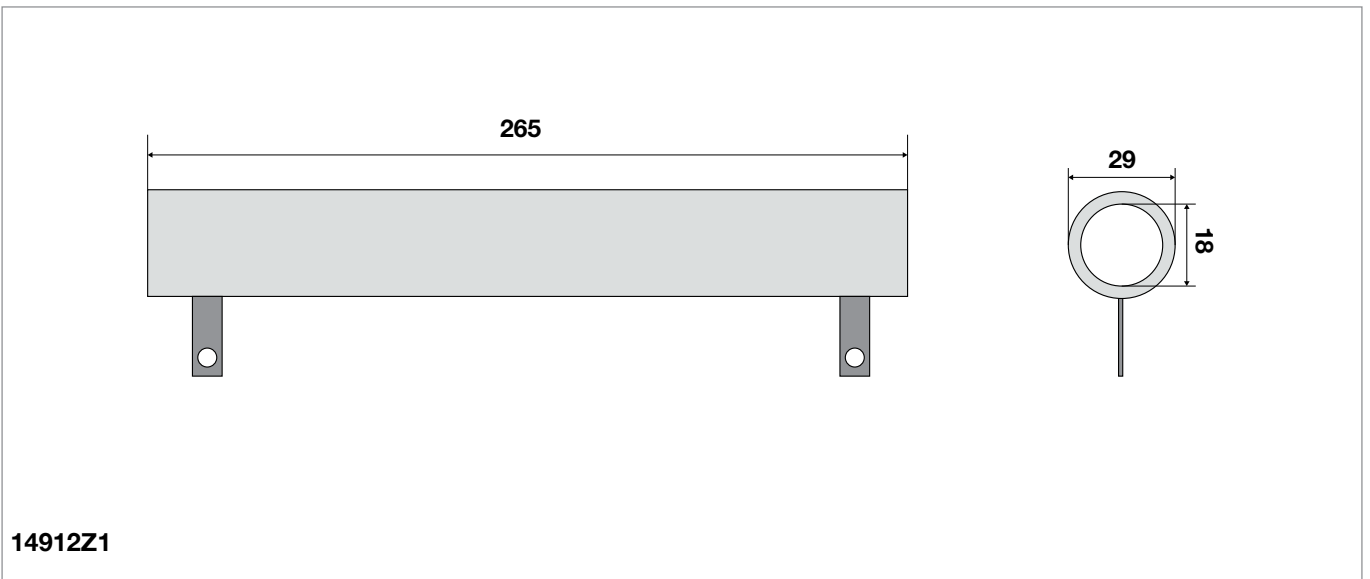
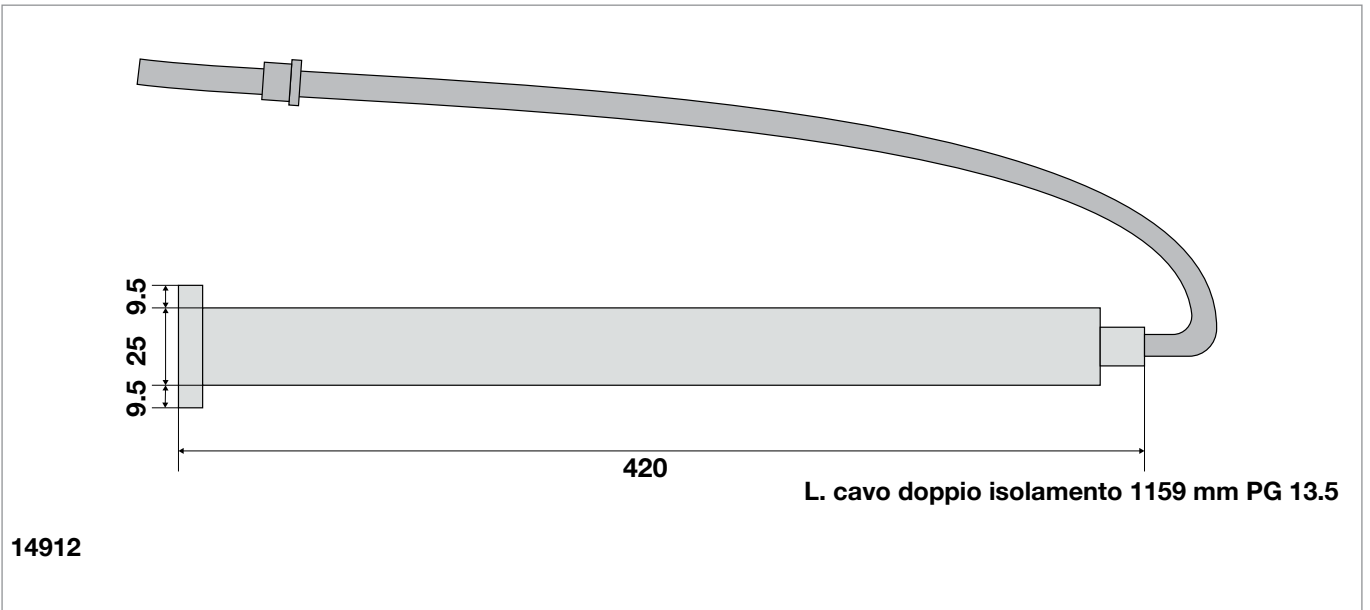

Codice / Code	Descrizione
14912	Resistenza riscalda olio non regolabile 230V. 500W
14912Z1	Resistenza non regolabile 1K Ω

ZENAMIC ZENAMIC

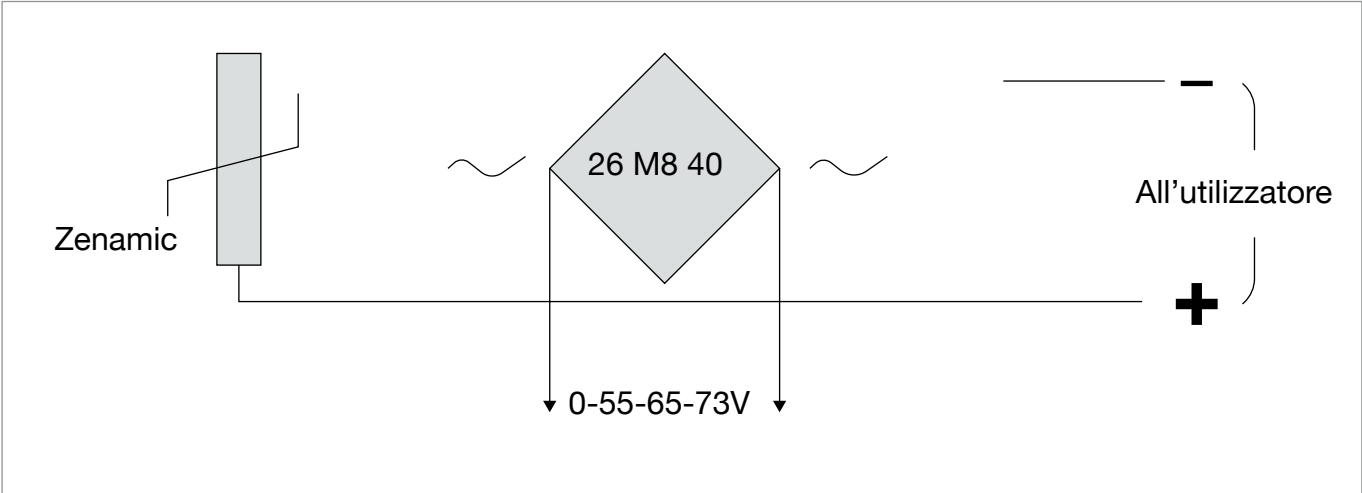
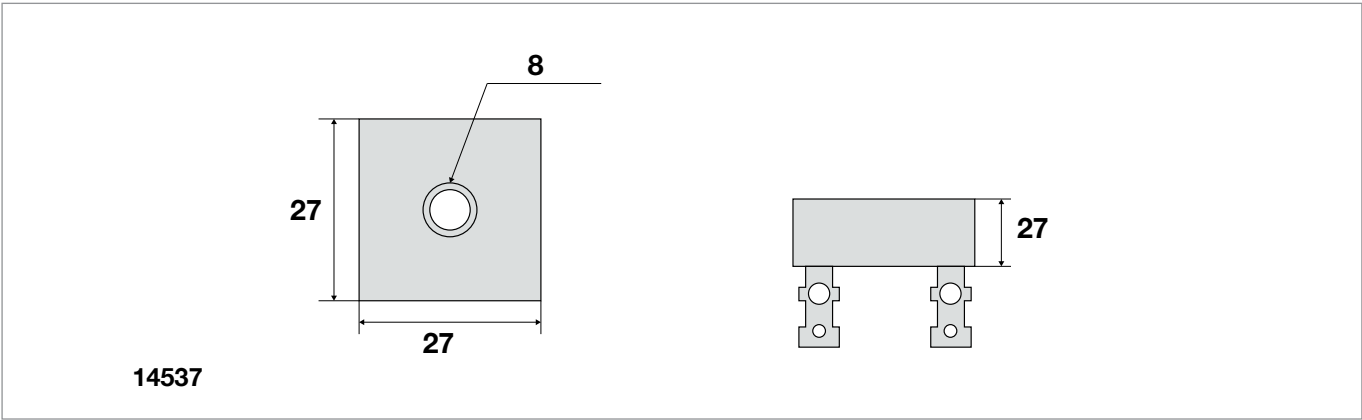

Schema per la sostituzione del raddrizzatore al silicio da 0,6A - 1,5A - 5A - 10A (vedi figura)
 Confezione occorrente composta da:
 Zenamic, ponte monofase, adattatore

Codice / Code	Descrizione
14537	Ponte monofase 25A 400 Volt
14537/1	Confezione Zenamic e capicorda

CONDENSATORI ELETTROLITICI ELECTRONIC CAPACITOR

4



Codice / Code	Descrizione
14536/33	Condensatore V.L.125 100 mf
14536/33A	Condensatore V.L.125 200 mf
14536/33B	Condensatore V.L.125 400mf
14536/33C	Condensatore V.L.125 800mf
14536/33D	Condensatore V.L.125 50mf
14536/33E	Condensatore V.L.125 0,068mf
14536/33F	Condensatore V.L.125 600mf
14536/33G	Condensatore V.L.125 1000mf

BOBINE - SPAZZOLE - TRASFORMATORI (SOLO SU ORDINAZIONE)
COILS - BRUSHES - TRANSFORMERS (ONLY ON DEMAND)

Bobina freno argano A100 - A200 - AO300 - A400 - AO400 BASSETTI	5.6
<i>Coil for BASSETTI brake winch A100 - A200 - AO300 - A400 - AO400</i>	
Bobina per teleruttore NF41 FIAM	5.4
<i>Coil for NF41 FIAM contactor</i>	
Bobina per teleruttore T05 - T06 FIAM	5.4
<i>Coil for FIAM contactor T05 - T06</i>	
Bobina per teleruttore TL4430 40A	5.6
<i>Coil for contactor TL4430 40A</i>	
Bobina per teleruttore STAHL 6573 - AGF65/80.....	5.5
<i>Coil for STAHL 6573 - AGF65/80 contactor</i>	
Bobina per teleruttore e ritardatore quadro SCHINDLER	5.8
<i>Coil for SCHINDLER contactor and delay boards</i>	
Bobina per teleruttore OTIS	5.9
<i>Coil for contactor OTIS</i>	
Bobina per pattino elettromagnetico LG46 - LG47 - LG47/1 FIAM	5.4
<i>Coil for electromagnetic guide shoe LG46 - LG47 - LG47/1 FIAM</i>	
Bobina per valvole centralina FIAM	5.4
<i>Coil for FIAM junction box fuse</i>	
Bobina per contattore LOVATO	5.4
<i>Coil for LOVATO contactor</i>	
Bobina per relè 48V BASSETTI	5.6
<i>Coil for BASSETTI relay 48V</i>	

Bobine per relè OTIS	5.10-5.11
<i>Coil for relay OTIS</i>	
Bobina per relè FIAM	5.4
<i>Coil for FIAM relay</i>	
Bobina per quadri a pattini retrattili OTIS	5.11-5.12
<i>Coil for OTIS boards and retiring cam</i>	
Bobina per quadri FALCONI	5.13
<i>Coil for FALCONI boards</i>	
Bobina per elettromagnete freno argano FIAM	5.5
<i>Coil for FIAM electromagnet brake winch</i>	
Bobina per freno argano, per pattino retrattile SAFOV	5.13
<i>Coil for SAFOV boards, brake winch and retiring cam</i>	
Bobina SABIEM per freno argano F164 - F224	5.7
<i>Coil for SABIEM brake winch F164 - F224</i>	
Bobina teleruttore NF41 FIAM	5.4
<i>Coil for FIAM contactor NF41</i>	

SPAZZOLE
BRUSHES

Spazzole motori FIAM	5.14
<i>Brushes for FIAM motors</i>	
Spazzole motori FALCONI	5.14
<i>Brushes for FALCONI motors</i>	
Spazzole motori OTIS	5.14 - 5.15
<i>Brushes for OTIS motors</i>	

TRASFORMATORI
TRANSFORMERS

Trasformatore monofase	5.16
<i>Single phase transformer</i>	
Trasformatore trifase e trimonofase trifase e trimonofase FIAM	5.17
<i>FIAM three phase and three-single phase transformers</i>	
Trasformatore trifase intercambiabile SCHINDLER	5.18
<i>SCHINDLER three phase transformers interchangeable</i>	
Trasformatore trifase intercambiabile OTIS	5.18
<i>OTIS three phase transformers interchangeable</i>	
Trasformatore monofase - trifase - trimonofase intercambiabile BASSETTI	5.18
<i>BASSETTI single phase transformers - three phase interchangeable</i>	

Note: I componenti sul catalogo con riportata una specifica marca di ascensore sono utilizzati abitualmente solo da questa marca. I particolari senza marca sono utilizzati da più marche di ascensori.

Note: *The components in the catalogue with a specific lift brand are usually used only by the brand. Unbranded parts are used by multiple lift brands.*

BOBINE FIAM FIAM COILS

5



14536/35-A-B-C



14536/35D



14536/35E-F-G-H



14536/35I



14536/36-37-38-39-40



14536/41A



14536/41B



14536/L0 14536/L1

Codice / Code	Descrizione
14536/35	Bobina per pattino elettromagnetico LG 47 LG47/1 48Vcc normale lunghezza B120 mm
14536/35A	Bobina per pattino elettromagnetico LG 47 LG47/1 24Vcc normale lunghezza B120 mm
14536/35B	Bobina per pattino elettromagnetico LG 47 LG47/1 60Vcc normale lunghezza B120 mm
14536/35C	Bobina per pattino elettromagnetico LG 47 LG47/1 220Vcc normale lunghezza B120 mm
14536/35D	Bobina per pattino elettromagnetico LG46 (lunghezza bobina 100mm) 48Vcc normale
14536/35E	Bobina per valvole centralina FIAM tensione 60Vcc F229M
14536/35F	Bobina per valvole centralina FIAM tensione 55Vcc F229M
14536/35G	Bobina per valvole centralina FIAM tensione 24Vcc F229M
14536/35H	Bobina per valvole centralina FIAM tensione 12Vcc F229M
14536/35I	Bobina teleruttore NF41
14536/36	Bobina per relè tipo 6/8C - 240/8000
14536/37	Bobina per relè tipo di piano - 320/9000
14536/38	Bobina per relè tipo RTA - 1850/20000
14536/39	Bobina per relè a tempo - 3000/25000
14536/40	Bobina per relè di piano 2C - 490/8000
14536/41A	Bobina per teleruttore T06
14536/41B	Bobina per teleruttore T05
14536/L0	Bobina per contattore Lovato tipo BA904 - 48VCC N° contatti BF9C - BF38C
14536/L1	Bobina per contattore Lovato tipo BA911 - 48VCC N° contatti B46C - B63C - B80C

BOBINE FIAM FIAM COILS



14536/34-A-B-C-D-E-F
G-H



14536/34I-L-N-O

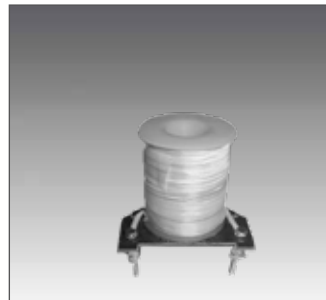

14536/43

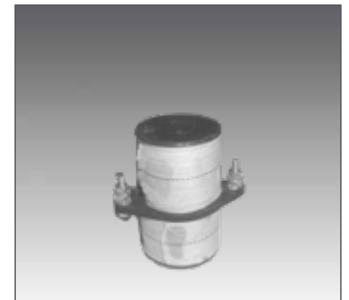

14536/44

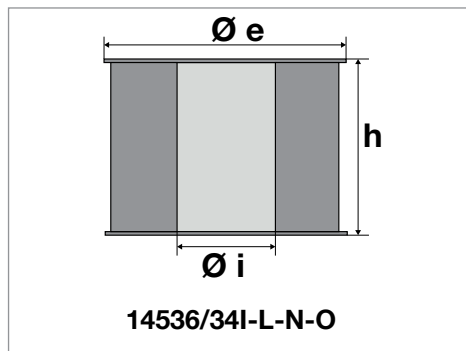
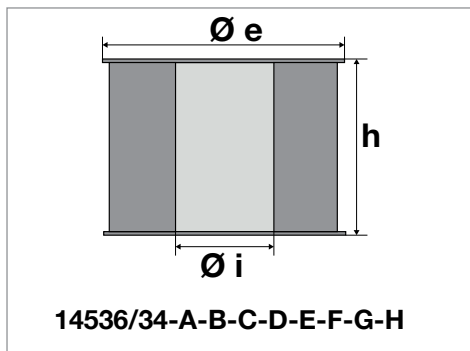

Codice / Code	Descrizione	Per argano tipo	Øe	Øi	h
14536/34	Bobina per elettromagnete freno argano	27 - 3N	100	42	78
14536/34A	Bobina per elettromagnete freno argano	5N	100	49	130
14536/34B	Bobina per elettromagnete freno argano	2N	100	42	78
14536/34C	Bobina per elettromagnete freno argano	25	84	49	78
14536/34D	Bobina per elettromagnete freno argano	26	84	49	78
14536/34E	Bobina per elettromagnete freno argano	5NR	100	49	130
14536/34F	Bobina per elettromagnete freno argano	55	100	56	120
14536/34G	Bobina per elettromagnete freno argano	6N/61	105	60	118
14536/34H	Bobina per elettromagnete freno argano	65	115	56	98
14536/34M	Bobina per elettromagnete freno argano	3N R	100	42	78

Codice / Code	Descrizione	Tipo di impiego	Øe	Øi	h
14536/34I	Bobina per elettromagnete freno argano	Freno d'emergenza con centralina KRIWAN 220V	100	49	78
14536/34L	Bobina per elettromagnete freno argano	Per motoriduttore con centralina KRIWAN 220V	100	56	120
14536/34N	Bobina per elettromagnete freno argano	Per motoriduttore MR1 48V	105	60	118
14536/34O	Bobina per elettromagnete freno argano	Per motoriduttore MR2 48V	100	56	120

Codice / Code	Descrizione
14536/43	Bobina per teleruttore STAHL 6573
14536/44	Bobina per teleruttore AGF65/80

BOBINE BASSETTI BASSETTI COILS

5



14650



14650/A



14650/B



14651-14651/1



14652

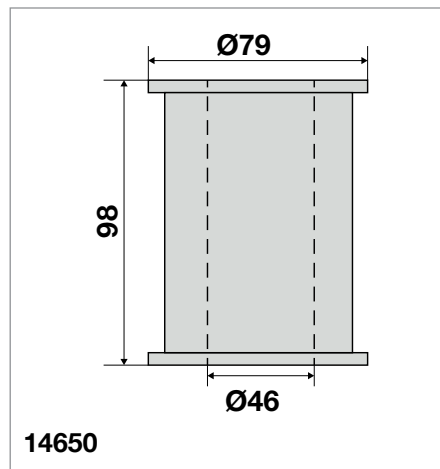

14650

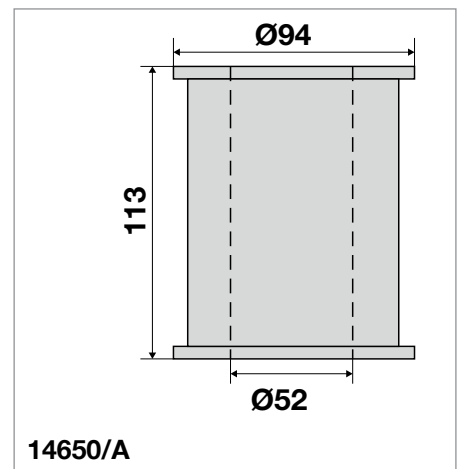

14650/A

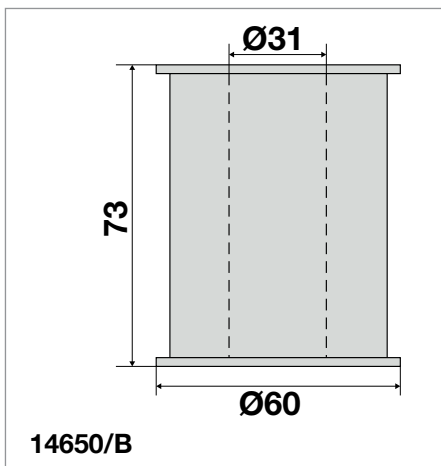

14650/B

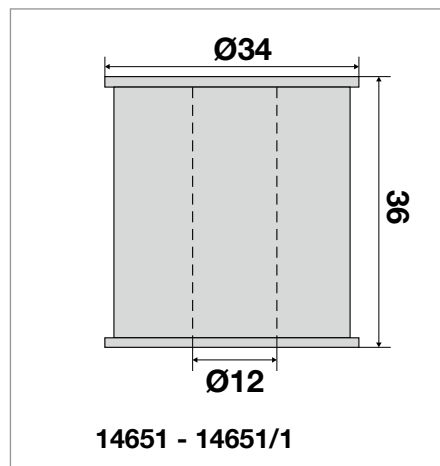

14651 - 14651/1

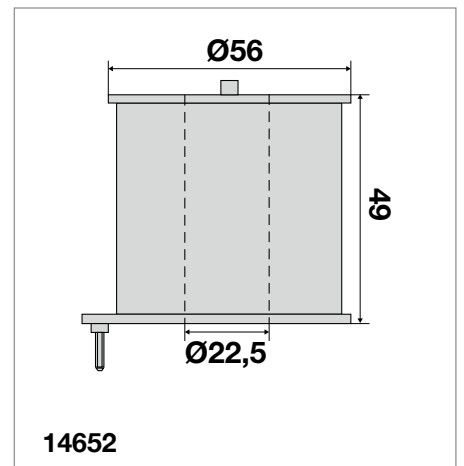

14652

Codice / Code	Descrizione
14650	Bobina freno Argano AO300
14650/A	Bobina freno Argano A400-AO400
14650/B	Bobina freno Argano A 100-A 200
14651-9500 spire	Bobina per relè 48V 9500 spire di piano
14651/1-22500 spire	Bobina per relè 48V 9500 spire temporizzato (su richiesta disponibili bobine da 22500 spire)
14652	Bobina per teleruttore TL4430 40-A

BOBINE SABIEM SABIEM COILS



5

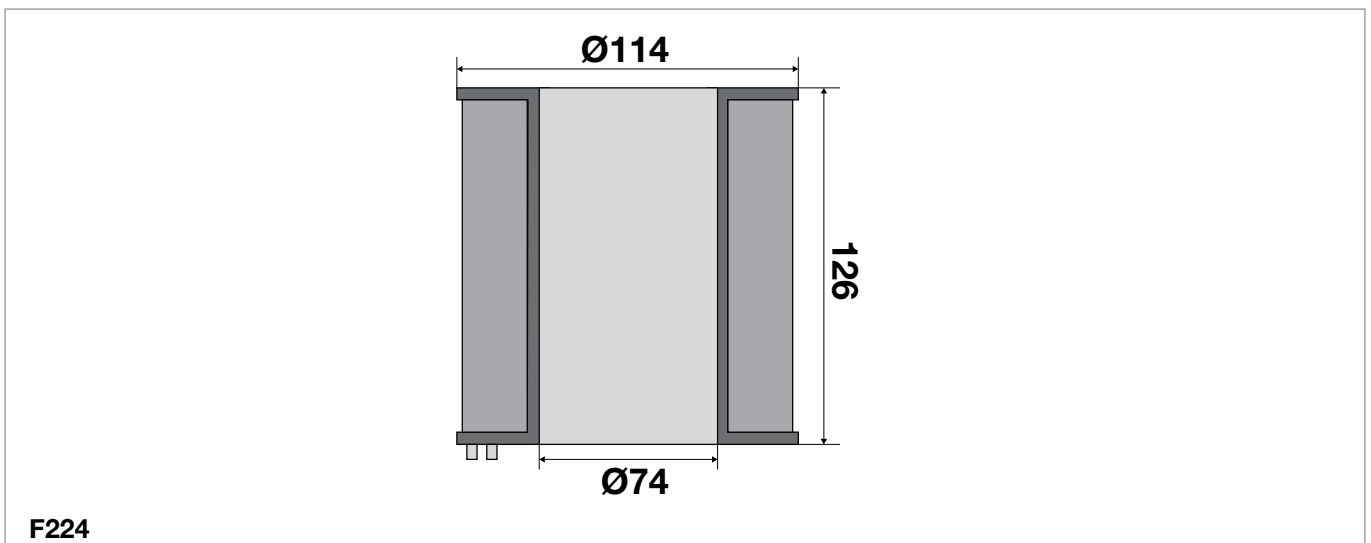
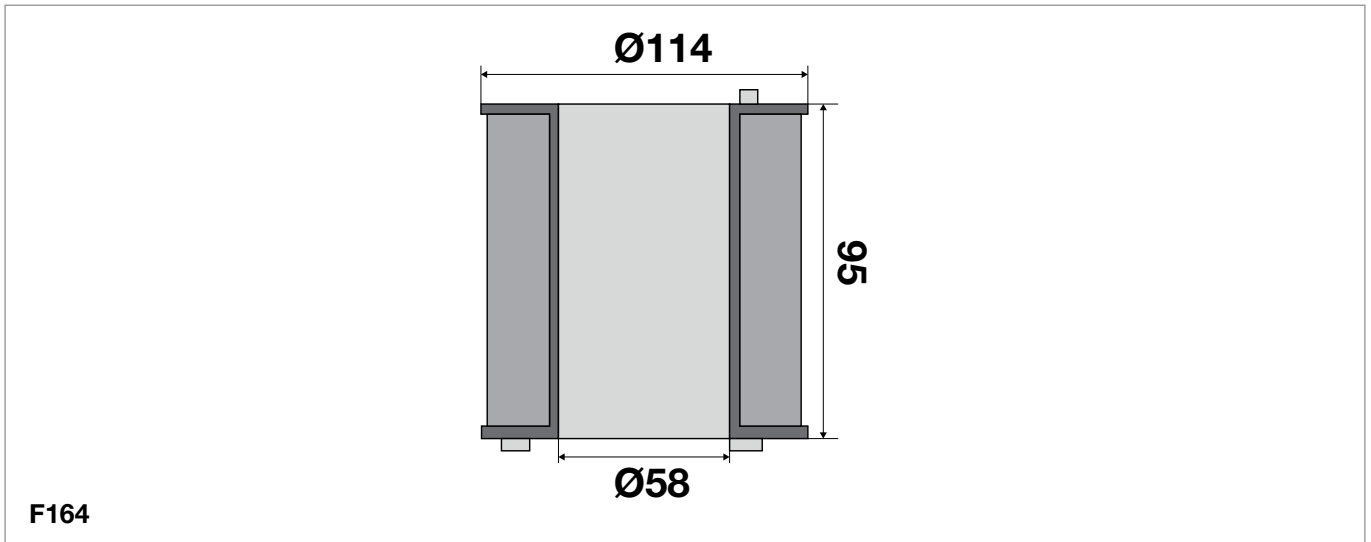

Codice / Code	Descrizione
F164	Bobina per freno Argano F164
F224	Bobina per freno Argano F224

BOBINE SCHINDLER SCHINDLER COILS

5

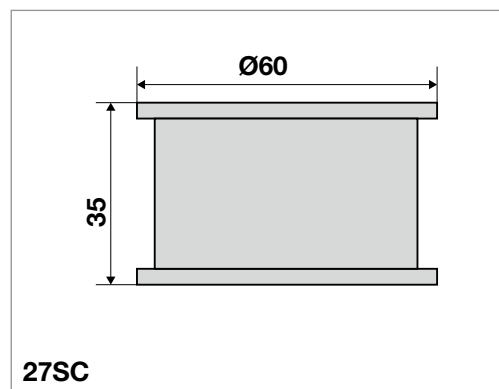
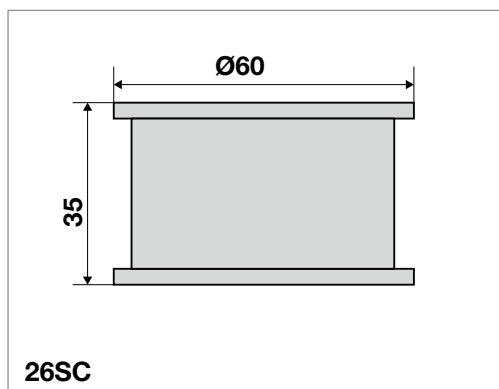

Codice / Code	Descrizione
26SC	Bobina per teleruttore RJ12 36V
27SC	Bobina per teleruttore RJ12 80V
28SC	Bobina per teleruttore RA 80V
29SC	Bobina per teleruttore RA 13V
30SC	Bobina per teleruttore RA 36V
31SC	Bobina per teleruttore MG8 36V
31SC/A	Bobina per teleruttore MRG44 80V
32SC	Bobina per teleruttore MG8 80V
33SC	Bobina per teleruttore MG6 80V
33SC/A	Bobina per teleruttore MG7 80V
34SC	Bobina per teleruttore MG5 80V
14910	Bobina per relè ritardatore

BOBINE OTIS OTIS COILS

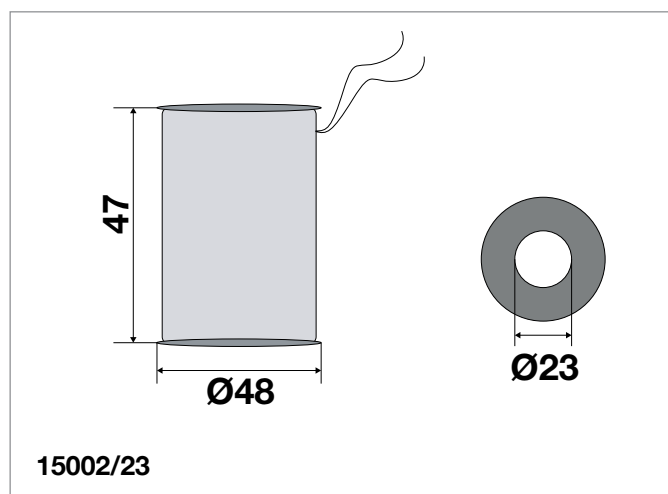
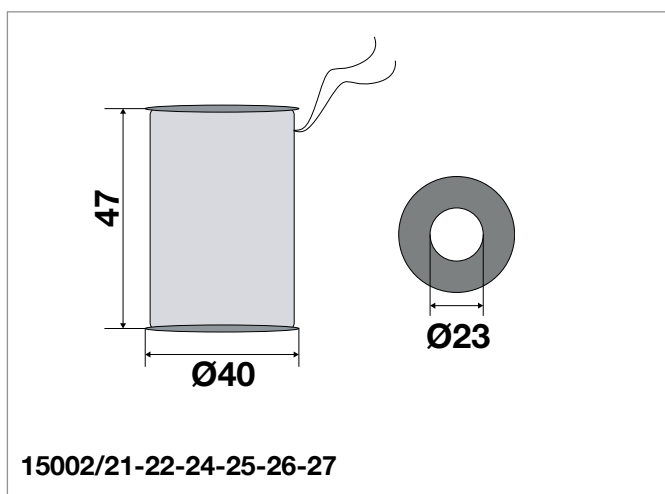

5

Codice / Code	Descrizione	Tipo
15002/21	Bobina per teleruttore (E6754)	222EB1
15002/22	Bobina per teleruttore (E6754)	222EB2
15002/23	Bobina per teleruttore (E6754)	222EB3
15002/24	Bobina per teleruttore (E6754)	222EB4
15002/25	Bobina per teleruttore (E6754)	222EB5
15002/26	Bobina per teleruttore (E6754)	222EB6
15002/27	Bobina per teleruttore (E6754)	222EB7

BOBINE OTIS OTIS COILS

5



15002



15002/2

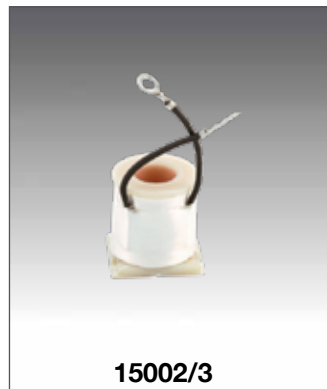

15002/3



15002/4



15002/5



15002/8

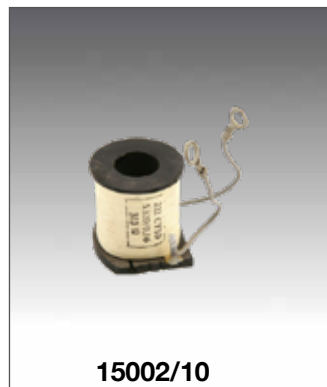

15002/10



15003



15003/2



15003/3



15003/5

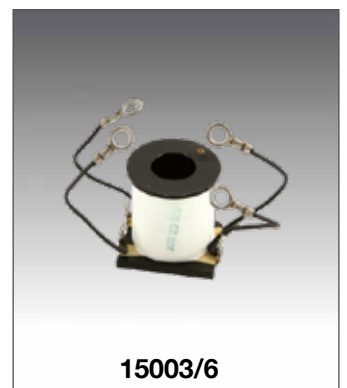

15003/6

Codice / Code	Descrizione
15002	Bobina per relè 222CY1 37 x Ø 36 x Ø 17 mm
15002/2	Bobina per relè 222CY2 37 x Ø 36 x Ø 17mm
15002/3	Bobina per relè 222CY3 37 x Ø 36 x Ø 17 mm
15002/4	Bobina per relè 222CY4 37 x Ø 36 x Ø 17 mm
15002/5	Bobina per relè 222CY5 37 x Ø 36 x Ø 17 mm
15002/8	Bobina per relè 222CY8 37 x Ø 36 x Ø 17 mm
15002/10	Bobina per relè 222CY10 37 x Ø 36 x Ø 17 mm
15003	Bobina per relè 222CZ1 37 x Ø 36 x Ø 17 mm
15003/2	Bobina per relè 222CZ2 37 x Ø 36 x Ø 17 mm
15003/3	Bobina per relè 222CZ3 37 x Ø 36 x Ø 17 mm
15003/5	Bobina per relè 222CZ5 37 x Ø 36 x Ø 17 mm
15003/6	Bobina per relè 222CZ504 37 x Ø 36 x Ø 17 mm

BOBINE OTIS OTIS COILS



15004

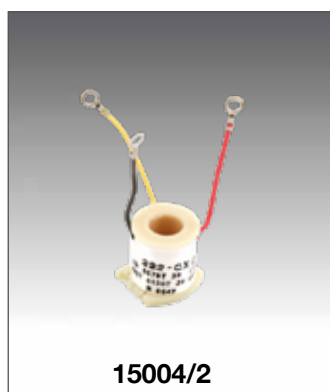

15004/2



15005-A-B



15007-A-B



15008



15009

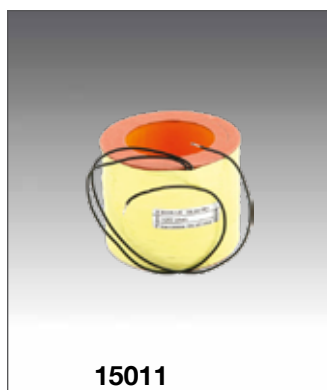

15011

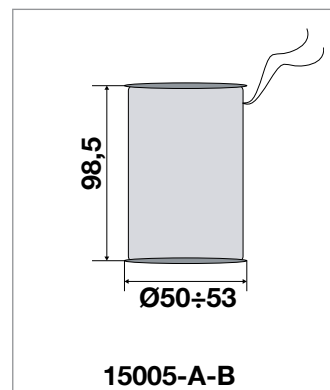

15005-A-B

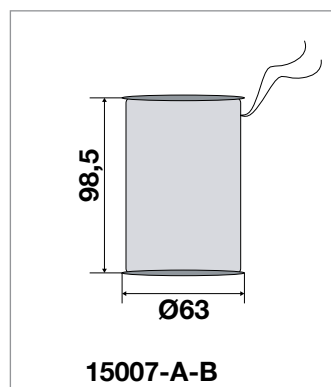

15007-A-B

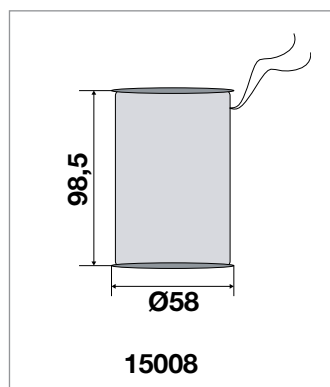

15008

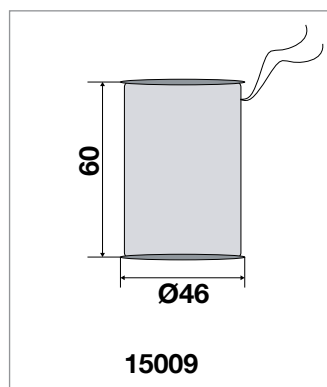

15009

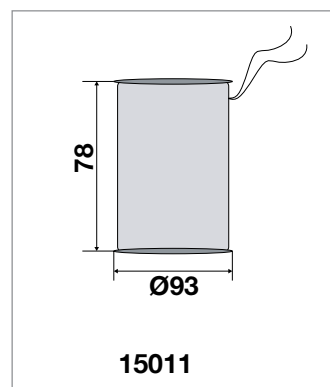

15011

Codice / Code	Descrizione	Tipo
15004	Bobina per relè 222CX1 37 x Ø 36 x Ø 17 mm	—
15004/2	Bobina per relè 222CX2 37 x Ø 36 x Ø 17 mm	—
15005	Bobina per pattino retrattile 90-105V	MO 222 DM 2
15005/A	Bobina per pattino retrattile 130V	MO 222 AE 1
15005/B	Bobina per pattino retrattile 110V	MO 222 AE 2
15007	Bobina per pattino retrattile 110V	MO 222 AF 2
15007/A	Bobina per pattino retrattile 110V	MO 222 AG 1
15007/B	Bobina per pattino retrattile 48V	MO 222 AF 3
15008	Bobina per pattino retrattile 110V	MO 222 AD 2
15009	Bobina OTIS 60 x Ø 46 x Ø 26 mm	222 DE 1
15011	Bobina OTIS 78 x Ø 93 x Ø 61mm	10 ATL
15012	Bobina OTIS	CM 20/12

BOBINE OTIS OTIS COILS

5

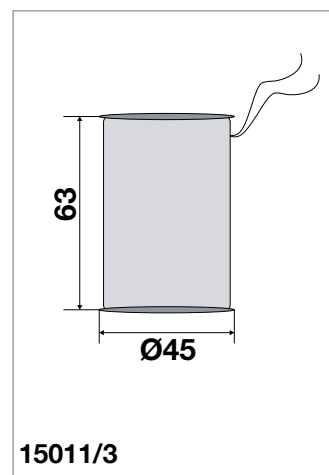
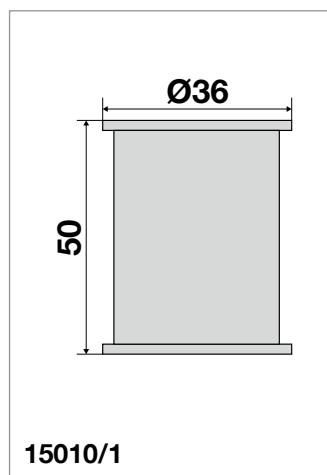
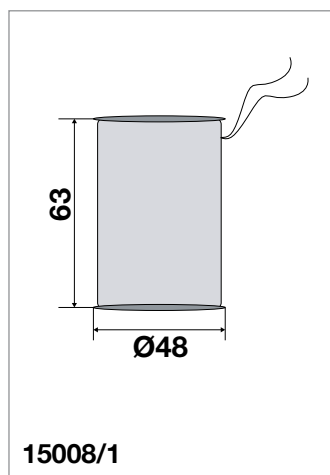
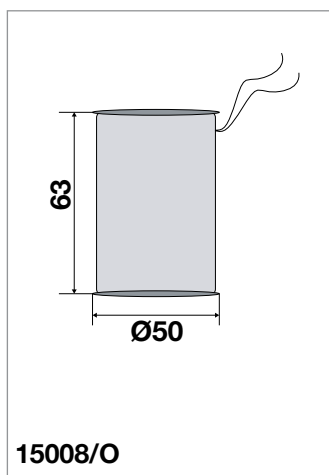
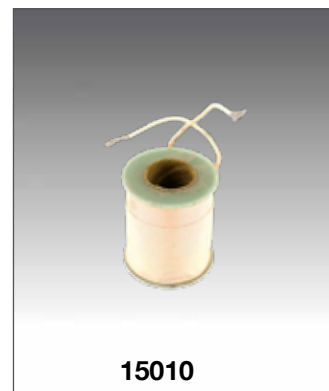

Codice / Code	Descrizione	Tipo
15008/O	Bobina OTIS	222 CV 2
15008/1	Bobina OTIS	222 CV 3
15008/2	Bobina OTIS	222 CV 4
15008/3	Bobina OTIS	222 CV 6
15010	Bobina OTIS BUMA 125V	222 Y 1
15010/1	Bobina OTIS BUMA 48V	222 Y2
15011/2	Bobina OTIS	222 BN 1
15011/3	Bobina OTIS	222 CV 1

BOBINE FALCONI E SAFOV FALCONI AND SAFOV COILS



5

Codice / Code	Descrizione	Tipo	Tensione
14071/1A	Bobina FALCONI	500.275.FG01	125 V
14071/1B	Bobina FALCONI	500.275.FG02	63 V
14071/1C	Bobina FALCONI	500.275.FG03	48 V
14071/1D	Bobina FALCONI	500.275.FG04	24 V
14071/1E	Bobina FALCONI	500.275.FG10	13,5 V
14071/1F	Bobina FALCONI	500.332.FG03	48 V
14071/1G	Bobina FALCONI	500.332.FG02	63 V
14071/1H	Bobina FALCONI	500.334.FG01	125 V
14071/1I	Bobina FALCONI	500.334.FG03L	48 V
14071/1L	Bobina FALCONI	500.333.FG01	125 V
14071/1M	Bobina FALCONI	500.333.FG02	48 V
14071/1N	Bobina FALCONI	500.346.FG02	125 V
14071/1O	Bobina FALCONI	500.346.FG02	48 V

Codice / Code	Descrizione
14850	Bobina relè collegamento in parallelo Vcc 24/47/40 specificare voltaggio SAFOV
14851	Bobina per freno SAFOV

Codice / Code	Descrizione
4007	Bobina SAFOV per elettromagnete codice 4000-4001-4002-4003-4004-4005-4006 Specificare voltaggio

SPAZZOLE BRUSHES

5



14536/41

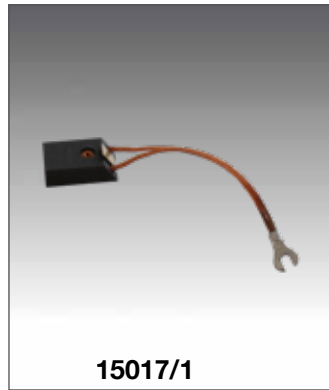

15017/1

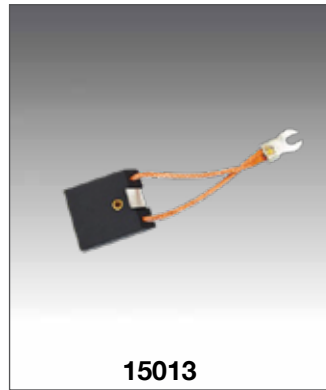

15013



15015

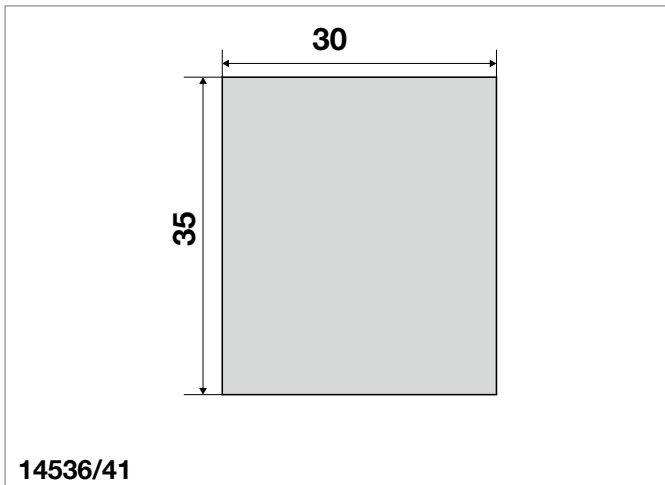

14536/41

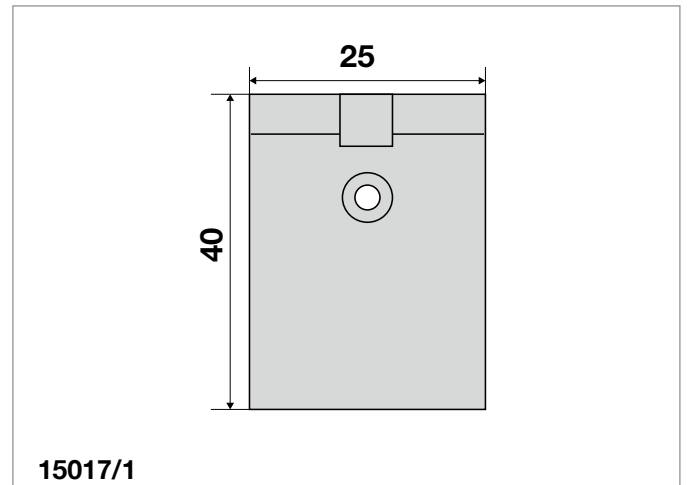

15017/1

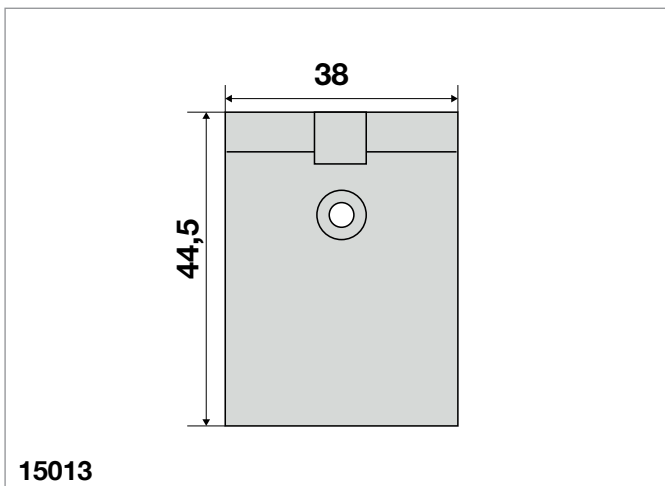

15013

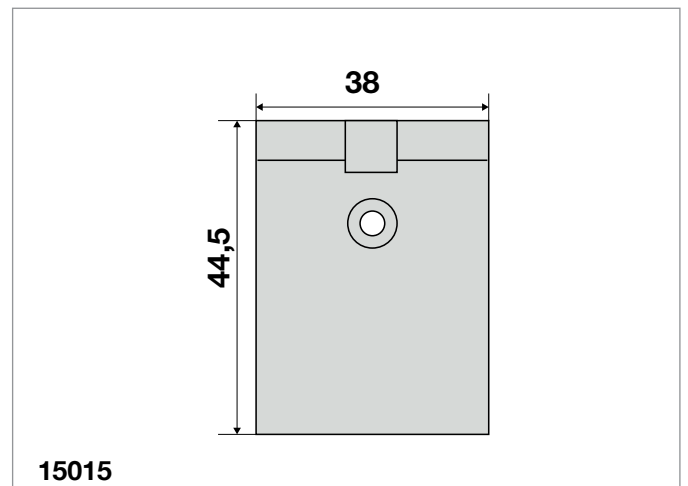

15015

Codice / Code	Descrizione
14536/41	Spazzole motori FIAM 30 x 35 x 10
14536/42	Spazzole motori FIAM 30 x 35 x 15
15017/1	Spazzole motori FALCONI 40 x 25 x 12,5
15013	Spazzola OTIS tipo 240 P3
15014	Spazzola OTIS tipo 240 J 1
15015	Spazzola OTIS tipo 240 J 2
15016	Spazzola OTIS tipo 240 J 3

SPAZZOLE BRUSHES

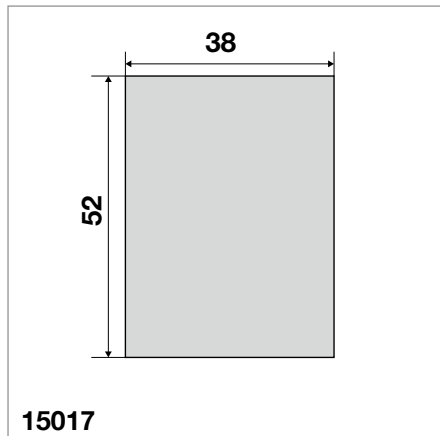
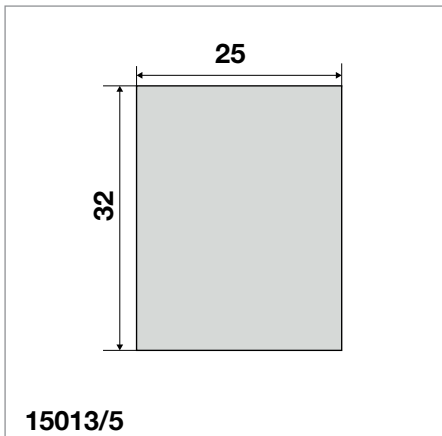
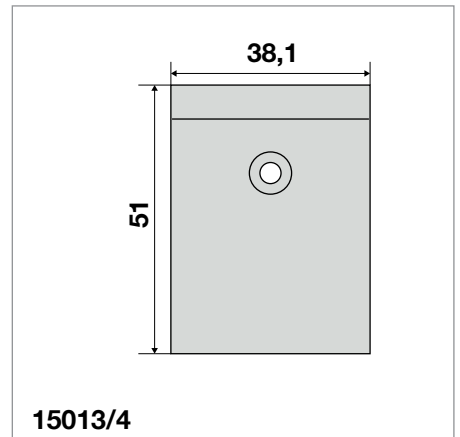
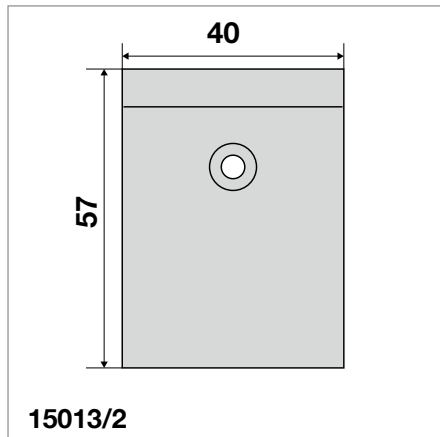
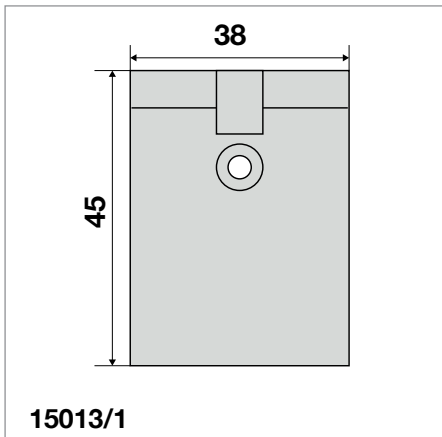

Codice / Code	Descrizione
15013/1	Spazzola OTIS tipo 240 P2 65 GAL
15013/2	Spazzola OTIS per motore 240AA 4 GENE (L) 71GA - 95GB - 115GB + 2B 3B
15013/3	Spazzola OTIS per motore 240AA 3 GENE 2B/3B/95GB/115GB
15013/4	Spazzola OTIS per motore 240 R1 GENE (L) 71/82 GA
15013/5	Spazzola OTIS 25 x 32 x 8
15013/7	Spazzola OTIS per motore 240AA 3 GENE 2B/3B/95GB/115GB
15013/8	Spazzola OTIS per motore 240AA 3 GENE 2B/3B/95GB/115GB
15013/9	Spazzola OTIS per motore 240 R1 GENE (L) 71/82 GA
15017	Spazzola OTIS tipo 240 R1

TRASFORMATORI MONOFASE SINGLE PHASE TRANSFORMERS



5

Potenza V.A	Tensione primaria	Tensione secondaria
200/3	0/125/220/380	0/6/22/24
200/3	0/208/346/415	0/6/22/24
250/1	0/208	0/55/65/73-0/6/20/22
250/1	0/220	0/55/65/73-0/6/20/22
250/1	0/346	0/55/65/73-0/6/20/22
250/1	0/380	0/55/65/73-0/6/20/22
250/1	0/415	0/55/65/73-0/6/20/22
250/1	0/500	0/55/65/73-0/6/20/22
250/4	0/220/346/380/415	0/55/65/73-0/6/20/22
350/1	0/190	0/55/65/73-0/6/20/22
350/1	0/280	0/55/65/73-0/6/20/22
350/1	0/220	0/55/65/73-0/6/20/22
350/1	0/346	0/55/65/73-0/6/20/22
350/1	0/380	0/55/65/73-0/6/20/22
350/1	0/415	0/55/65/73-0/6/20/22
350/1	0/500	0/55/65/73-0/6/20/22
350/4	0/220/346/380/415	0/55/65/73-0/6/20/22
550/1	0/208	0/55/65/73-0/6/20/22
550/1	0/220	0/55/65/73-0/6/20/22
550/1	0/346	0/55/65/73-0/6/20/22
550/1	0/380	0/55/65/73-0/6/20/22
550/1	0/415	0/55/65/73-0/6/20/22
550/1	0/500	0/55/65/73-0/6/20/22
540/4	0/220/346/380/415	0/55/65/73-0/6/20/22
800/1	0/208	0/55/65/73-0/6/20/22
800/1	0/220	0/55/65/73-0/6/20/22
800/1	0/346	0/55/65/73-0/6/20/22
800/1	0/380	0/55/65/73-0/6/20/22

TRASFORMATORI TRIFASE E TRIMONOFASE THREE PHASE - THREE - SINGLE PHASE TRANSFORMERS

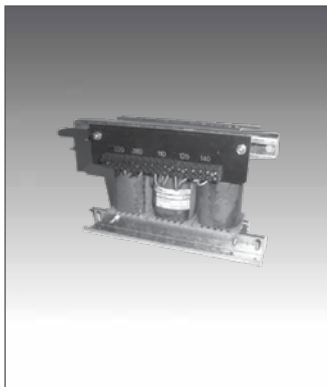

Potenza V.A	Tensione primaria	Tensione secondaria
500	380	125
500	220/380	0/65/73 - 125/0/6
500	280/380	110/125/140
500	380	0/65/73 - 125/8/022
800	220/380	48/125/140/0/6
800	346/415	125/140/200
800	208	150/170
800	260/380	125/220

TRASFORMATORE MONOFASE SPECIFICI FIAM SINGLE PHASE TRANSFORMERS FOR SPECIFIC FIAM

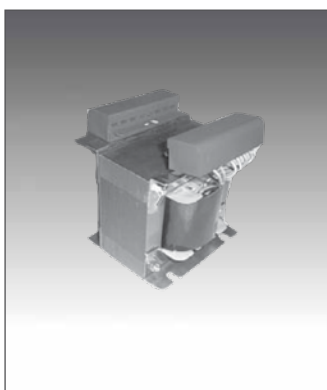

Potenza V.A	Tensione primaria	Tensione secondaria
30/1	0/65	9/0/9 - 0/14/17
30/4	0/220/346/380/415	9/0/9 - 0/14/17
30/5	0/208/220/346/380/415	0/4/6/8/10
50/3	0/200/220/240	0/6/22/24
50/3	0/125/220/380	0/65/73 - 0/6/20/22
50/4	0/220/346/380/415	0/220
100/4	0/220/346/380/415	0/20/22
150/4	0/220/346/380/415	0/65/73 - 0/20/22

TRASFORMATORE TRIFASE INTERCAMBIABILE SCHINDLER INTERCHANGEABLE THREE PHASE TRANSFORMER SCHINDLER



5

Codice / code	Potenza V.A	Tensione primaria	Tensione secondaria
14911	550	220/380	0/23-0/96 - 96

TRASFORMATORE TRIFASE INTERCAMBIABILE OTIS THREE PHASE TRANSFORMER INTERCHANGEABLE OTIS



Codice / code	Descrizione
14911/A	Alimentazione 550Va
	Alimentazione 250Va

TRASFORMATORE MONO TRIMONOFASE INTERCAMBIABILE BASSETTI SINGLE PHASE TRANSFORMERS INTERCHANGEABLE BASSETTI



Codice / code	Potenza V.A	Tensione primaria	Tensione secondaria
14911/B	750	220/380	95-110-125, 0/10 - 0/60-70-80 - 0/115
	550	220/380	95-110-125, 0/10 - 0/60-70-80 - 0/115
	550	220/380	95-110-125, 0/10 - 0/60 - 70 - 80
	550	220/380	95-110-125, 0/10 - 0/60 - 70 - 80

COMPONENTI DIVERSI PER OPERATORI E SOSPENSIONI, GANCI, SCIVOLI, SCATOLE DI AGGANCIAMENTO, BIELLA DISPOSITIVO DI SGANCIO, SERRATURE PER PORTE SCORREVOLI, CAMME OPERATORE, CARTER OPERATORE OTIS

DIFFERENT COMPONENTS FOR OPERATORS AND HANGER, HOOK, VANE CAM, HOOK BOX, ROD FOR UNFASTEN SYSTEM, DOOR LOCK FOR SLIDING DOOR, CAM OPERATOR, OPERATOR FRAME OTIS

Automatismo FIAM A/2PO + Pezzi di ricambio	6.13
<i>FIAM A/2PO operator + spare parts</i>	
Biella dispositivo da gancio operatore FIAM con suoi componenti	6.12
<i>Connection rod of hook operator device FIAM with its components</i>	
Bielletta per assieme camma e scivolo di abbinamento operatore SCHINDLER QKS 8 - QKS 9	6.7- 6.8 - 6.9
<i>Rod for assembling cam and vane operator coupling SCHINDLER QKS 8 - QKS 9</i>	
Camma Operatore OTIS 6850	6.21
<i>Operator Cam OTIS 6850</i>	
Camma operatore FIAM motoriduttore tipo MR041	6.16
<i>Operating cam for motor reducer MR041 FIAM</i>	
Controleva catenaccio sospensioni di piano contro leva destra e sinistra	6.19
<i>Lock lever hanger for landing door in right and left</i>	
Fermo porta operatori FALCONI adattabili OTIS DX e SX	6.22
<i>FALCONI operator door stop suitable for OTIS Right and Left</i>	
Ganci sospensioni con e senza molla IGV	6.23
<i>Hanger hook with or without spring IGV</i>	
Gancio blocco operatore SABIEM	6.18
<i>Block hook for operator SABIEM</i>	
Gancio di blocco sospensione SCHINDLER e suoi componenti QKSM2	6.4
<i>SCHINDLER locking clamp hanger and its QKSM2 components</i>	
Gommino paracolpi ricambi operatore OTIS 9550CC	6.21
<i>Bumper for operator OTIS 9550CC</i>	
Leva aggancio sospensione FIAM B2PT (destra e sinistra)	6.17
<i>Lock lever for FIAM B2PT header (right and left)</i>	
Leva comando catenaccio per sospensioni FIAM tipo S (DX - SX)	6.16
<i>Lock actuating lever hanger for FIAM tipo S (Right - Left)</i>	

Leva di aggancio DX e SX per sospensione A/2PO FIAM	6.11
<i>Lever of hook right and left for FIAM A/2PO hanger</i>	
Leva di aggancio per operatore FIAM A/2PO	6.15
<i>Lever of hook for FIAM A/2PO operator</i>	
Leva galoppino tendicinghia per operatore FIAM tipo S	6.16
<i>Belt tightener lever for operator FIAM type S</i>	
Leva gancio A.O.OTIS Orly 9940 (a richiesta) SX e DX	6.21
<i>Hook lever A.O.OTIS Orly 9940 (on request) Left and Right</i>	
Leva gancio blocco operatore SABIEM con supporto	6.18
<i>Lever hook for block SABIEM operator with support</i>	
Leva inferiore innesto operatore	6.19
<i>Lower lever for operator</i>	
Leva per operatori OTIS 9550T - 9550CC	6.21
<i>Lever for OTIS 9550T - 9550CC operators</i>	
Leva per sospensioni FIAM B/PT DX e SX.....	6.11
<i>Lever for hanger FIAM B/PT right and left</i>	
Leva superiore per operatore SABIEM	6.19
<i>Upper lever for operator SABIEM</i>	
Leve abbinamento porte automatiche SCHINDLER e componenti	6.5
<i>Lever for coupling SCHINDLER automatic doors and components</i>	
Operatore OTIS 9550 T (carter - mezzo ingranaggio - ingranaggio doppio - contatto per operatore OTIS - extracorsa - finecorsa)	6.20
<i>OTIS 9550 T operator (operator frame - plastic spur gear - drive sprocket - contact for OTIS operator - extra movement - limit switch)</i>	
Perno con carrucola operatore FIAM S/4PT eccentrico operatore porte automatiche FIAM tipo S e FORSID - MONITOR	6.10
<i>Pivot with pulley operator control FIAM S/4PT eccentric for automatic door operator FIAM type S and FORSID - MONITOR</i>	
Pulegge operatore BASSETTI	6.24
<i>Pulley for operator BASSETTI</i>	

Scatola controserratura in fusione per aggancio “leva gancio di blocco” SCHINDLER + copertura trasparente + gommino e componenti	6.5
<i>Safety counter lock fusion for SCHINDLER hook “lever of locking clamp” + transparent cover + rubber and components</i>	
Scivolo DX e SX carrello operatore FIAM S/2PT - S/4PT	6.14
<i>Contact chute and chain stretcher for FIAM S/2PT - S/4PT Right - Left</i>	
Scivolo per contatti automatismo FIAM A/2PO	6.15
<i>Contact chute for automatic contact FIAM A/2PO</i>	
Supporto contatti motoriduttore FIAM A2PO	6.15
<i>FIAM A2PO motor reducer contact support</i>	
Supporto per puntone operatore FIAM A/2PO	6.13
<i>Baffer support for FIAM A/2PO operator</i>	
Tendicatena e tendifune automatismo FIAM S/2PO - B/2PT	6.17
<i>Chain and rope stretcher for automatic door type FIAM S/2PT - B/2PT</i>	
Tendifune sospensione SCHINDLER	6.6
<i>SCHINDLER tensioner rope hanger</i>	

Note: I componenti sul catalogo con riportata una specifica marca di ascensore sono utilizzati abitualmente solo da questa marca. I particolari senza marca sono utilizzati da più marche di ascensori.

Note: The components in the catalogue with a specific lift brand are usually used only by the brand. Unbranded parts are used by multiple lift brands.

COMPONENTI SOSPENSIONE SCHINDLER QKSM2 PER BLOCCO MECCANICO
SCHINDLER QKSM2 HANGER COMPONENTS FOR LOCKING CLAMP

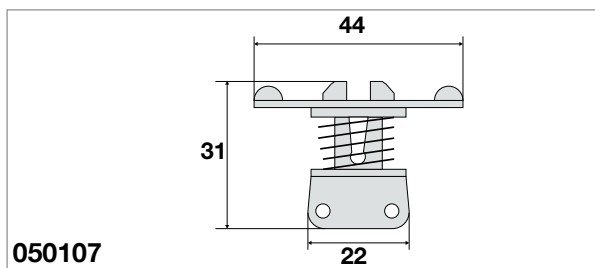
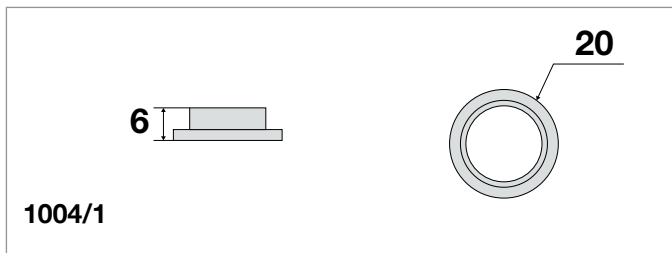
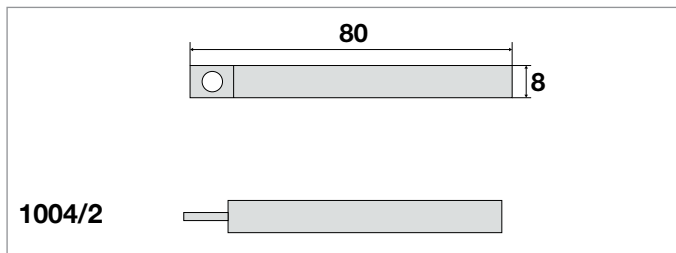
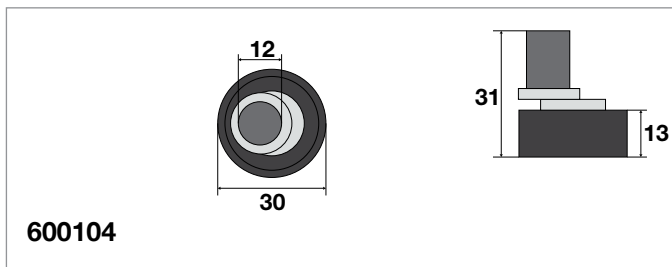
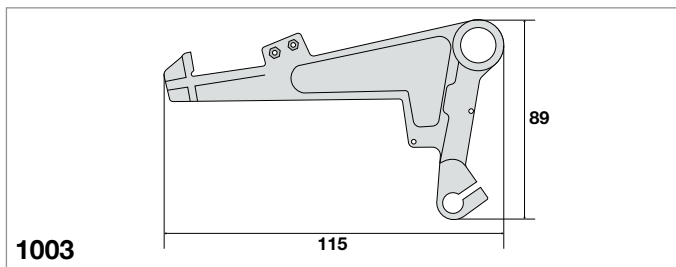
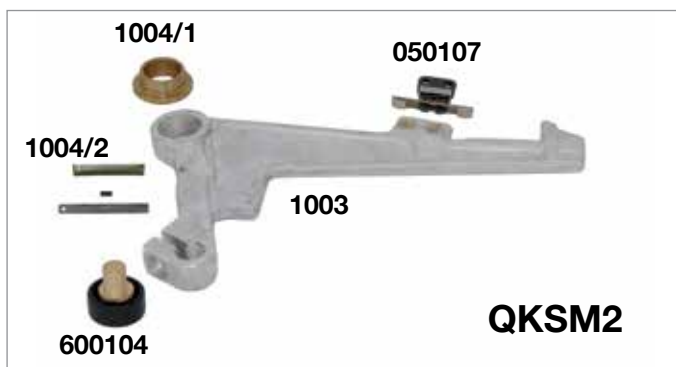

Codice / Code	Descrizione
1003	Catenaccio di blocco
1004/1	Boccola in bronzo
1004/2	Perno + molla + spina
600104	Rotella con perno ambidestra
600104/1	Solo rotella in gomma
050107	Ponte contatto

**SCATOLA PER SERRATURA E GANCI PER BLOCCO MECCANICO
SOSPENSIONE DI PIANO SCORREVOLE SCHINDLER
COUNTER DOOR LOCK AND HOOK FOR HANGER OF MECHANICAL BLOCK
IN SCHINDLER LANDING DOOR**

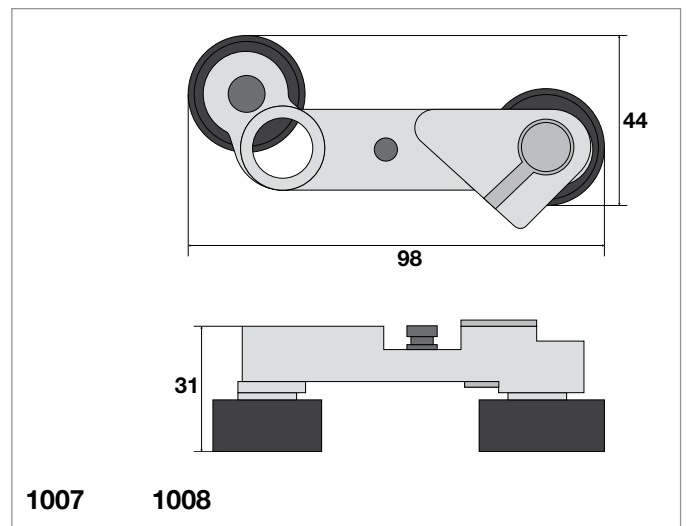
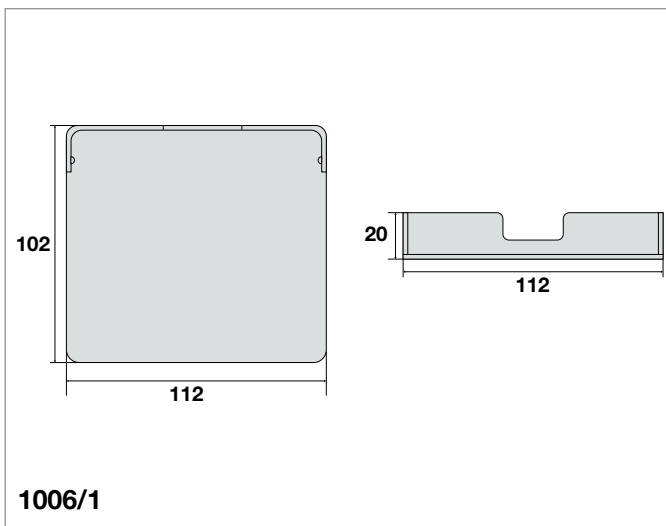
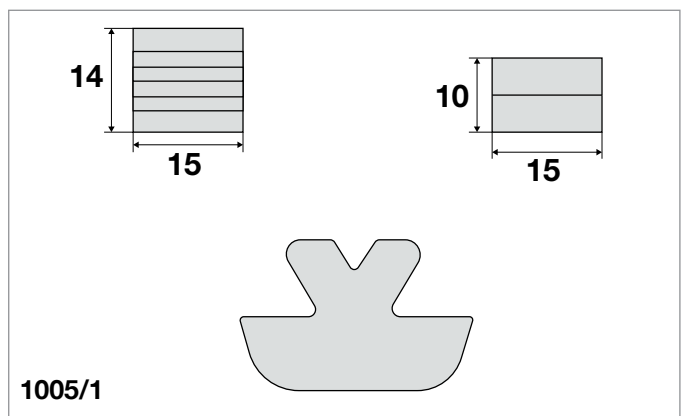
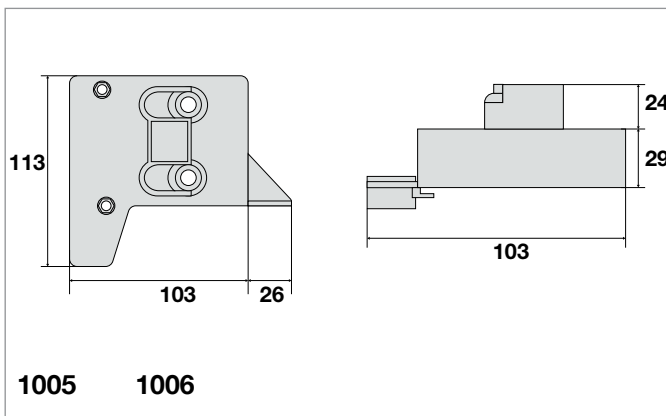
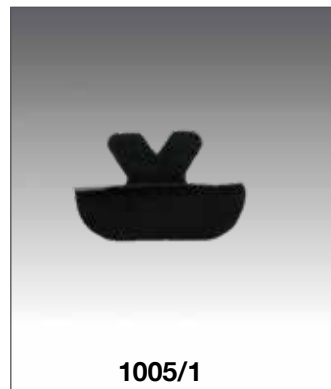
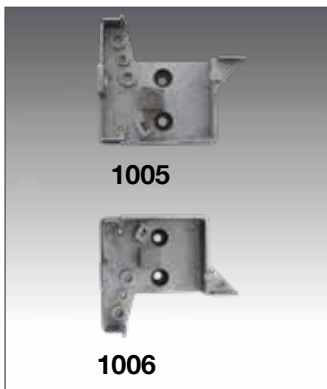

Codice / Code	Descrizione
1005	Controserratura SCHINDLER destra
1006	Controserratura SCHINDLER sinistra
1006/1	Coperchio trasparente contro serratura
1005/1	Gommino per contro serratura SCHINDLER
1007	Leva di abbinamento SCHINDLER porte automatiche destra completa
1008	Leva di abbinamento SCHINDLER porte automatiche sinistra completa
1009	Boccola in bronzo per leva abbinamento SCHINDLER

**TENDIFUNE SOSPENSIONE INTERCAMBIABILE SCHINDLER PER PORTE DI PIANO SEMIAUTOMATICHE - AUTOMATICHE SCHINDLER
 SCHINDLER TENSIONER ROPE INTERCHANGEABLE HANGER FOR SCHINDLER SEMI AUTOMATIC - AUTOMATIC LANDING DOOR**

6

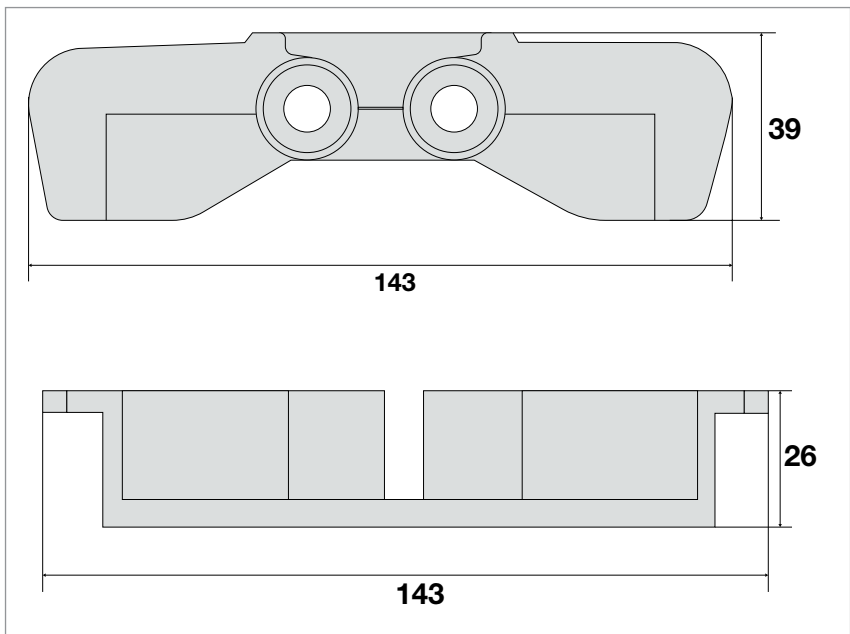
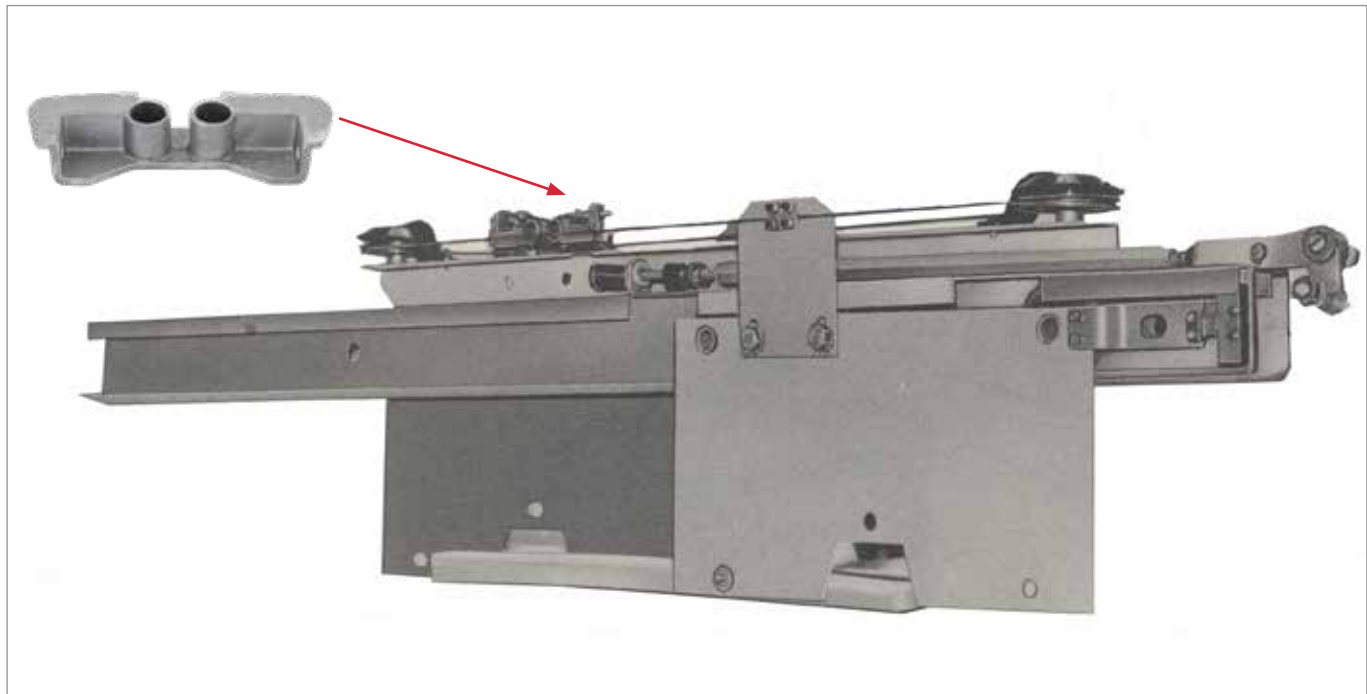

Codice / Code	Descrizione
1000/13	Tendifune presso fuso

BIELLE ASSIEMI CAMMA SCIVOLO ABBINAMENTO PORTE OPERATORI SCHINDLER
SCHINDLER ASSEMBLING ROD AND VANE CAM FOR DOOR COUPLING



1003/11



1003/12

Raffigurati operatori SCHINDLER
 SCHINDLER operator

6

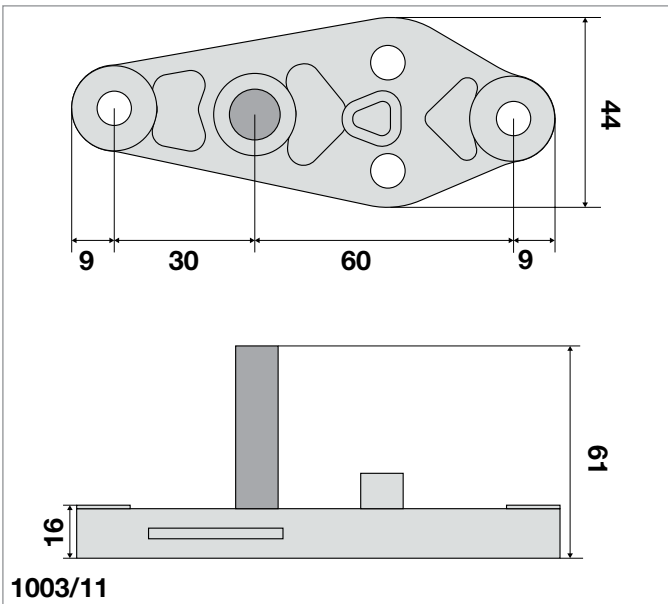

1003/11

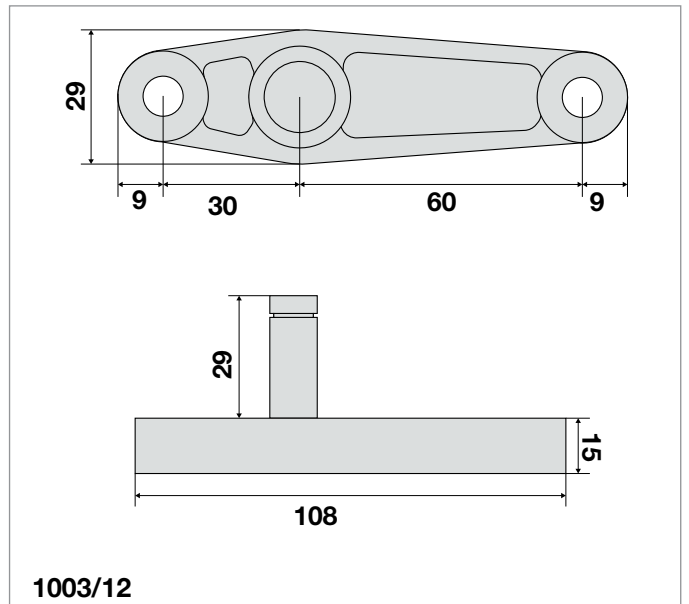

1003/12

Bielletta per assieme camma e scivolo di abbinamento da 700 mm per QKS 9
 Rod for assembling cam and vane for coupling QKS 9 from 700 mm

Codice / Code	Descrizione
1003/11	Bielletta per QKS 9
1003/12	Bielletta per QKS 9

BIELLE ASSIEMI CAMMA SCIVOLO ABBINAMENTO PORTE OPERATORI SCHINDLER
SCHINDLER ASSEMBLING ROD AND VANE CAM FOR DOOR COUPLING

6

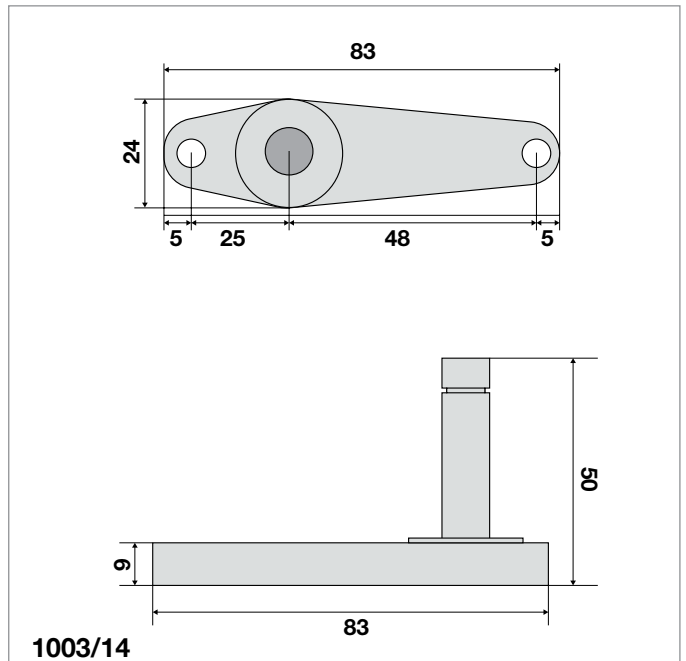
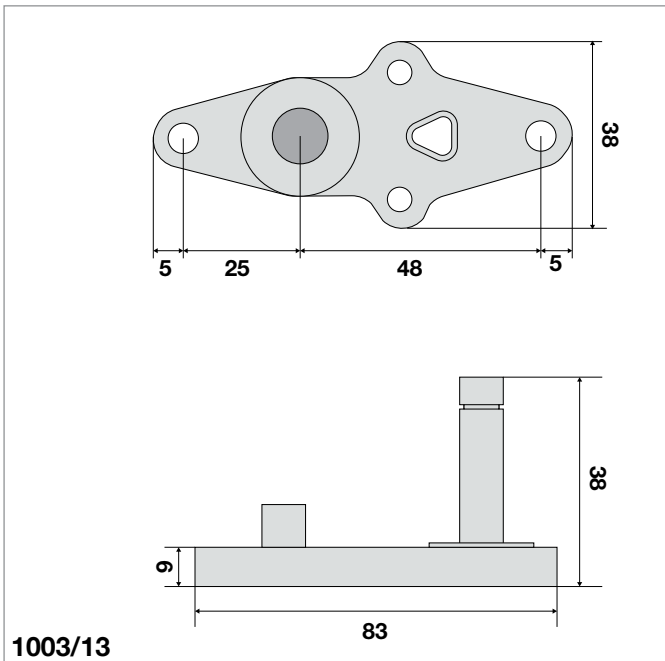

Bielletta per assieme camma e scivolo di abbinamento per QKS 8
 Rod for assembling cam and vane for coupling QKS 8

Codice / Code	Descrizione
1003/13	Bielletta alta per QKS 8
1003/14	Bielletta bassa per QKS 8

BIELETTE E SCIVOLI SCHINDLER ROD AND VANE FOR SCHINDLER

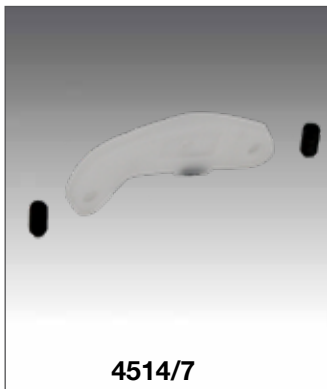

6

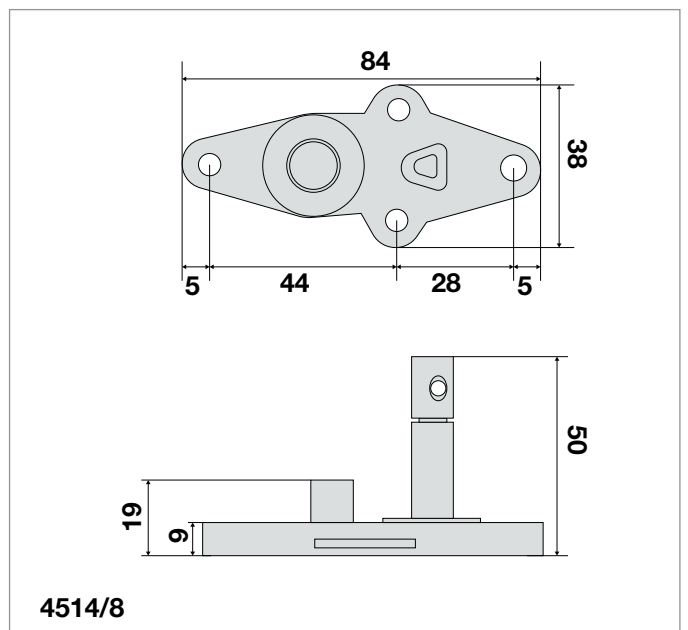
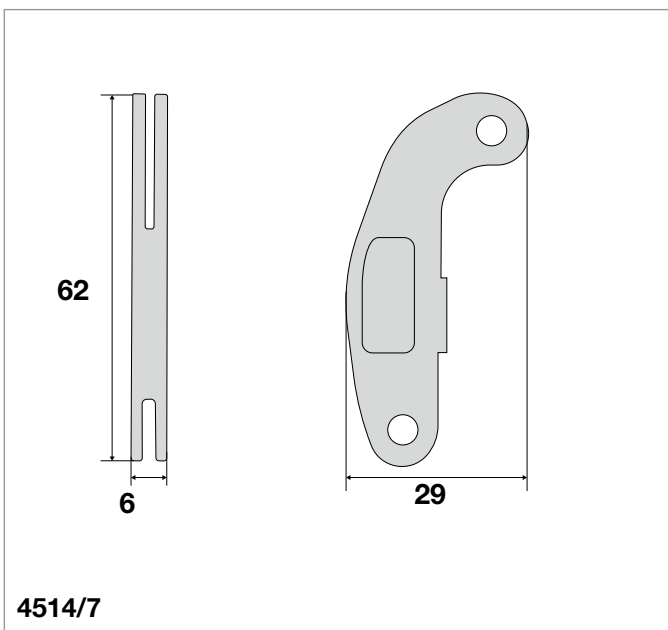

Codice / Code	Descrizione
4514/7	Bielletta braccio operatore SCHINDLER QKS 8
4514/8	Biella navetta alta per camma e scivolo di abbinamento con apertura centrale operatore SCHINDLER QKS 8
4514/9	Scivolo L.460 mm per QKS 8 (destra)
4514/10	Scivolo L.460 mm per QKS 8 (sinistra)
4514/11	Scivolo L.500 mm per QKS 8 (sinistra)

RICAMBI OPERATORI FIAM E FORSID - MONITOR
SPARE PARTS FOR FIAM AND FORSID - MONITOR OPERATORS



6

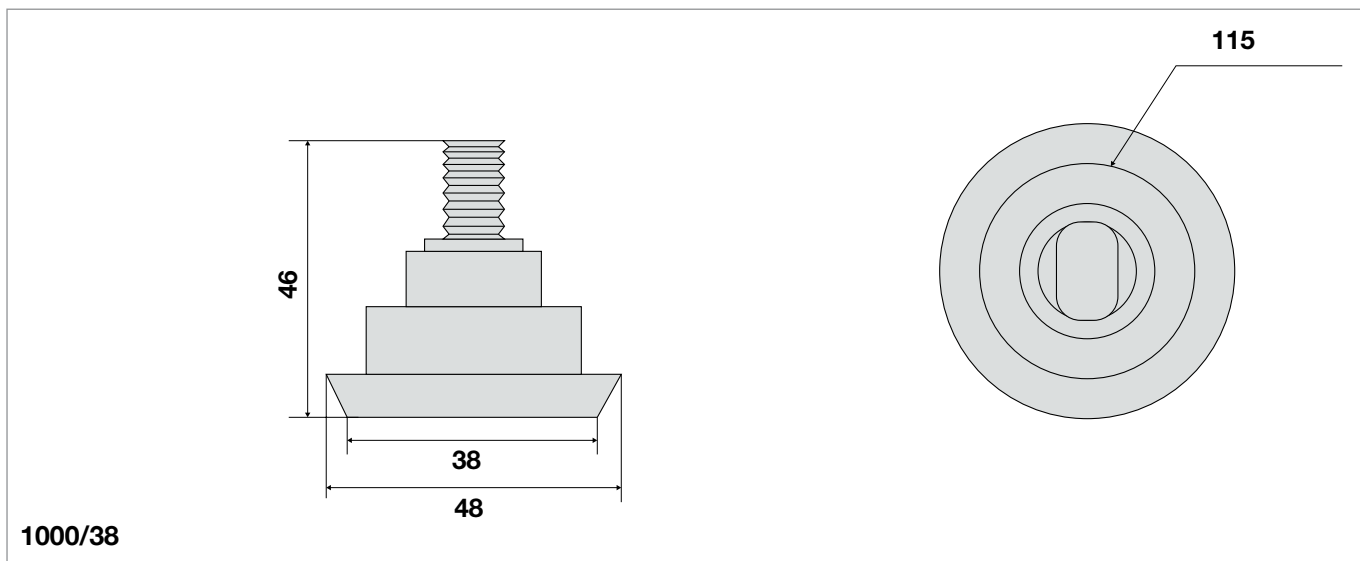
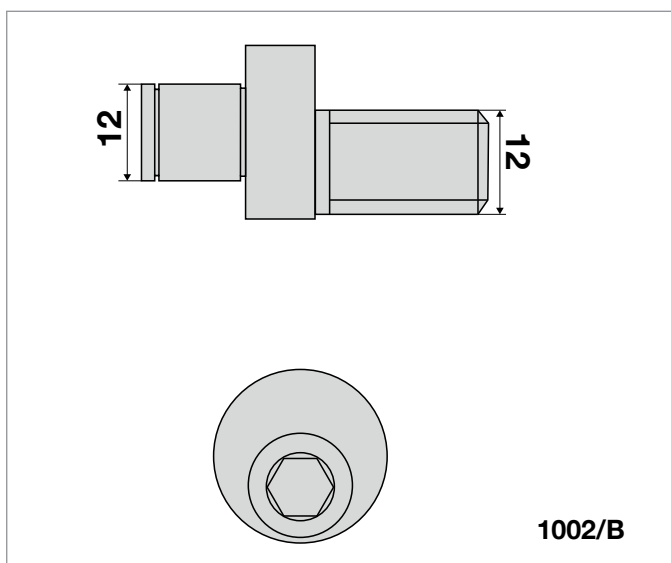
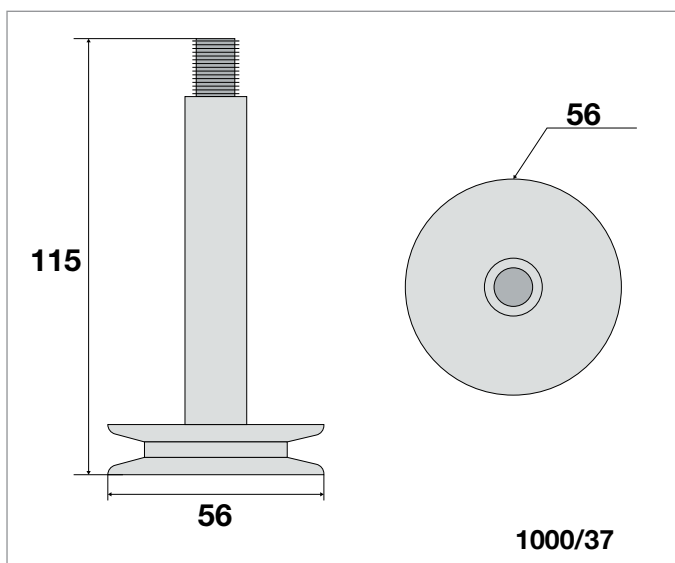

Codice / Code	Descrizione
1000/37	Assieme carrucola comando operatore FIAM tipo S/4PT
1000/38	Eccentrico per porte automatiche FIAM tipo S
1002/B	Perno Eccentrico M12 x 122 per regolazione rotelle di riscontro carrello FORSID - MONITOR

RICAMBI SOSPENSIONI PORTE DI PIANO FIAM
HANGER SPARE PARTS FOR FIAM LANDING DOOR

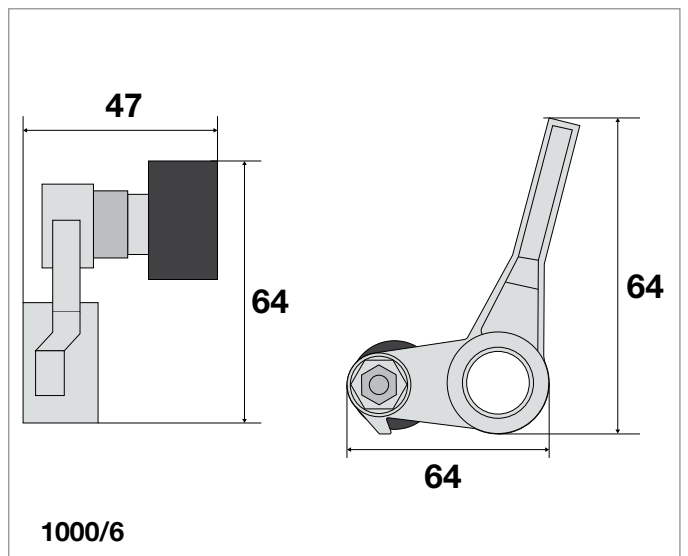
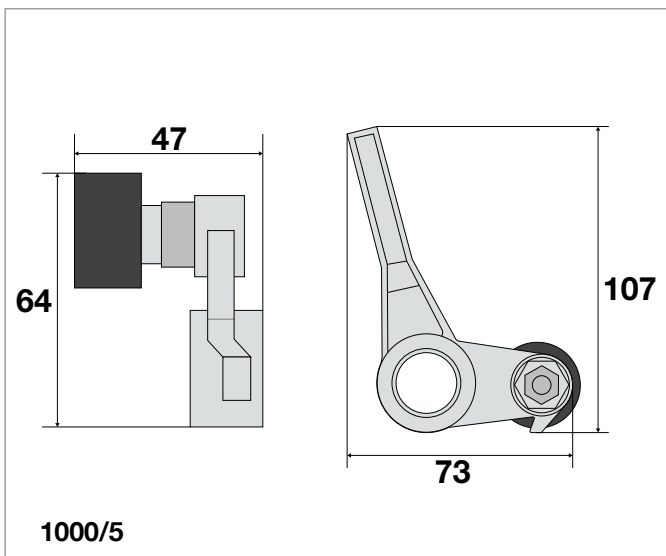
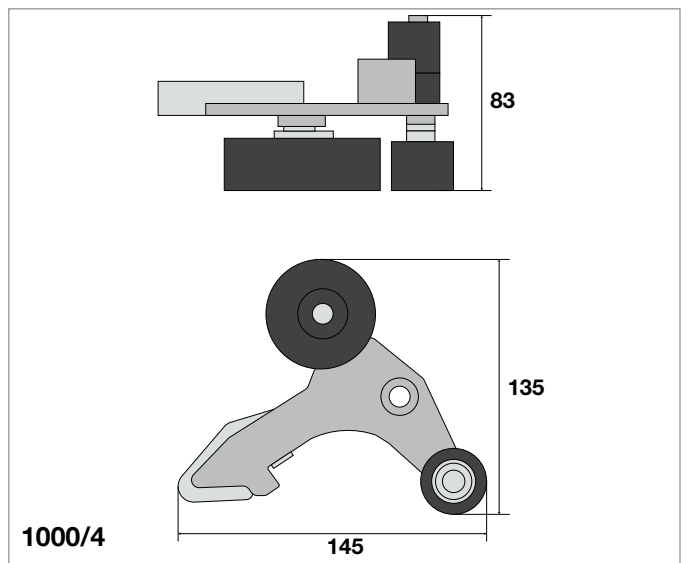
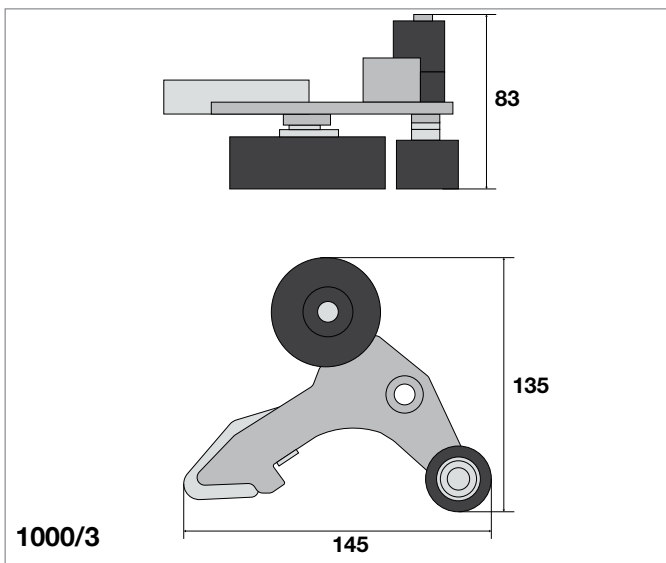

6

Codice / Code	Descrizione
1000/3	Leva di aggancio SX per sospensione A/2PO
1000/4	Leva di aggancio DX per sospensione A/2PO
1000/5	Leva per sospensione B/PT chiusura SX
1000/6	Leva per sospensione B/PT chiusura DX

RICAMBI OPERATORI FIAM A/2PO BIELLA DISPOSITIVO GANCIO OPERATORE
SPARE PARTS FOR FIAM A/2PO ROD UNFASTEN SYSTEM OPERATOR



1000/31



1000/32



1000/33



1000/34

6

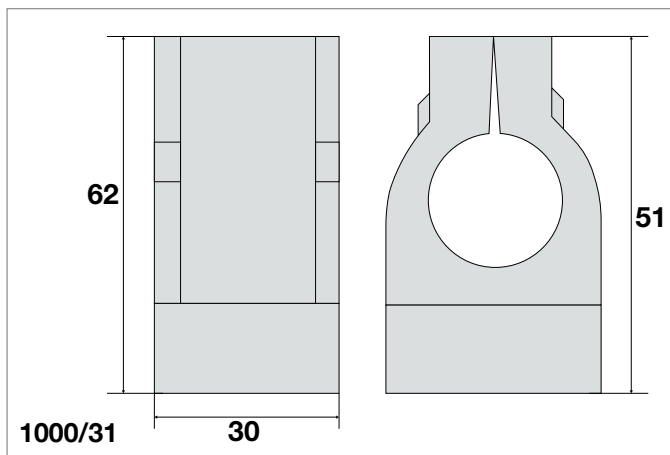
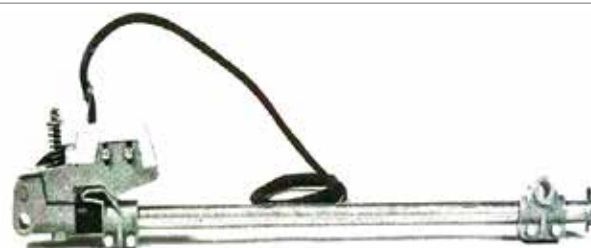

1000/31

30

51

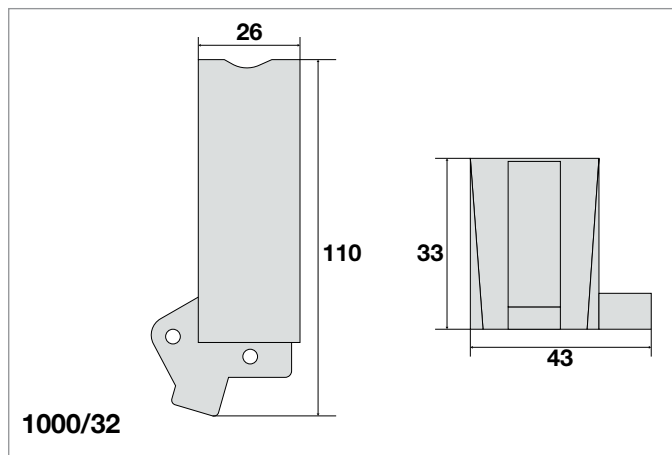

1000/32

26

110

33

43

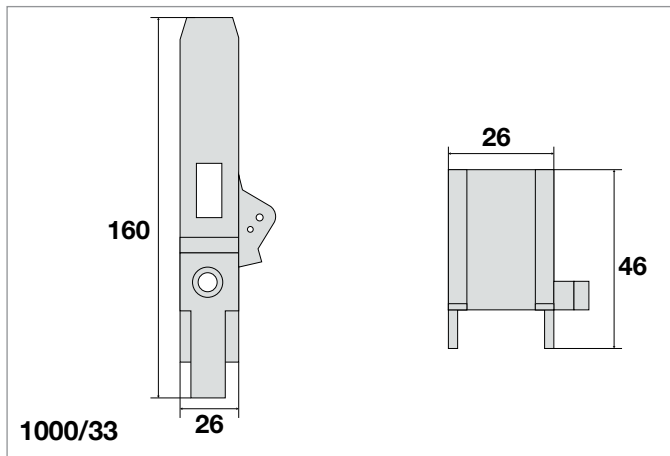

1000/33

26

46

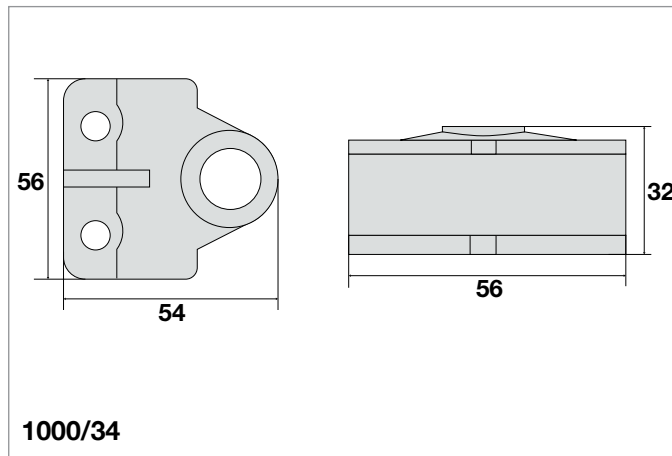

1000/34

56

54

32

56

Codice / Code	Descrizione
1000/31	Nasello aggancio scrocco
1000/32	Copertura contatto per biella
1000/33	Scrocco per operatore
1000/34	Supporto attacco manovella

RICAMBI OPERATORI SOSPENSIONI FIAM A/2PO
HANGER SPARE PARTS FIAM A/2PO

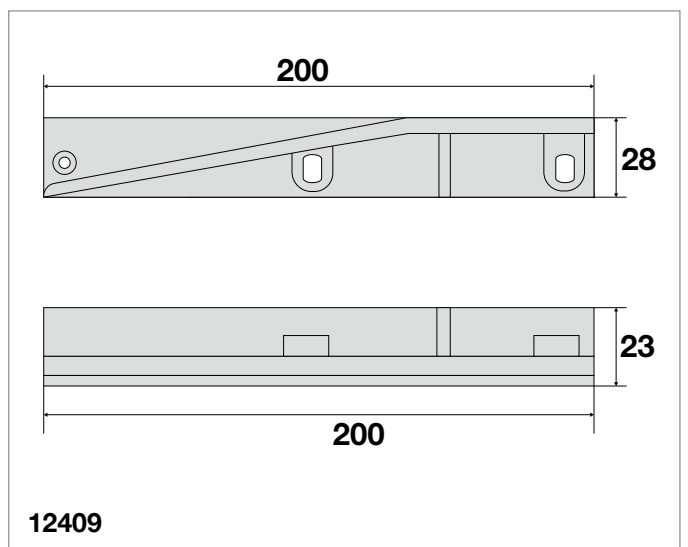
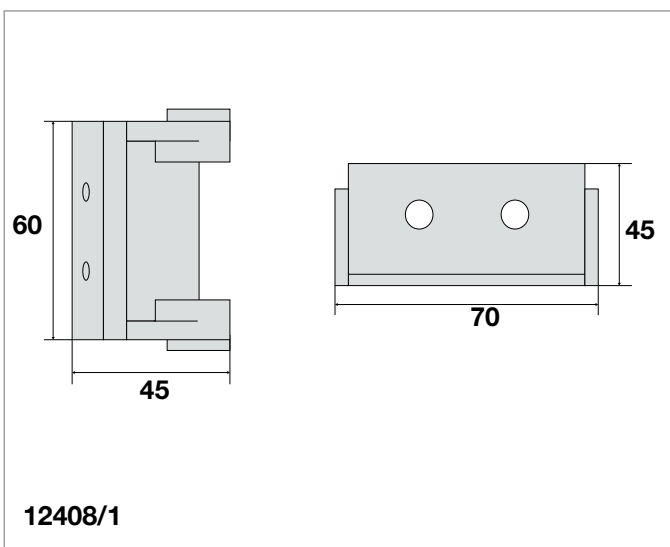
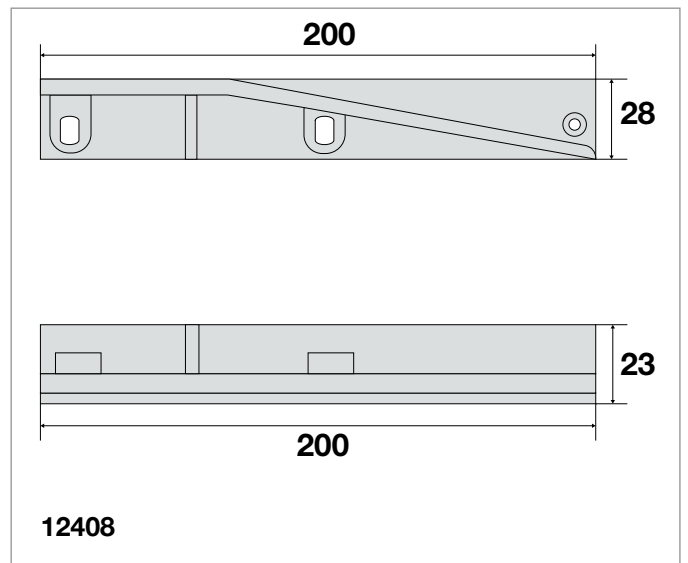
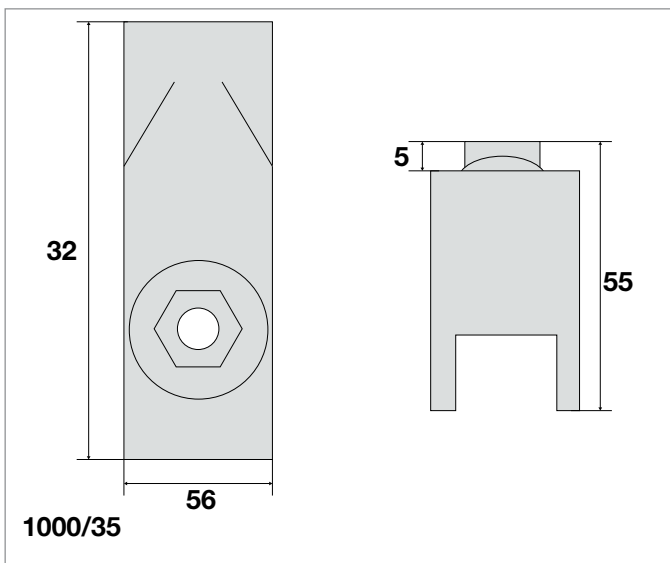

6

Codice / Code	Descrizione
1000/35	Attacco asta automatismo FIAM A/2PO
12408	Scivolo carrello SX sospensione FIAM A/2PO
12408/1	Supporto puntone operatore FIAM A/2PO tipo A
12409	Scivolo carrello DX sospensione FIAM A/2PO

RICAMBI OPERATORI FIAM S/2PT - A/2PO - S/4PT
SPARE PARTS FOR FIAM S/2PT - A/2PO - S/4PT OPERATORS

6

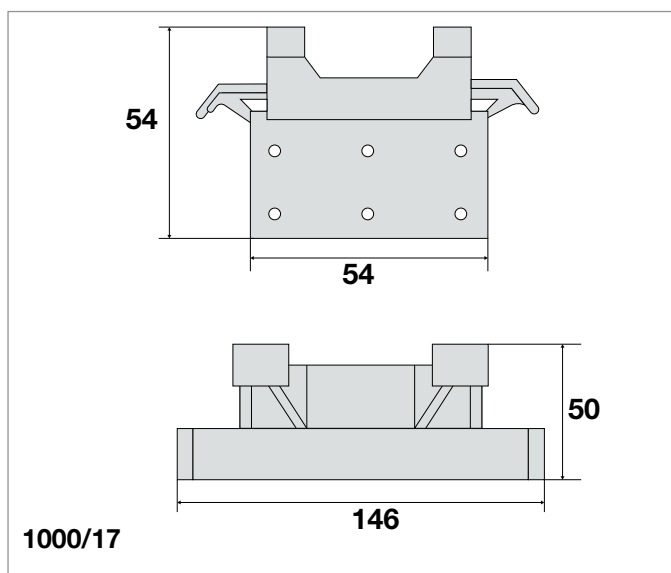
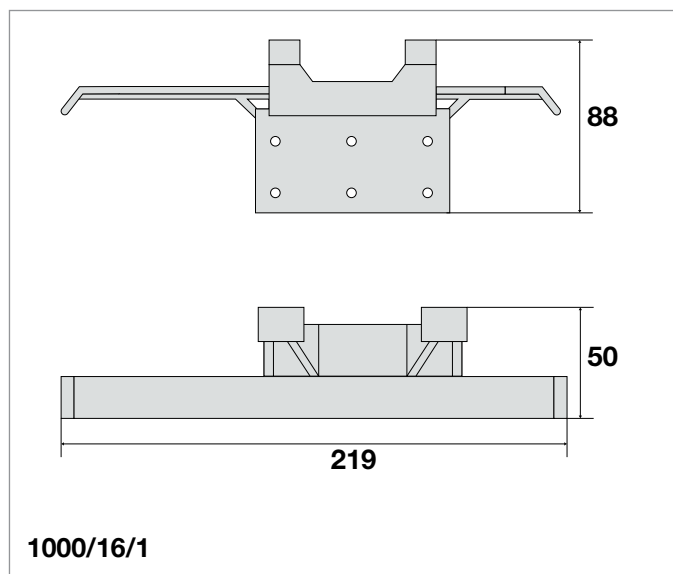
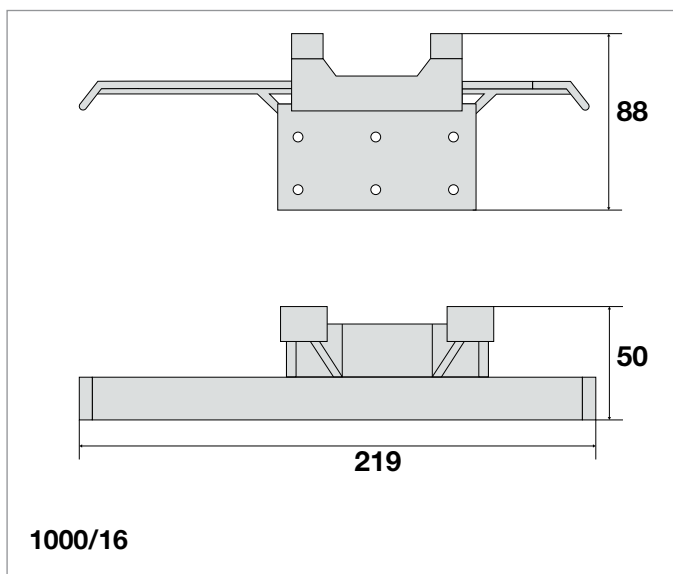

Codice / Code	Descrizione
1000/16	Scivolo DX per azionamento contatto tendicatena FIAM S/2PT
1000/16/1	Scivolo SX per azionamento contatto tendicatena FIAM S/2PT
1000/17	Scivolo per azionamento contatto chiusura e tendicatena FIAM S/2PT S/4PT

RICAMBI OPERATORI FIAM S/2PT - A/2PO - S/4PT
SPARE PARTS FOR FIAM S/2PT - A/2PO - S/4PT OPERATORS

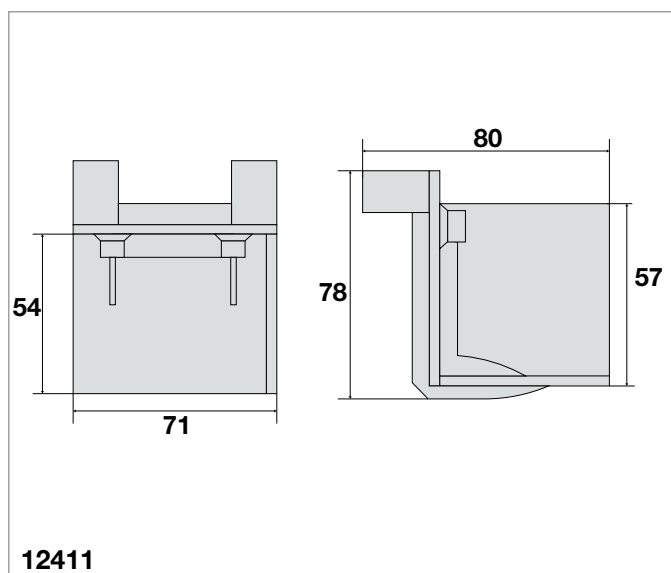
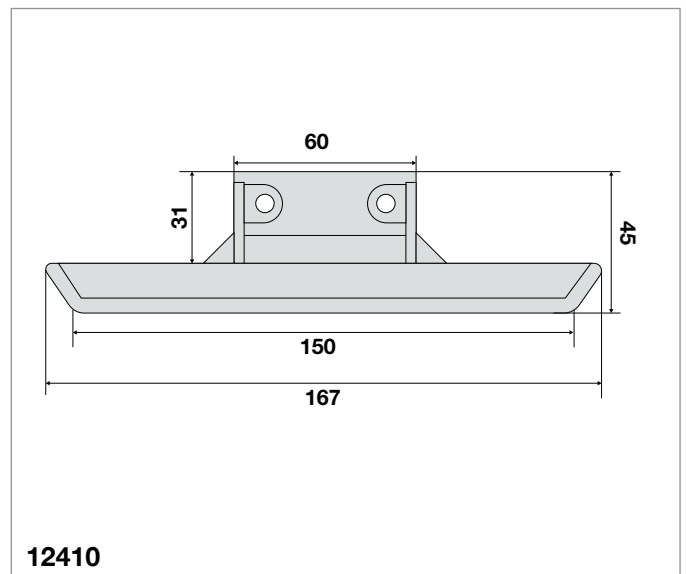
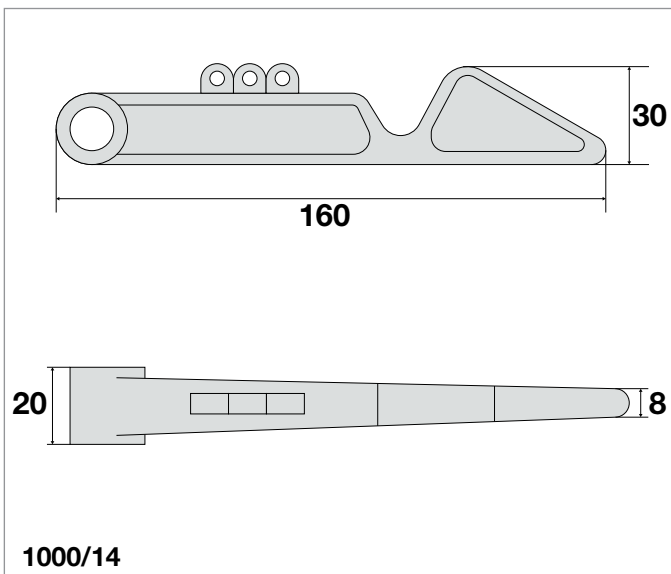

6

Codice / Code	Descrizione
1000/14	Leva di aggancio per operatore FIAM S
12410	Scivolo per contatti automatismo FIAM A/2PO
12411	Supporto contatti motoriduttore A/2PO

RICAMBI OPERATORI SOSPENSIONI FIAM FIAM HANGER SPARE PARTS

6

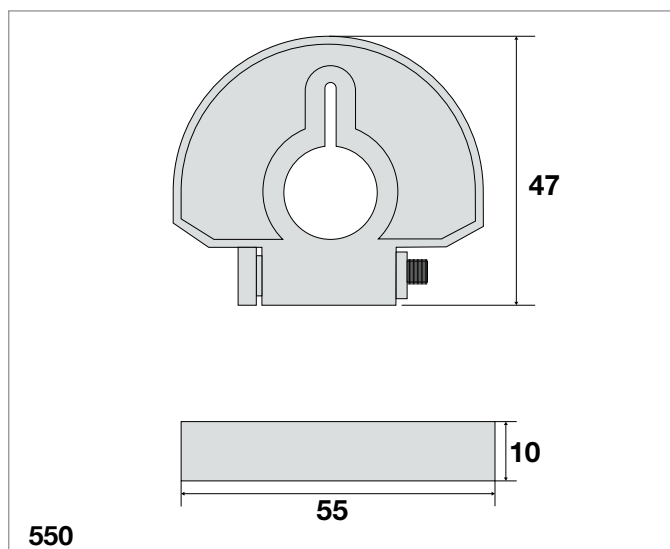
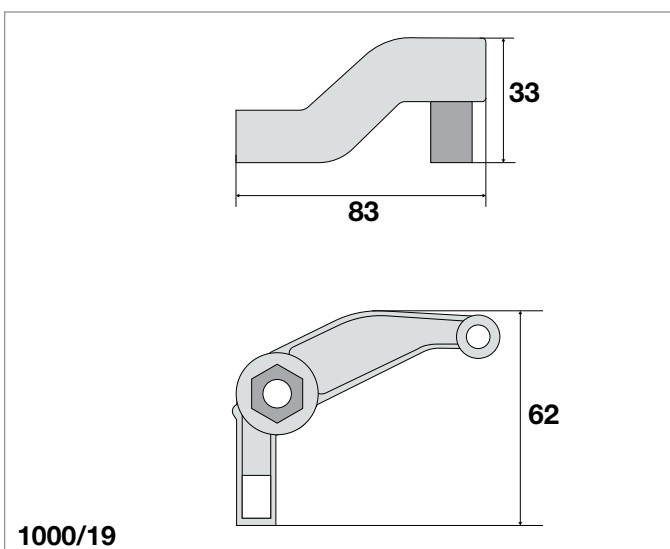
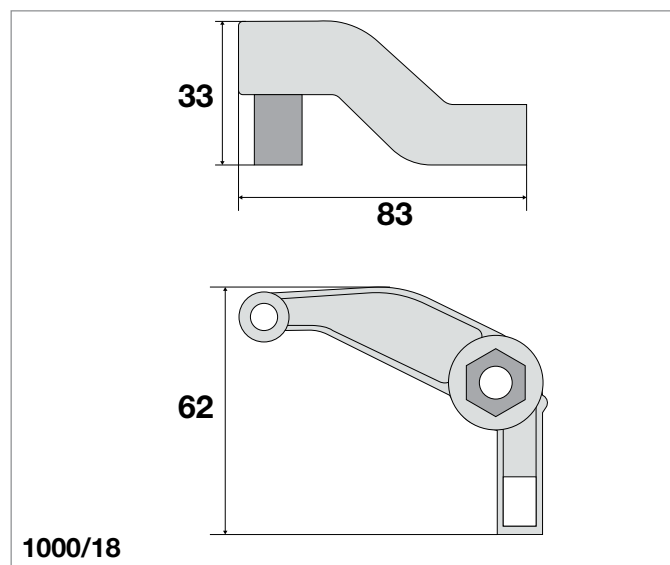
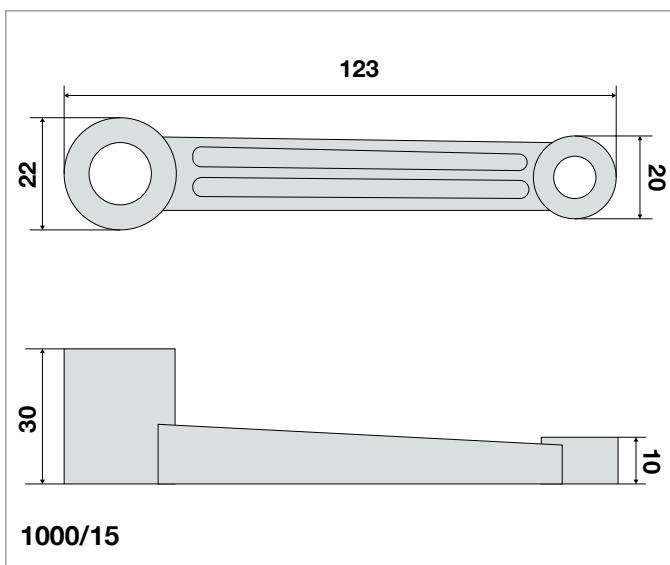

Codice / Code	Descrizione
1000/15	Leva galoppino tendicinghia per operatore FIAM tipo S
1000/18	Leva comando catenaccio SX per sospensioni FIAM tipo S
1000/19	Leva comando catenaccio DX per sospensioni FIAM tipo S
550	Gamma contatti motoriduttore FIAM tipo MR041

RICAMBI OPERATORI E SOSPENSIONI FIAM
FIAM SPARE PARTS AND HANGER

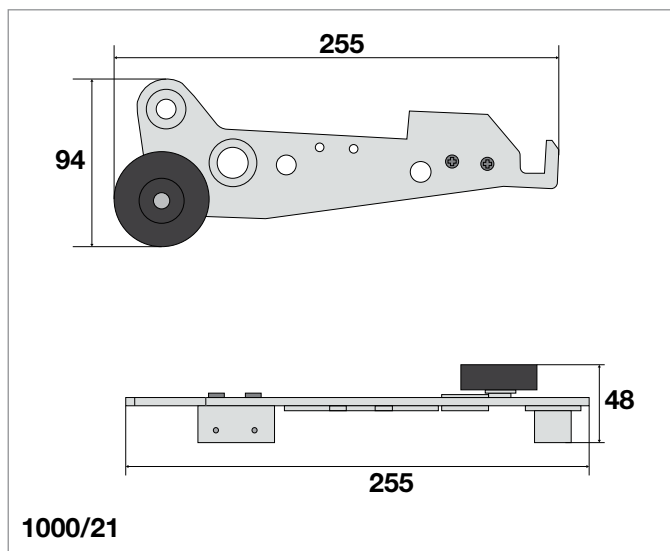
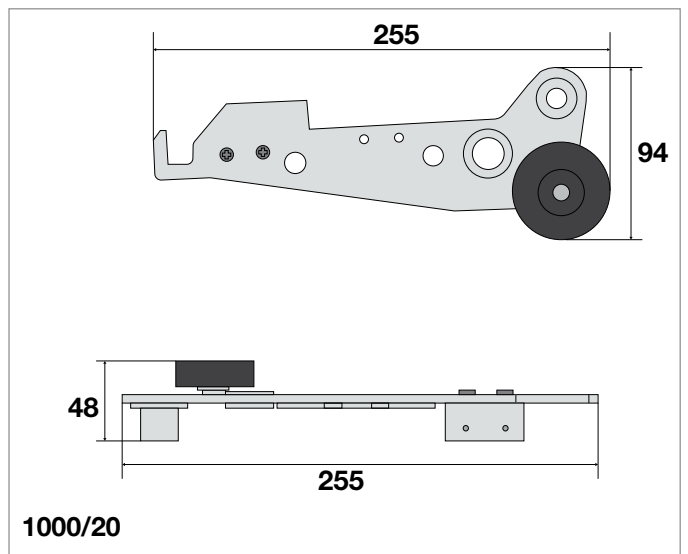
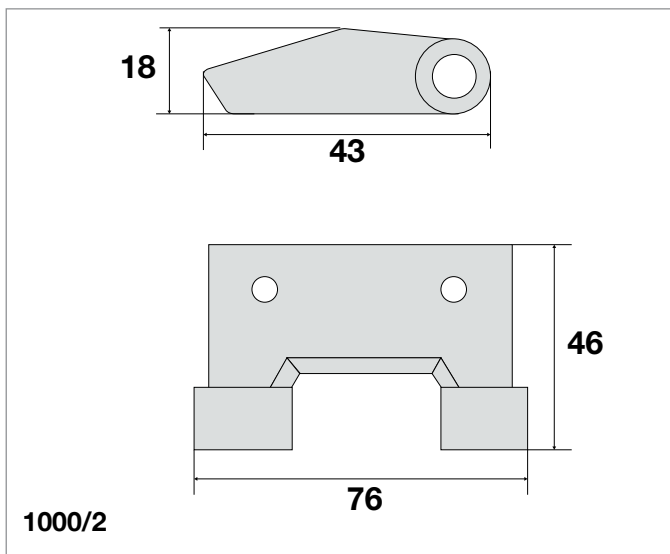
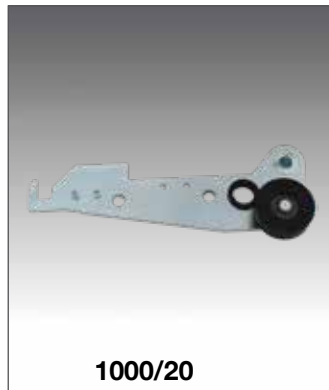
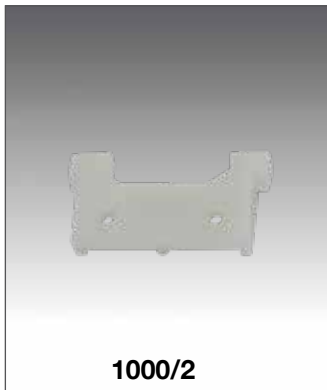

6

Codice / Code	Descrizione
1000/2	Tendicatena e tendifune per automatismo FIAM S/2PO - B/2PT
1000/20	Leva aggancio sospensione FIAM B/2PT sinistra
1000/21	Leva aggancio sospensione FIAM B/2PT destra

RICAMBI OPERATORI E SOSPENSIONI SABIEM
SABIEM SPARE PARTS AND HANGER



6

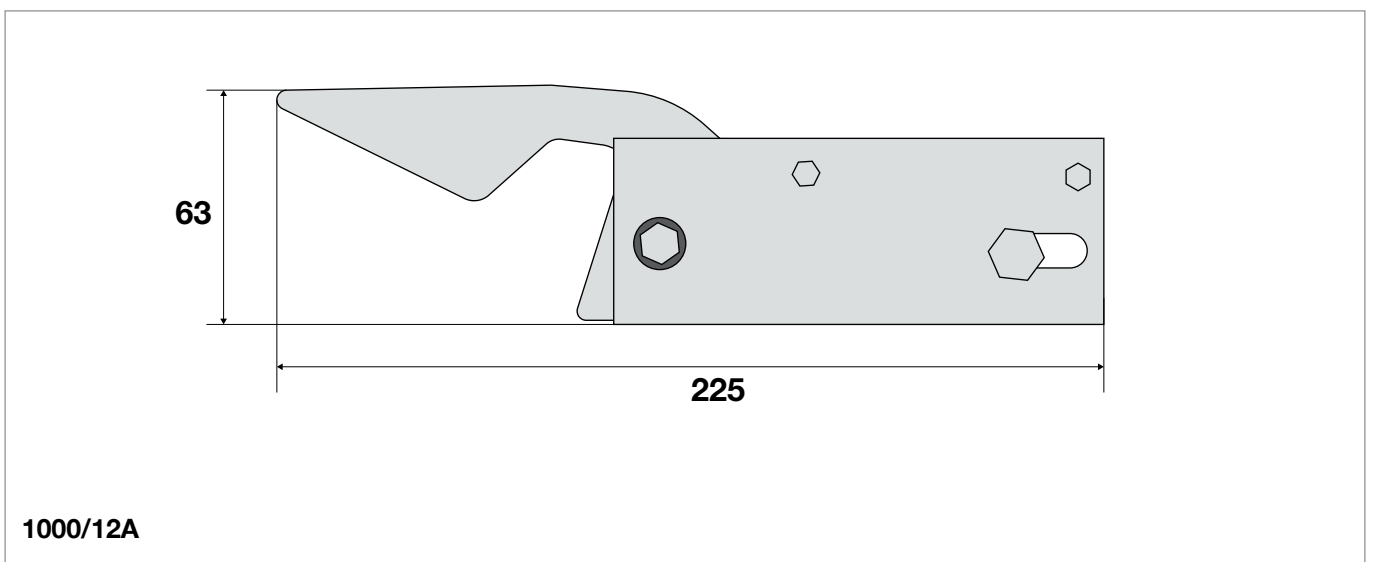
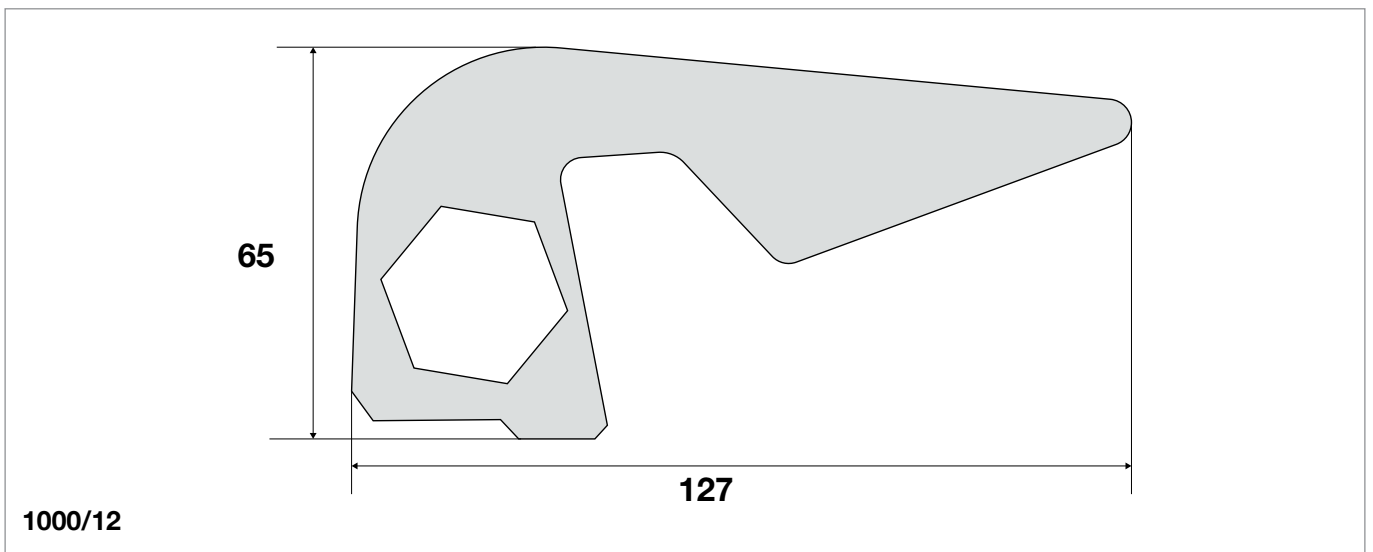

Codice / Code	Descrizione
1000/12	Gancio blocco operatore e sospensione SABIEM
1000/12A	Leva gancio di blocco operatore SABIEM con supporto

RICAMBI OPERATORI E SOSPENSIONI SABIEM
SABIEM SPARE PARTS AND HANGER SABIEM

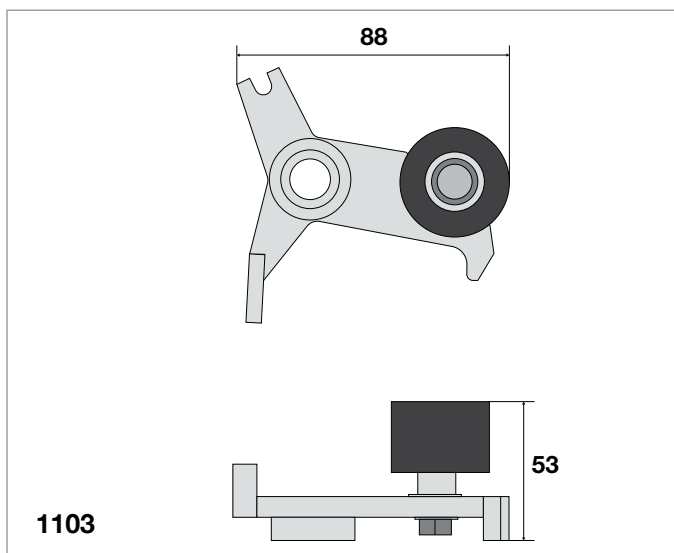
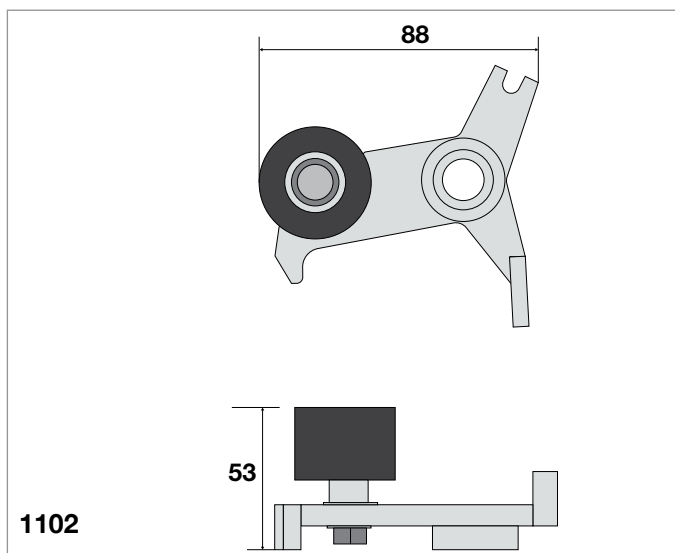
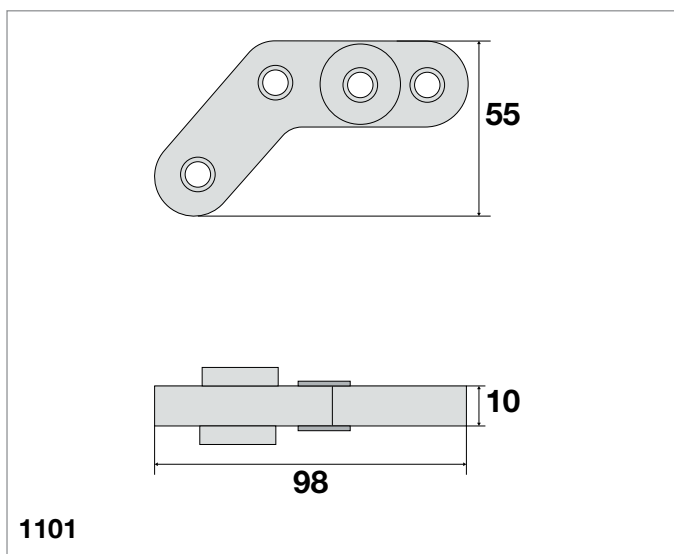
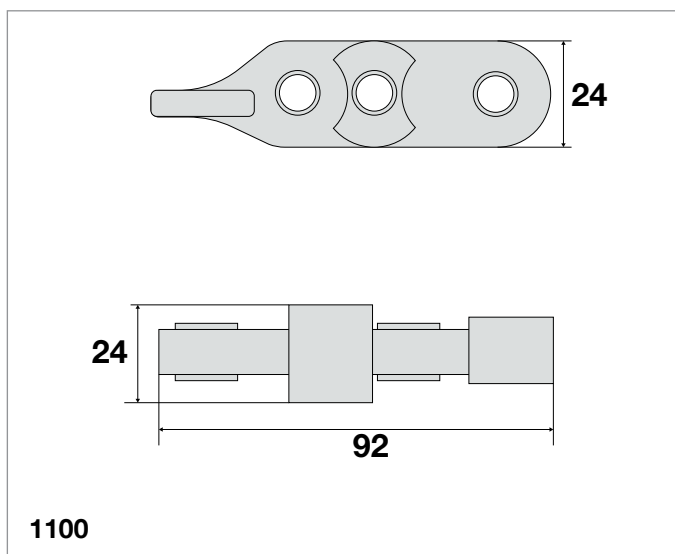

6

Codice / Code	Descrizione
1100	Leva inferiore innesto operatore SABIEM
1101	Leva superiore per operatore SABIEM
1102	Controleva catenaccio sospensione di piano SABIEM DX
1103	Controleva catenaccio sospensione di piano SABIEM SX

OPERATORE OTIS 9550 T OTIS OPERATOR 9550 T



6

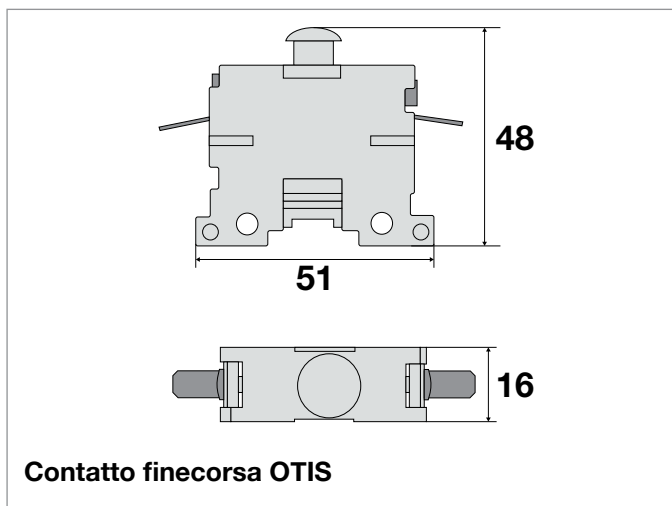
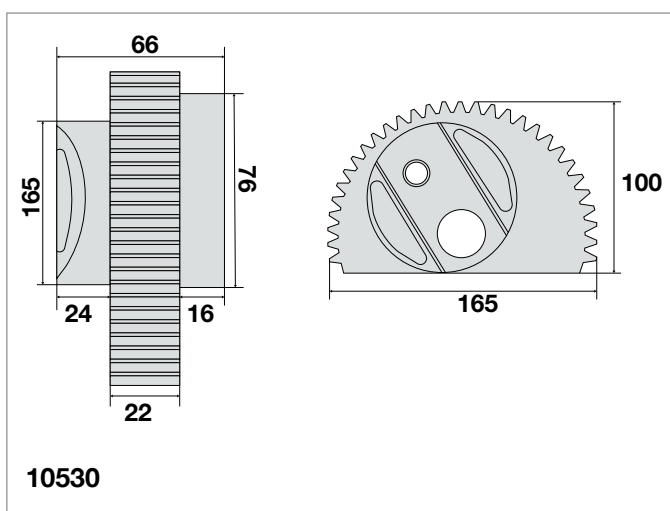
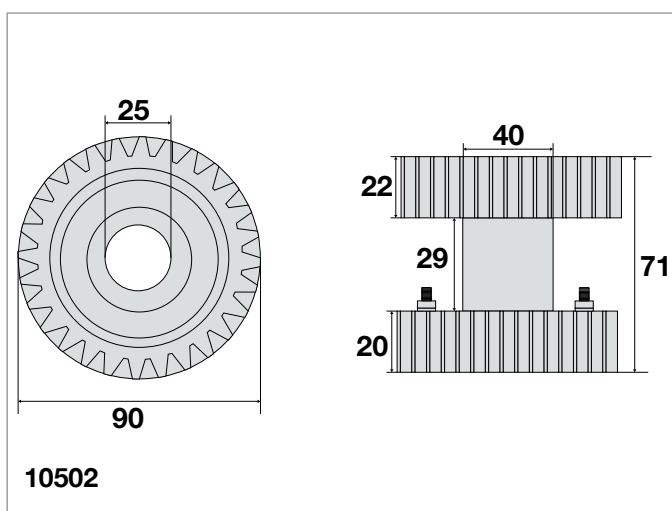

Blocco operatore OTIS 9550T
Il solo motore non viene venduto separatamente
The engine alone is not sold separately

Specificare i giri del motore
Specify the speed of motor



Codice / Code	Descrizione
10502	Ingranaggio doppio
10530	Mezzo ingranaggio
10531	Carter
145460T	Contatto Extracorsa N.C
145470T	Contatto finecorsa N.C
145480T	Contatto finecorsa N.A

Volt	Giri	Codice
380 x 3	750	10531A
380 x 3	1000	10531B
105 x 3	750	10531C
105 x 3	1000	10531D

RICAMBI OTIS PER OTIS SPARE PARTS FOR OPERATORS



1000/40 ORLY 9940



OTIS 9550 T, 9550C
10531/3



10531/7



OTIS 6850
2030

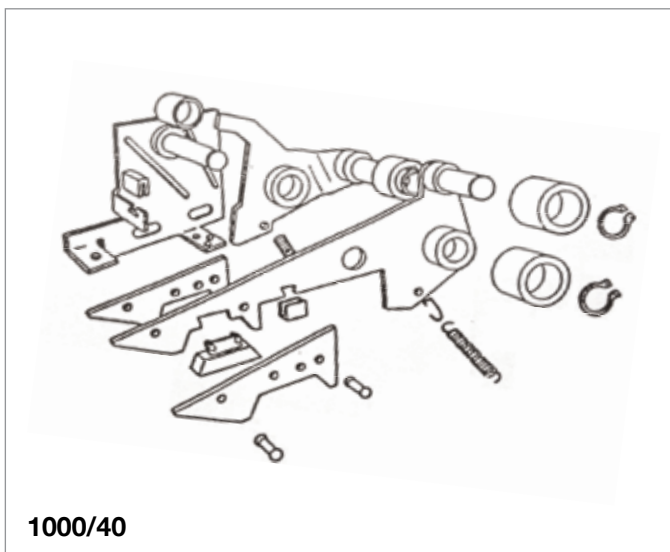

1000/40

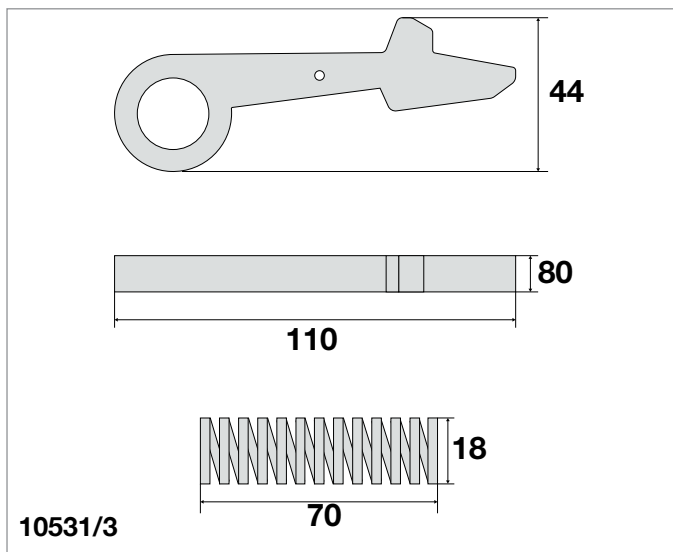

10531/3

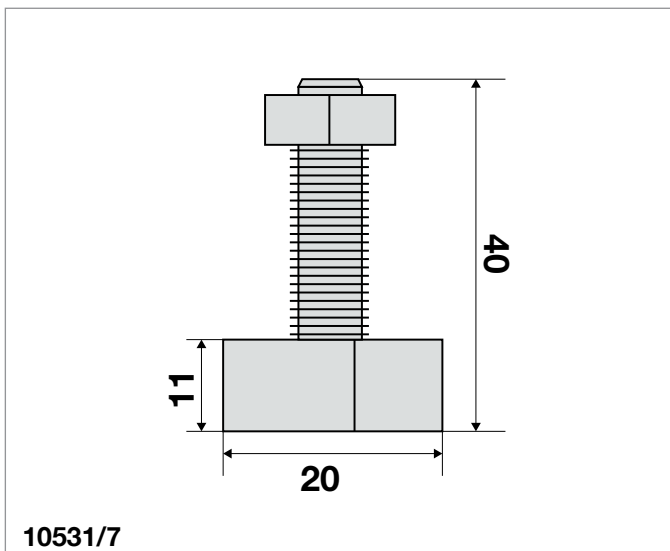

10531/7

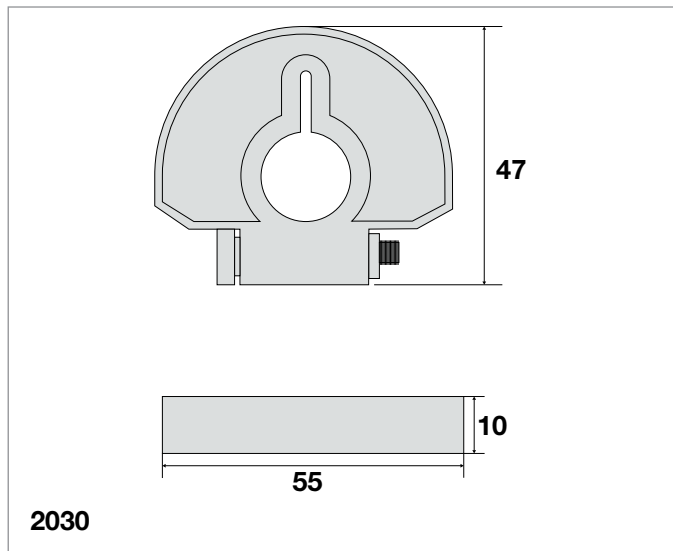

2030

6

Codice / Code	Descrizione
1000/40	Leve gancio e ricambi operatori OTIS DX ORLY 9940
1000/41	Leve gancio e ricambi operatori OTIS SX ORLY 9940
10531/3	Levetta per operatori OTIS 9550T - 9550 C
10531/7	Ricambi operatore porte OTIS 9550CC gommino paracolpi
2030	Camma operatore OTIS 6850

RICAMBI OPERATORI FALCONI ADATTABILI OTIS
FALCONI SPARE PARTS SUITABLE FOR OTIS OPERATORS



6

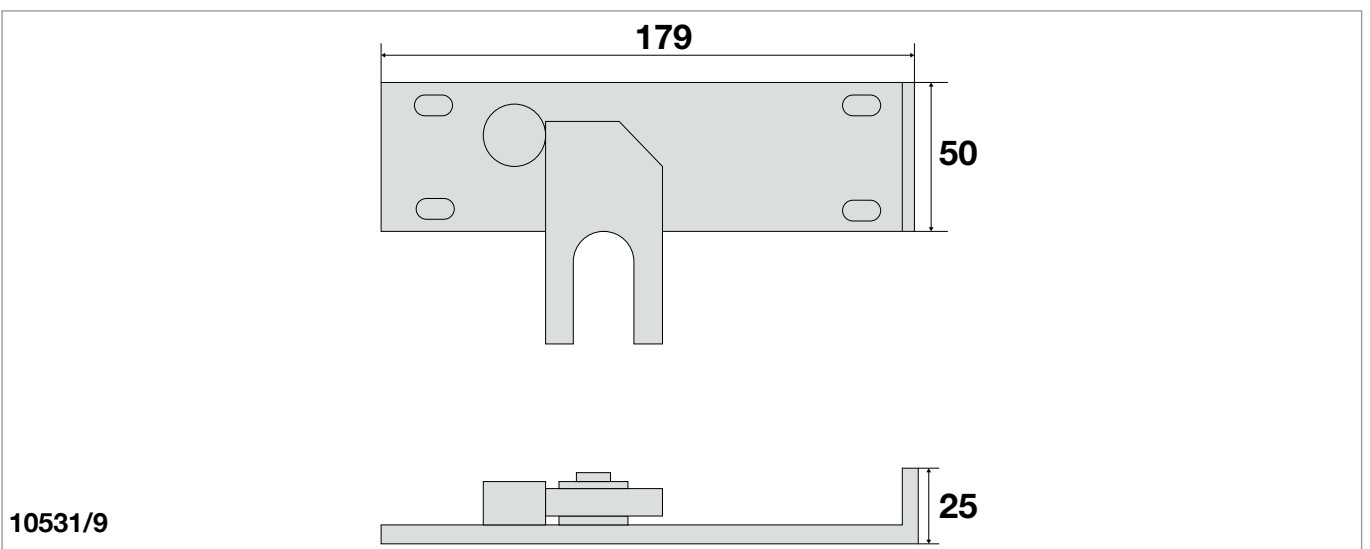
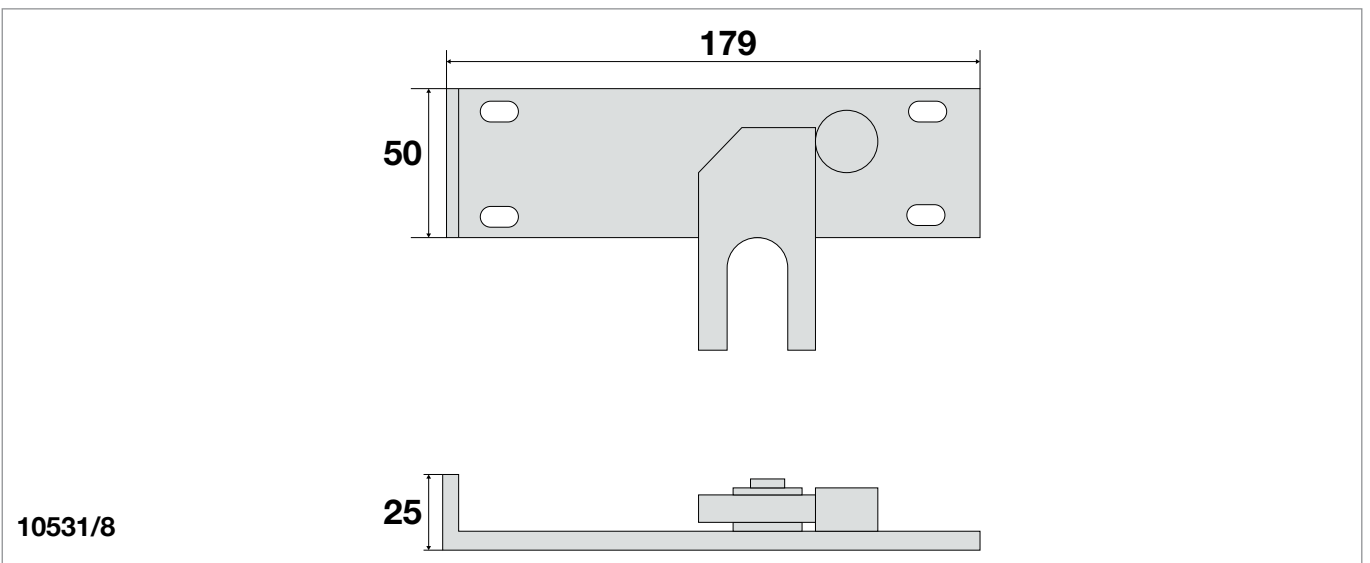

Codice / Code	Descrizione
10531/8	Fermaporta per operatore FALCONI - OTIS DX
10531/9	Fermaporta per operatore FALCONI - OTIS SX

RICAMBI PER SOSPENSIONI IGV
SPARE PARTS FOR HANGER IGV

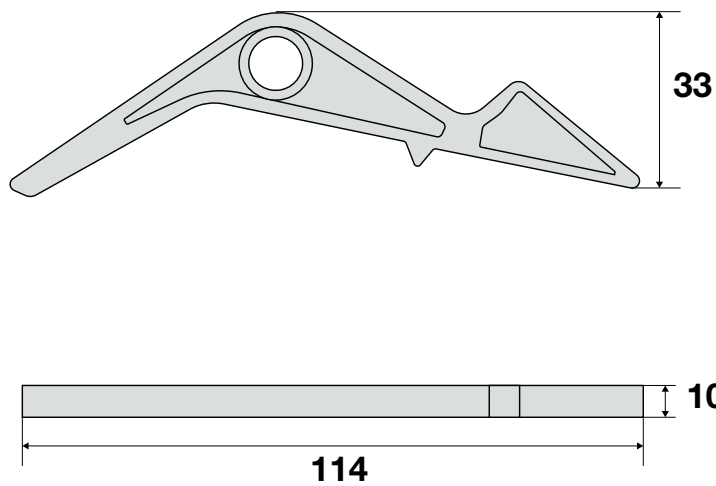

1000

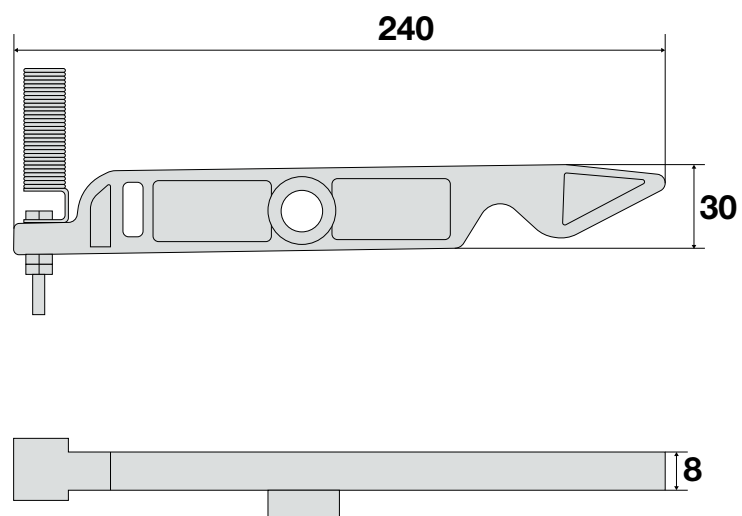

1002

6

Codice / Code	Descrizione
1000	Ganci per sospensioni IGV
1002	Ganci per sospensioni IGV con molla

PULEGGE PULEY



8057



8058

6

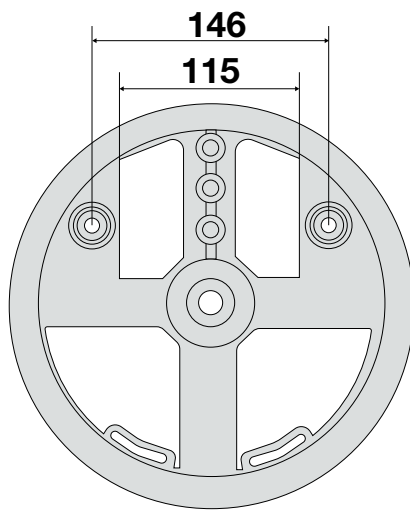

8057

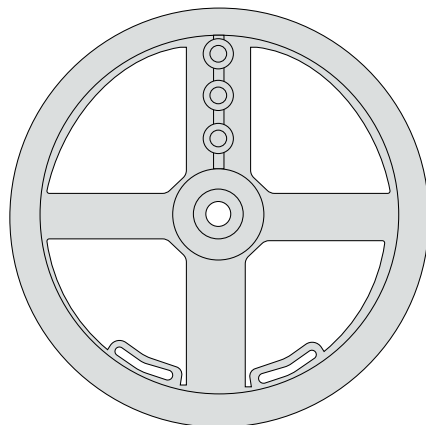
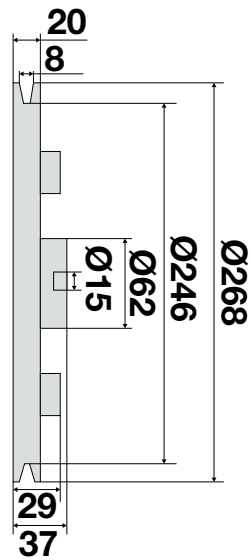

8058

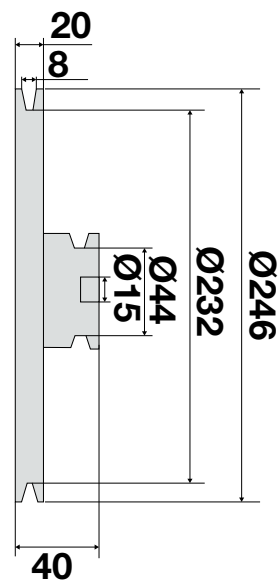

Codice / Code	Descrizione
8057	Puleggia per operatore CF 12 BASSETTI
8058	Puleggia per operatore B268 BASSETTI

COMMUTATORI - FINECORSA - IMPULSORI MAGNETICI - LAME TAGLIAFLUSSO - DISPOSITIVO AUTOLIVELLAMENTO - IMPIANTI IDRAULICI PER ASCENSORE STANDARD E BASSETTI, OTIS, FIAM, SAFOV, SICEM , FORSID-MONITOR, DMG

FLOOR REVERSE AND LIMIT SWITCH - MAGNETIC SWITCH - STRAIGHT ADJUSTABLE INDUCTION PLATE - AUTOMATIC SELF LEVELLING DEVICE - HYDRAULIC LIFT SYSTEM FOR STANDARD, BASSETTI, OTIS, FIAM, SAFOV, SICEM, FORSID-MONITOR, DMG

Commutatori e finecorsa DMG rotella Ø 42-48	7.4
<i>Floor reverse and limit switch DMG roller Ø 42-48</i>	
Commutatori e finecorsa intercambiabili OTIS	7.5
<i>Floor reverse and limit switch interchangeable OTIS</i>	
Commutatori e finecorsa BASSETTI	7.6
<i>Floor reverse and limit switch BASSETTI</i>	
Commutatori e finecorsa FIAM	7.7
<i>Floor reverse and limit switch FIAM</i>	
Commutatori e finecorsa intercambiabili SAFOV	7.9
<i>Floor reverse and limit switch interchangeable SAFOV</i>	
Commutatori e finecorsa "SILVER SWITCH FORSID - MONITOR"	7.11
<i>Floor reverse and limit switch "SILVER SWITCH FORSID - MONITOR"</i>	
Commutatori intercambiabile BASSETTI / FORSID - MONITOR	7.9
<i>Floor reverse interchangeable BASSETTI / FORSID - MONITOR</i>	
Coppia camme e sagoma commutazione FIAM	7.12
<i>A pair of reversing cam metal sheet FIAM</i>	
Dispositivo di autolivellamento per impianti oledinamici	7.19
<i>Automatic self-levelling device</i>	
Impulsore magnetico anello Verde / Rosso / Rosso + Verde Bistabile	7.17
<i>Cylindrical magnetic sensor Green / Red / Red + Green bistable</i>	
Impulsore magnetico FORSID	7.13
<i>Magnetic switch FORSID</i>	

Impulsore magnetico FALCONI	7.13
<i>Magnetic switch FALCONI</i>	
Impulsore magnetico rosso/verde	7.13
<i>Magnetic switch red/green</i>	
Impulsore magnetico SICEM	7.14
<i>Magnetic switch SICEM</i>	
Impulsore magnetico FIAM	7.14
<i>Magnetic switch FIAM</i>	
Impulsore magnetico bistabile intercambiabile SCHINDLER	7.14
<i>Magnetic switch bistable sensor interchangeable SCHINDLER</i>	
Impulsore magnetico cilindro Ø 12 x L. 104	7.15
<i>Magnetic switch cylinder Ø 12 x L. 104</i>	
Impulsore magnetico in ottone filettato Ø 10 x L. 85mm	7.16
<i>Cylindrical magnetic sensor in brass threaded Ø 10 x L. 85mm</i>	
Impulsore magnetico bistabile Ø 12 x L. 104	7.15
<i>Bistable Inductor Switch Ø 12 x L. 104</i>	
Lame tagliaflusso per impulsore magnetico	7.18
<i>Straight adjustable induction plate for magnetic switch</i>	
Magnete tondo e rettangolare	7.15
<i>Cylinder and rectangular magnet</i>	
Ricambi commutatori fincorsa "SAFOV ORIGINALI e FORSID - MONITOR"	7.10
<i>Floor reverse limit switch " SAFOV ORIGINAL and FORSID - MONITOR "</i>	
Ricambi commutatore FIAM	7.8
<i>Floor reverse spare parts FIAM</i>	

Sagome in plastica BASSETTI 7.12
Reversing in plastic BASSETTI

Scivoli per contatto a 1 o 2 piste 7.19
Landing releveilling in 1 or 2 tracks

Note: I componenti sul catalogo con riportata una specifica marca di ascensore sono utilizzati abitualmente solo da questa marca. I particolari senza marca sono utilizzati da più marche di ascensori.

Note: *The components in the catalogue with a specific lift brand are usually used only by the brand. Unbranded parts are used by multiple lift brands.*

COMMUTATORI E FINECORSA DMG FLOOR REVERSE AND LIMIT SWITCH DMG

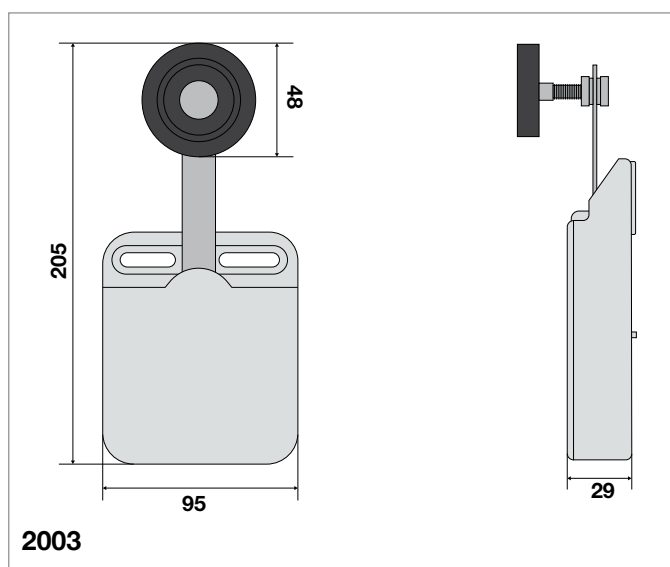
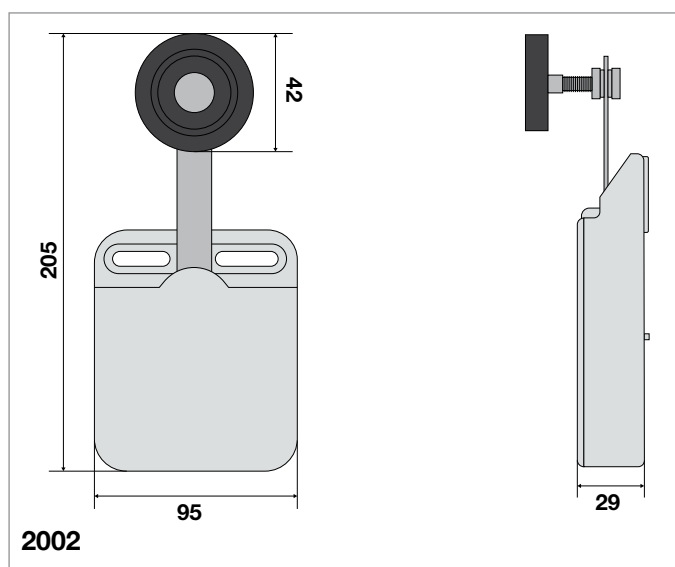
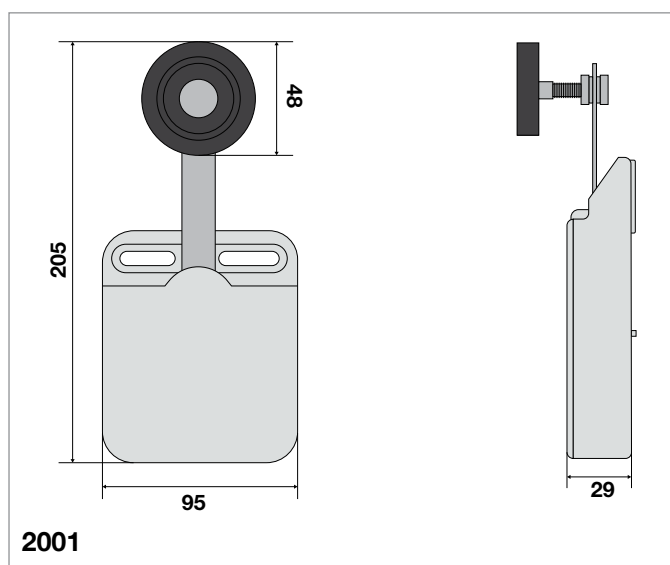
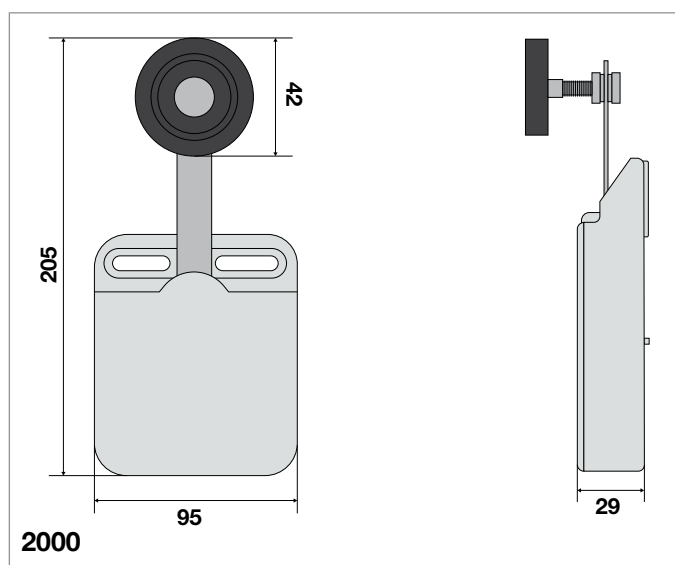

Codice / Code	Descrizione
2000	Commutatore DMG con ruota Ø 42 mm
2001	Commutatore DMG con ruota Ø 48 mm
2002	Finecorsa ambidestro DMG con ruota Ø 42 mm
2003	Finecorsa ambidestro DMG con ruota Ø 48 mm

COMMUTATORI E FINECORSA OTIS OTIS FLOOR REVERSE AND LIMIT SWITCH

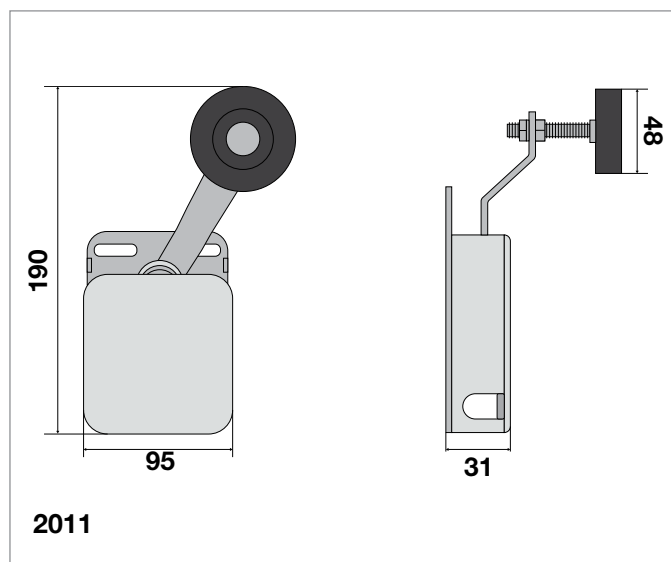
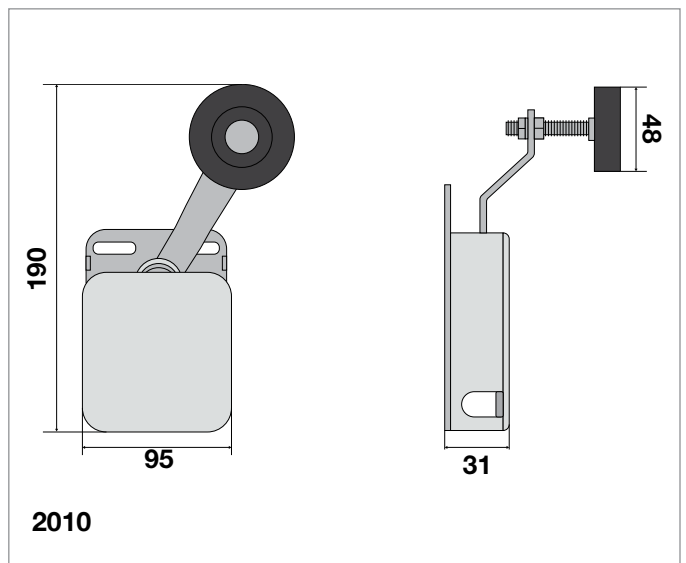
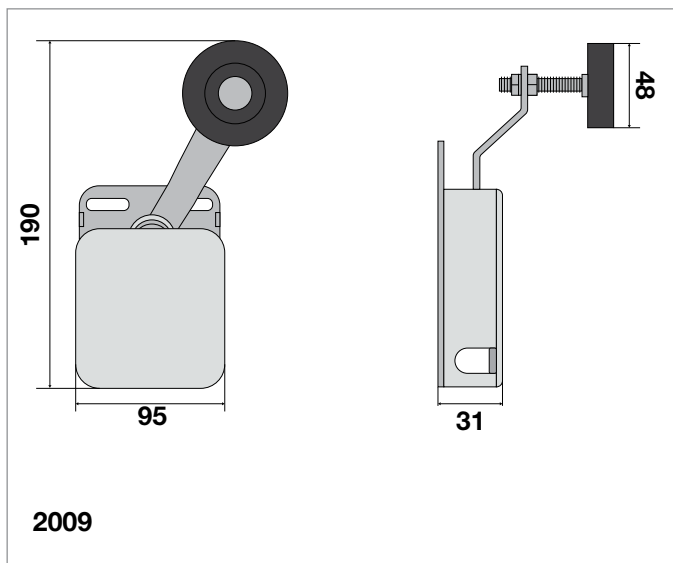

Codice / Code	Descrizione
2009	Commutatore di piano OTIS con ruota Ø 48 mm
2010	Commutatore di finecorsa OTIS SX con ruota Ø 48 mm
2011	Commutatore di finecorsa OTIS DX con ruota Ø 48 mm

COMMUTATORI E FINECORSA BASSETTI BASSETTI FLOOR REVERSE AND LIMIT SWITCH

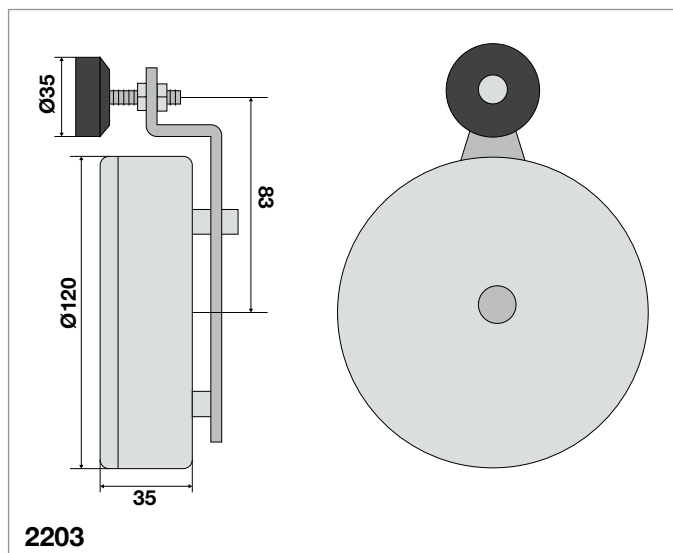
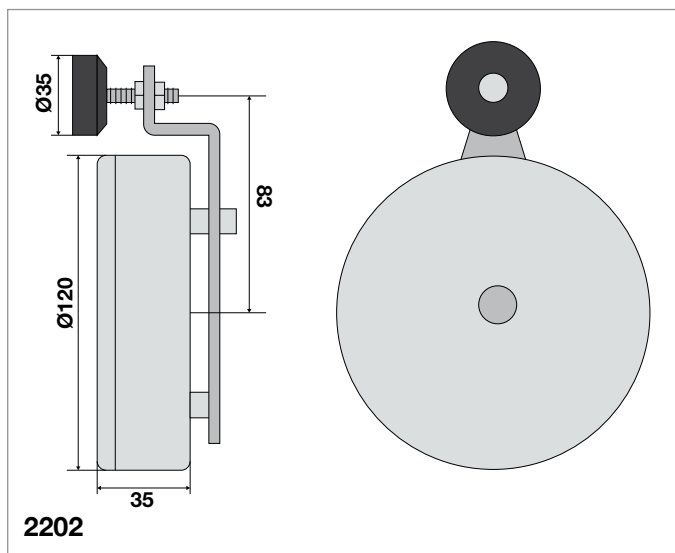
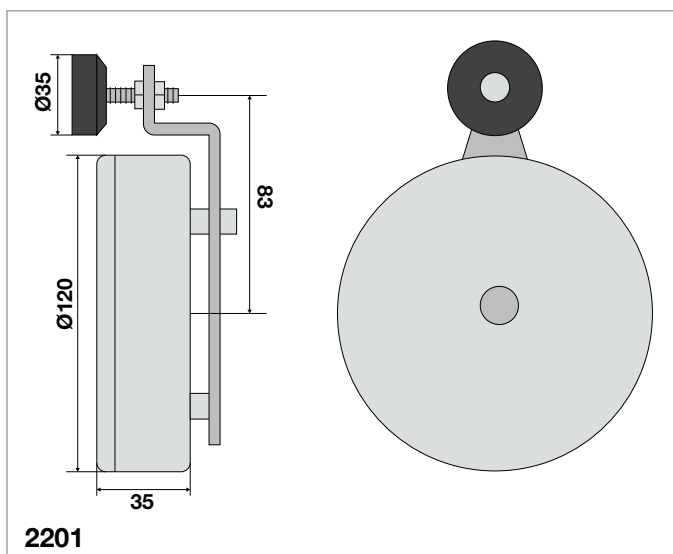
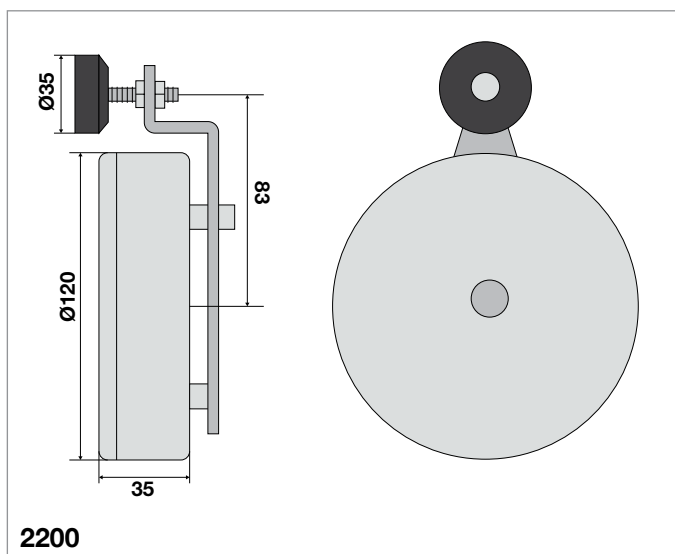

Codice / Code	Descrizione
2200	Commutatore di piano a 2 contatti BASSETTI B635B
2201	Commutatore di piano a 4 contatti BASSETTI B635A
2202	Finecorsa a 1 contatti BASSETTI B635M
2203	Finecorsa a 2 contatti BASSETTI B635C
22008	Rotella Ø 35 per commutatore e finecorsa BASSETTI

COMMUTATORI E FINECORSA FIAM FIAM FLOOR REVERSE AND LIMIT SWITCH



2013/1



2013/8



2014



2018

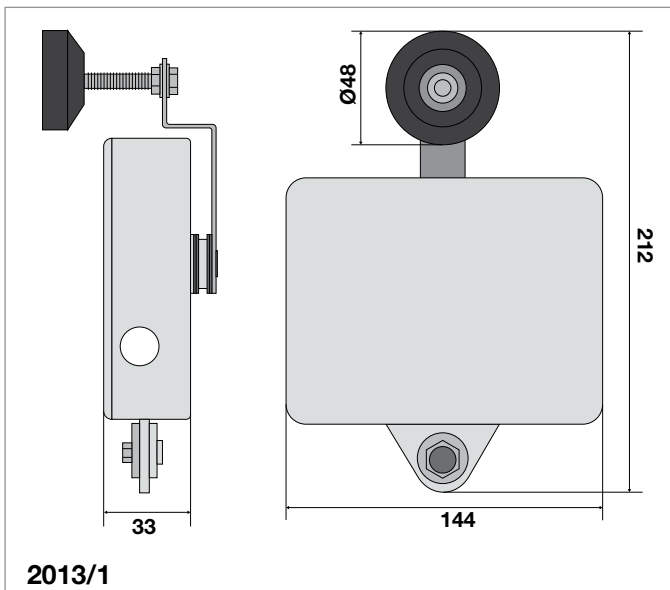

2013/1

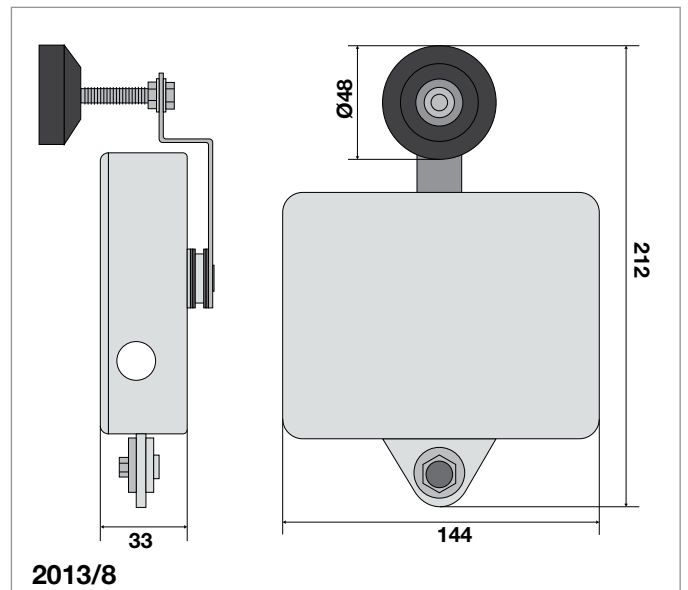

2013/8

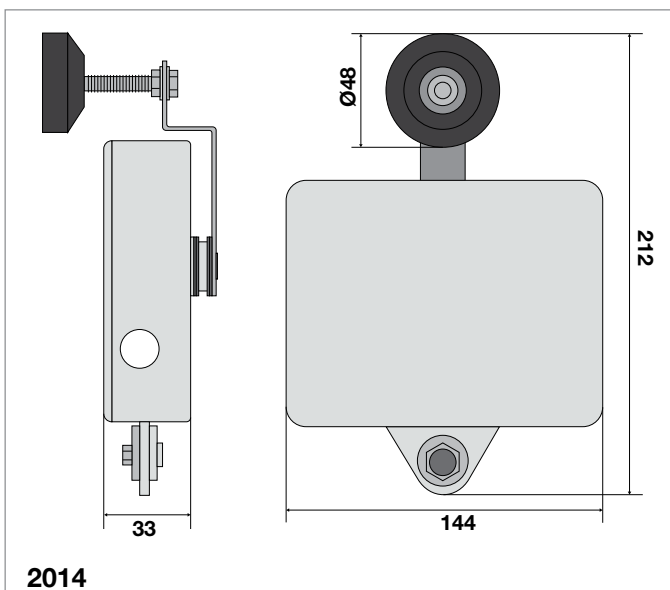

2014

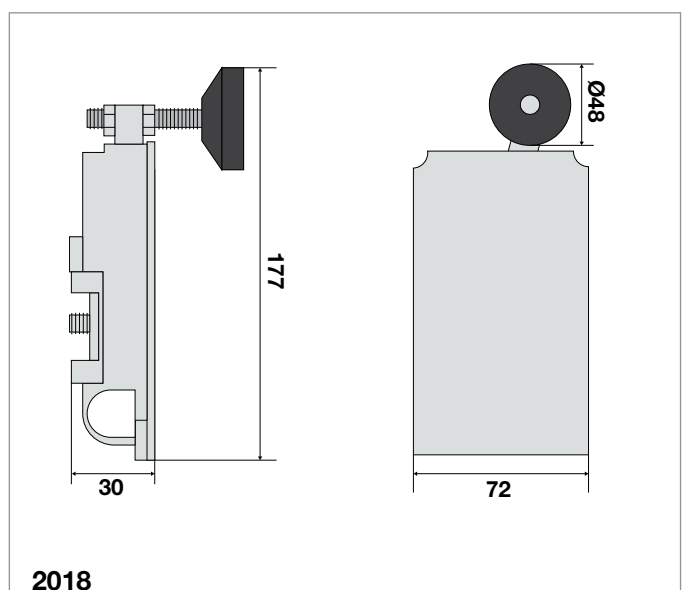

2018

Codice / Code	Descrizione
2013/1	Commutatore di piano a 7 contatti rotella Ø 48 con rosone in ceramica FIAM
2013/8	Commutatore di piano a 3 contatti rotella Ø 48 con rosone in ceramica FIAM
2014	Commutatore di piano a 5 contatti per impianto FIAM
2018	Finecorsa a 2 contatti per impianto FIAM tipo elettrico rotella Ø 48

RICAMBI PER COMMUTATORI FIAM SPARE PARTS FOR FIAM FLOOR REVERSE



2013/2



2013/4



2013/7



2013/6

2013/9

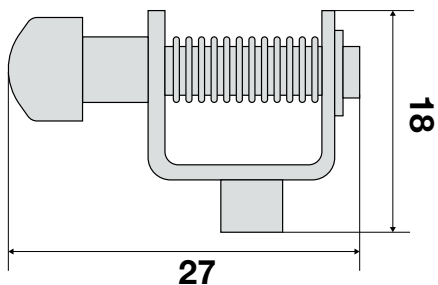

2013/2

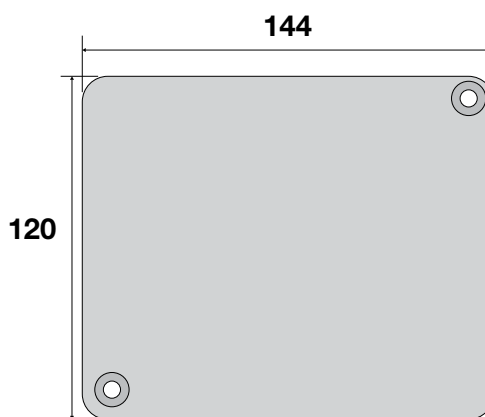

2013/4

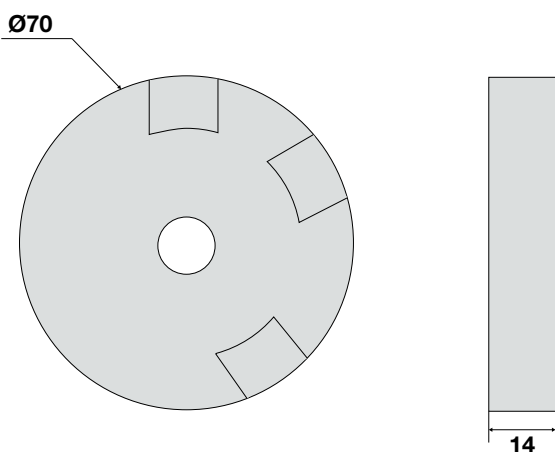

2013/9 2013/6

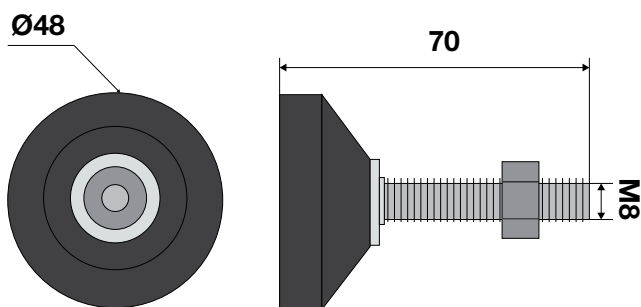

2013/7

Codice / Code	Descrizione
2013/2	Contatto a pistoncino commutatore FIAM
2013/4	Coperchio scatola commutatore FIAM
2013/6	Rosone in plastica 7 contatti commutatore FIAM
2013/7	Carrucola in gomma per leva commutatore FIAM
2013/9	Rosone in ceramica 3/5/7 contatti commutatore FIAM

COMMUTATORI E FINECORSA SAFOV - BASSETTI - FORSID
FLOOR REVERSE AND LIMIT SWITCH SAFOV - BASSETTI - FORSID

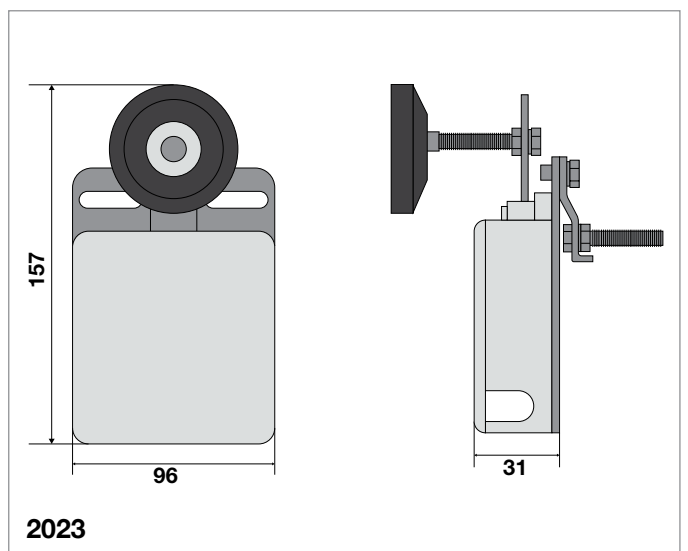
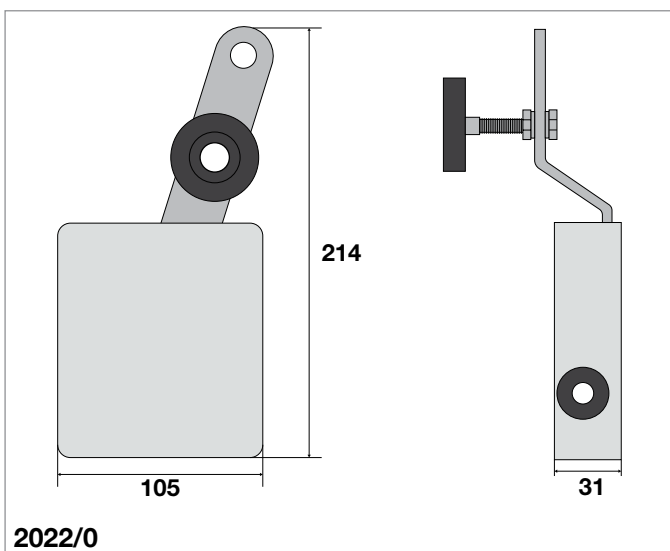
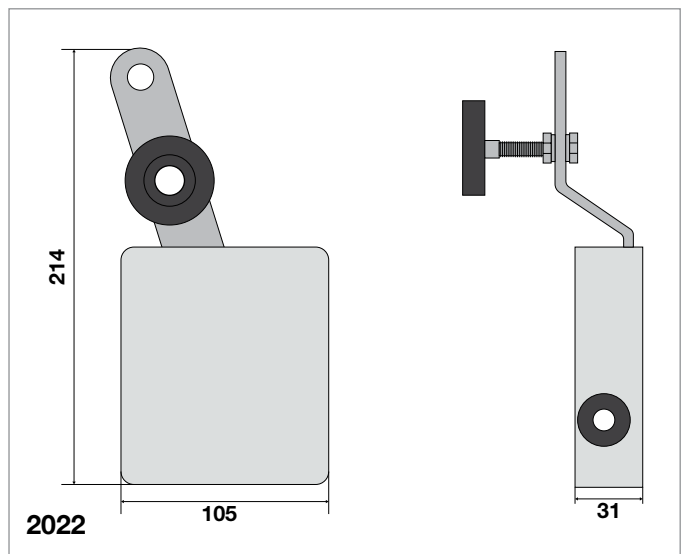
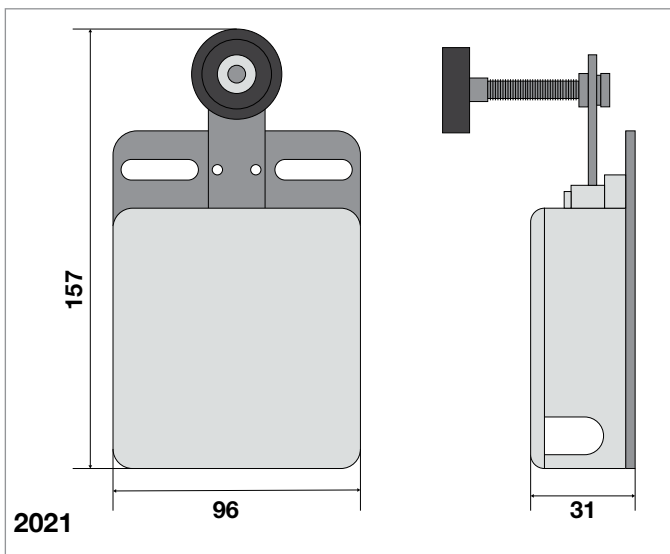

7

Codice / Code	Descrizione
2021	Commutatore di piano SAFOV con piastra
2022	Finecorsa SAFOV SX con piastra
2022/0	Finecorsa SAFOV DX con piastra
2023	Commutatore intercambiabile BASSETTI - FORSID rotella Ø 30 mm

RICAMBI SOLO PER "VECCHI" SAFOV ORIGINALI E FORSID
SPARE PARTS ONLY FOR "OLD" ORIGINAL SAFOV AND FORSID

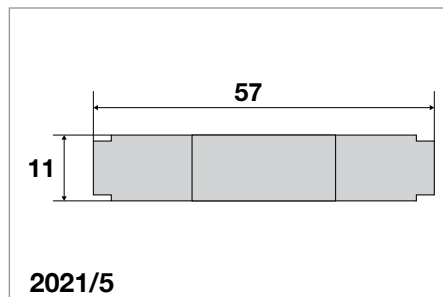
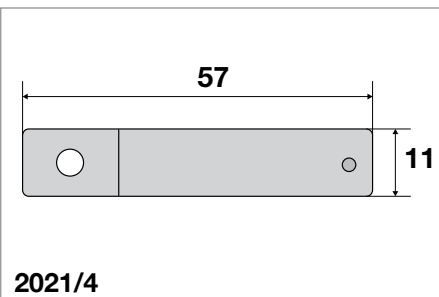
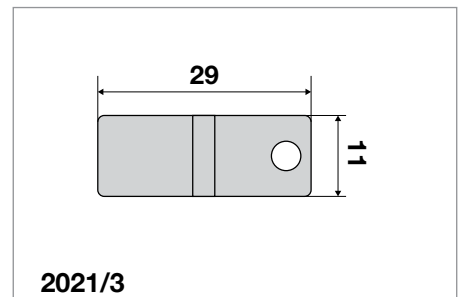
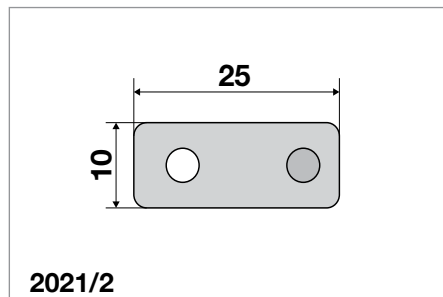
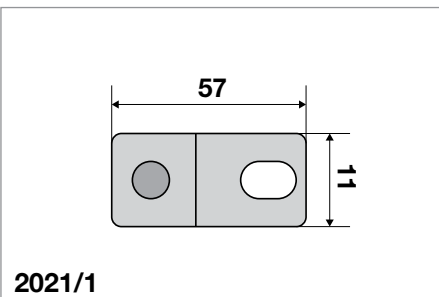

Codice / Code	Descrizione
2021/1	Lamella corta deviatore SAFOV
2021/2	Lamella corta SAFOV
2021/3	Lamella lunga deviatore SAFOV
2021/4	Lamella lunga SAFOV
2021/5	Molla di scambio deviatore SAFOV

**COMMUTATORI E FINECORSA SILVER SWITCH FORSID - MONITOR
FLOOR REVERSE AND LIMIT SWITCH SILVER FORSID - MONITOR**

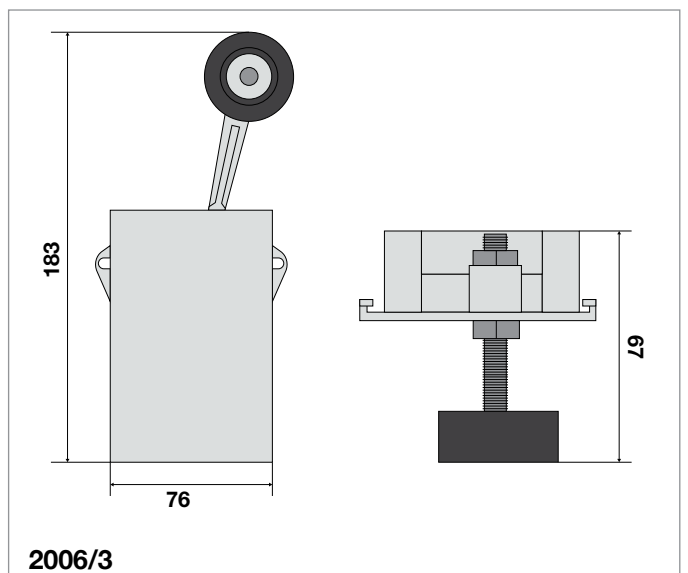
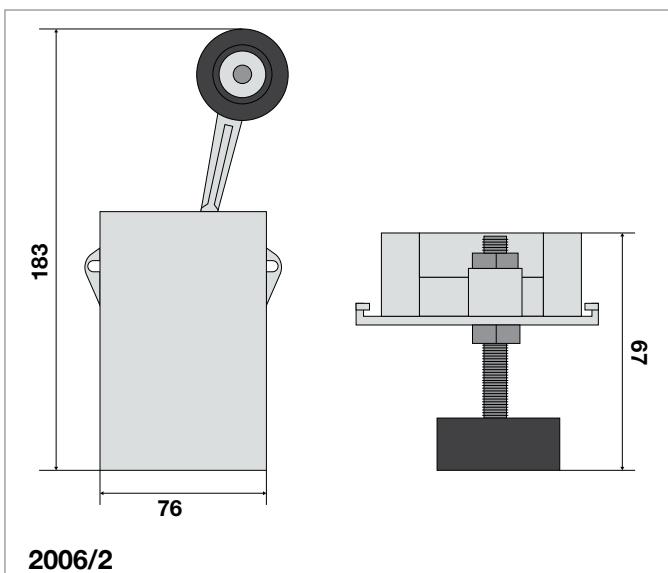
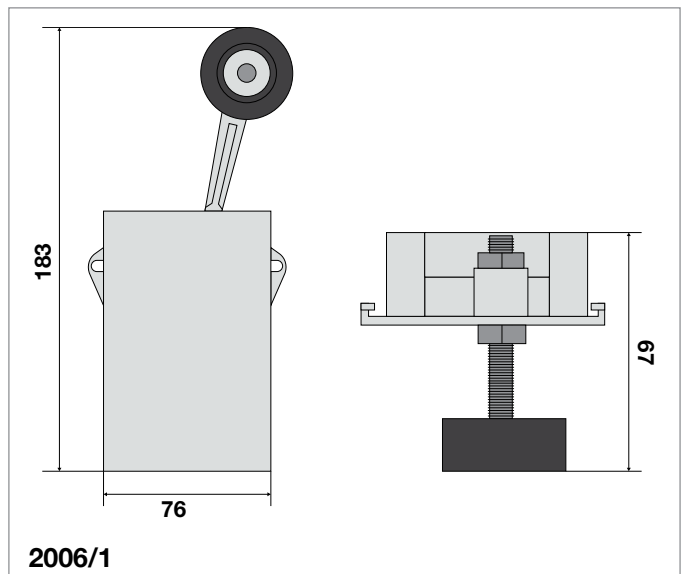
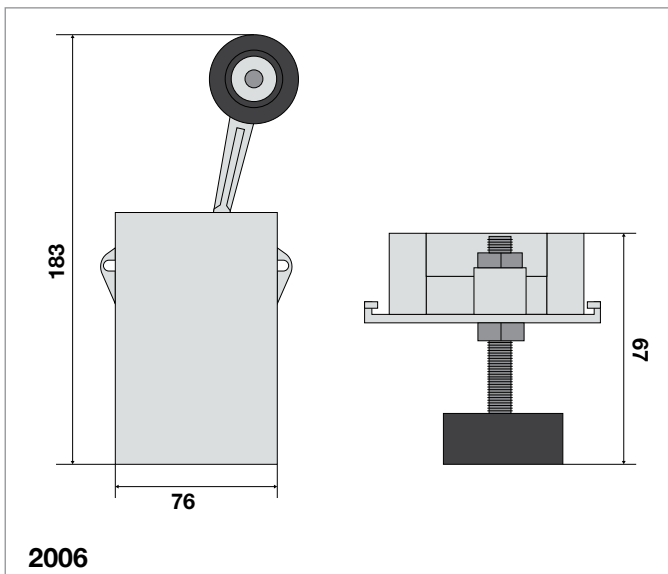

7

Codice / Code	Descrizione
2006	Commutatore di piano "SILVER SWITCH FORSID-MONITOR"
2006/1	Finecorsa DX "SILVER SWITCH FORSID-MONITOR"
2006/2	Finecorsa SX "SILVER SWITCH FORSID-MONITOR"
2006/3	Commutatore stabile 3 posizioni di piano "SILVER SWITCH FORSID-MONITOR"

SAGOME COMMUTAZIONE REVERSING CAM SHEET METAL

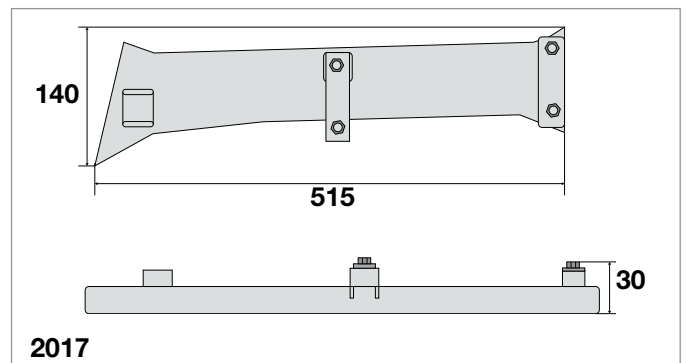
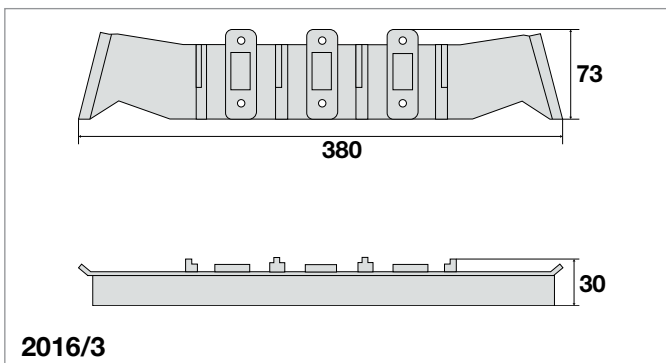
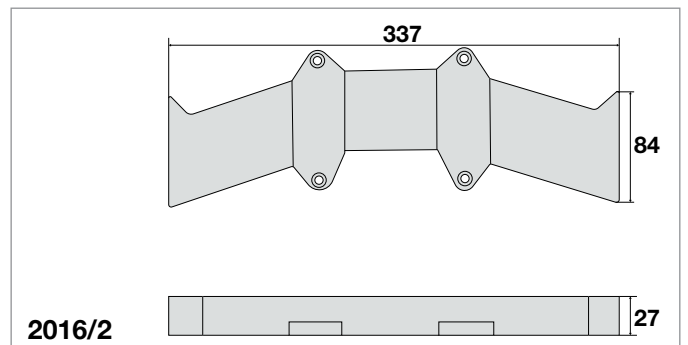
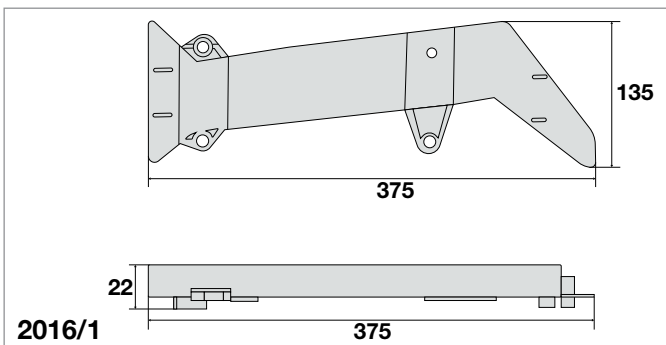
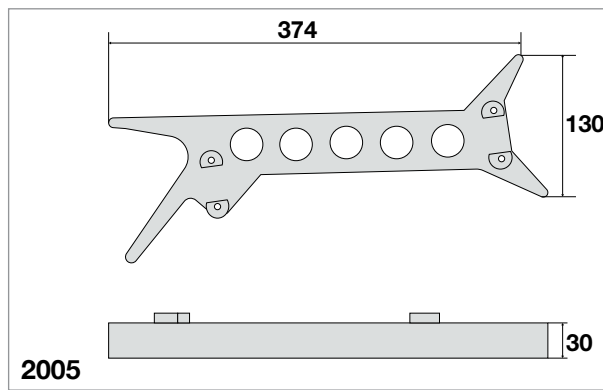
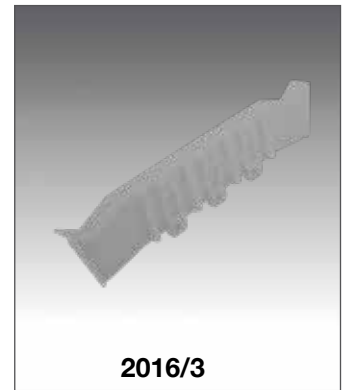

Codice / Code	Descrizione
2005	Coppia cammes in alluminio
2016/1	Sagoma in plastica per commutatore BASSETTI
2016/2	Sagoma in plastica di ripescaggio (tipo vecchio) BASSETTI
2016/3	Sagoma di commutazione per impianti oleodinamici FIAM
2017	Coppia cammes commutazione intercambiabile FIAM

IMPULSORI MAGNETICI E OTTICI MAGNETIC SENSOR AND OPTIC



3009



3018



3019



3020

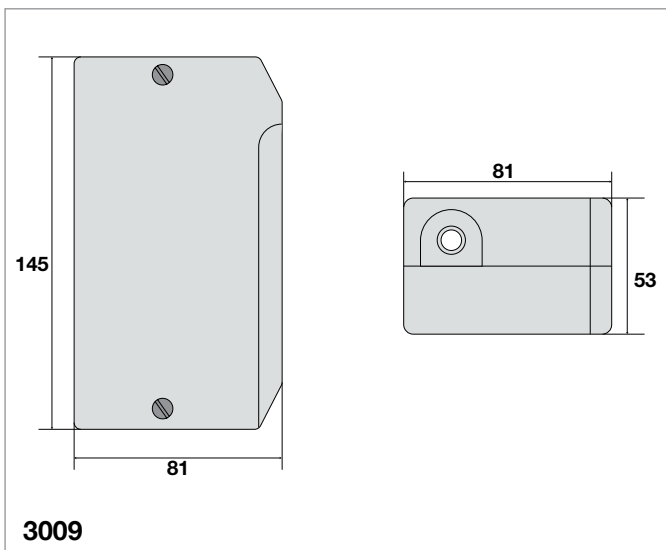

3009

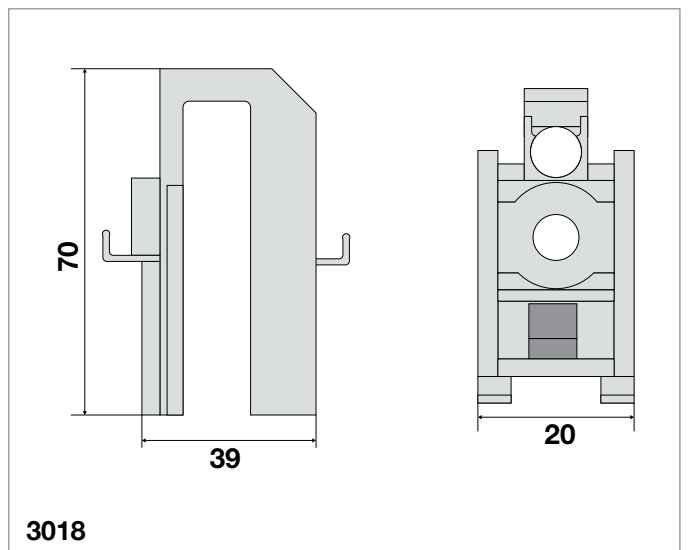

3018

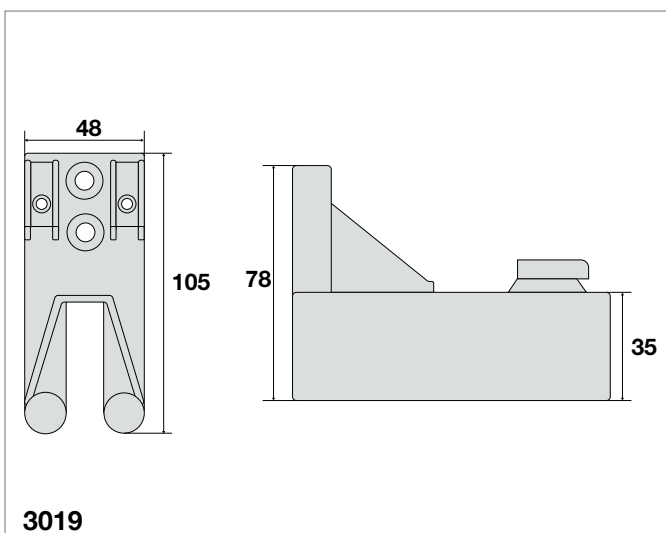

3019

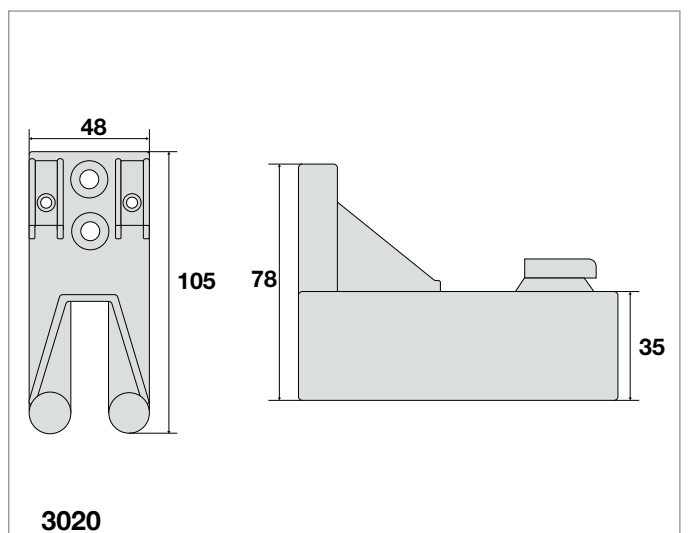

3020

Codice / Code	Descrizione
3009	Impulsore magnetico FORSID Attenzione: articolo in esaurimento NAC 11 - 30 - 31 mentre il NAC 33 3NC + 3NA + C é sempre in produzione
3018	Impulsore magnetico FALCONI L.70 mm
3019	Impulsore magnetico bollino rosso CNC
3020	Impulsore magnetico bollino verde CNA

IMPULSORI MAGNETICI MAGNETIC SENSOR

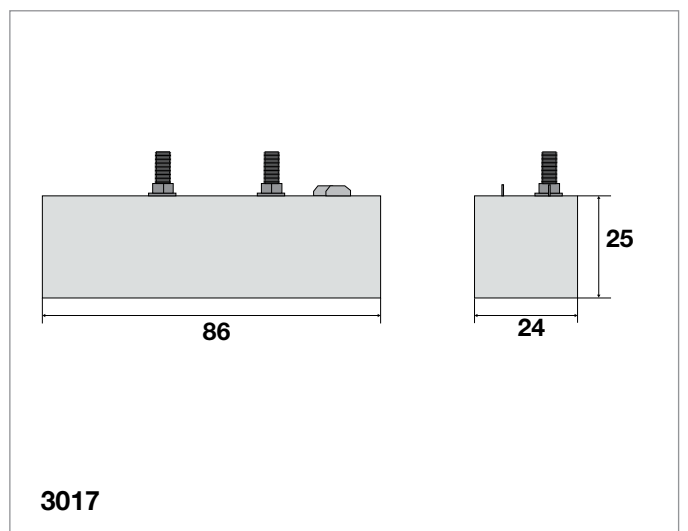
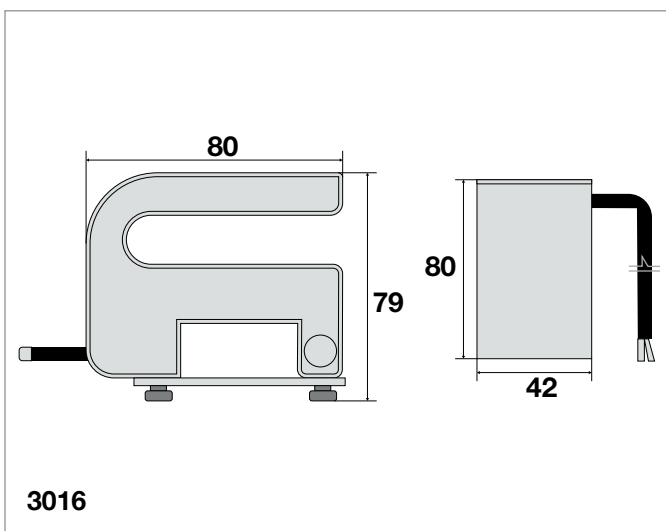
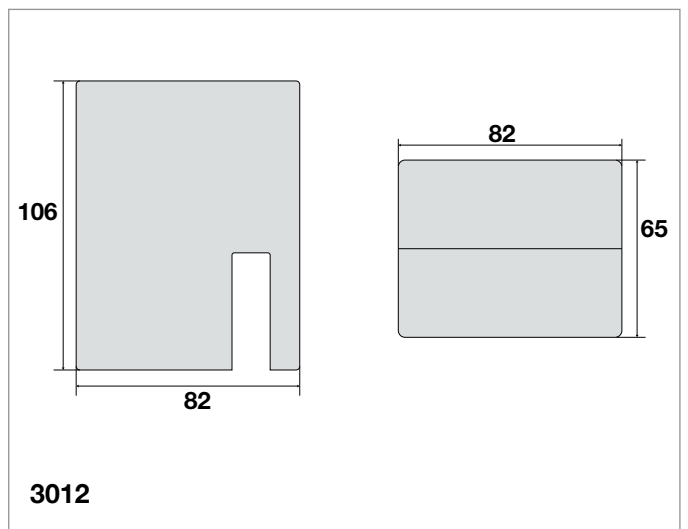
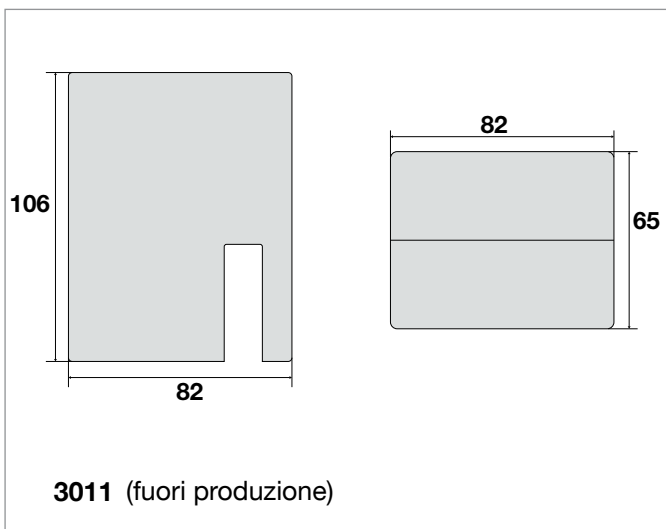
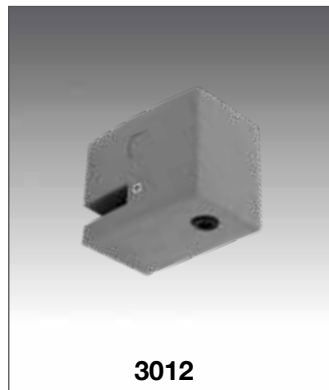

Codice / Code	Descrizione
3011	Impulsore magnetico SICEM 1 CNC + 1 CNA (fuori produzione)
3012	Impulsore magnetico SICEM 2 CNC + 2 CNA
3016	Impulsore magnetico FIAM
3017	Impulsore magnetico bistabile intercambiabile SCHINDLER

IMPULSORE MAGNETICO CILINDRICO CYLINDRICAL MAGNETIC SENSOR

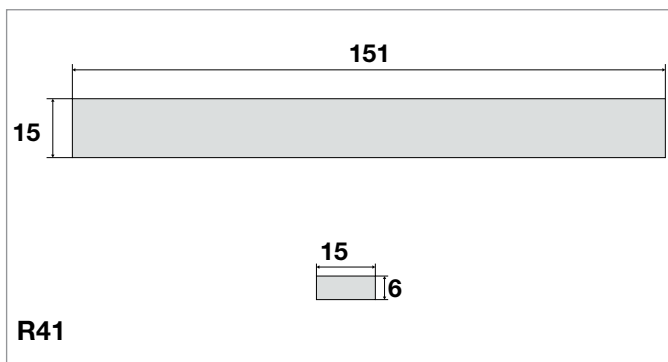
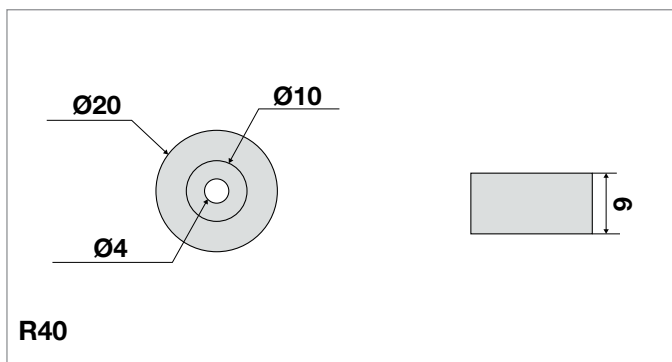
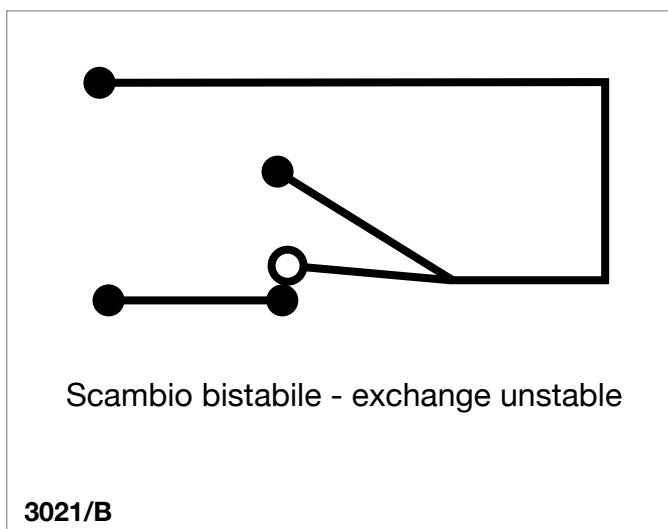
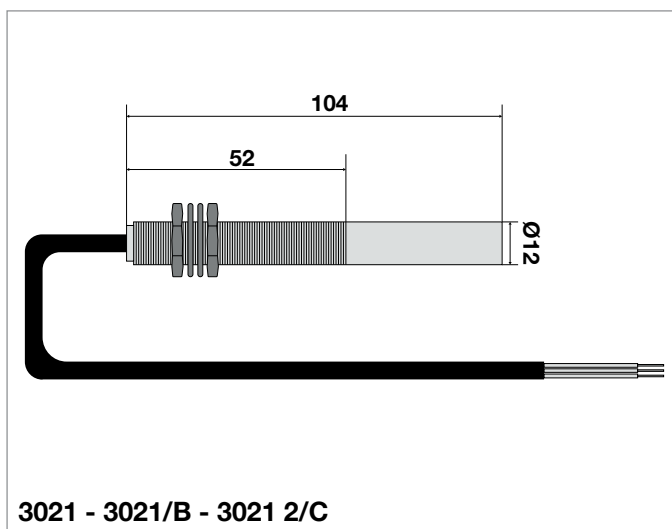
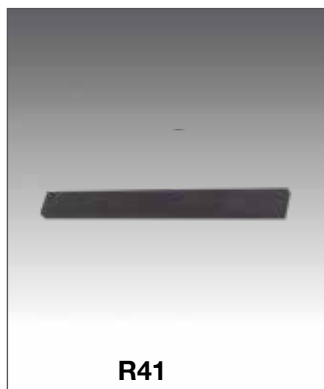
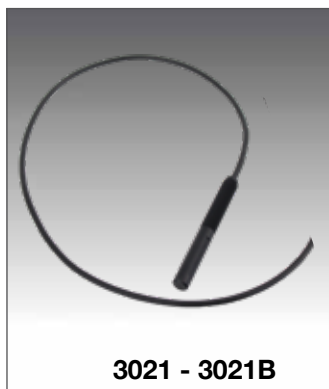

Codice / Code	Descrizione
3021	Impulsore magnetico cilindrico con cavo semi filettato M12 x 1 Max 220 V.CC 220 VAC 60 VA, diametro cavo 5 mm
3021 2/C	Impulsore magnetico cilindrico con cavo semi filettato M12 x 1 Max 200 V.CC 250 VAC 60 VA, diametro cavo 5 mm NO + NC
3021/B	Impulsore magnetico bistabile con cavo semi filettato M12 x 1 Max 250 V.CC 250 VAC 100 VA
R40	Magnete tondo diametro 20 mm
R41	Magnete rettangolare 151 x15 x 6 mm

IMPULSORE MAGNETICO CILINDRICO IN OTTONE FILETTATO

Ø 10 x L.85 mm

CYLINDRICAL MAGNETIC SENSOR IN BRASS THREADED Ø10 x L.85 mm



A

- Tensione operativa max 250 Vca
- Corrente commutabile max 3 A
- Potenza commutatori 120 W/VA
- Lunghezza cavo 1500 mm
- Marchio CE - IP67

- *Switching voltage max 250 Vca*
- *Switching current max 3 A*
- *Switching power 120 W/VA*
- *Cable length 1500 mm*
- *Registered CE - IP67*

Codice / Code	Descrizione
3022	Impulsore 1 N.A 2 fili
3023	Impulsore 1 N.C azionamento polo nord
3024	Impulsore 1 N.C azionamento polo sud
3025	Impulsore bistabile sud apre - nord chiude

B

- Tensione operativa max 250 Vca
- Corrente commutabile max 1 A
- Potenza commutatori 60 VA
- Lunghezza cavo 1500 mm
- Marchio CE

- *Switching voltage max 250 Vca*
- *Switching current max 1A*
- *Switching power 60 VA*
- *Cable length 1500 mm*
- *Registered CE*

Codice / Code	Descrizione
3026	Impulsore scambio 3 fili

IMPULSORE MAGNETICO CILINDRICO CYLINDRICAL MAGNETIC SENSOR

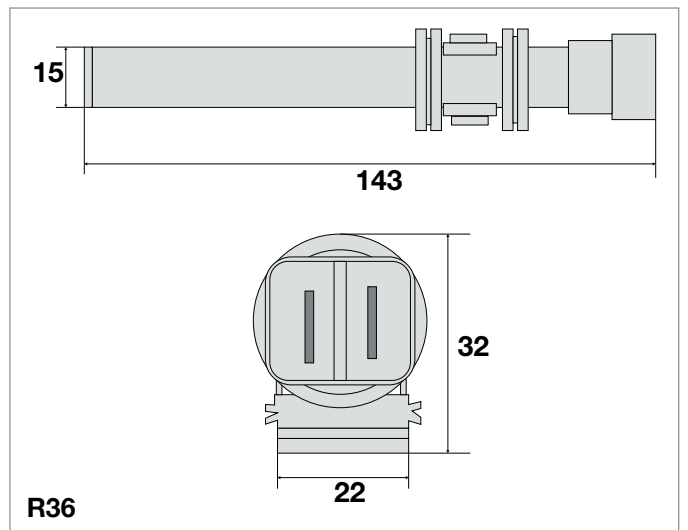
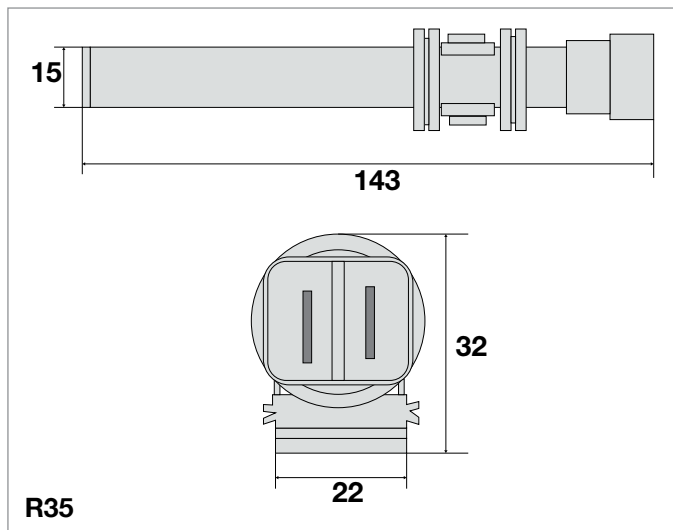
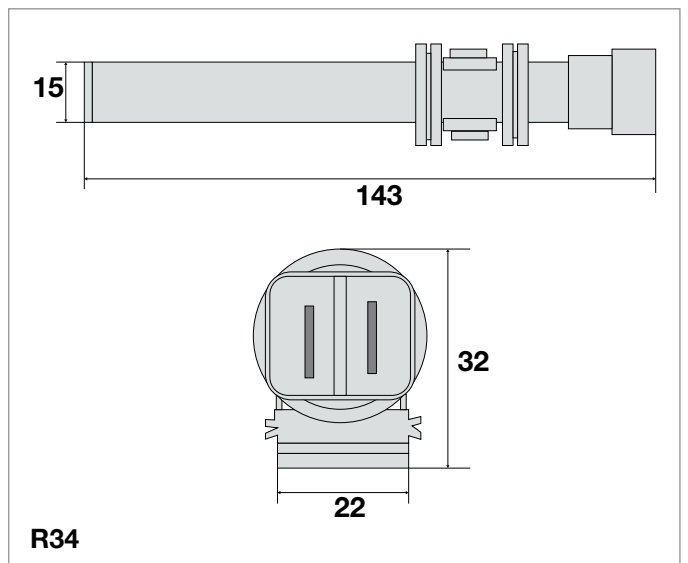
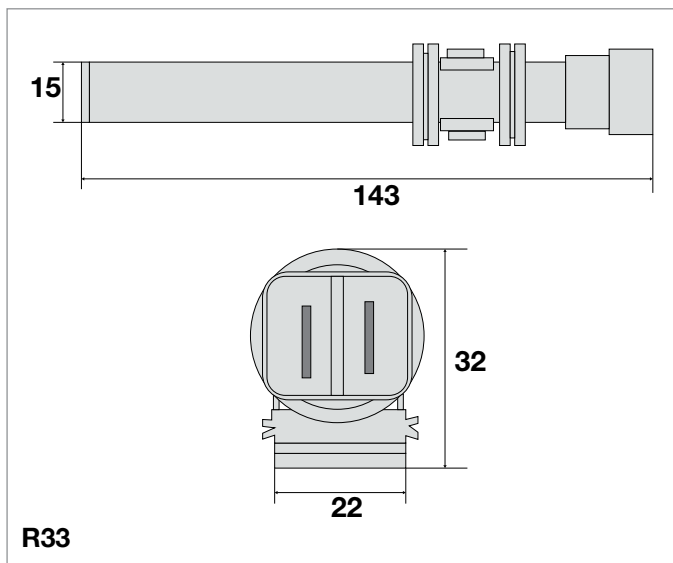
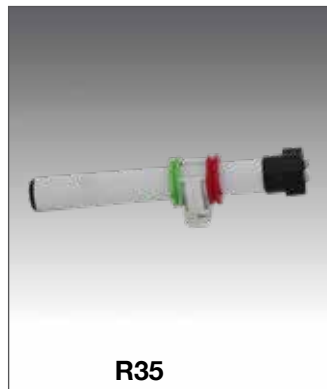
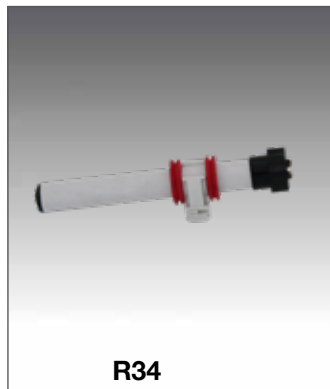
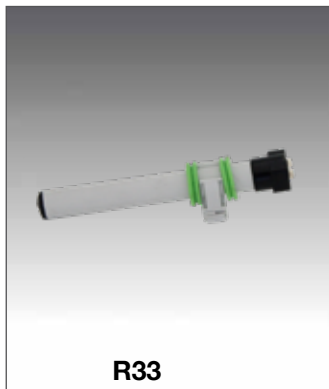

Codice / Code	Descrizione
R33	Impulsore magnetico anello verde NA
R34	Impulsore magnetico anello rosso NC
R35	Impulsore magnetico anelli rosso + verde bistabile
R36	Impulsore magnetico NA + bistabile (4 fili)

LAMA TAGLIAFLUSSO STRAIGHT ADJUSTABLE INDUCTION PLATE



7

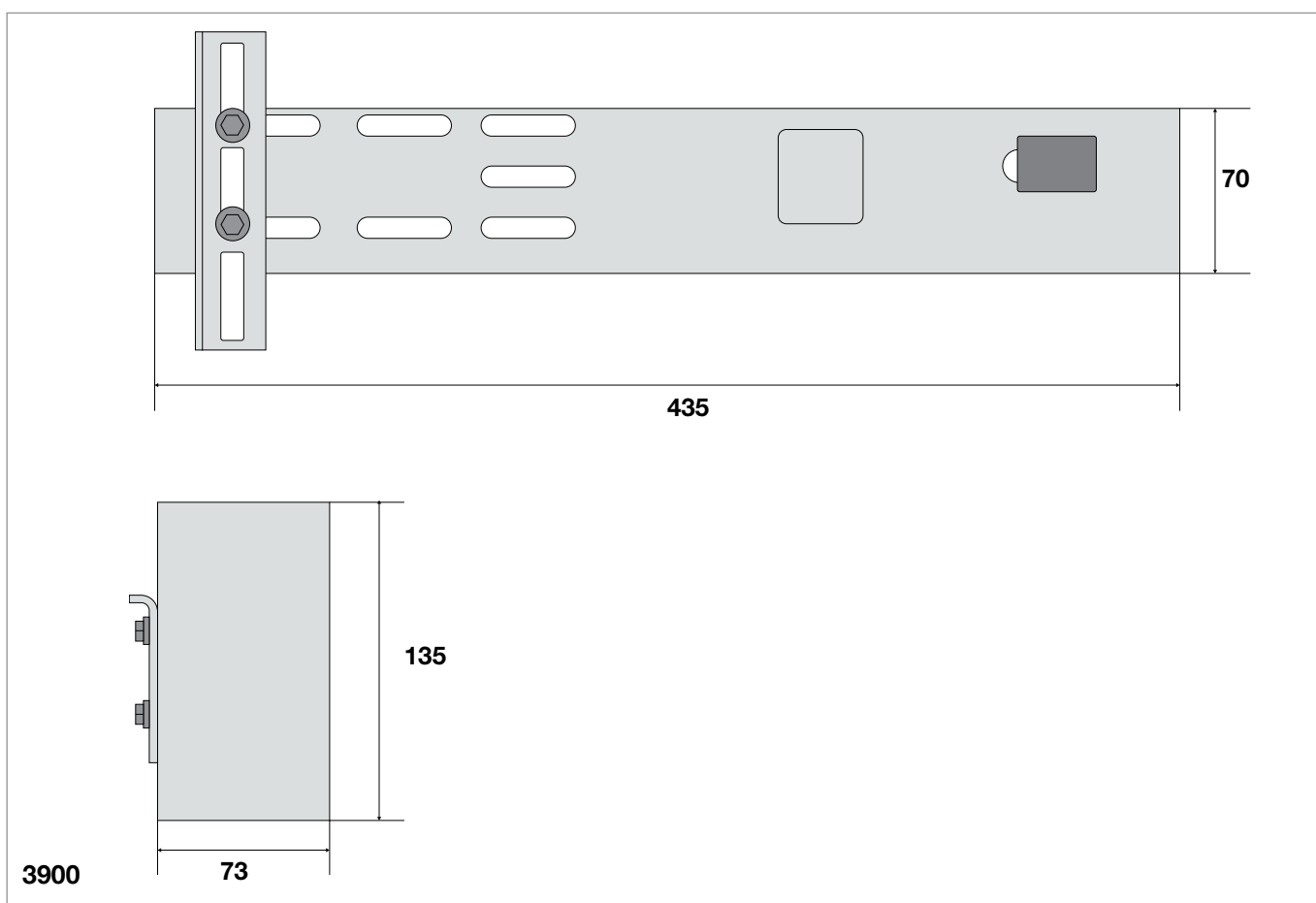

Codice / Code	Descrizione
3900	Lama tagliaflusso per impulsore magnetico

DISPOSITIVO DI AUTOLIVELLAMENTO PER IMPIANTI OLEODINAMICI AUTOMATIC SELF-LEVELLING DEVICE



20020/A



2024



2025



2026

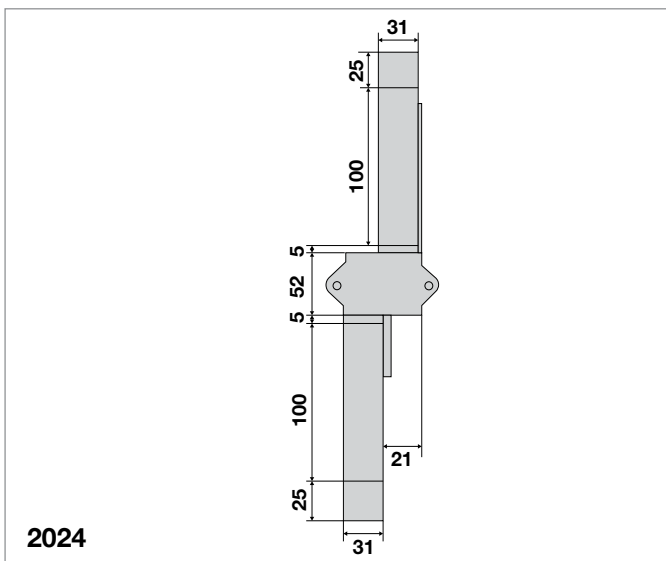

2024

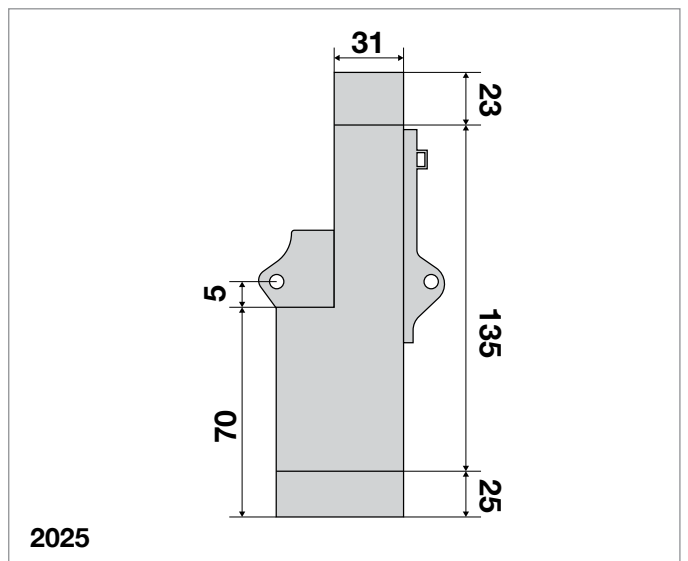

2025

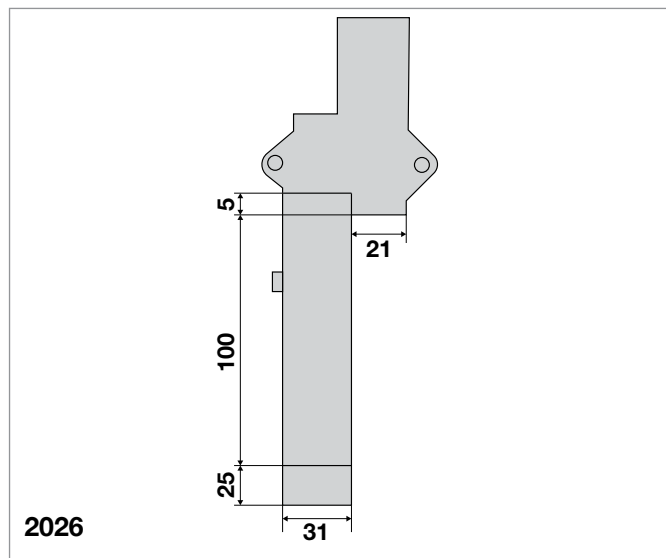

2026

7

Codice / Code	Descrizione
20020/A	Dispositivo di autolivellamento 48/60V 1 contatto a striscio
2024	Scivolo 2 piste
2025	Scivolo doppia pista
2026	Scivolo a 1 pista

NOTE

MOLLE PER PORTE DI PIANO, CINGHIA BANDELLA RACHIAMO PORTA SCHINDLER PORTINE DI CABINA, OPERATORIE SOSPENSIONI, CERNIERE PORTE DI PIANO E CABINA, MANIGLIE, CORNICI, TAMPONI BATTUTA PORTA DI PIANO E PORTINE CABINA, ANGOLARE ALTO E BASSO PORTINE CABINA ATTREZZO TIPO MOLLA

SPRINGS FOR LANDING DOORS - CABIN DOORS - OPERATORS AND HANGER, BELT SCHINDLER, HINGES FOR LANDING AND CABIN DOOR, HANDLES, FRAMES, BUFFER PADS FOR LANDING AND CABIN DOOR, HIGH AND LOW CORNER FOR CABIN DOOR TYPE SPRING

Attrezzo tiramolla FIAM	8.12
<i>Spring Tightener FIAM</i>	
Bandella di richiamo tiramolla in plastica per porte di piano SCHINDLER	8.12
<i>Restraint belt for semi-automatic door SCHINDLER</i>	
Cerniera a libro con collo per portine di cabina	8.37
<i>Folding hinges for cabin door</i>	
Cerniere a libro piane per portine di cabina	8.35 - 8.36
<i>Folding hinges for cabin door</i>	
Cerniere a libro portine cabina	8.32 - 8.33
<i>Hinges for cabin door</i>	
Cerniere PAUMELLES per portine di cabina	8.34
<i>PAUMELLES hinges for cabin door</i>	
Cerniere portine cabina e porta di piano SCHINDLER e BASSETTI	8.31
<i>Hinges for cabin door and landing door SCHINDLER and BASSETTI</i>	
Cornici in alluminio per porte a battente di piano	8.41
<i>Aluminium frames for landing door</i>	
Cuscinetto a rullo porte Kramer	8.30
<i>Kramer door roller bearing</i>	
Cuscinetto reggispinta porte a battente FIAM	8.30
<i>Thrust bearing sealing FIAM</i>	
Dispositivo di richiamo porta di piano SCHINDLER	8.12
<i>Return spring for semiautomatic landing door SCHINDLER</i>	
Fermi alti e bassi e attacchi molle per portine di cabina	8.30
<i>Rubber door stop long, short and spring connection for cabin door</i>	

Kit blocchetto + falsamaglia + catena TF	8.6
<i>TF, operator steel chain + bolt + false mesh</i>	
Maniglia Dictator ST	8.38
<i>Dictator handle ST</i>	
Maniglia Dictator S	8.39
<i>Dictator handle S</i>	
Maniglie per porte di piano a battente tubolari e ad incasso, standard, SCHINDLER, in plastica BASSETTI	8.40
<i>Handles for swing door, standard tubular for SCHINDLER, in plastic for BASSETTI, also concealed</i>	
Molla a lamella per porte BASSETTI	8.12
<i>Spring leaves for door BASSETTI</i>	
Molla a torsione	8.10 - 8.11
<i>Torsion spring</i>	
Molla a trazione per nucleo teleruttore "NF41"	8.23
<i>Panel closing spring for remote control switch core "NF41"</i>	
Molla balestra per motore operatore BASSETTI	8.19
<i>Leaf Spring for operator motor BASSETTI</i>	
Molla compressione pattino elettromagnetico LG47 FIAM	8.20
<i>Compression spring electromagnetic cam LG47 FIAM</i>	
Molla FIAM per valvola salita V3-V4	8.22
<i>Spring FIAM for slide valve V3-V4</i>	
Molla OMEGA martelletto selettore SCHINDLER	8.22
<i>Spring OMEGA hammer switch SCHINDLER</i>	
Molla per gancio operatore SABIEM	8.19
<i>Spring for hook operator SABIEM</i>	
Molla per pattino arcate FIAM BL - BLP	8.23
<i>Spring for cam frame FIAM BL - BLP</i>	
Molla per pattino retrattile SCHINDLER	8.20
<i>Spring retiring cam SCHINDLER</i>	

Molla per catenacci blocco SCHINDLER	8.19
<i>Spring for threaded block SCHINDLER</i>	
Molla per galoppino FIAM	8.16
<i>Belt tightener spring FIAM</i>	
Molla per accoppiamento sospensioni tipo B FIAM (sinistra, destra)	8.16
<i>Torsion spring for coupling hanger type B FIAM (right, left)</i>	
Molla per richiamo porte semiautomatiche FIAM	8.7
<i>Spring for return semiautomatic door FIAM</i>	
Molla per porte a battente BASSETTI a compressione	8.7
<i>Springs for swing door BASSETTI compression</i>	
Molla per porta a battente FIAM con perno filettato	8.6
<i>Spring for swing door FIAM with filleted pivot</i>	
Molla ponte catenaccio serratura HE2 SCHINDLER	8.23
<i>Spring door lock latch bridge HE2 SCHINDLER</i>	
Molla porte serrature porte automatiche SCHINDLER (SX, DX)	8.16
<i>Spring door lock for automatic SCHINDLER (right and left)</i>	
Molla puntone di spunto automatismo A-B FIAM.....	8.17
<i>Portable strut spring for automatic A-B FIAM</i>	
Molla QKS 9 (SX, DX)	8.18
<i>Spring QKS 9 (RX, LX)</i>	
Molla scrocco automatismo FIAM	8.18
<i>Spring contact FIAM</i>	
Molla sostegno elettromagnete argani 27-3N-5N FIAM	8.20
<i>Spring support electromagnet Traction Machine 27-3N-5N FIAM</i>	
Molla tenditore operatore SCHINDLER	8.18
<i>Spring for operator SCHINDLER</i>	
Molla TF	8.6
<i>Spring TF</i>	

Molla tubolare da incasso e sovrapposizione DICTATOR E16 - E22	8.25
<i>Concealed and invisible jamb closer for mounting into the door leaf DICTATOR E16 - E22</i>	
Molla tubolare da incasso DICTATOR D2A - D4	8.27
<i>Closing spring with operating arm D2A / D4</i>	
Molle a lamella	8.12
<i>Spring in leaves</i>	
Molle a trazione operatori / sospensioni A/2PO FIAM Ø21, Ø15 varie lunghezze	8.14 - 8.15
<i>Panel Closing Spring operator / hanger Ø21, Ø15 in variety of length</i>	
Molle attacco funi	8.24
<i>Rope attachment rod spring</i>	
Molle da sovrapposizione DICTATOR PICCOLO	8.26
<i>Closing spring PICCOLO</i>	
Molle pattino retrattile BASSETTI (DX, SX)	8.20
<i>Spring retiring cam BASSETTI (RX, LX)</i>	
Molle per automatismo FIAM	8.17
<i>Spring for automatic FIAM</i>	
Molle per limitatori di velocità SCHINDLER, FIAM	8.21
<i>Springs for over speed governor SCHINDLER, FIAM</i>	
Molle per portine di cabina STANDARD, FIAM, BASSETTI	8.13
<i>Spring for cabin door STANDARD, FIAM, BASSETTI</i>	
Molle per porta a battente FALCONI abbinata a chiudiporta FALCONI	8.7
<i>Spring for landing door FALCONI coupling with FALCONI door closer</i>	
Molle porte a battente di piano a torsione	8.9
<i>Springs for landing door with torsion</i>	
Molle richiamo barra portacatenacci sospensioni tipo S FIAM (destra, sinistra)	8.16
<i>Return spring threaded door latch hanger FIAM type S (right, left)</i>	
Molle SAFOV, FIAM	8.10 - 8.11
<i>Spring SAFOV, FIAM</i>	

Molle TESIO - OTIS	8.6
<i>Spring TESIO - OTIS</i>	
Molle VICINI per battenti tipo V	8.8
<i>Spring VICINI for swing door type V</i>	
Pacco di molle torsione per lamellari porte CANOSSA	8.12
<i>Torsion spring for hinged lift doors CANOSSA</i>	
Perno aggancio porta FIAM DM.1101 (destra, sinistra)	8.28
<i>Pivot hook door FIAM C (right, left)</i>	
Perno superiore con scanalatura per tensione molla	8.28
<i>Superior pivot with groove for spring tension</i>	
Tamponi di battuta per porte di piano TF, BASSETTI, VICINI	8.29
<i>Door stop buffer for landing door TF, BASSETTI, VICINI</i>	

Note: I componenti sul catalogo con riportata una specifica marca di ascensore sono utilizzati abitualmente solo da questa marca. I particolari senza marca sono utilizzati da più marche di ascensori.

Note: The components in the catalogue with a specific lift brand are usually used only by the brand. Unbranded parts are used by multiple lift brands.

MOLLE PORTE A BATTENTE DI PIANO A TRAZIONE TRACTION SPRINGS FOR LANDING DOORS

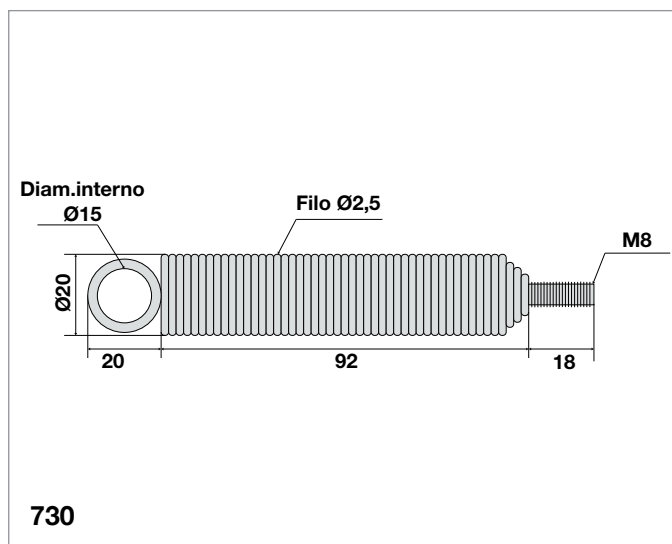
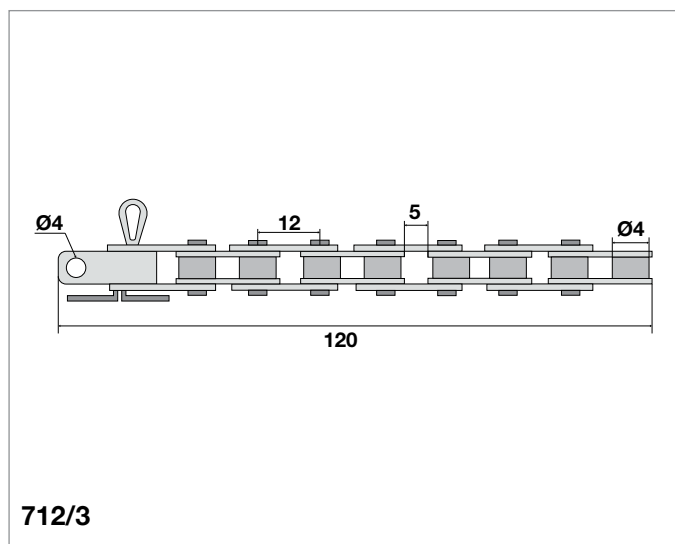
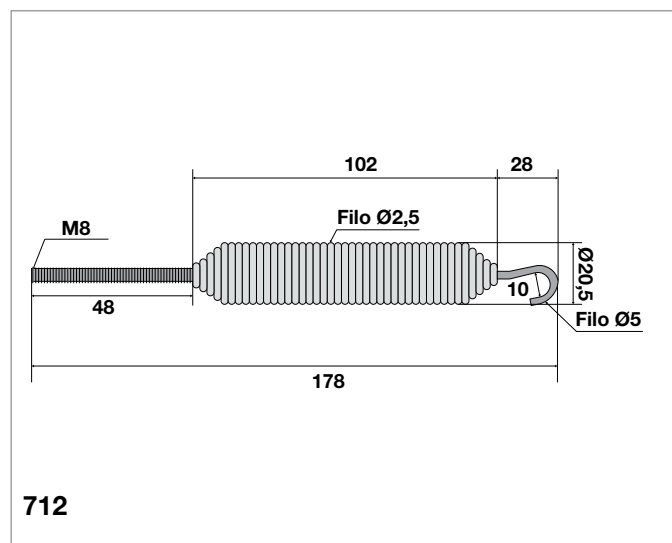
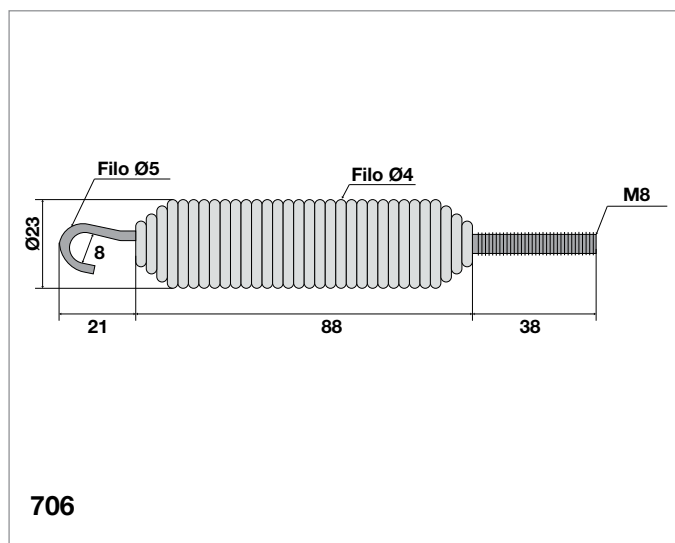
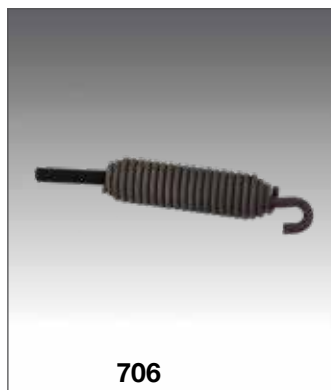

Codice / Code	Descrizione
706	Molla per porta a battente FIAM con perno filettato M8
712	Molla TF
712/3	Kit catena + blocco + falsamaglia TF
730	Molla porta a battente TESIO - OTIS
729/1	Bussola per kit falsamaglia TF

MOLLE PORTE A BATTENTE DI PIANO A TRAZIONE E COMPRESSIONE TRACTION AND PRESSURE SPRINGS FOR LANDING DOORS

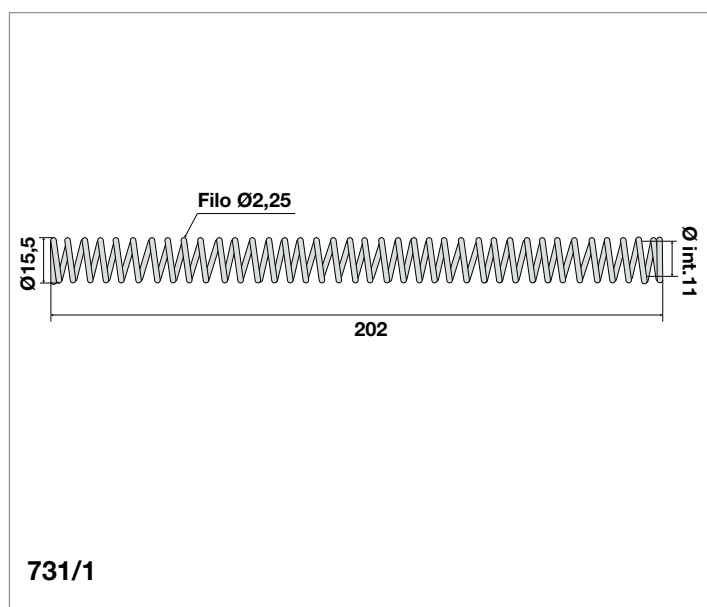
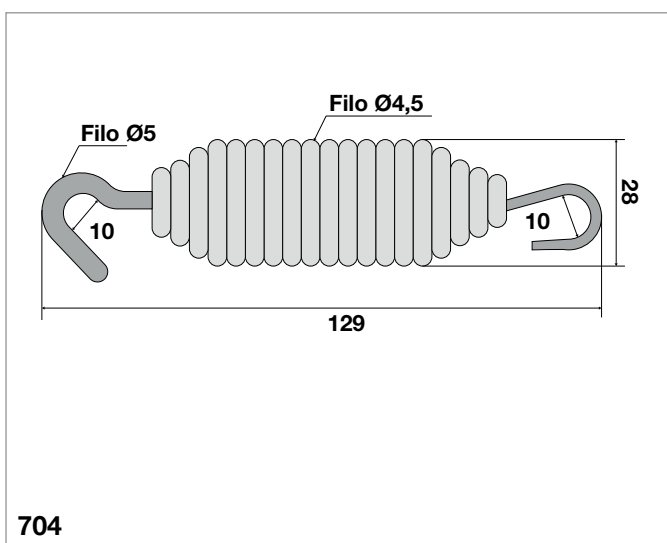
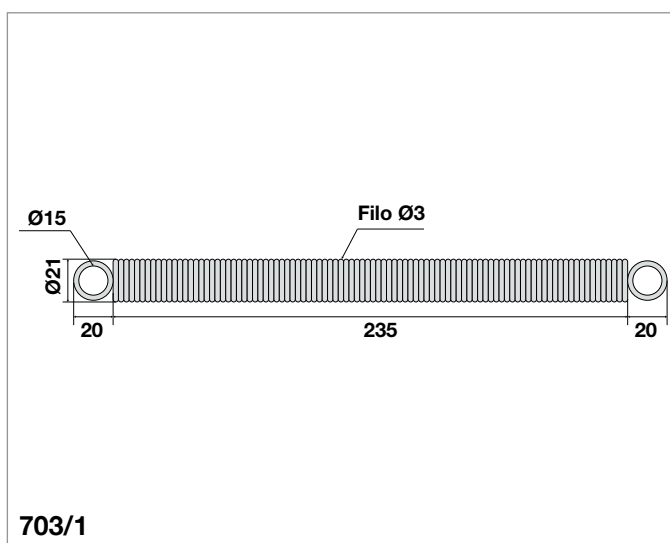
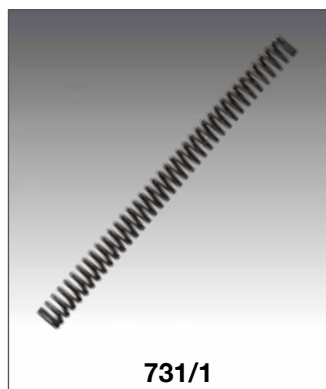

Codice / Code	Descrizione
703/1	Molla per porta a battente FALCONI abbinata a chiudiporta FALCONI cod.203089
704	Molla per richiamo porte semiautomatiche FIAM
731/1	Molla per porte a battente BASSETTI a compressione

MOLLE PORTE A BATTENTE DI PIANO A TRAZIONE TRACTION SPRINGS FOR LANDING DOORS

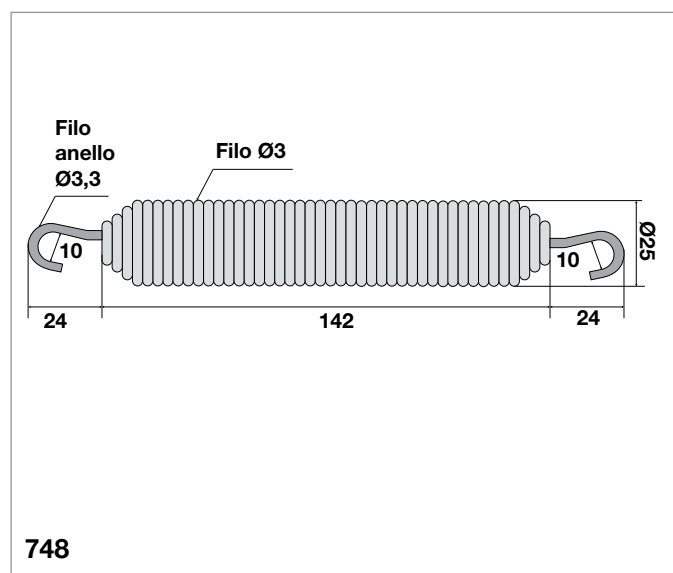
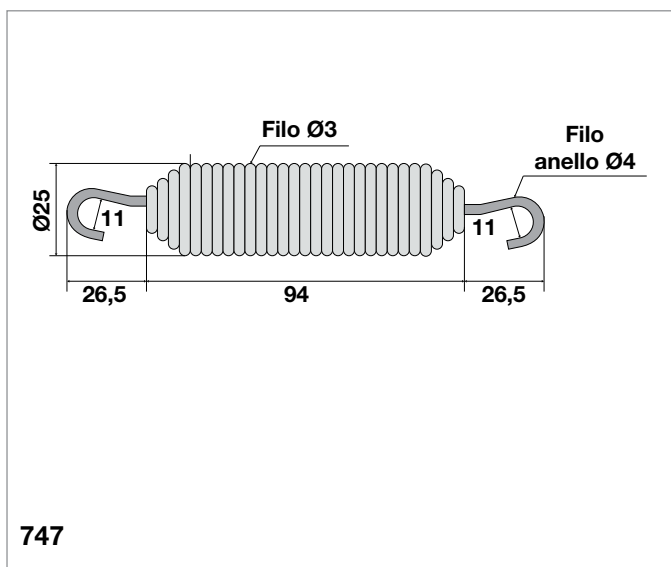
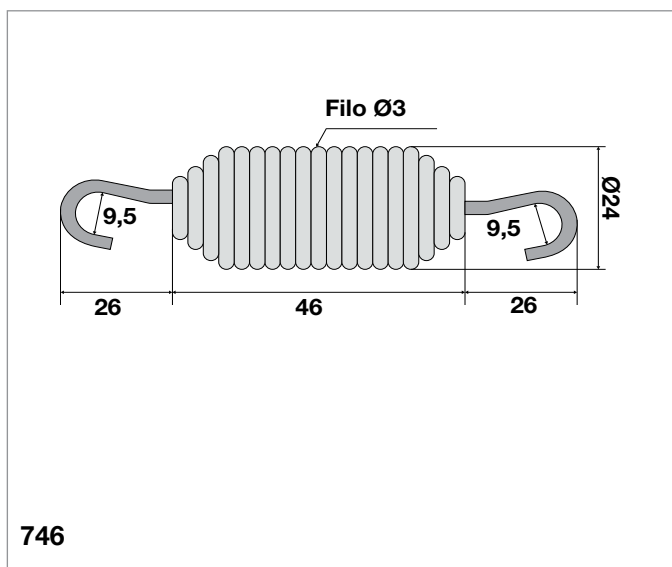
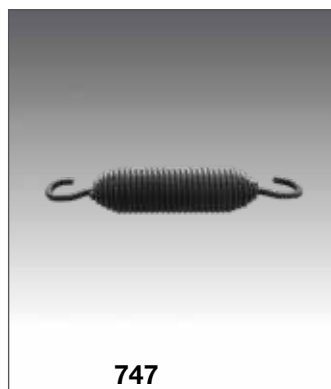

Codice / Code	Descrizione
746	Molla per porta a battente VICINI tipo V L.90 mm
747	Molla per porta a battente VICINI tipo V L.135 mm
748	Molla per porta a battente VICINI tipo V L.190 mm

MOLLE PORTE A BATTENTE DI PIANO A TORSIONE TORSION SPRINGS FOR LANDING DOORS

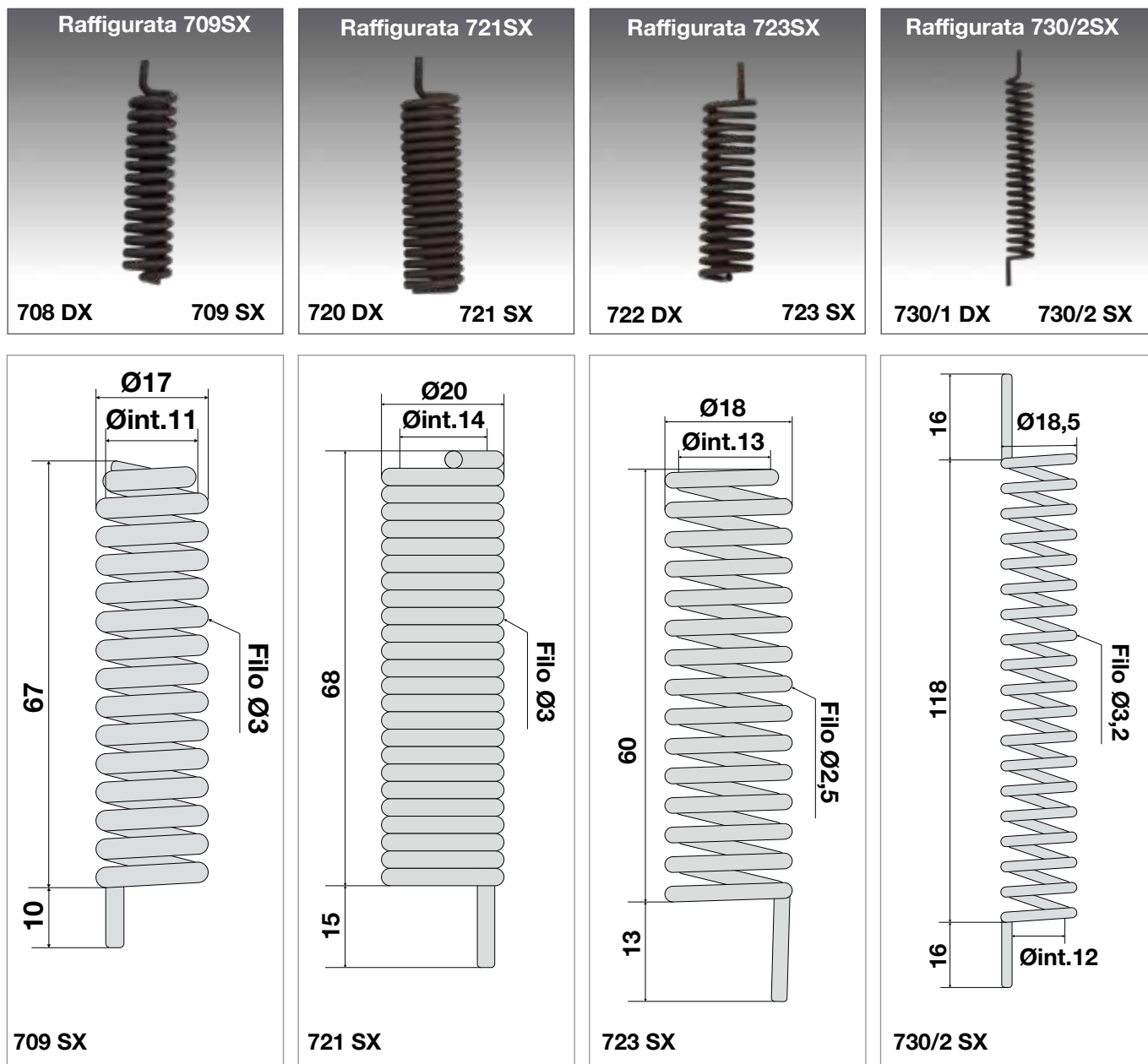

Codice / Code	Descrizione
708	Molla destra
709	Molla sinistra
720	Molla destra
721	Molla sinistra
722	Molla destra
723	Molla sinistra
730/1	Molla destra
730/2	Molla sinistra

ATTENZIONE SOLO PER MOLLE A TORSIONE CONSIDERARE CHE LE MOLLE DESTRE SONO PER PORTE CON CERNIERA A SINISTRA VISTE DAL PIANEROTTOLO, E LE SINISTRE PER PORTE CON CERNIERE A DESTRA VISTE DAL PIANEROTTOLO.

MOLLE PORTE A BATTENTE DI PIANO A TORSIONE TORSION SPRINGS FOR LANDING DOORS

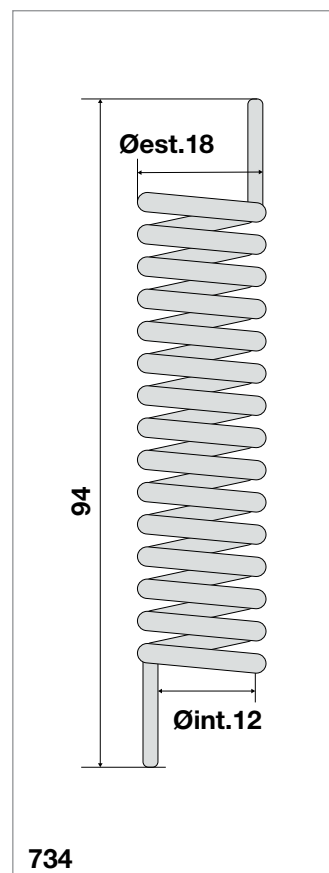
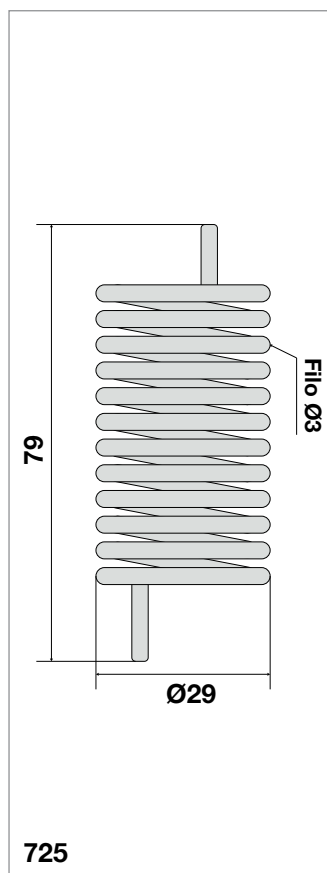
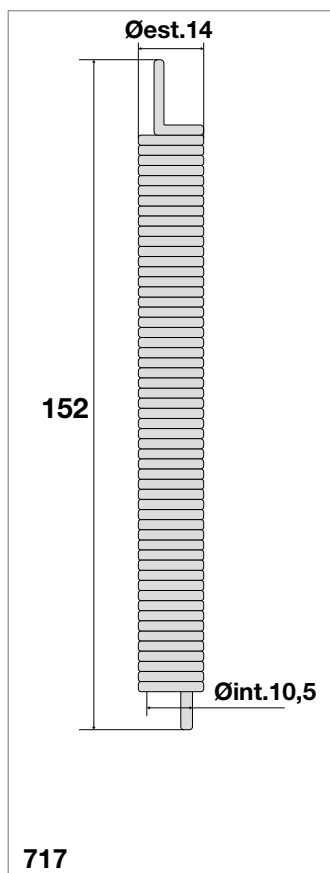
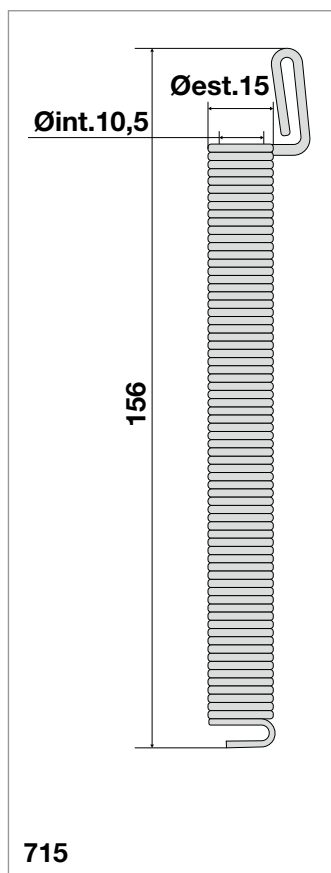
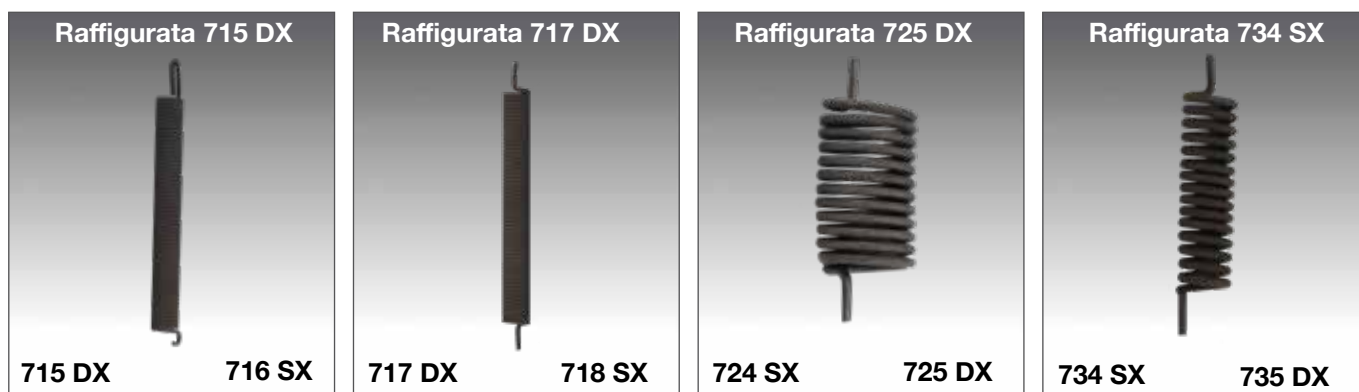

Codice / Code	Descrizione
715	Molla SAFOV destra
716	Molla SAFOV sinistra
717	Molla SAFOV destra
718	Molla SAFOV sinistra
724	Molla FIAM sinistra
725	Molla FIAM destra
734	Molla torsione sinistra
735	Molla torsione destra

ATTENZIONE SOLO PER MOLLE A TORSIONE CONSIDERARE CHE LE MOLLE DESTRE SONO PER PORTE CON CERNIERA A SINISTRA VISTE DAL PIANEROTTOLO, E LE SINISTRE PER PORTE CON CERNIERE A DESTRA VISTE DAL PIANEROTTOLO.

MOLLE PORTE A BATTENTE DI PIANO A TORSIONE TORSION SPRINGS FOR LANDING DOORS

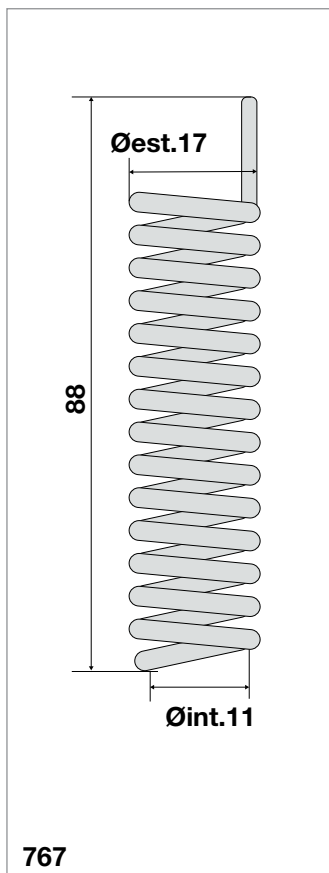
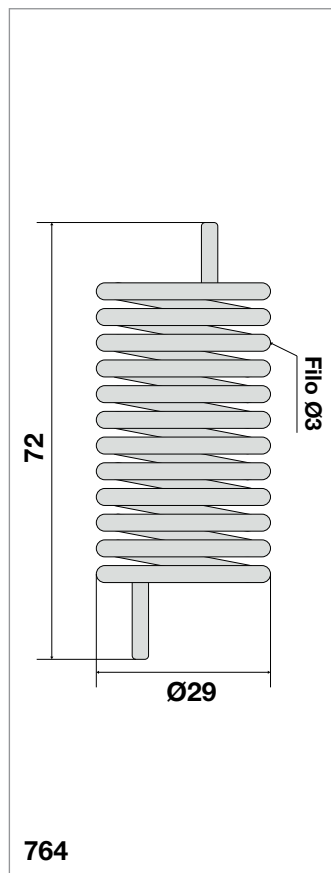
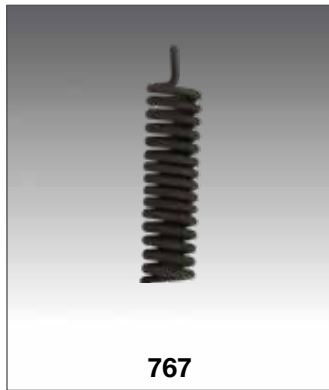
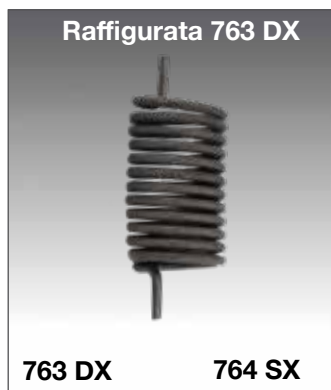

Codice / Code	Descrizione
763	Molla porta piano FIAM DM501 destra
764	Molla porta piano FIAM DM501 sinistra
767	Molla a torsione

MOLLE PORTE A BATTENTE DI PIANO A LAME BLADE SPRINGS FOR LANDING DOORS

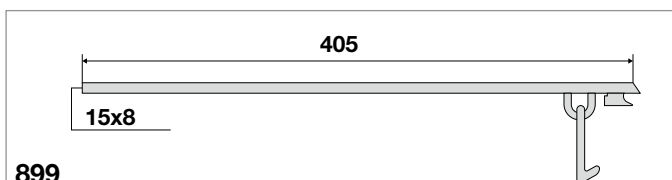
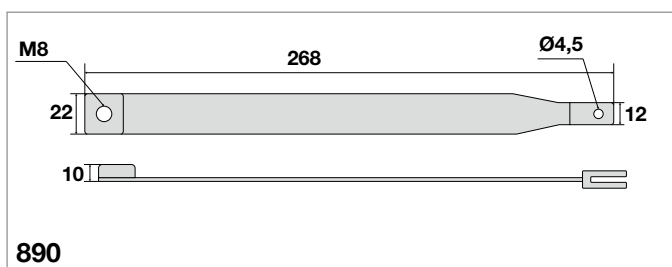
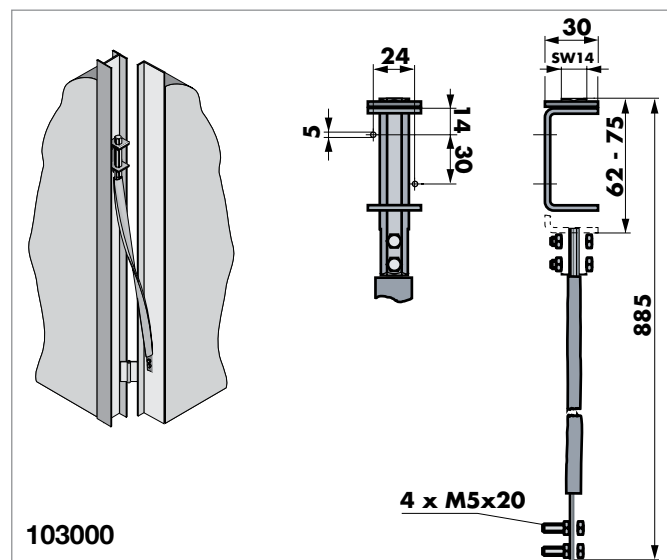
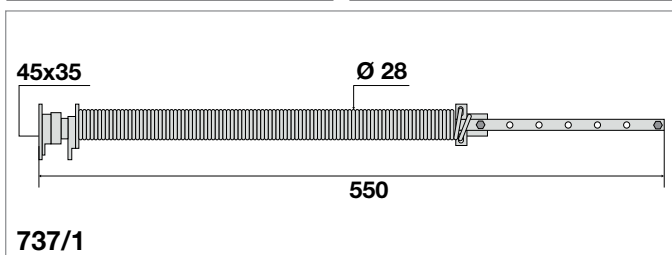
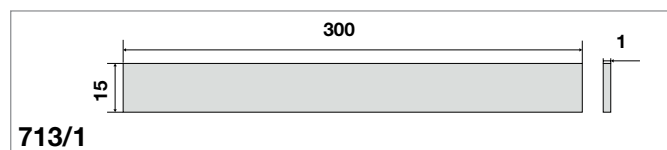
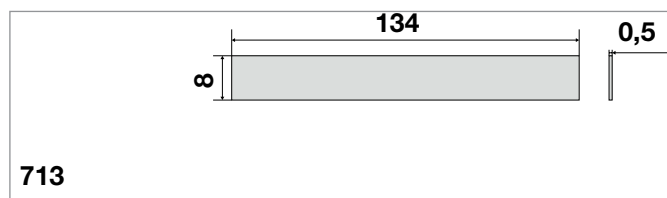
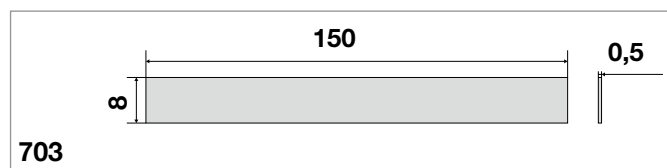
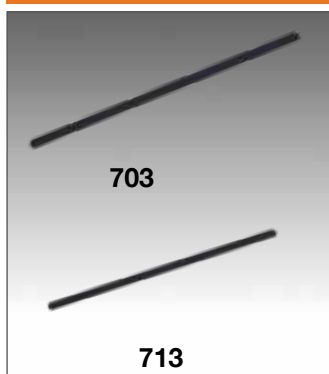

Codice / Code	Descrizione
703	Molla a lamella 150 x 8 x 0,5 mm
713	Molla a lamella 134 x 8 x 0,5 mm
713/1	Molla a lamella per porte BASSETTI
737/1	Dispositivo di richiamo porta di piano SCHINDLER
890	Bandella di richiamo tiramolla in plastica per porta di piano SCHINDLER
899	Attrezzo tiramolla FIAM (per molla codice 704)
103000	Pacco di molle torsione lamellari per porte Canossa

MOLLE PER PORTINE DI CABINA SPRINGS FOR CABIN DOOR

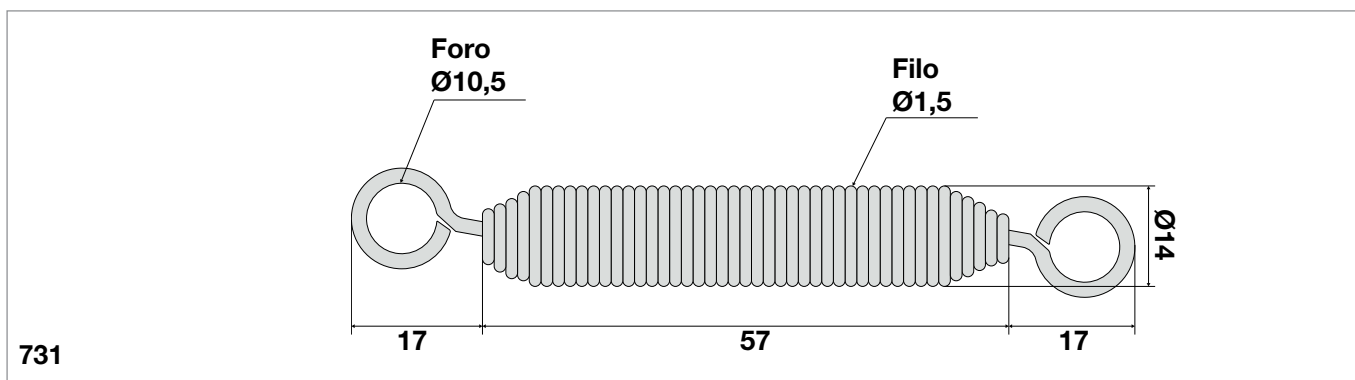
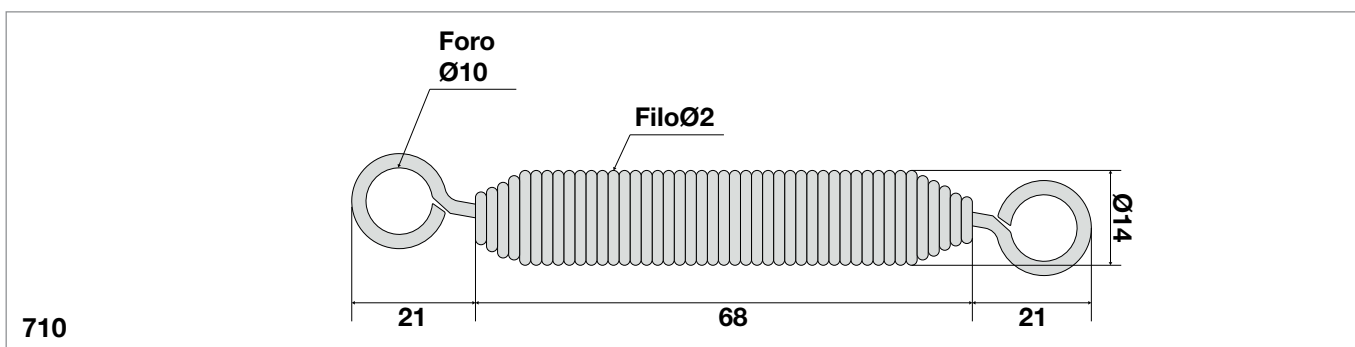
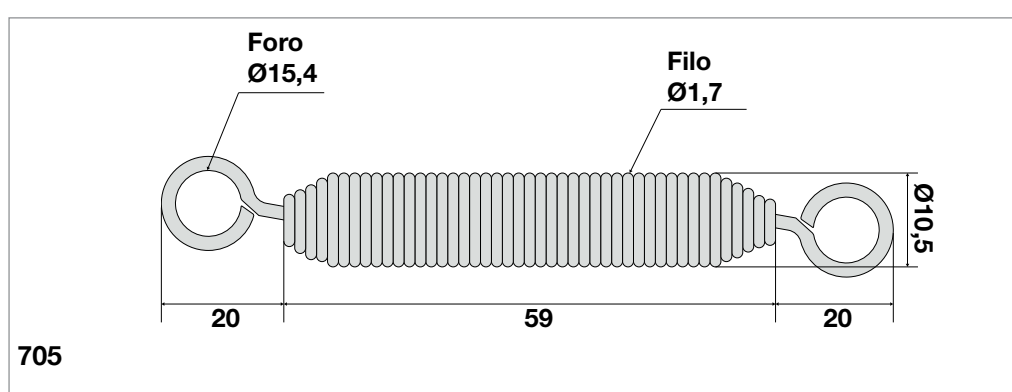
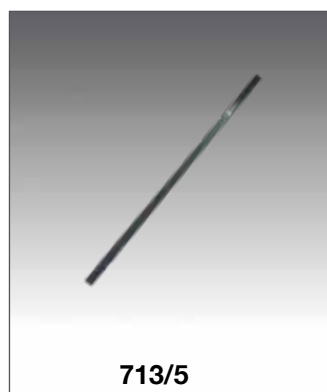

Codice / Code	Descrizione
705	Molla portine cabina FIAM
710	Molla portine cabina standard
713/5	Molla a pacco L=380 mm Larg.10 mm - Sp.0,5 mm
713/6	Molla a torsione pacco lamelle tipo Insubria Atlas
731	Molla portine cabina BASSETTI

MOLLE SOSPENSIONI HANGING SPRINGS

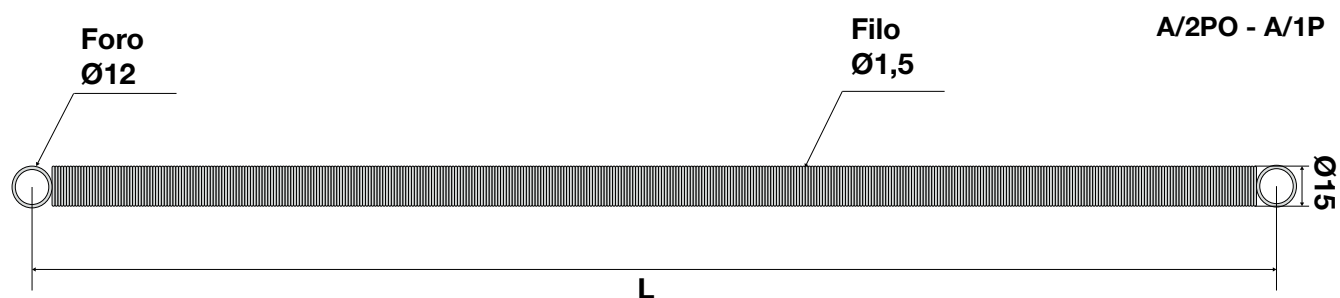
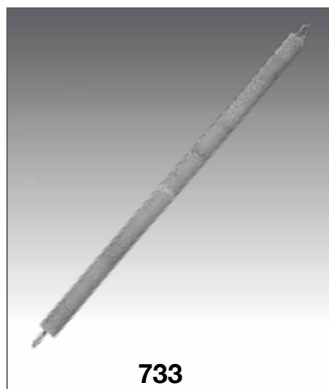

732-732/1

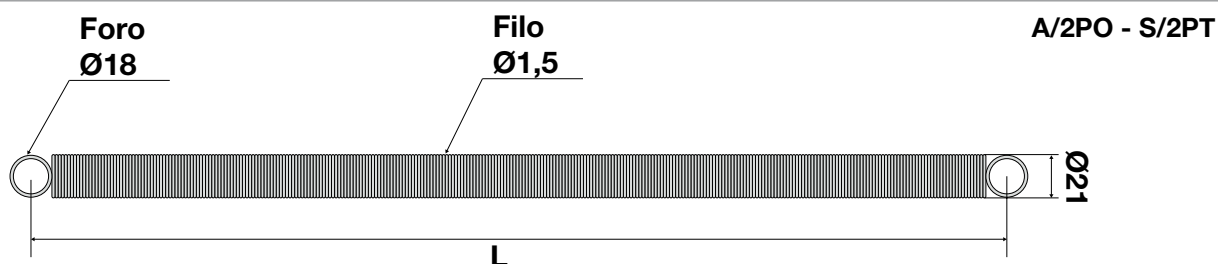

Dal 733 al 733/9

Codice / Code	Descrizione	L. Molla
732	Molla di richiamo porte sospensione A/2PO FIAM larghezza porta 550-750	480
732/1	Molla di richiamo porte sospensione A/1P FIAM larghezza porta 600-950	560
733	Molla di richiamo porte sospensione S/2PO FIAM larghezza porta 500	480
733/1	Molla di richiamo porte sospensione S/2PO FIAM larghezza porta 600 - 650	530
733/2	Molla di richiamo porte sospensione S/2PO FIAM larghezza porta 700 - 750	630
733/3	Molla di richiamo porte sospensione S/2PO FIAM larghezza porta 800 - 850	730
733/4	Molla di richiamo porte sospensione S/2PO FIAM larghezza porta 900 - 950	820
733/5	Molla di richiamo porte sospensione S/2PO FIAM larghezza porta 1000 - 1050	910
733/6	Molla di richiamo porte sospensione S/2PO FIAM larghezza porta 1100 - 1150	1000
733/7	Molla di richiamo porte sospensione S/2PO FIAM larghezza porta 1200 - 1250	1100
733/8	Molla di richiamo porte sospensione S/2PO FIAM larghezza porta 1300 - 1350	1150
733/9	Molla di richiamo porte sospensione S/2PO FIAM larghezza porta 1400 - 1450	1300

MOLLE SOSPENSIONI HANGING SPRINGS

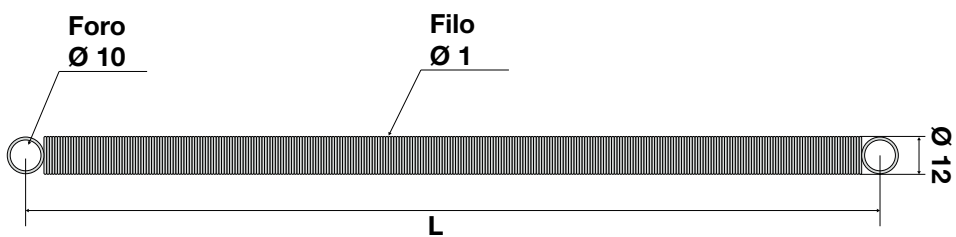

733X

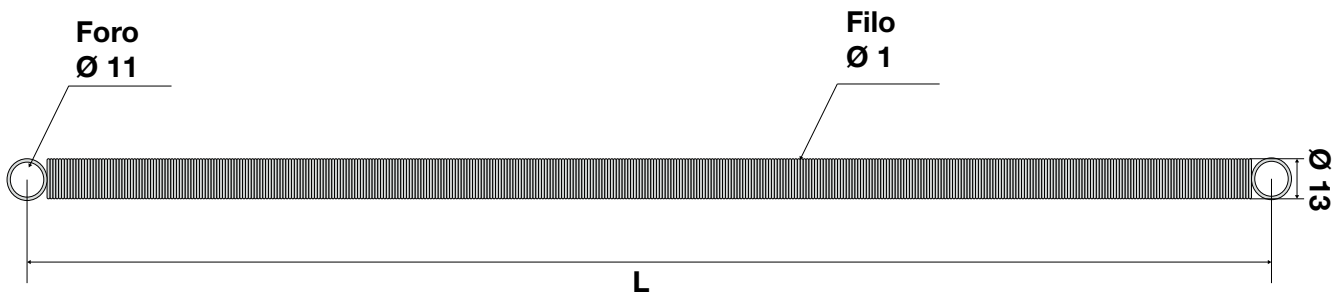

765

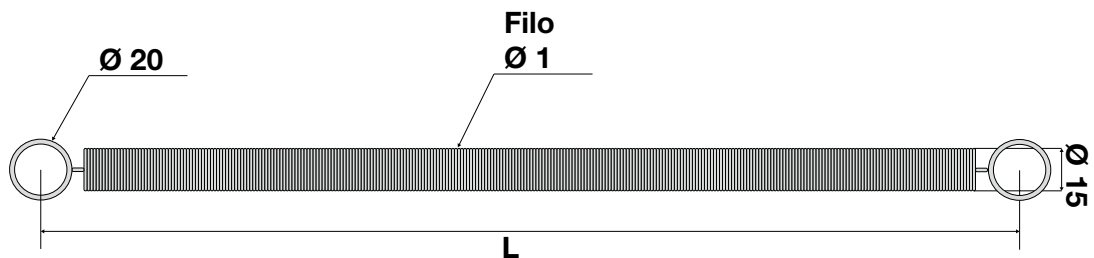

766

Codice / Code	Descrizione	L. Molla
733X	Molla di richiamo porte sospensioni FRALLI 550 - 750	265
765	Molla richiamo sospensioni trazione Ø 13 mm. spira 1 mm	540
766	Molla richiamo sospensioni trazione Ø 15 mm. spira 1 mm	475

MOLLE SOSPENSIONI HANGING SPRINGS

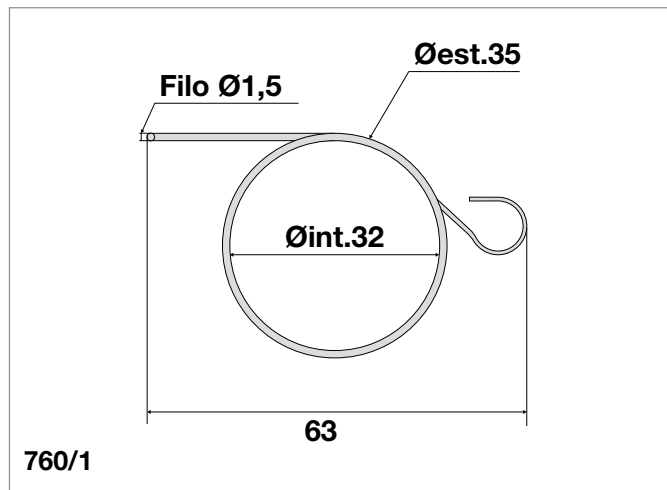
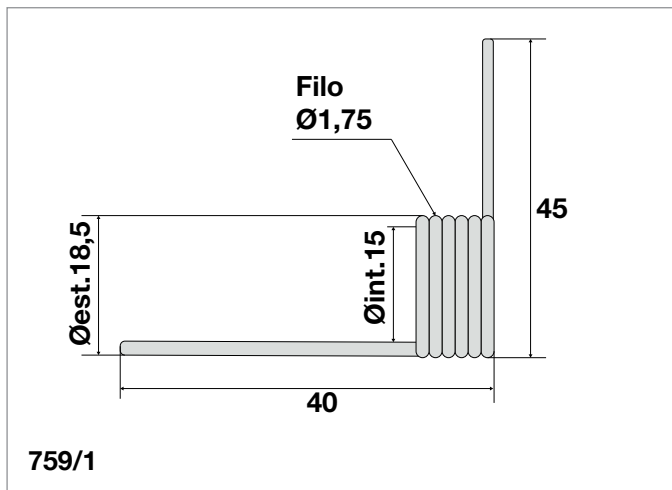
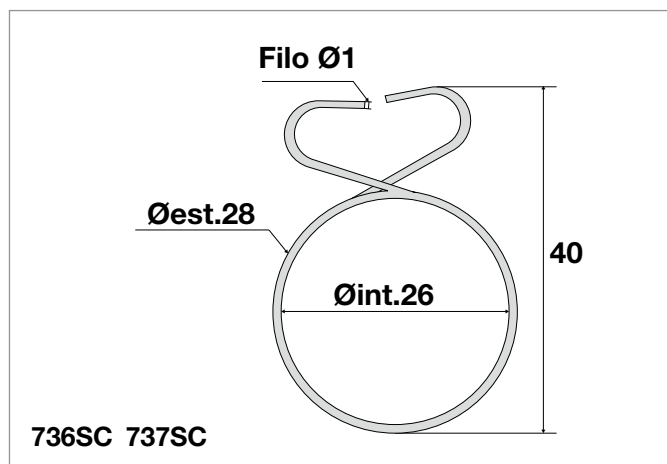
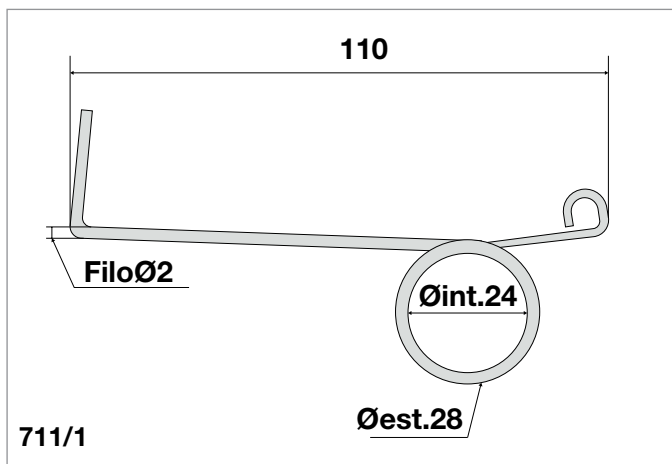
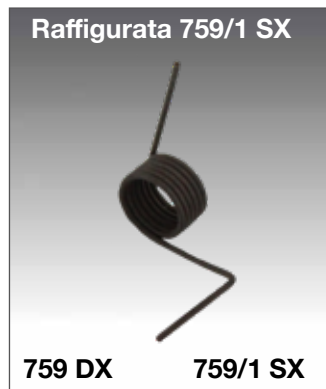

8

Codice / Code	Descrizione
711	Molla per galoppino FIAM tipo S destro
711/1	Molla per galoppino FIAM tipo S sinistro
736SC	Molla serratura porta automatiche SCHINDLER destre
737SC	Molla serratura porta automatiche SCHINDLER sinistre
759	Molla richiamo barra porta catenacci sospensione tipo S FIAM destro
759/1	Molla richiamo barra porta catenacci sospensione tipo S FIAM sinistro
760	Molla per accoppiamento sospensione tipo B FIAM destro
760/1	Molla per accoppiamento sospensione tipo B FIAM sinistro

MOLLE OPERATORE SPRINGS FOR OPERATOR

Raffigurata 726



726

727

Raffigurata 737 SX



736 DX

737 SX



743

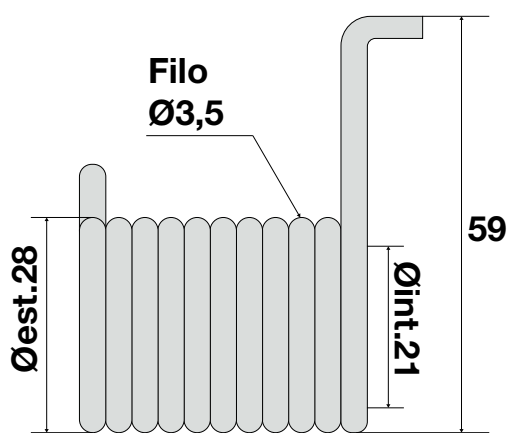

726

727

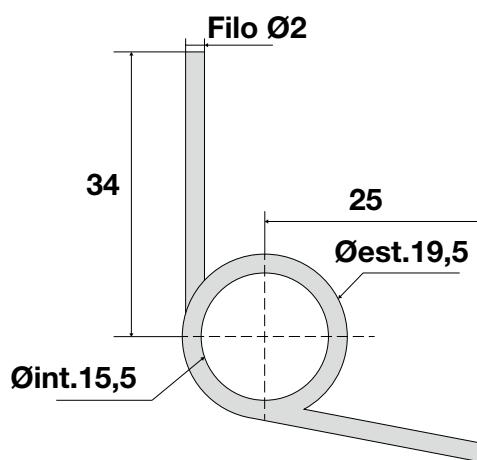

736 DX

737 SX

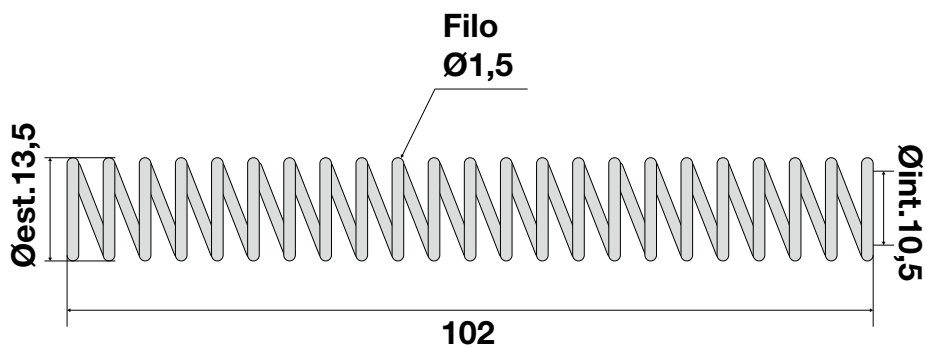

743

Codice / Code	Descrizione
726	Molla per automatismo FIAM sinistra
727	Molla per automatismo FIAM destra
736	Molla per automatismo "S" FIAM destro
737	Molla per automatismo "S" FIAM sinistro
743	Molla puntone di spunto automatismo A-B FIAM

MOLLE OPERATORE SPRINGS FOR OPERATOR

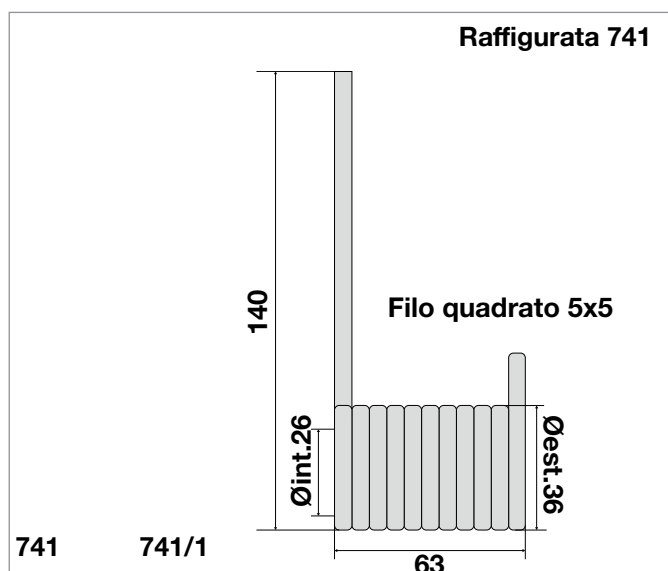
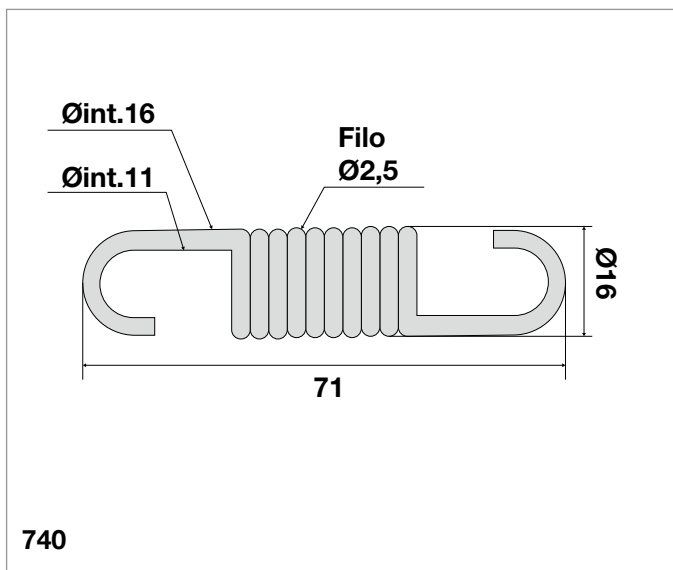
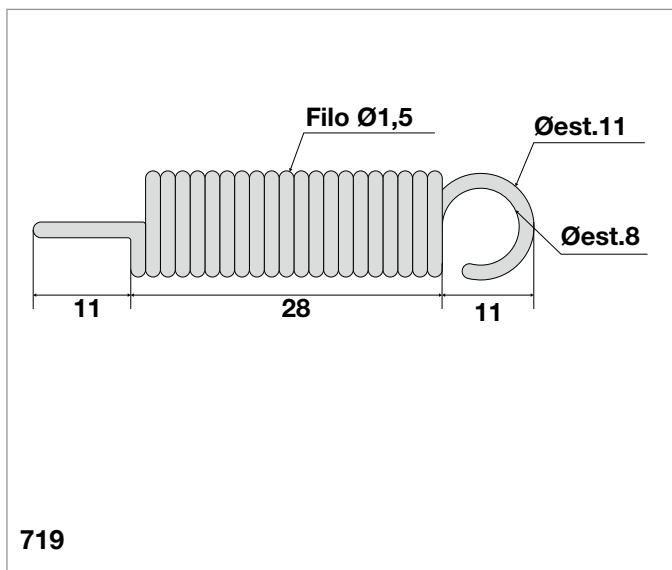
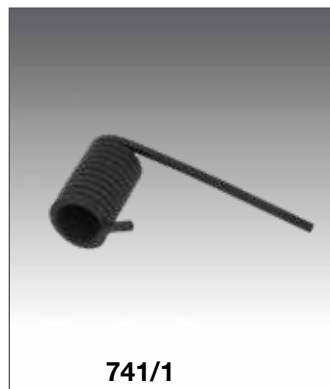

Codice / Code	Descrizione
719	Molla scrocco automatismo FIAM
740	Molla tenditore operatore SCHINDLER
741	Molla QKS 9 destra SCHINDLER
741/1	Molla QKS 9 sinistra SCHINDLER

MOLLE OPERATORE SPRINGS FOR OPERATOR

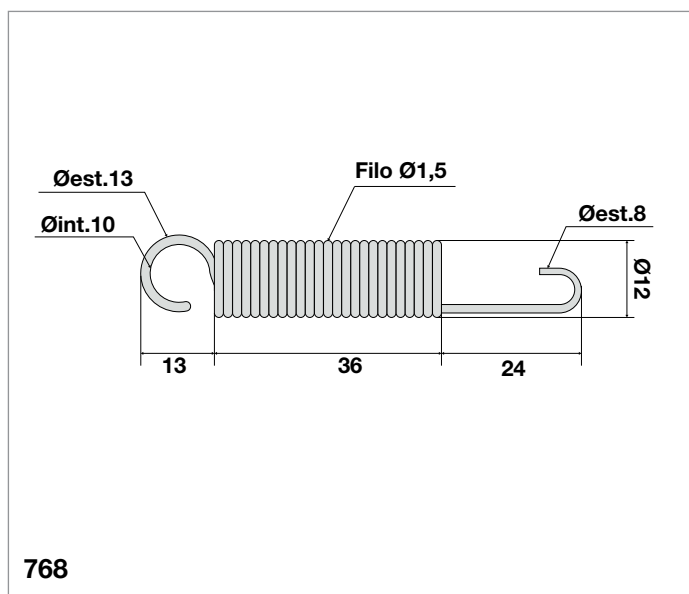
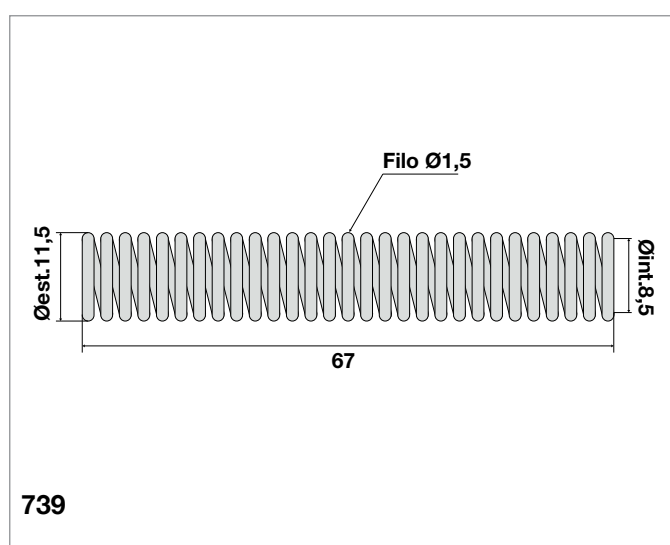
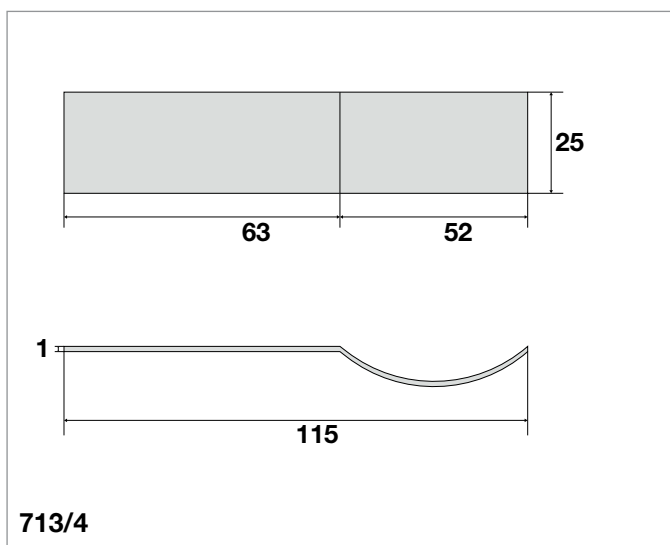
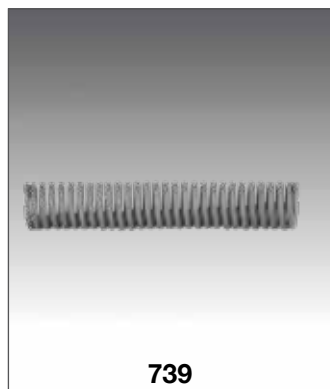
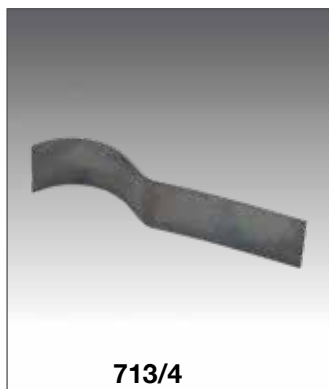

Codice / Code	Descrizione
713/4	Molla balestra per motore operatore BASSETTI
739	Molla per catenacci di blocco SCHINDLER
768	Molla per gancio operatore di cabina SABIEM

MOLLE PER PATTINI RETRATTILI, MOLLE PER PATTINI RETRATTILI CON ELETTRIMAGNETE E ELETTRIMAGNETE PER ARGANO FIAM
SPRINGS FOR RETIRING CAMS WITH ELECTROMAGNETS FOR GEAR FIAM

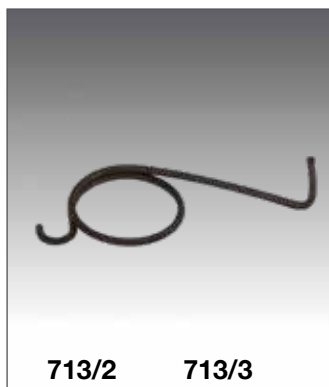

713/2 713/3



738

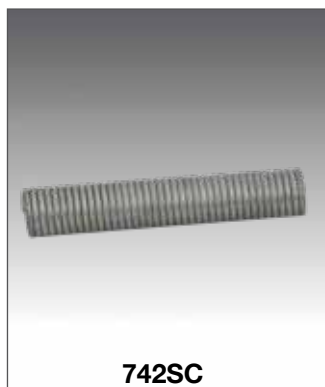

742SC

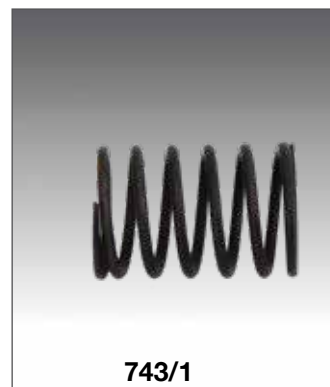

743/1

8

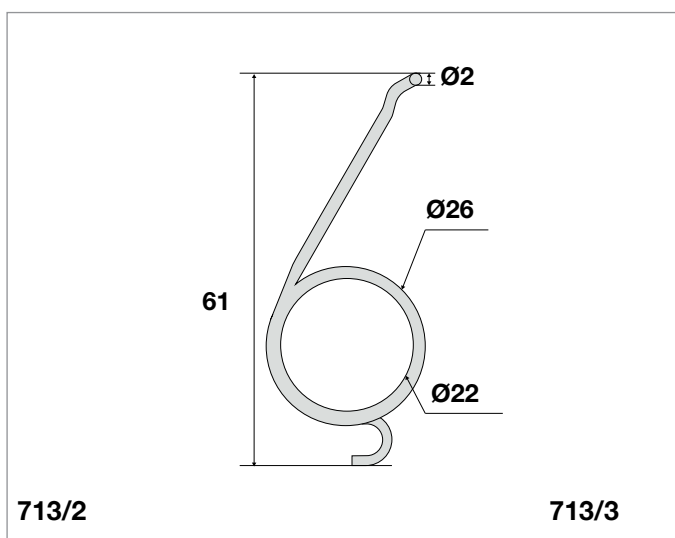

713/2

713/3

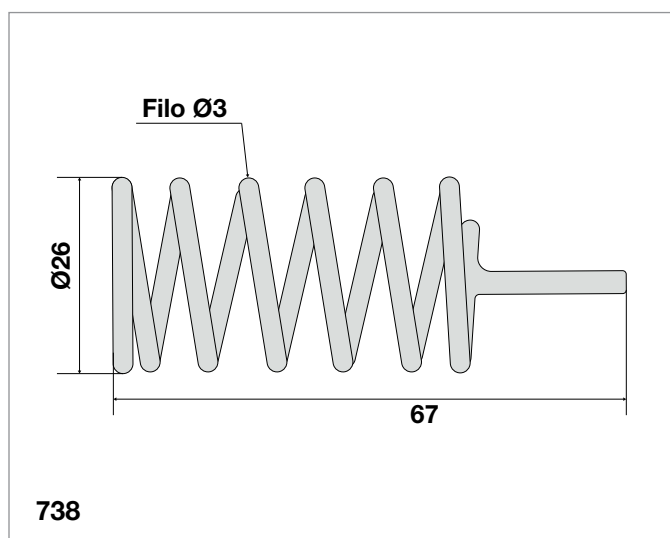

738

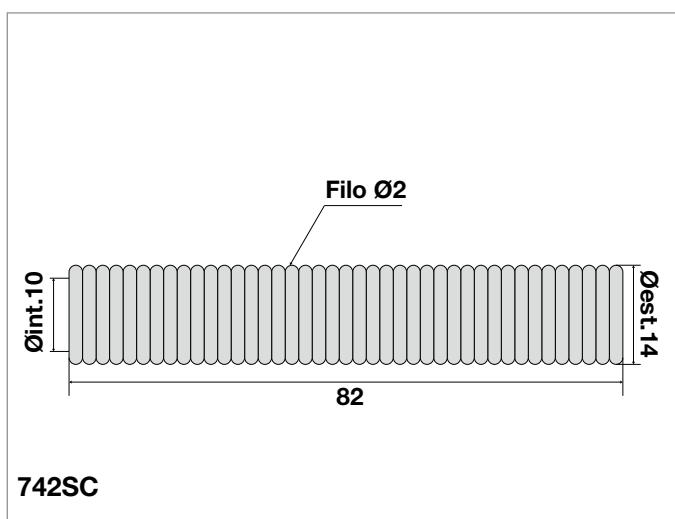

742SC

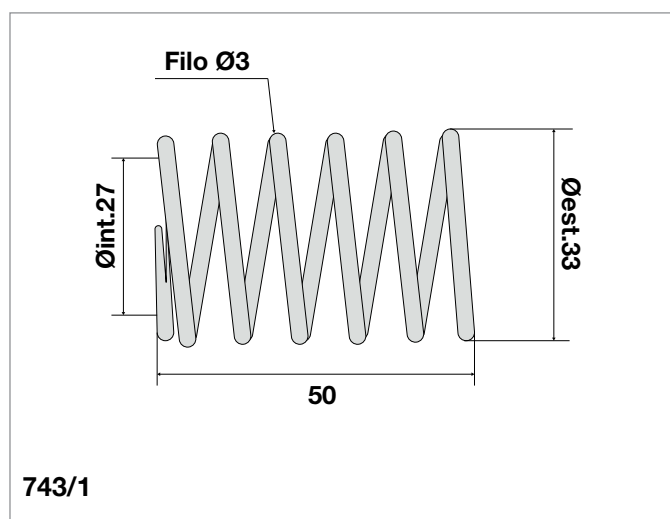

743/1

Codice / Code	Descrizione
713/2	Molla pattino retrattile BASSETTI destra
713/3	Molla pattino retrattile BASSETTI sinistra
742SC	Molla per pattino retrattile SCHINDLER
743/1	Molla a compressione pattino elettromagnetico LG47 FIAM
738	Molla sostegno elettromagnete argani 27-3N-5N FIAM

MOLLE PER LIMITATORI DI VELOCITÀ SPRINGS FOR OVER SPEED GOVERNOR

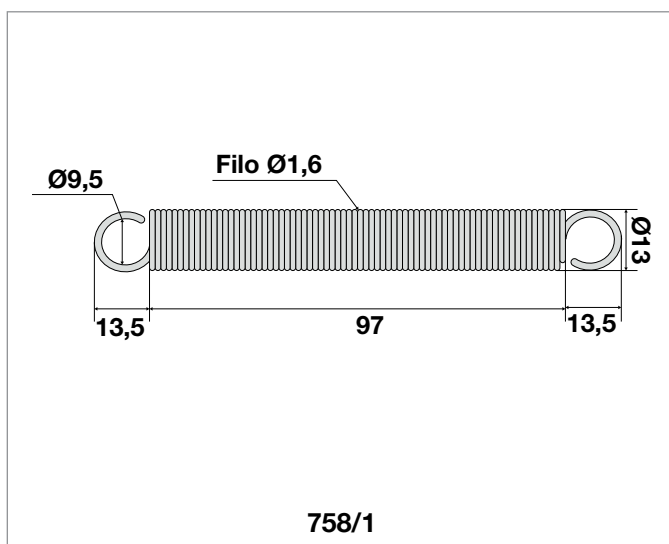
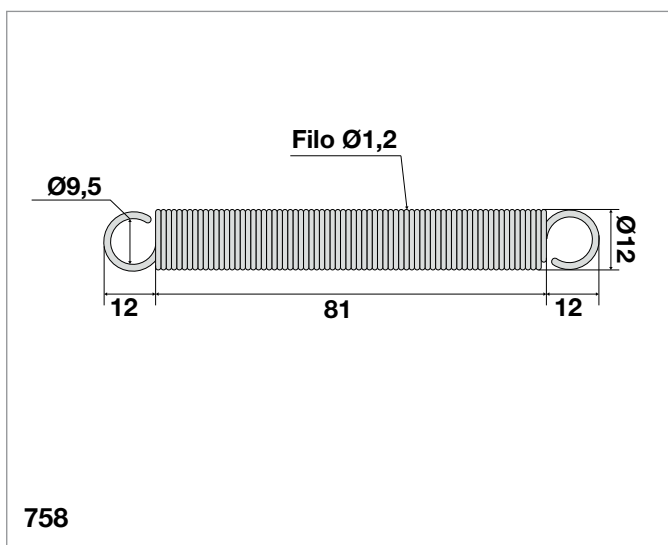
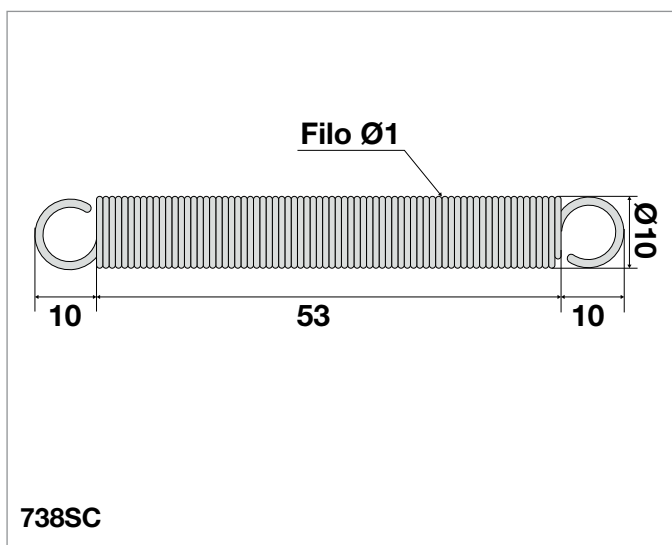
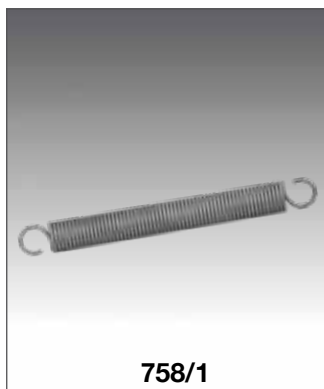
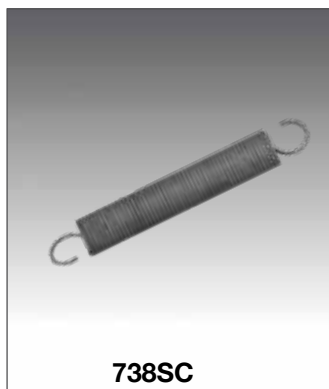

Codice / Code	Descrizione
738SC	Molla per limitatore di velocità SCHINDLER
758	Molla per limitatore di velocità tipo FIAM velocità minore a 1,01 m/s
758/1	Molla per limitatore di velocità tipo FIAM velocità maggiore a 1 m/s

MOLLE PER SELETTORE SCHINDLER, SERRATURA HE2, VALVOLA CENTRALINA IDRAULICA FIAM, MOLLE PER PATTINO ARCATA FIAM BL/BLP, MOLLE PER NUCLEO TELERUTTORE NF41.
SPRINGS FOR SELECTOR SWITCHING SCHINDLER, DOOR LOCK HE2 VALVE SPRING, GUIDE SHOE FIAM BL/BLP, CONTACTOR TRACTION NF41

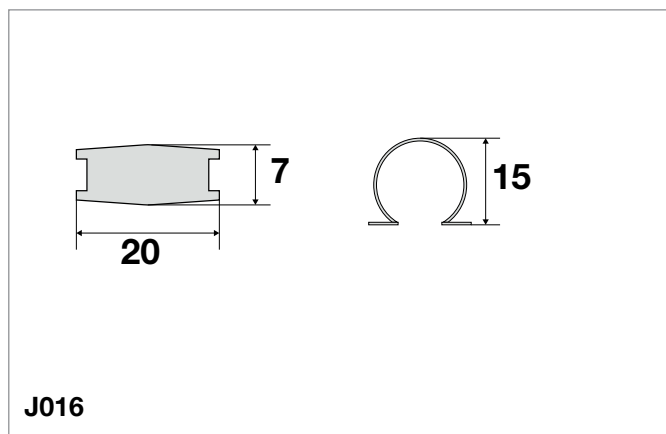
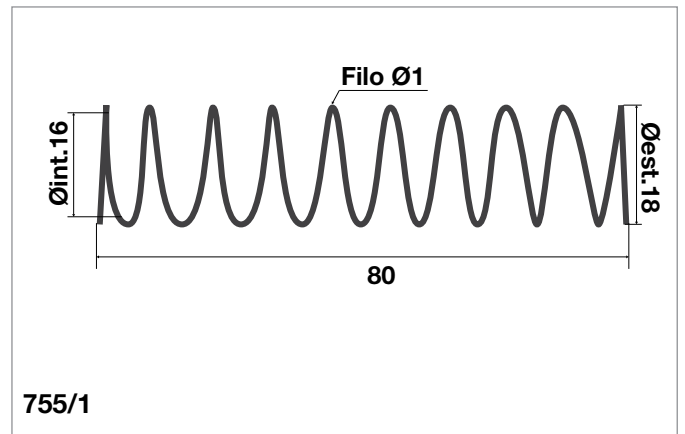
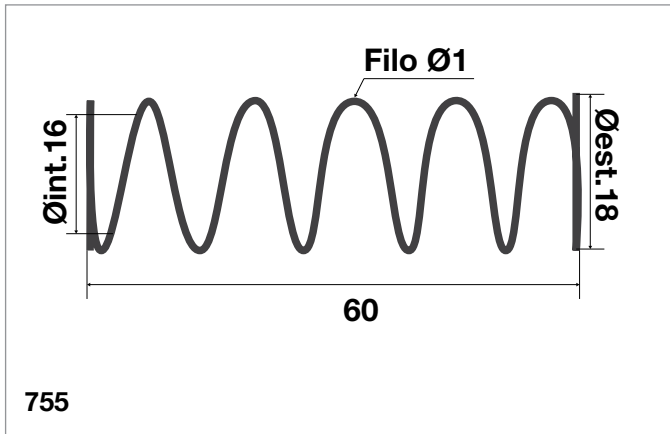
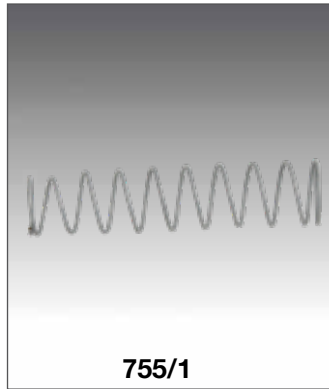
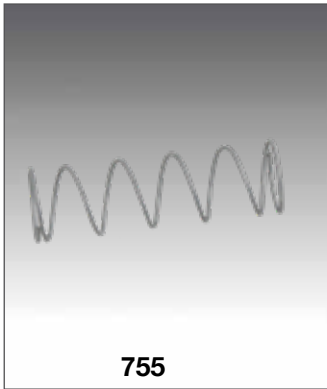

Codice / Code	Descrizione
755	Molla FIAM per valvola salita veloce V3
755/1	Molla FIAM per valvola salita lenta V4
J016	Molla OMEGA martelletto selettore SCHINDLER

MOLLE PER SELETTORE SCHINDLER, SERRATURA HE2, VALVOLA CENTRALINA IDRAULICA FIAM, MOLLE PER PATTINO ARCATA FIAM BL/BLP, MOLLE PER NUCLEO TELERUTTORE NF41.
SPRINGS FOR SELECTOR SWITCHING SCHINDLER, DOOR LOCK HE2 VALVE SPRING, GUIDE SHOE FIAM BL/BLP, CONTACTOR TRACTION NF41

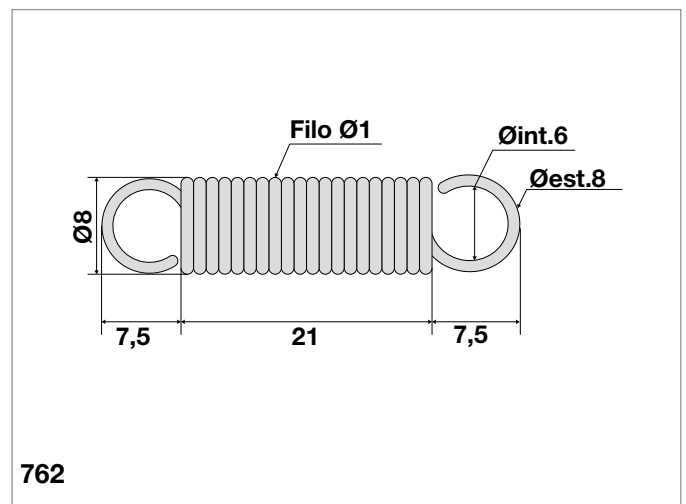
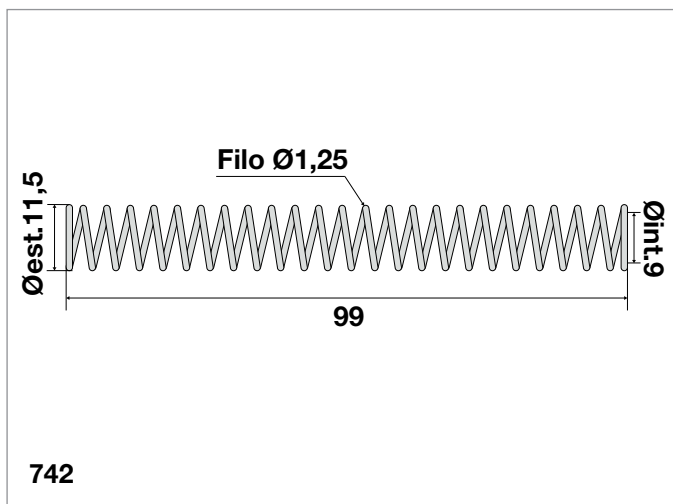
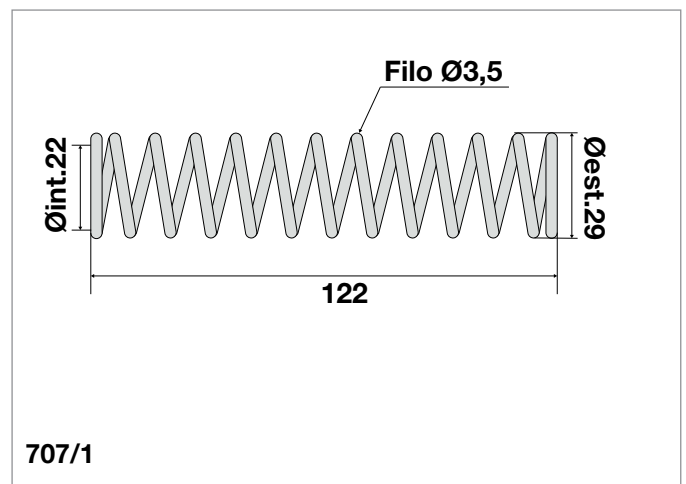
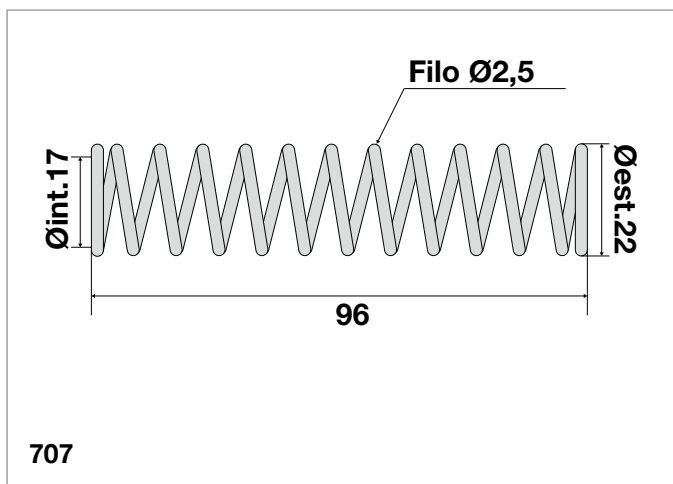
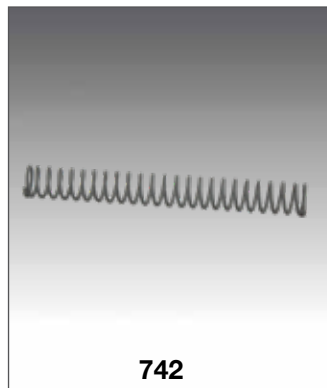
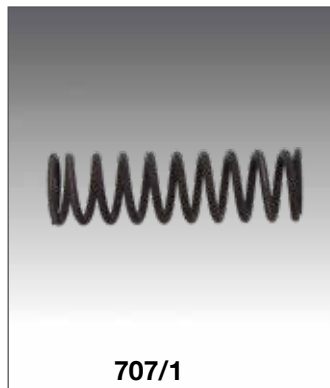
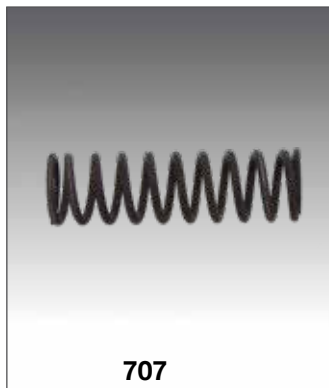

Codice / Code	Descrizione
707	Molla per pattino arcata BL FIAM
707/1	Molla per pattino arcata BLP FIAM
742	Molla ponte catenaccio serratura HE2 SCHINDLER
762	Molla a trazione per nucleo teleruttore "NF41"

MOLLE ATTACCO FUNI ROPE ATTACHMENT ROD SPRINGS

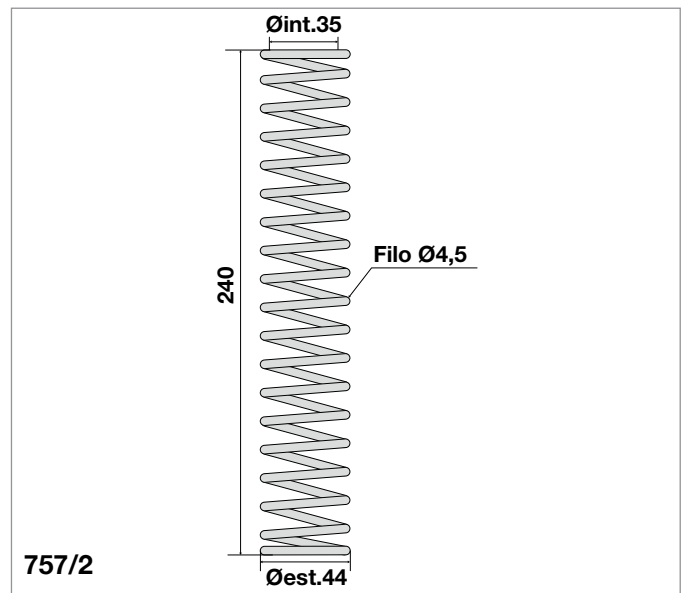
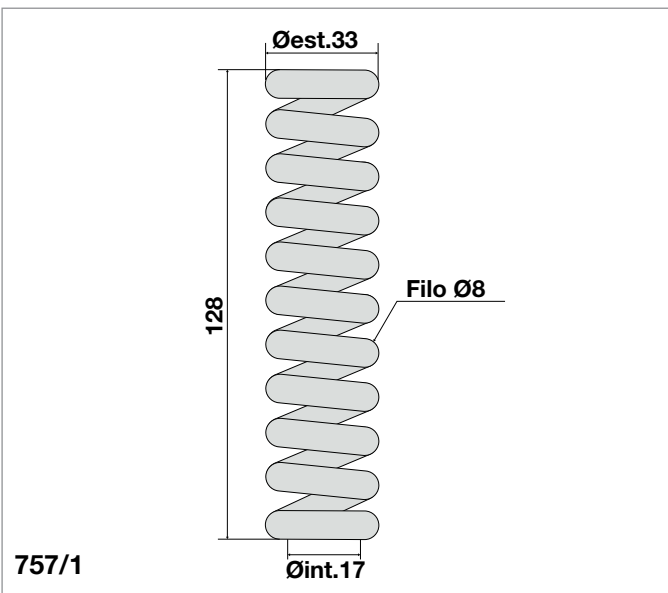
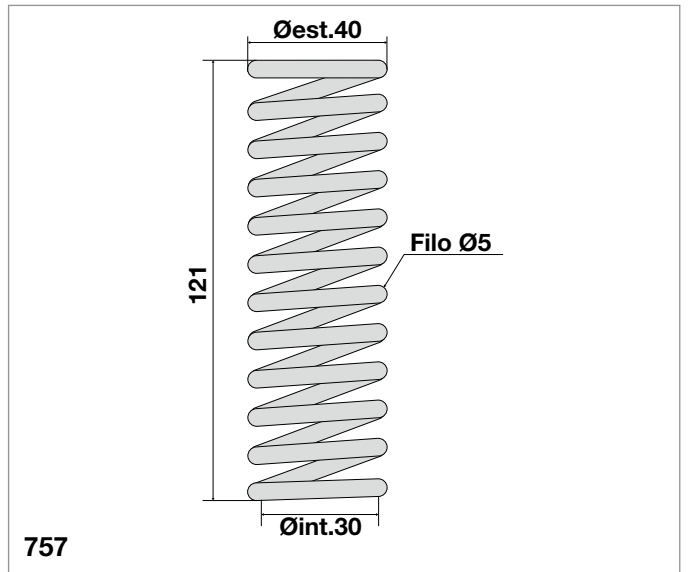
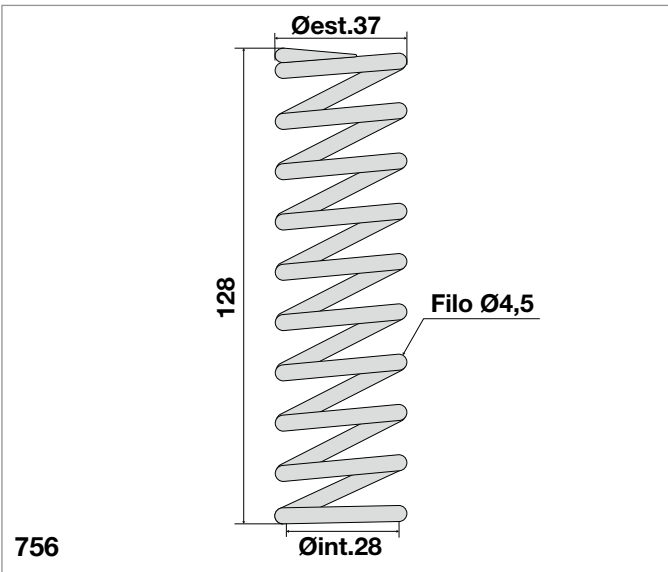
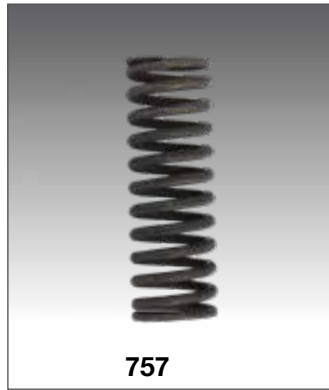

Codice / Code	Descrizione
756	Molla per tirante attacco fune CF2
757	Molla a compressione per tirante
757/1	Molla per tirante fune interna
757/2	Molla per tirante fune esterna

MOLLE TUBOLARI DA INCASSO E SOVRAPPOSIZIONE DICTATOR E16 - E22 CONCEALED AND INVISIBLE JAMB CLOSER FOR MOUNTING IN THE DOOR LEAF DICTATOR E16 - E22

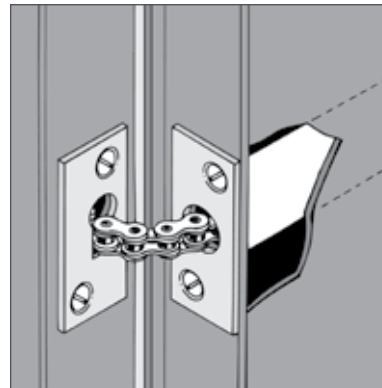
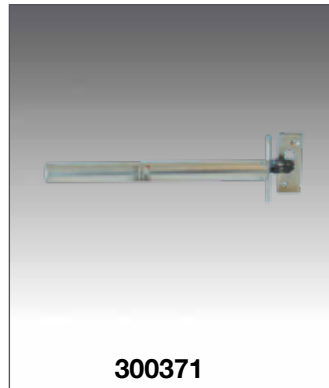

Le molle tubolari DICTATOR sono una soluzione estetica e pratica per la chiusura di porte a battente. Sono disponibili con diametro del tubo da 16 oppure da 22 mm. La distanza è regolabile a seconda della tolleranza tra telaio e battente, in modo da facilitare il montaggio ed ottenere un perfetto pretensionamento della molla. A richiesta l'esecuzione E22 può essere fornita con il tubolare e le piastre frontali in acciaio inox.

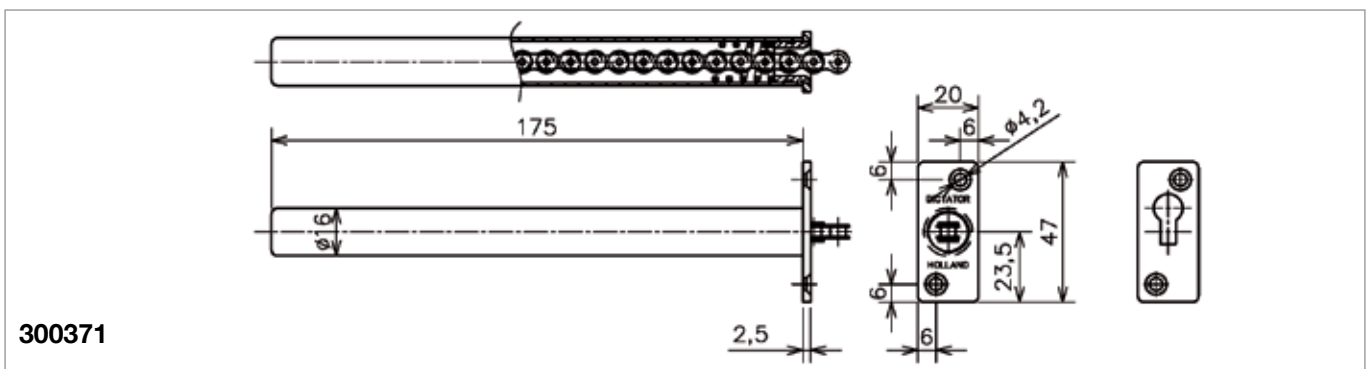
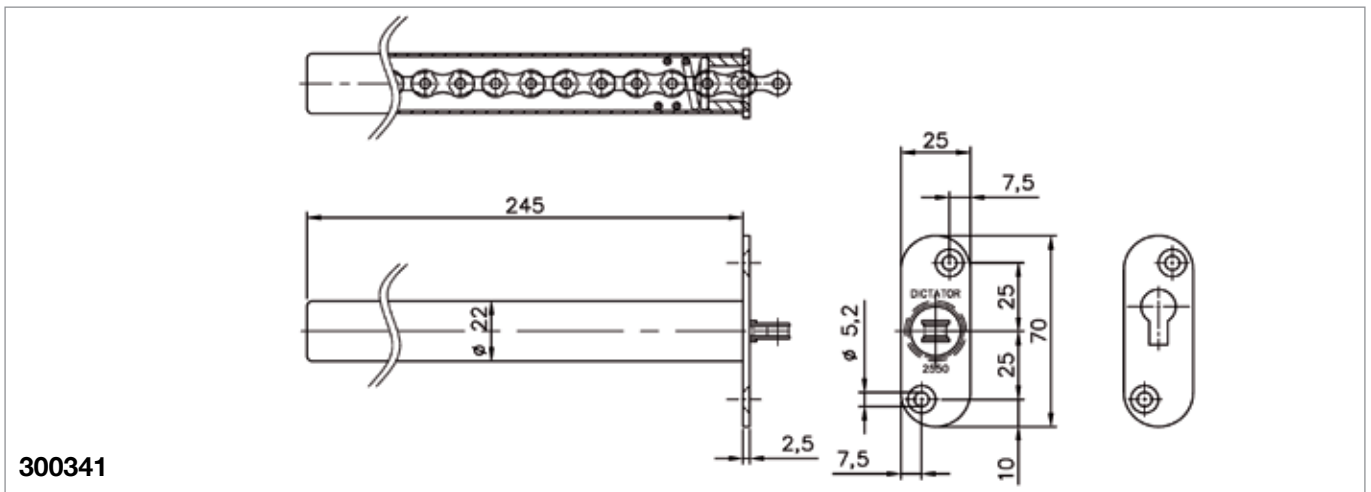

Codice	Tipo	Diametro tubolare	Angola apertura porta	Forza di chiusura (Nm)	Materiale del tubolare	Materiale della piastra
300319	E22/2550 (piastra frontale rotonda) INOX	22	Fino 180°	Da 5 a 30	Alluminio	—
300341	E22/2550 (piastra frontale angolare) Zincato					
300371	E16/2500	16		Da 5 a 15		Acciaio Zincato
300371L	E16/2500 (lunghezza totale 240 mm)					

MOLLE DA SOVRAPPOSIZIONE DICTATOR PICCOLO CLOSING SPRING DICTATOR PICCOLO



Il chiuditore a molla DICTATOR “Piccolo” è stato studiato per porte leggere da interno.

La tensione della molla è regolabile tramite l'asta in dotazione. Si può applicare su porte con battente a filo telaio, oppure con battente sovrapposto al telaio con bulloneria in dotazione.

Può essere fornito in acciaio nichelato o in acciaio inox.

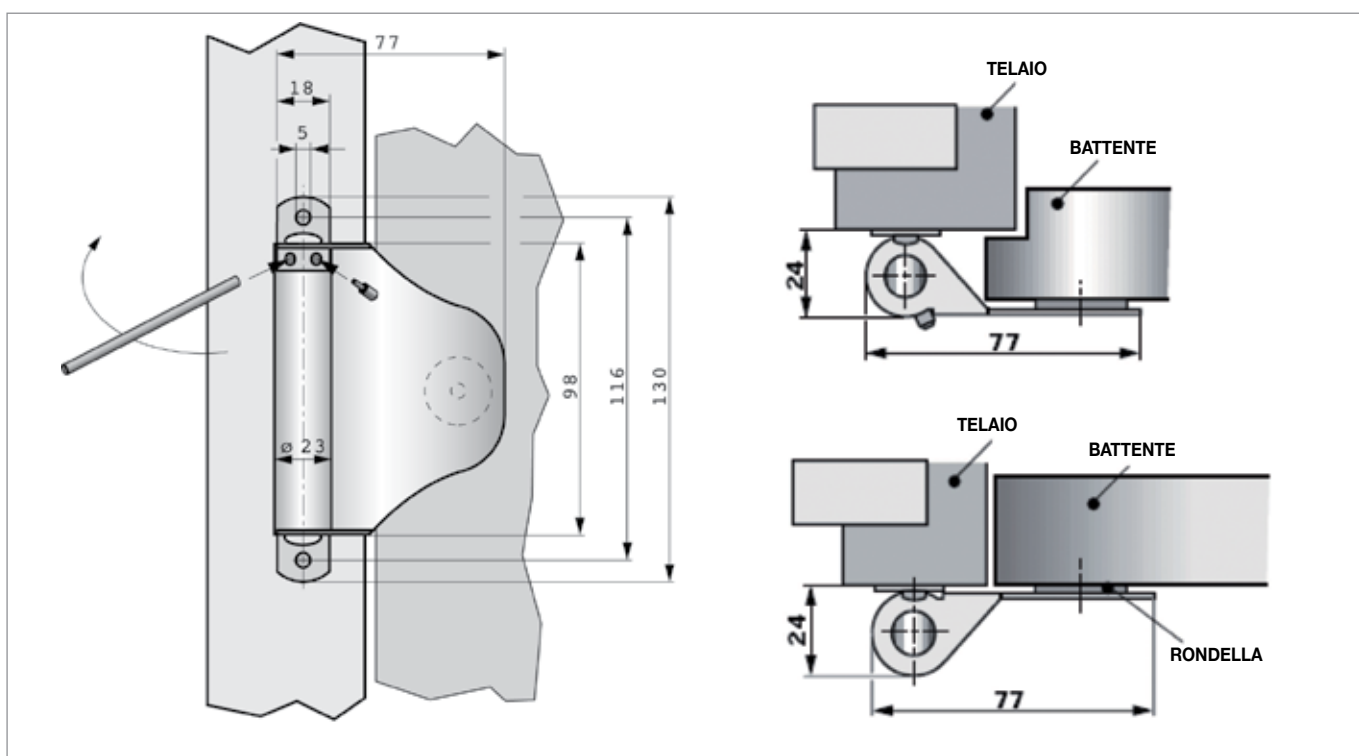

8

Codice	Tipo	Angolo apertura max	Forza di chiusura (N)	Finitura
300339	“Piccolo”	90°	da 10 a 50	Acciaio inox
300340				Acciaio nichelato
300340S				Nero RAL 9005
300340X				Grigio alluminio

MOLLE TUBOLARI DA INCASSO DICTATOR D2A - D4 CLOSING SPRING WITH OPERATING ARM DICTATOR D2A - D4

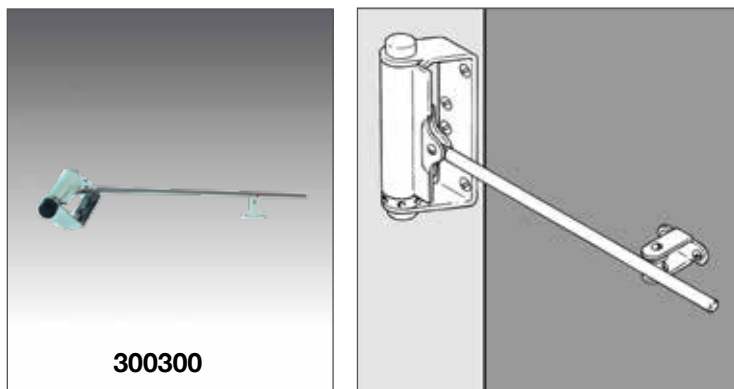

Il chiuditore a molla DICTATOR si distingue per l'accurata esecuzione e per la forza meccanica di chiusura disponibile. Di facile montaggio sovrapposto, la tensione della molla è regolabile.

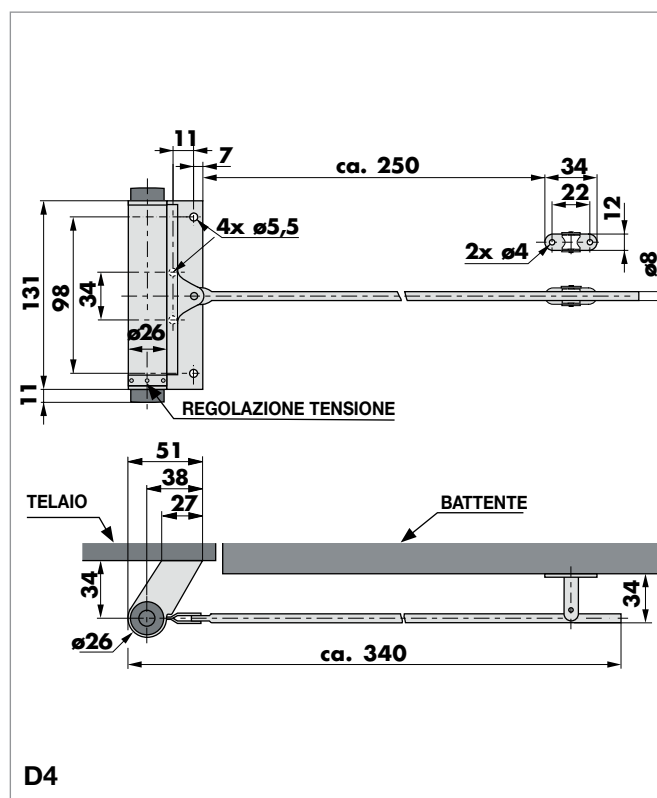
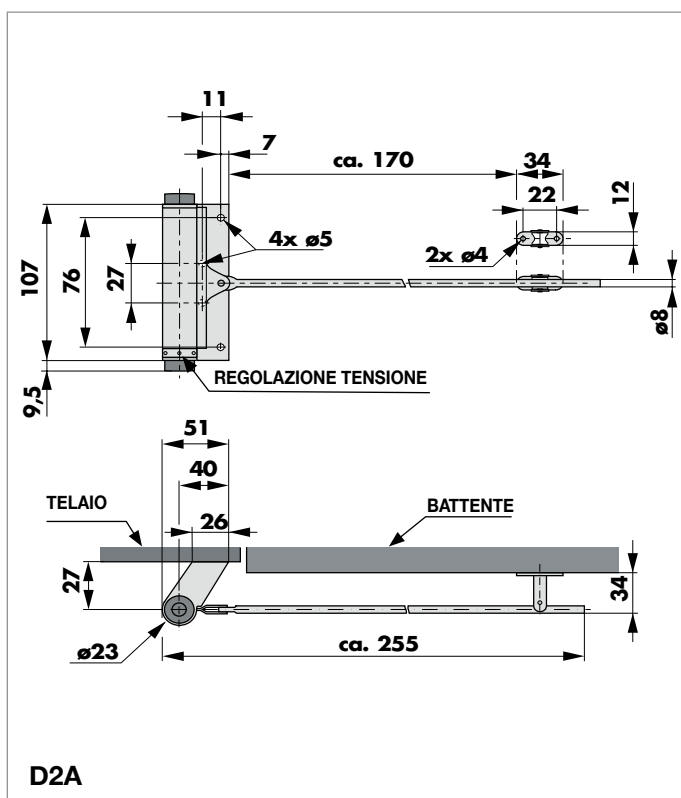

Codice	Tipo	Forza di chiusura (N)	Materiale	Finitura
300300	D2A	da 0 a 10	Acciaio	Nichelato
300308				Acciaio inox
300320	D4	da 10 a 50		Nichelato
300328				Acciaio inox

**PERNO AGGANCIAMENTO MOLLA PORTE SEMIAUTOMATICHE TIPO "DM - 1101"
 PERNO CON SCANALATURA PER TENSIONE MOLLA
 PIVOT HOOK SPRINGS FOR SEMIAUTOMATIC DOOR TYPE "DM - 1101"
 PIVOT WITH GROOVE FOR SPRING TENSION**

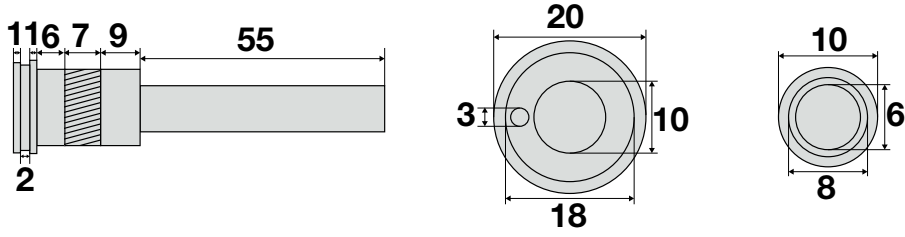

709/1

8

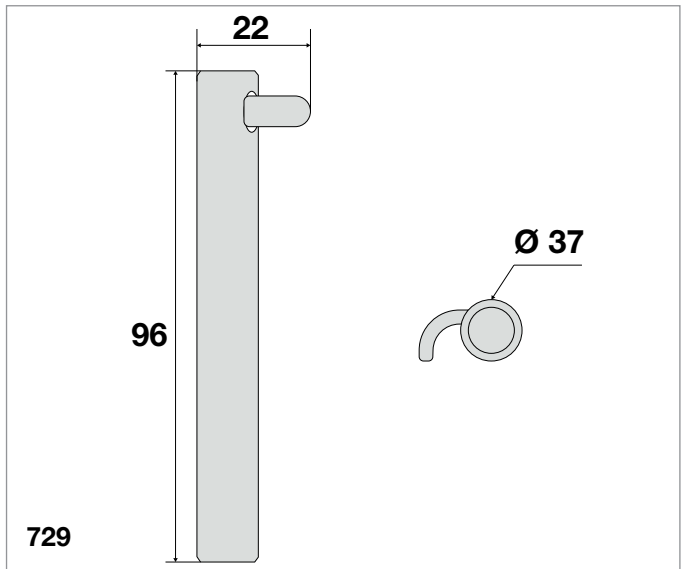
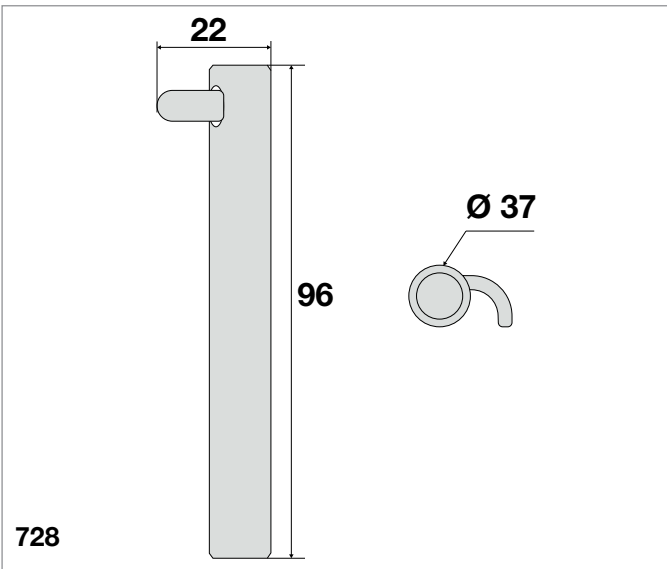

Codice / Code	Descrizione
709/1	Perno superiore con scanalatura per tensione molla cod.708 e cod.709
728	Perno aggancio destro porta FIAM DM.1101
729	Perno aggancio sinistro porta FIAM DM.1101

TAMPONI DI BATTUTA PER PORTE DI PIANO TF - VICINI - BASSETTI
DOOR STOP FOR LANDING DOORS TF - VICINI - BASSETTI

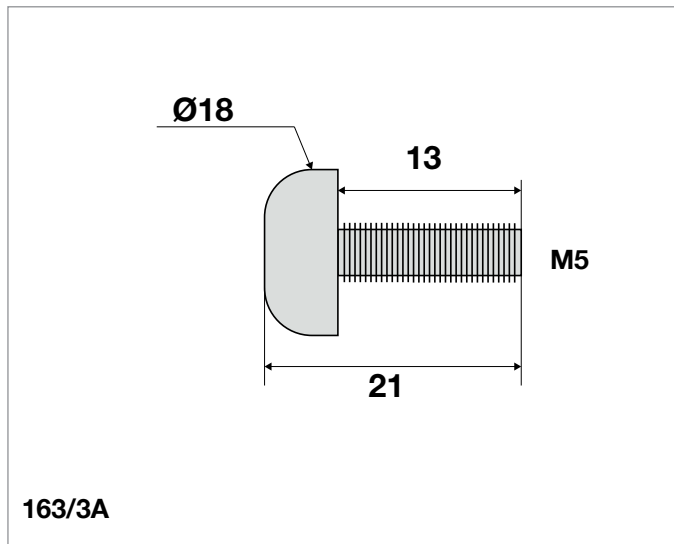
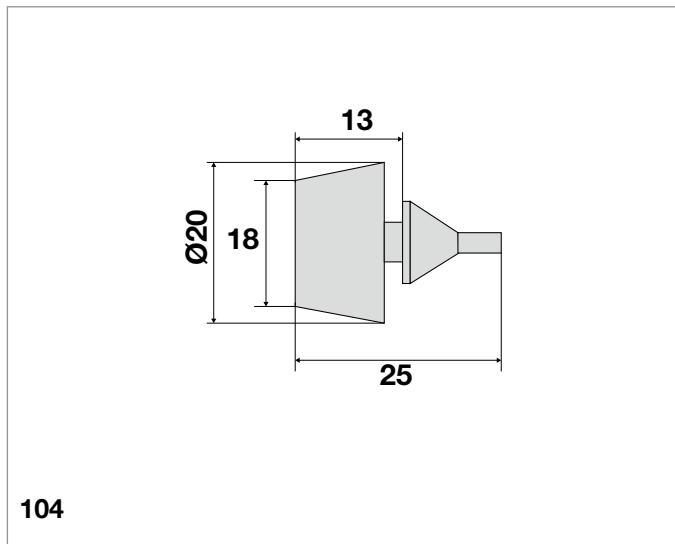
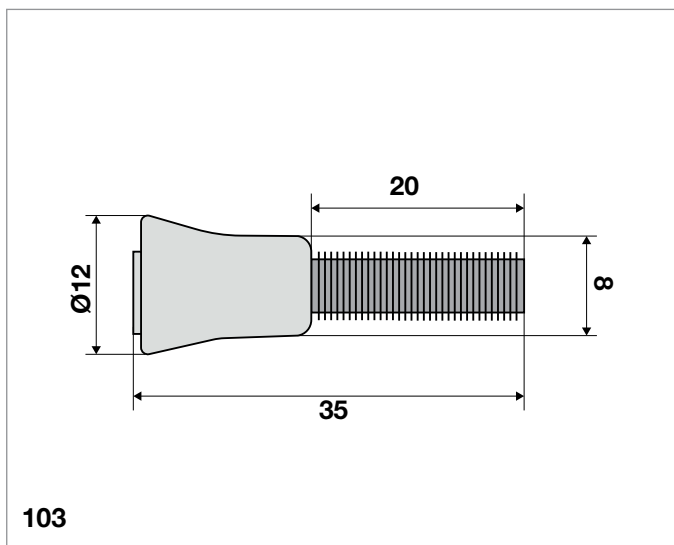
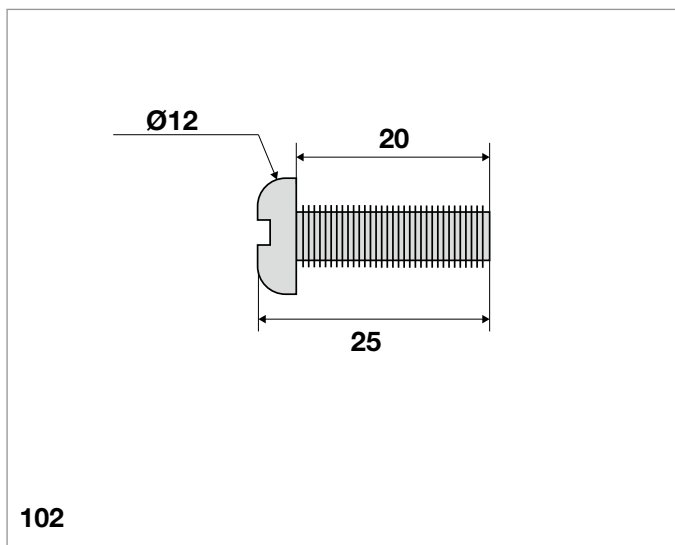
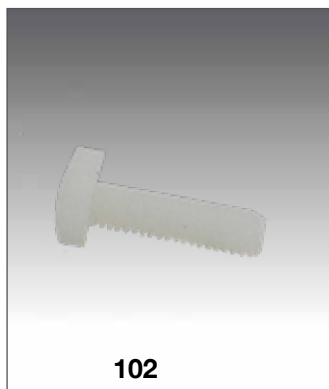

8

Codice / Code	Descrizione
102	Tampone 6x20 con taglio a cacciavite in nylon per porte TF
103	Tampone arresto porte BASSETTI
104	Tampone paracolpi per porta semiautomatica BASSETTI
163/3A	Tampone M5x13 per porta VICINI

FERMI ALTI E BASSI E ATTACCHI MOLLE PER PORTINE DI CABINA
RUBBER DOOR STOP LONG, SHORT AND SPRING CONNECTION FOR
CABIN DOOR

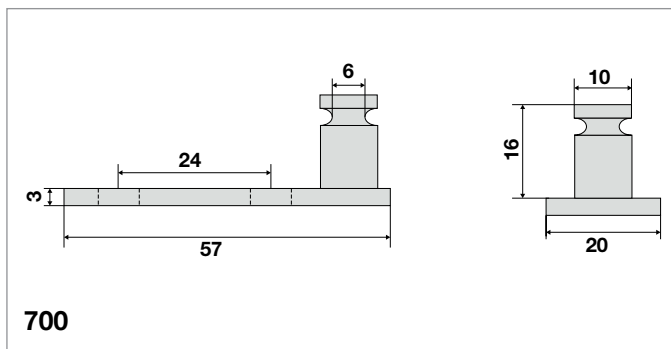
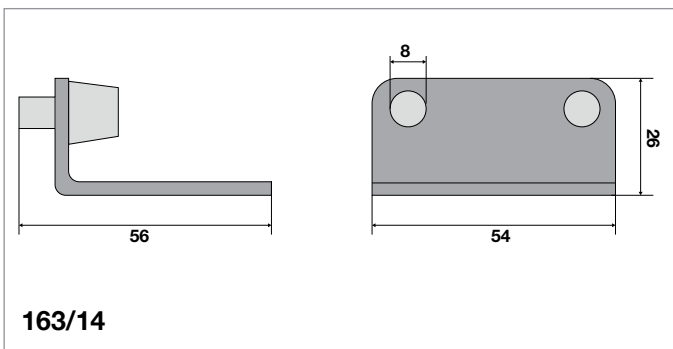
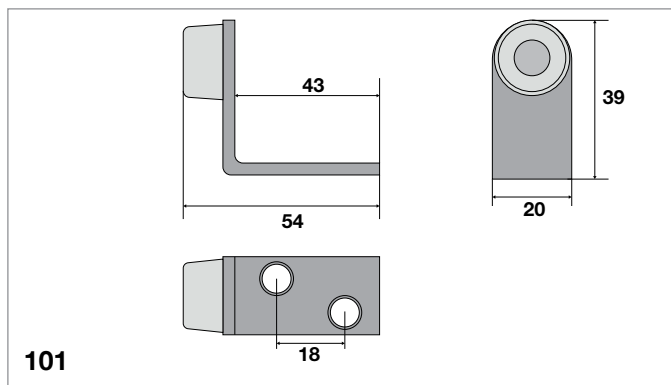
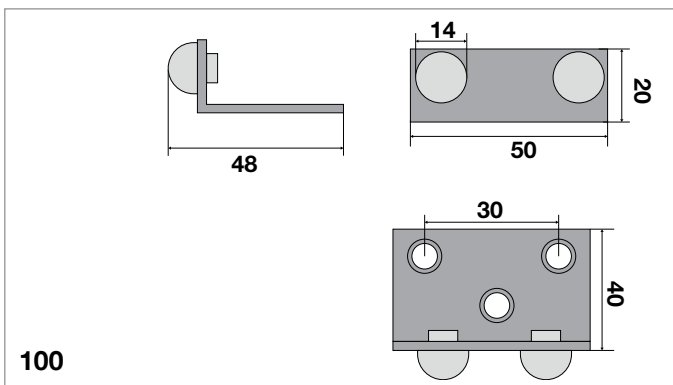
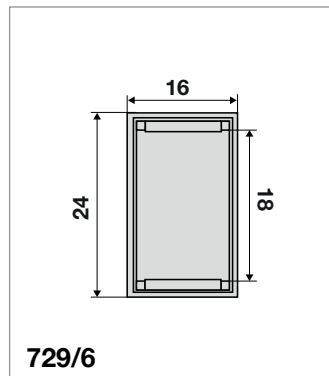
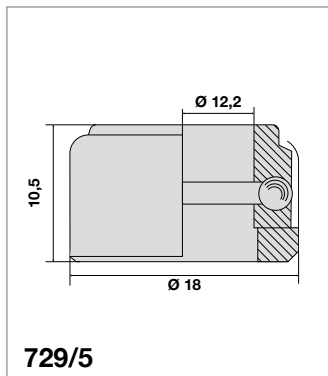

Codice / Code	Descrizione
100	Fermo alto portine cabina
101	Fermo basso portine cabina
163/14	Fermo alto cabina
700	Attacco molle portine
729/5	Cuscinetto reggispinta a sfere per sostegno porte a battente FIAM
729/6	Cuscinetto a rullo porte Kramer

CERNIERE PORTINE CABINA - E PORTA DI PIANO SCHINDLER E BASSETTI HINGES FOR SWING DOOR AND LANDING DOOR SCHINDLER AND BASSETTI

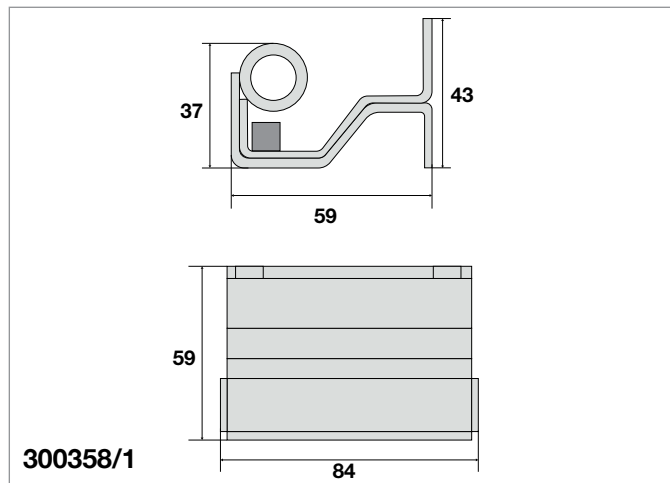
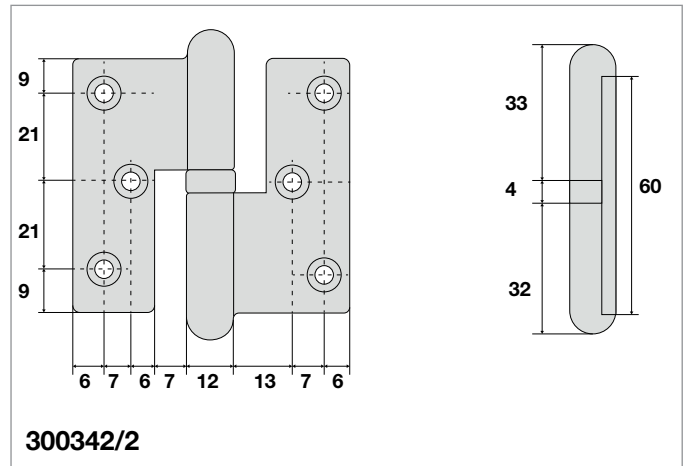
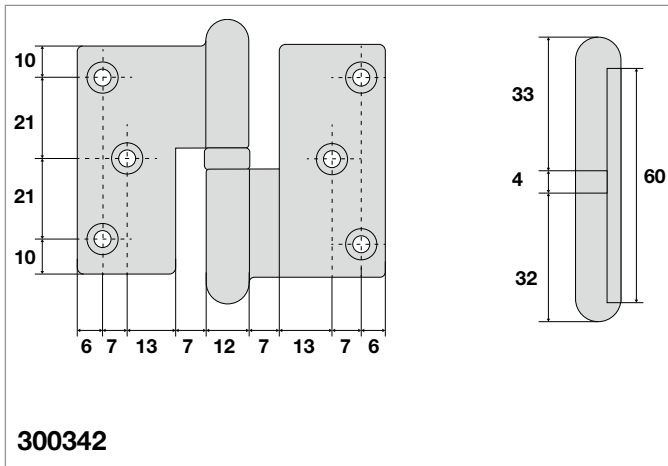

Codice / Code	Descrizione
300342	Cerniera cromata lucido 60x80 DX per ante BASSETTI
300342/1	Cerniera cromata lucido 60x80 SX per ante BASSETTI
300342/2	Cerniera cromata lucido 60x65 DX per ante BASSETTI
300342/3	Cerniera cromata lucido 60x65 SX per ante BASSETTI
300342/4	Cerniera cromata oro 60x80 DX per ante BASSETTI
300342/5	Cerniera cromata oro 60x80 SX per ante BASSETTI
300342/6	Cerniera cromata oro 60x65 DX per ante BASSETTI
300342/7	Cerniera cromata oro 60x65 SX per ante BASSETTI
300358/1	Cerniera per porta a battente di piano SCHINDLER in ferro zincata

CERNIERE A LIBRO PORTINE CABINA HINGES FOR CABIN DOOR

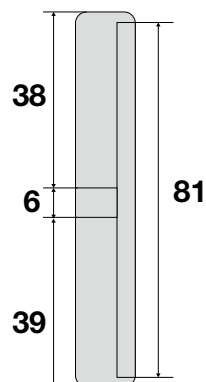
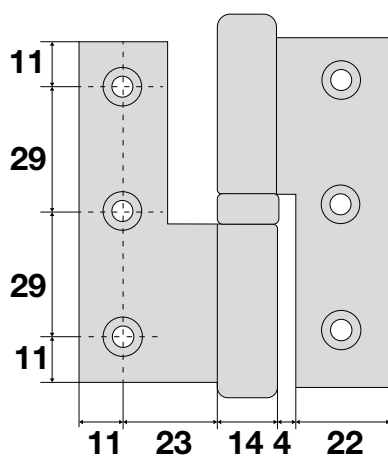

300370 300370/1

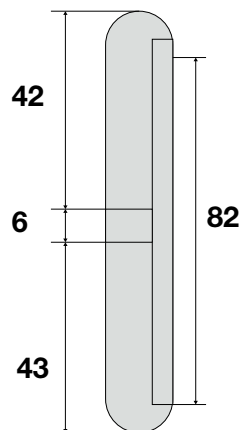
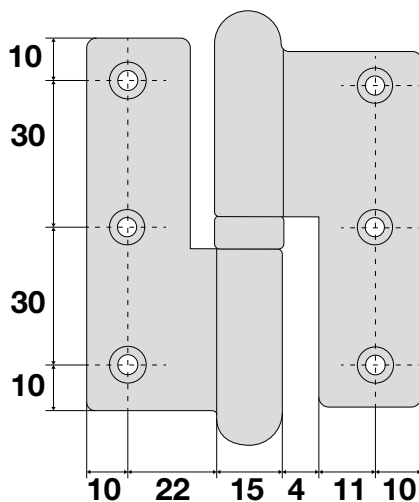

300370/2 300370/3

Codice / Code	Descrizione
300370	Cerniera a libro 80x75 ottone cromato DX
300370/1	Cerniera a libro 80x75 ottone cromato SX
300370/2	Cerniera a libro 80x75 ottone lucido DX
300370/3	Cerniera a libro 80x75 ottone lucido SX

CERNIERE A LIBRO PER PORTINE DI CABINA HINGES FOR CABIN DOOR



300358/3



300358/5



300358/7

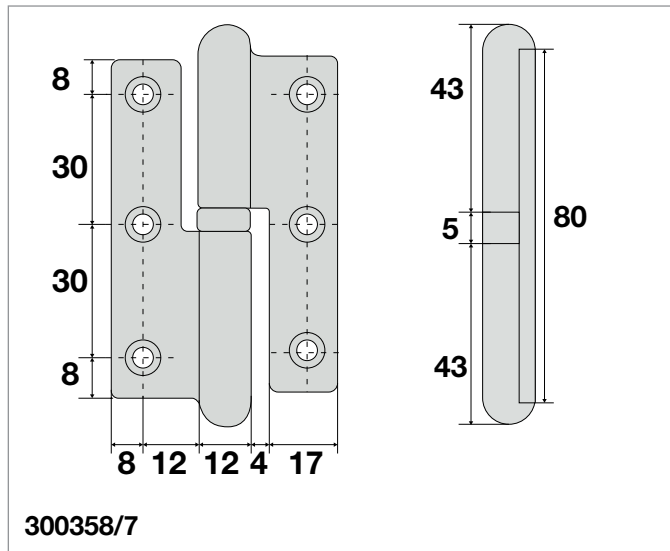
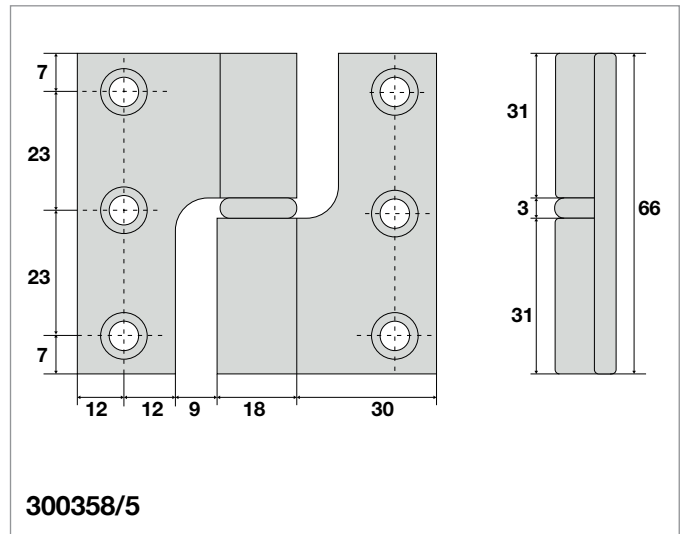
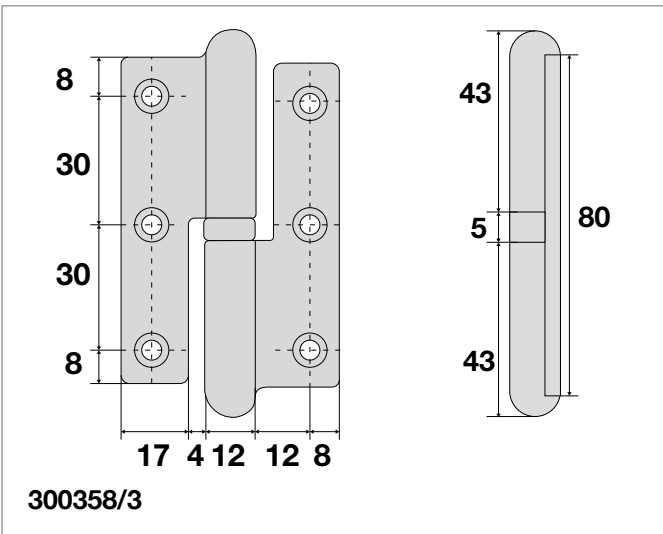

Codice / Code	Descrizione
300358/3	Cerniera a libro 80x55 ottone cromato DX
300358/4	Cerniera a libro 80x55 ottone cromato SX
300358/5	Cerniera a libro tappi rasati 65x80 ottone cromato DX
300358/6	Cerniera a libro tappi rasati 65x80 ottone cromato SX
300358/7	Cerniera a libro 80x55 ottone lucido SX
300358/8	Cerniera a libro 80x55 ottone lucido DX

CERNIERE PAUMELLES PER PORTINE DI CABINA PAUMELLES HINGES FOR CABIN DOOR

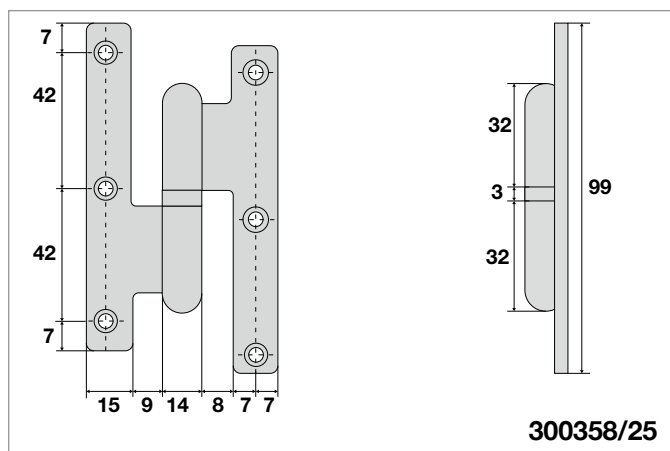
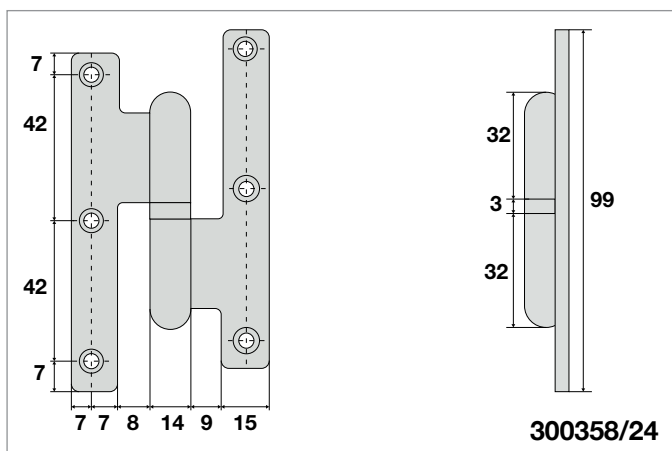

8

Codice / Code	Descrizione	Codice / Code	Descrizione
300358/14	Cerniera PAUMELLES ottone cromato 140x75 DX	300358/25	Cerniera PAUMELLES ottone lucido 100x60 SX
300358/15	Cerniera PAUMELLES ottone cromato 140x75 SX	300358/26	Cerniera PAUMELLES ottone lucido 120x70 DX
300358/16	Cerniera PAUMELLES ottone cromato 100x55 DX	300358/27	Cerniera PAUMELLES ottone lucido 120x70 SX
300358/17	Cerniera PAUMELLES ottone cromato 100x55 SX	300358/28	Cerniera PAUMELLES ottone lucido 140x75 DX
300358/18	Cerniera PAUMELLES ferro lucido 110x70 DX	300358/29	Cerniera PAUMELLES ottone lucido 140x75 SX
300358/19	Cerniera PAUMELLES ferro lucido 110x70 SX	300358/30	Cerniera PAUMELLES ottone cromato 80x50 DX
300358/20	Cerniera PAUMELLES ferro lucido 140x70 DX	300358/31	Cerniera PAUMELLES ottone cromato 80x50 SX
300358/21	Cerniera PAUMELLES ferro lucido 140x70 SX	300358/32	Cerniera PAUMELLES ottone cromato 100x60 DX
300358/22	Cerniera PAUMELLES ottone lucido 80x50 DX	300358/33	Cerniera PAUMELLES ottone cromato 100x60 SX
300358/23	Cerniera PAUMELLES ottone lucido 80x50 SX	300358/34	Cerniera PAUMELLES ottone cromato 120x70 DX
300358/24	Cerniera PAUMELLES ottone lucido 100x60 DX	300358/35	Cerniera PAUMELLES ottone cromato 120x70 SX

CERNIERE A LIBRO PIANE PER PORTINE DI CABINE FOLDING HINGES FOR CABIN DOOR

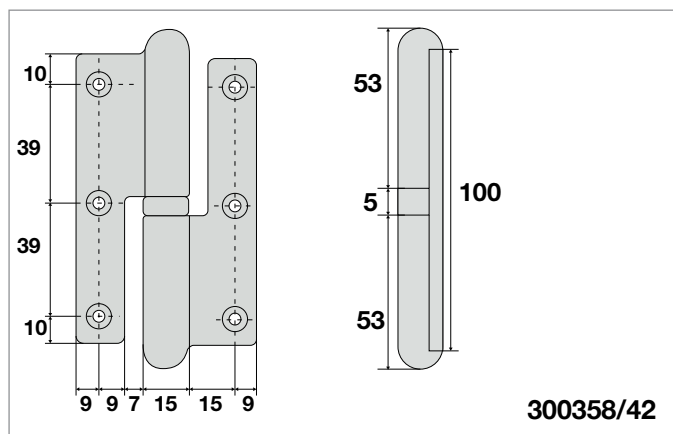
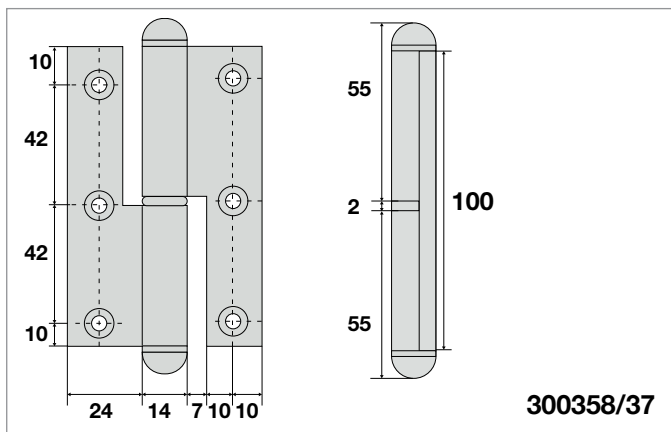
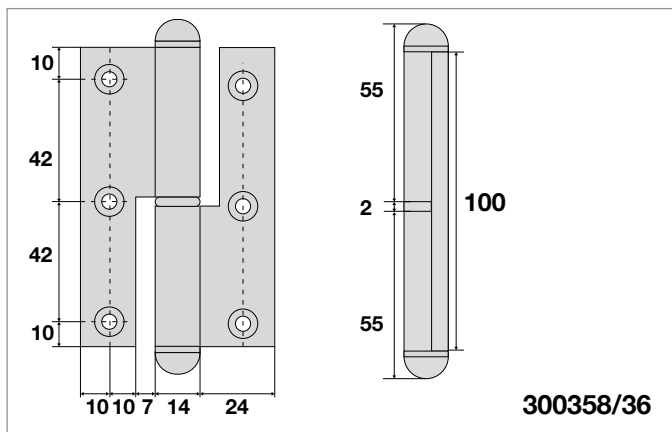

Codice / Code	Descrizione	Codice / Code	Descrizione
300358/36	Cerniera a libro piane 100x65 ferro lucido DX	300358/42	Cerniera a libro piane 100x65 ottone lucido DX
300358/37	Cerniera a libro piane 100x65 ferro lucido SX	300358/43	Cerniera a libro piane 100x65 ottone lucido SX
300358/38	Cerniera a libro piane 120x70 ferro lucido DX	300358/46	Cerniera a libro piane 140x70 ottone lucido DX
300358/39	Cerniera a libro piane 120x70 ferro lucido SX	300358/47	Cerniera a libro piane 140x70 ottone lucido SX
300358/40	Cerniera a libro piane 140x70 ferro lucido DX	300358/48	Cerniera a libro piane 100x65 ottone cromato DX
300358/41	Cerniera a libro piane 140x70 ferro lucido SX	300358/49	Cerniera a libro piane 100x65 ottone cromato SX

CERNIERE A LIBRO PIANE PER PORTINE DI CABINA FOLDING HINGES FOR CABIN DOOR

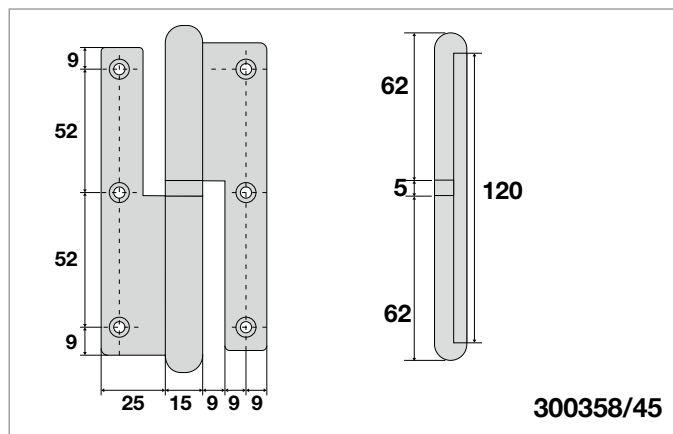
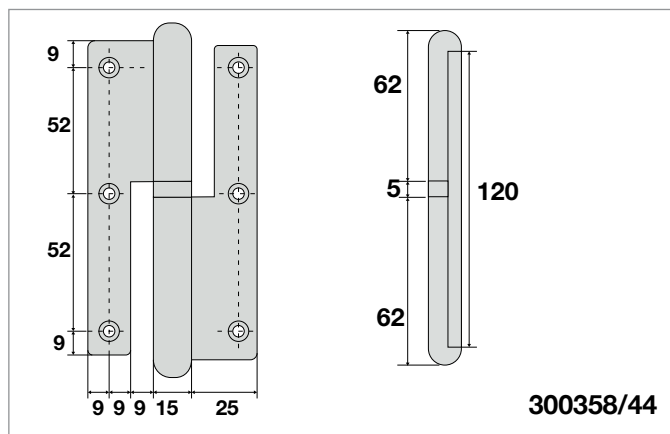
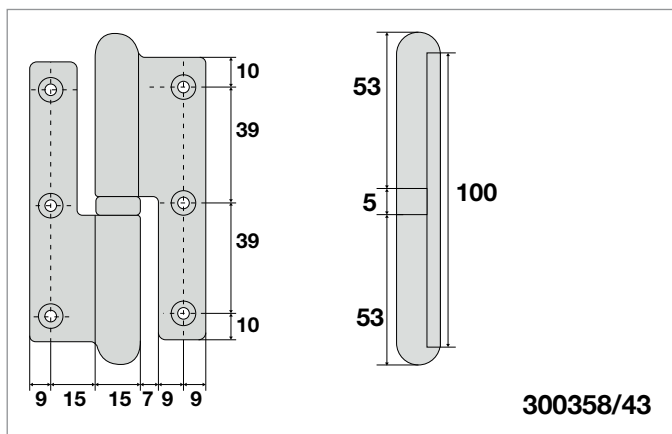

Codice / Code	Descrizione	Codice / Code	Descrizione
300358/44	Cerniera a libro piane 120x70 Ottone lucido DX	300358/54	Cerniera a libro piane 100x65 ottone bronzato DX
300358/45	Cerniera a libro piane 120x70 Ottone lucido SX	300358/55	Cerniera a libro piane 100x65 ottone bronzato SX
300358/50	Cerniera a libro piane 120x70 ottone cromato DX	300358/56	Cerniera a libro piane 120x70 ottone bronzato DX
300358/51	Cerniera a libro piane 120x70 ottone cromato SX	300358/57	Cerniera a libro piane 120x70 ottone bronzato SX
300358/52	Cerniera a libro piane 140x70 ottone cromato DX	300358/58	Cerniera a libro piane 140x70 ottone bronzato DX
300358/53	Cerniera a libro piane 140x70 ottone cromato SX	300358/59	Cerniera a libro piane 140x70 ottone bronzato SX

CERNIERE A LIBRO CON COLLO PER PORTINE DI CABINA FOLDING HINGES FOR CABIN DOOR

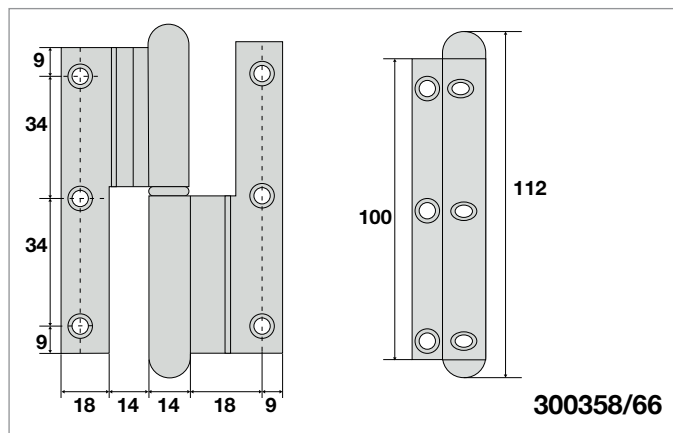
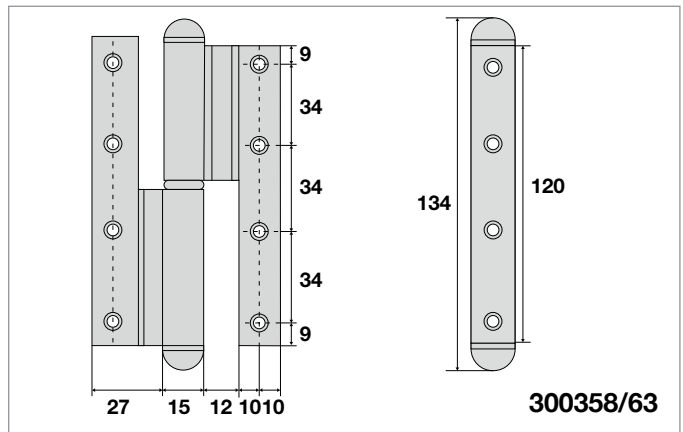
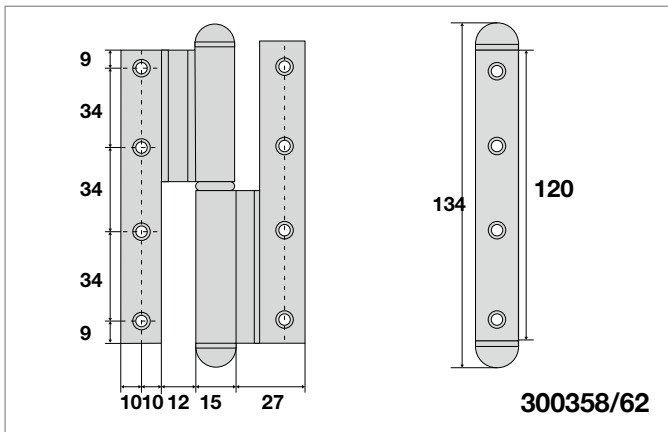

Codice	Cerniere a libro con collo	Codice	Cerniere a libro con collo
300358/60	100x65 ferro lucido DX	300358/73	100x65 ottone cromato SX
300358/61	100x65 ferro lucido SX	300358/74	120x70 ottone cromato DX
300358/62	120x70 ferro lucido DX	300358/75	120x70 ottone cromato SX
300358/63	120x70 ferro lucido SX	300358/76	140x70 ottone cromato DX
300358/64	140x70 ferro lucido DX	300358/77	140x70 ottone cromato SX
300358/65	140x70 ferro lucido SX	300358/78	100x65 ottone bronzato DX
300358/66	100x65 ottone lucido DX	300358/79	100x65 ottone bronzato SX
300358/67	100x65 ottone lucido SX	300358/80	120x70 ottone bronzato DX
300358/68	120x70 ottone lucido DX	300358/81	120x70 ottone bronzato SX
300358/69	120x70 ottone lucido SX	300358/82	140x70 ottone bronzato DX
300358/72	100x65 ottone cromato DX	300358/83	140x70 ottone bronzato SX

MANIGLIA DICTATOR ST DOOR HANDLE DICTATOR ST



La maniglia DICTATOR ST design è stata studiata basandosi sull'ergonomia della mano in modo che afferrandola le dita non picchino sulla porta. La maniglia ha tutti gli spigoli arrotondati contro il pericolo di taglio. La sua dimensione è rapportata alla porta per un migliore design.

8

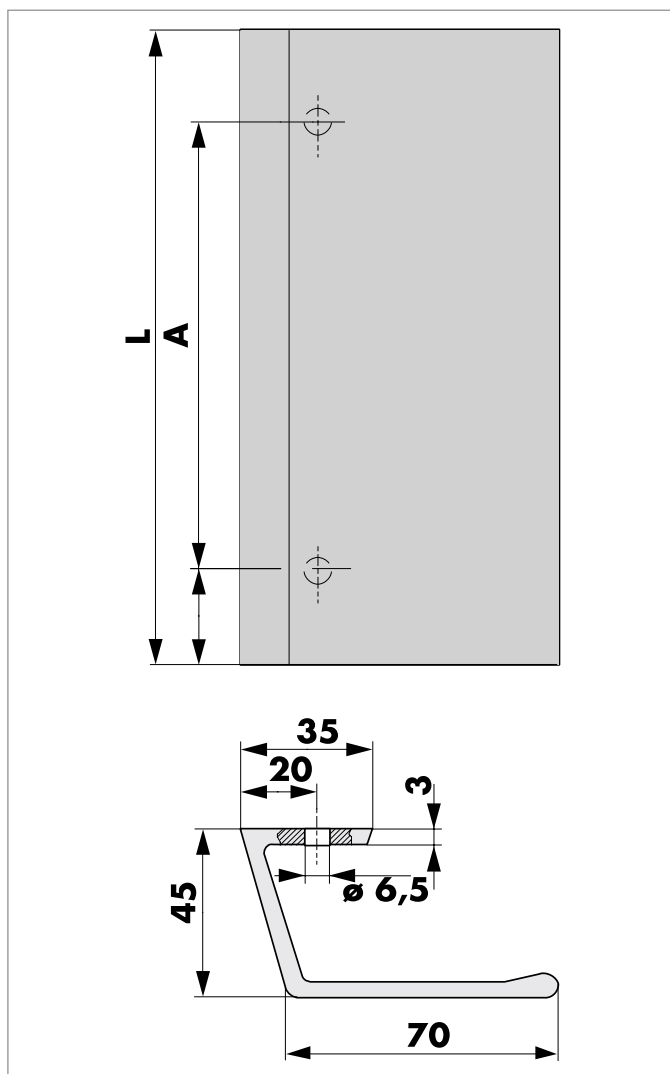
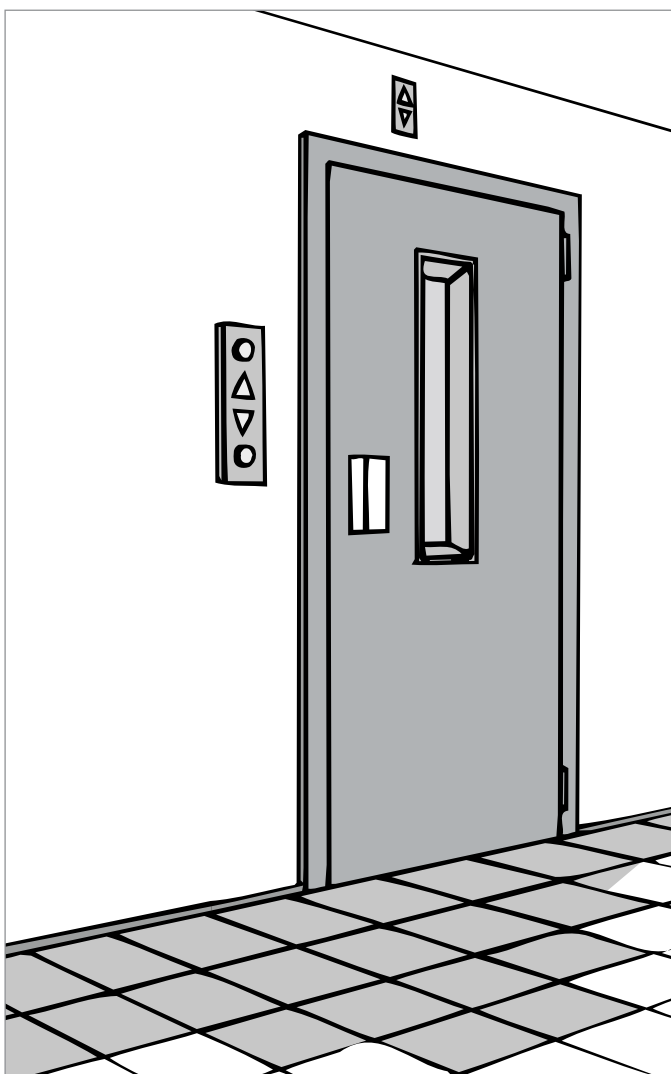

Codice / Code	A	L	Descrizione
090012	120	170	Maniglia ST Alluminio anodizzato argento
090027	100	120	Maniglia ST Alluminio anodizzato argento
090030	120	200	Maniglia ST Alluminio anodizzato argento

MANIGLIA DICTATOR S DOOR HANDLE DICTATOR S



La maniglia tubolare DICTATOR S design ha un diametro del tubolare posizionato a una distanza studiata sull'ergonomia della mano in modo che afferrandola le dita non picchino sulla porta.

La maniglia ha tutti gli spigoli arrotondati contro il pericolo di taglio.

La sua conformazione è stata studiata con un aspetto di "Design Demodé"

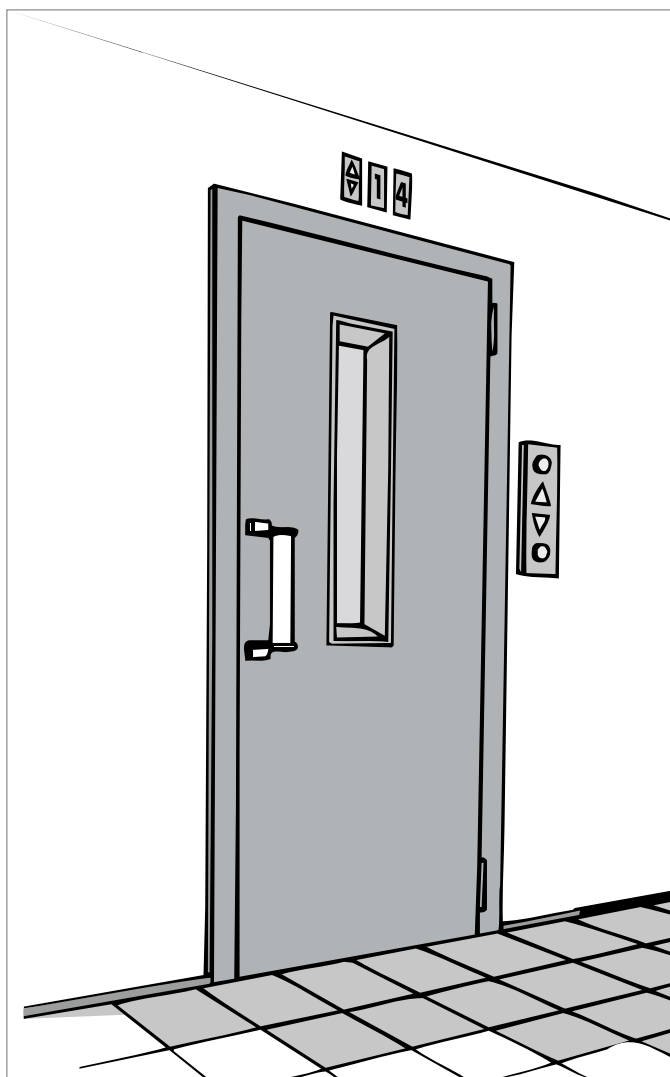
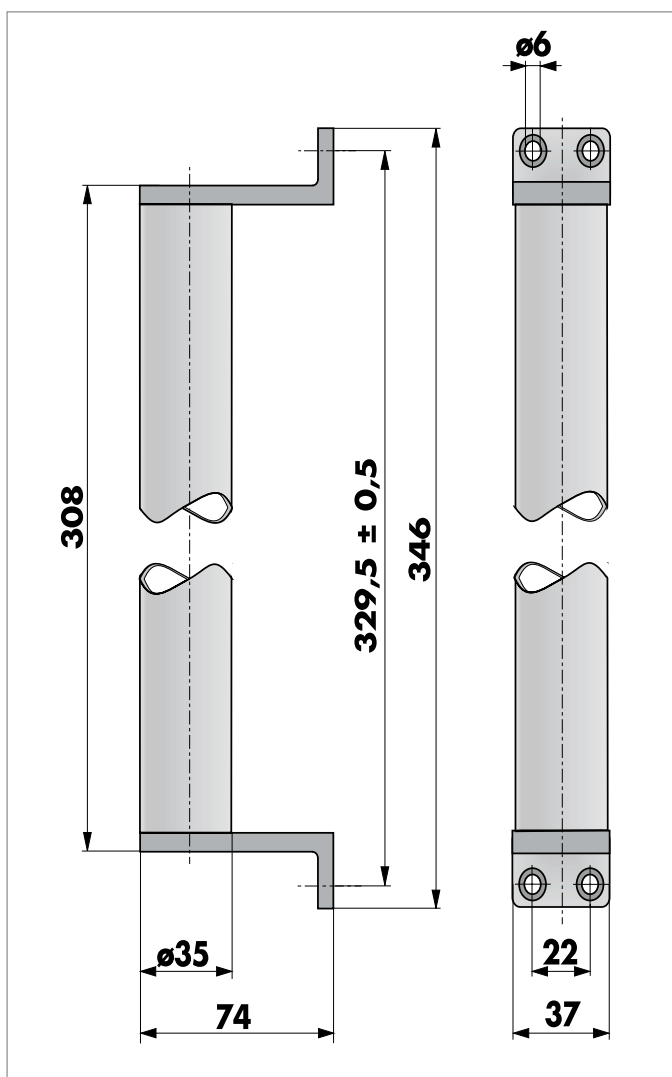

8

Codice / Code	Descrizione
090014	Maniglia S alluminio anodizzato argento

MANIGLIE VARIE PER ASCENSORI MARCHE UCE, BASSETTI, FIAM, SCHINDLER
VARIOUS HANDLES FOR LIFT UCE, BASSETTI, FIAM, SCHINDLER

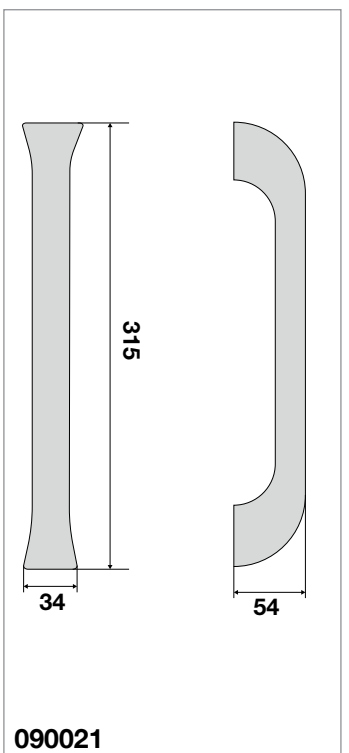
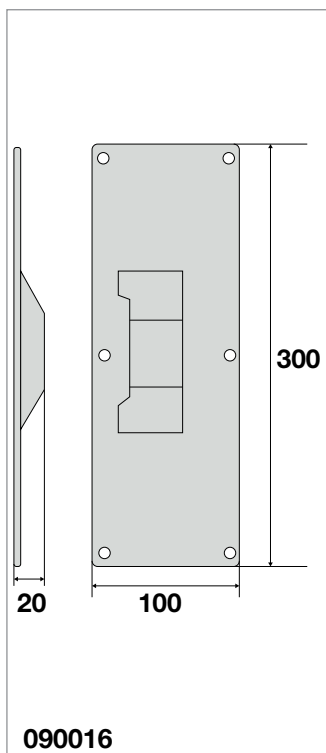
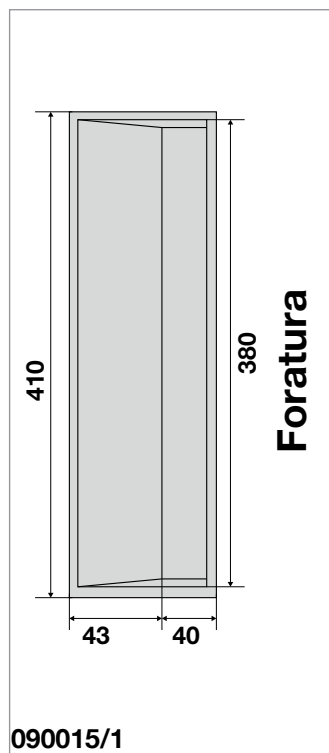
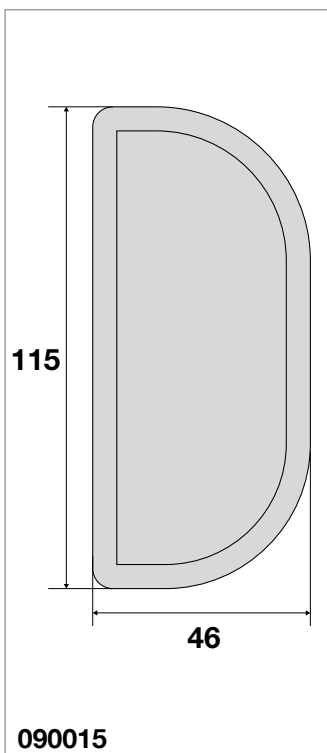
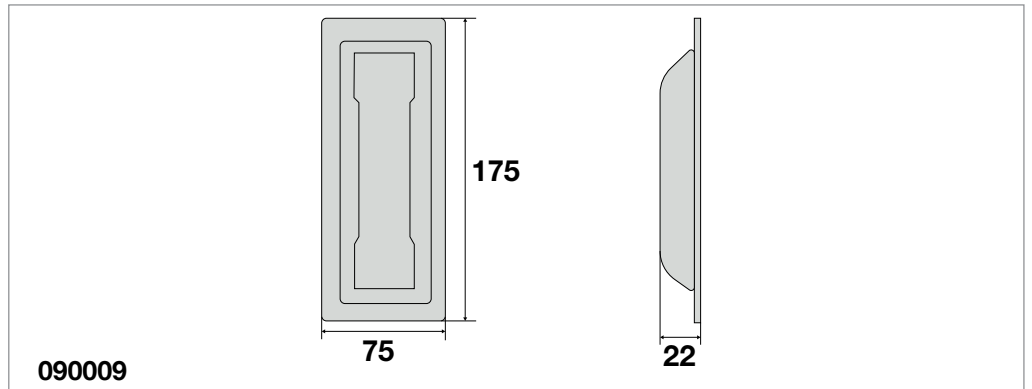

Foratura

Codice / Code	Descrizione
090009	Maniglia a incasso zincata
090015	Maniglia a incasso in plastica colore nero
090015/1	Maniglia in termoplastico colore nero per porte di piano a battente SCHINDLER
090016	Maniglia in alluminio a incasso
090021	Maniglione in termoplastico colore nero per porte a battente BASSETTI

CORNICI IN ALLUMINIO PER ASCENSORI WINDOW FRAMES FOR HINGED DOORS IN ALUMINIUM



La cornice in alluminio per porte ascensore DICTATOR, è stata realizzata con i piani di estensione inclinati, per ottenere un piacevole effetto estetico. Il montaggio è rapido e di facile esecuzione.

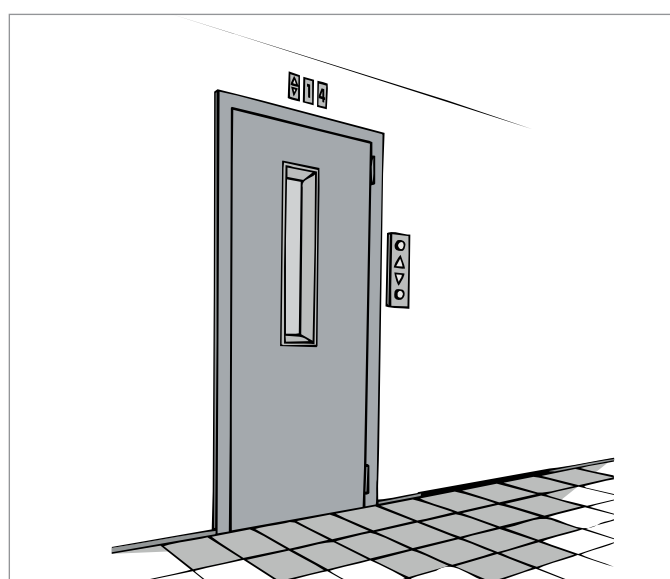
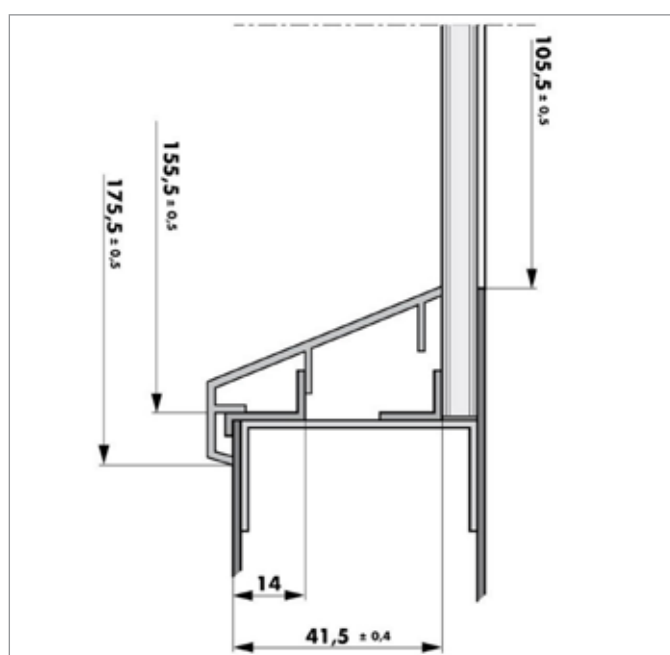
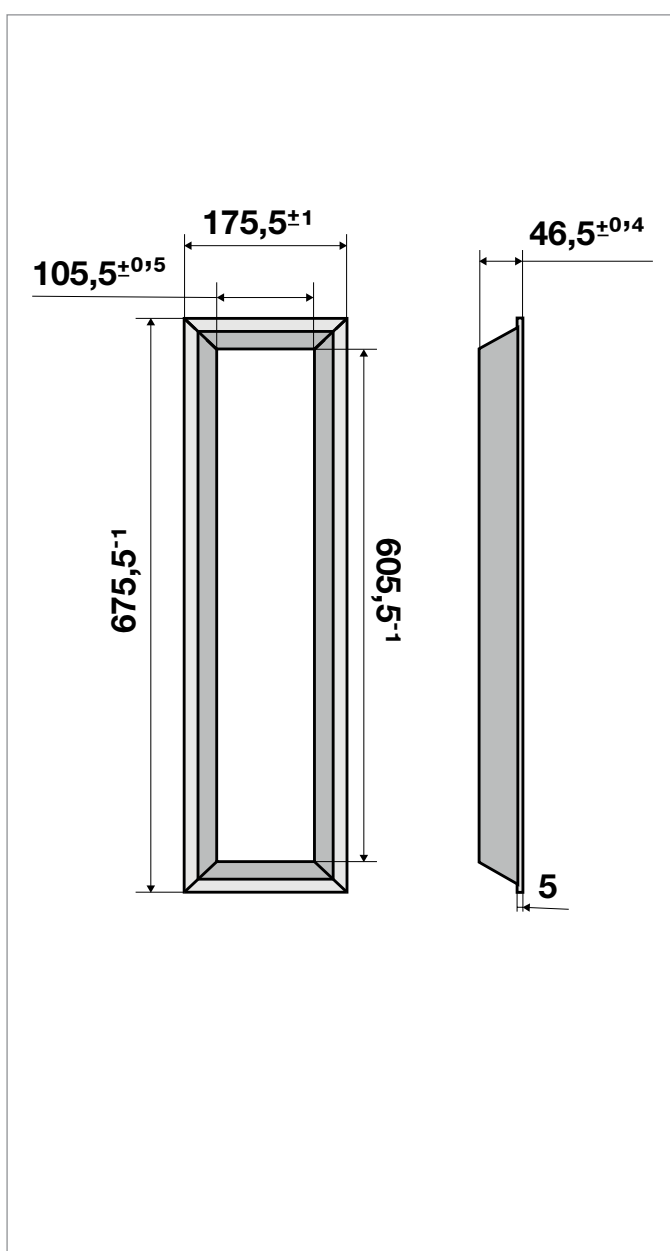

Codice / Code	Dimensioni	Colore
090001	100x600	Alluminio colore argento
090002	100x600	Alluminio colore dorato

NOTE

INTERRUTTORI DI EMERGENZA - PULSANTIERE DI PIANO E DI CABINA - PULSANTIERE DI MANUTENZIONE STANDARD E ANTIDEFLAGRANTI - PULSANTI - FRUTTO/CONTATTO - SCHERMI FOTOINCISIONI - DISPLAY
EMERGENCY SWITCHES - PUSH BUTTONS OF FLOOR AND CABIN - STANDARD PUSH BUTTONS OF MAINTENANCE AND EXPLOSION PROOF - PUSH BUTTONS - PUSH BUTTONS BASES / CONTACTS - ROUND SIGNAL DISK FILMS - DISPLAY

Interruttori d'emergenza per impianti a fune e oleodinamici	9.2
<i>Emergency switches for hydraulic rope</i>	
Pulsantiera di manutenzione con pulsante STOP - Interruttori STOP	9.3
<i>Push buttons maintenance with STOP button - STOP switch</i>	
Pulsantiera di manutenzione antideflagranti	9.3
<i>Push buttons maintenance with explosion proof</i>	
Pulsantiera di piano elettroniche extrapiatte per sostituzione rapida senza modifiche, utilizzando scatola murata in opera BASSETTI, FIAM, SAFOV + ricambi	9.4
<i>Extra flat electronic push buttons panels for quick replacement without modification, using walled box BASSETTI, FIAM, SAFOV + spare parts</i>	
Pulsantiera di piano e cabina DMG vari modelli su richiesta	9.5 - 9.6
<i>Push buttons for floor and cabin DMG in variety model on request</i>	
Pulsanti, gemme frutti/contatti per pulsantiera DMG, CEA, FIAM	9.7 - 9.8 - 9.9
<i>Buttons, gemstones push buttons/contacts for push buttons DMG, CEA, FIAM</i>	
Pulsanti, gemme e frutti SCHINDLER, FALCONI, OTIS (attenzione parte articoli in esaurimento)	9.10 - 9.11 - 9.12 - 9.13
<i>Buttons, gemstones and push buttons SCHINDLER, FALCONI, OTIS (attention some of components out of stock)</i>	
Indicatore a diodi	9.14
<i>Display</i>	

Note: I componenti sul catalogo con riportata una specifica marca di ascensore sono utilizzati abitualmente solo da questa marca. I particolari senza marca sono utilizzati da più marche di ascensori.

Note: The components in the catalogue with a specific lift brand are usually used only by the brand. Unbranded parts are used by multiple lift brands.

INTERRUTTORI SWITCHES



520



520/1



521



521/1

Interruttore monofase d'emergenza completo

Complete single-phase emergency switch

- Piastra in alluminio / *Aluminium plate*
- Vetro infrangibile / *Unbreakable glass*
- Senza scatola / *without box*

Codice / Code	Descrizione
520	Interruttore completo per impianti oleodinamici - scatola 60x60x20 mm - piastra 150x120x3 mm
520/1	Interruttore completo per impianti a fune - scatola 130x65x45 mm - piastra 210x90x3 mm

9

Interruttore monofase d'emergenza completo con scatola

Complete single-phase emergency switch

- Piastra in alluminio / *Aluminium plate*
- Vetro infrangibile / *Unbreakable glass*

Disponibilità con scritta regolamentare per impianti oleodinamici

Availability with regulatory writing for hydraulic system

Fissaggio su scatola in lamiera dim: 130x63x43mm

Fastening on metal sheet box

Codice / Code	Descrizione
521	Interruttore completo per impianti a fune - scatola 130x65x45 mm - piastra 150x90x6 mm
521/1	Interruttore completo per impianti oleodinamici - scatola 130x65x45 mm - piastra 210x90x6 mm

PULSANTIERE DI MANUTENZIONE E ADPE ANTIDEFLAGRANTE PUSH BUTTONS MAINTENANCE AND EXPLOSION-PROOF ADPE

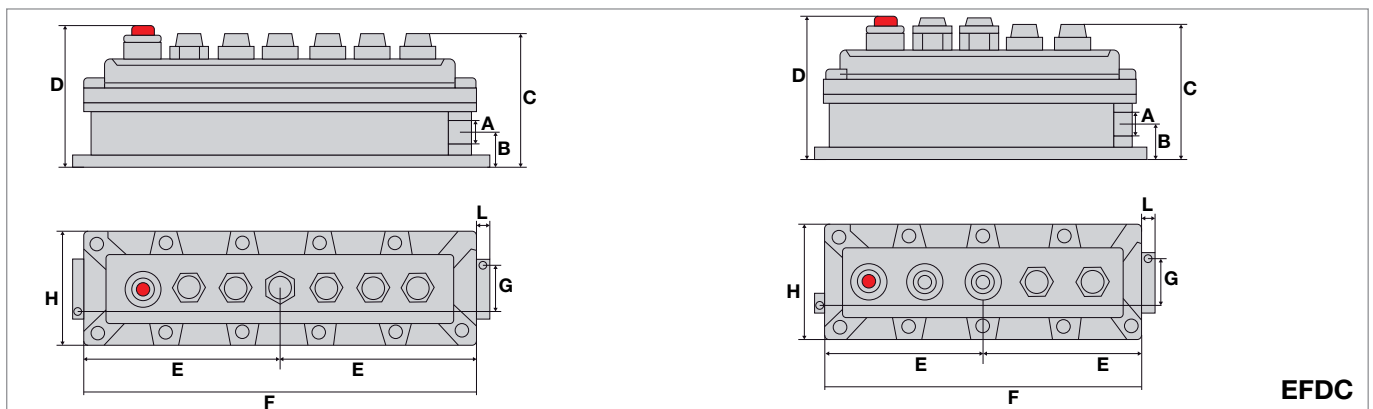

Denominazione	Dimensioni									Peso CA
	Sigla	A	B	C	D	E	F	G	H	
EFDC 8P	3/4"	32	130	—	200	412	22	108	7	5,300
EFDC 1P-6L	3/4"	32	130	140	200	412	22	108	7	5,300
EFDC	3/4"	32	130	140	200	412	22	108	7	5,300

Codice / Code	Descrizione
501	Pulsantiera di manutenzione con presa SHUCO IP 54 / Push buttons with plug SHUCO IP 54
502/1	Pulsantiera di manutenzione con presa + allarme + consenso / Push buttons with plug + alarm + consent
510	Interruttore STOP a norme IP54
522	Interruttore STOP di fossa con leva / pit switch with lever STOP button
522/1	Interruttore STOP rotativo + presa / STOP switch in circular model + plug
523	Pulsante STOP a fungo rosso stabile IP54 / STOP button in mushroom model red stable IP54
040005EX	Interruttore ATEX con STOP antideflagrante

PULSANTIERE E RICAMBI PER PULSANTIERE BASSETTI, FIAM, SAFOV PUSH BUTTON AND SPARE PARTS FOR PUSH BUTTONS BASSETTI, FIAM, SAFOV



459/BAS



459/BAS 2



459/FI



459/FI2



459/SAF



459/SAF2



460/1

9

Pulsantiera elettronica intercambiabile su pulsantiera BASSETTI, FIAM, SAFOV senza opere murarie. Dotata di circuito stampato elettronico extrapiatto consente di collegare con attacchi faston alle linee esistenti, montandola sulla scatola murata originale.

Il pulsante cieco è in grado di eseguire milioni di manovre.

Il LED occupato presente, durano anni e anni senza bruciarsi.

Alimentazione standard 4 - 12V a richiesta 24V e altre tensioni.

Interchangeable electronic push buttons on BASSETTI, FIAM, SAFOV push button without masonry work. Equipped with an extra-flat electronic printed circuit, it allows fasten connections to existing lines, mounting it on the original walled box.

The blind button is able to perform millions of manoeuvres.

The busy LED present, last for years and years without burning.

Standard 4 - 12V power supply on demand 24V and other voltages.

Codice / Code	Descrizione
459/BAS	Pulsantiera di piano BASSETTI argento
459/BAS2	Pulsantiera di piano BASSETTI oro
459/FI	Pulsantiera di piano FIAM argento
459/FI2	Pulsantiera di piano FIAM oro
459/SAF	Pulsantiera di piano SAFOV argento
459/SAF2	Pulsantiera di piano SAFOV oro
460/1	Circuito stampato per pulsanti a LED rosso (occupato) e verde (presente)

PULSANTIERE DMG PUSH BUTTONS DMG



BEETLE



BRICK



CUT



GILDA -CORNER



GILDA - SILVERLIGHT



GILDA TM



HANDY



LUNA

Codice / Code	Descrizione
BEETLE	Pulsantiera di piano a montaggio superficiale in acciaio imbutito, Dimensioni: 70x220, 90x250
BRICK	Pulsantiera di piano a montaggio superficiale in acciaio imbutito, Dimensioni: 70x220, 90x250
CUT	Pulsantiera a montaggio superficiale con schermo sagomato, Nuovo montaggio a scatto su sottopiastra (LOP) o tramite ancoraggio con cerniere laterali (COP)
GILDA - CORNER	Pulsantiera a montaggio frontale con angolari larghezze multiple, apertura a cerniera, Acciaio inox o PVD 1mm/1,5mm
GILDA - SILVERLIGHT	Pulsantiera di cabina e di piano a montaggio superficiale spessore 23mm, Testate in ABS (finitura nichel satinato o dorato lucido)
GILDA TM	Pulsantiere con piastre a montaggio frontale spessore 23mm con testate metalliche, e apertura a cerniera (200mm) o a vasistas (150mm), Acciaio inox o PVD 1mm/1,5mm
HANDY	Pulsantiera orizzontale ad elevata accessibilità (norma EN81-70), con apertura frontale a compasso, Finitura acciaio inox
LUNA	Pulsantiera a montaggio superficiale con nuovo profilo e testate piatte, Nuovo montaggio a scatto su sottopiastra (LOP) o tramite ancoraggio con cerniere laterali (COP), Testate piatte in acciaio lucido (2mm)

PULSANTIERE DMG PUSH BUTTONS DMG

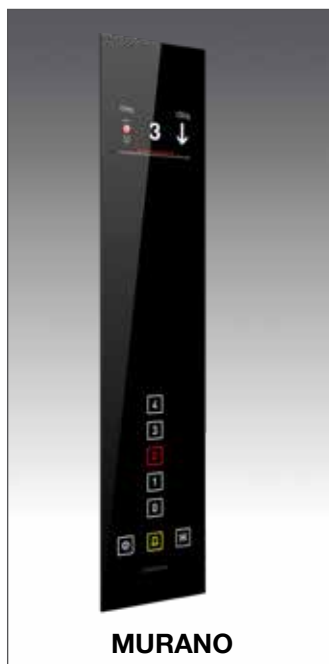

MURANO



ELISE



Piastre Piane standard



COLONNA VENUS

Codice / Code	Descrizione
MURANO TOUCH	MURANO TOUCH è la nuova linea di pulsantiere in vetro scuro temperato con l'innovativo pulsante touch a doppia illuminazione.
ELISA	Pulsantiere Piastra piana in acciaio, Acciaio inox 1.5, 2 e 3 mm con finiture Grana
PIASTRE PIANE STANDARD	Piastre piane in acciaio, Acciaio inox 1.5, 2 e 3 mm con finiture Grana
COLONNA VENUS	Piastre a montaggio superficiale con larghezze multiple, Montaggio frontale ultrarapido e apertura a cerniera, Acciaio inox o PVD 1 mm/1,5 mm

PULSANTI CEA - DMG
BUTTONS CEA - DMG



Codice / Code	Descrizione
ARCO.B	Pulsante BRAILLE area luminosa rettangolare variante colori nero/rosso/giallo
ARCO.N	Pulsante area luminosa rettangolare variante colori nero/rosso/giallo
BLOCK 37N BLOCK 37B	Pulsante Luminosa rossa, verde e gialla. Piastrina disponibile in acciaio inox, titanio lucido. 37 x 37 mm - disponibile anche nella versione BRAILLE "BLOCK 37B"
DB011 DB011/N	Pulsante DMG modello SHARON serie B5S diametro 35 mm standard 1 contatto N.A. e con incisione su specifica richiesta, oppure neutro cod. DB011/N
DL027	Gemma QD18 colore verde (presente)
DL030	Pulsante QD18 colone rosso
DL031	Pulsante quadrato QD18
LUX	Pulsante Ø 29 mm la particolarità di essere essi stessi una luminosa. La sua struttura in policarbonato trasparente ne illumina infatti tutto il corpo.
TD18	Pulsante rotondo in colore rosso - bianco - verde
TDA20	Pulsante rotondo in colore rosso - bianco - verde
RT35	Pulsante con incisione BRAILLE disponibile con diffusore luminosa in colore rossa-verde-bianco 35 x 20 mm
RTN	Pulsante rettangolare 35 x 20 mm la particolarità di essere essi stessi una luminosa. La sua struttura in policarbonato trasparente ne illumina infatti tutto il corpo

PULSANTI E GEMME FIAM BUTTONS AND GEMS FIAM



Codice / Code	Descrizione
DL001	Pulsante Ø 20
DL002	Opalino inciso Ø 20 - (specificare incisione)
DL003	Pulsante Ø 20 Giallo Allarme
DL004	Pulsante Ø 20 Rosso dicitura ALT
DL006	Pulsante Ø 16
DL007	Opalino inciso Ø 16 - (specificare incisione)
DL008/ALL	Pulsante Ø 16 Giallo Allarme
DL010	Pulsante Ø 16 verde
DL010/OCC	Pulsante Ø 16 rosso
DL011	Pulsante Ø 16 per bottoniera tipo 11 mat.UREA opalino (specificare incisione)
DL012	Pulsante Ø 16 per bottoniera tipo 11 mat.UREA opalino neutro
DL013	Pulsante Ø 16 per bottoniera tipo 11 mat.UREA opalino Allarme
DL014	Pulsante Ø 16 per bottoniera tipo 11 mat.UREA Rosso dicitura ALT

PULSANTI E GEMME FIAM BUTTONS AND GEMS FIAM

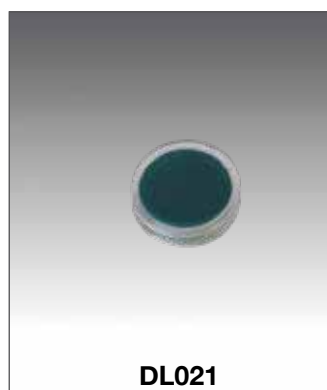

Codice / Code	Descrizione
DL015	Diffusore bottoniera Ø 16 neutro
DL016	Diffusore bottoniera Ø 16 verde
DL017	Diffusore bottoniera Ø 16 rosso
DL018	Gemma Ø 16 verde
DL019	Gemma Ø 16 rossa
DL020	Gemma Ø 16 neutra
DL021	Gemma Ø 20 verde
DL022	Gemma Ø 20 rossa
DL023	Gemma Ø 20 neutra
DL033	Pulsante antivandalo Ø 20 luminoso neutro

PULSANTI E FRUTTI SCHINDLER PUSH BUTTONS SCHINDLER



9

Codice / Code	Descrizione
DE020/1	Pulsante Ø 18 giallo, SCHINDLER
DE020/2	Pulsante Ø 18 rosso, SCHINDLER
DE020/3	Pulsante Ø 18 nero, SCHINDLER
DE020/4	Pulsante Ø 18 verde, SCHINDLER
DE020	Pulsante Ø 12 giallo, SCHINDLER
DE021	Pulsante Ø 12 rosso, SCHINDLER
DE022	Pulsante Ø 12 nero, SCHINDLER
DE023	Pulsante Ø 12 verde, SCHINDLER
DE032	Frutto per pulsante quadro SCHINDLER
DE033	Frutto per pulsante rotondo SCHINDLER

PULSANTI SCHINDLER PUSH BUTTONS SCHINDLER

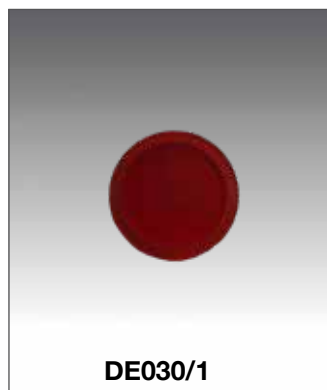

Codice / Code	Descrizione
DE026	Pulsante tondo SCHINDLER FRECCHE
DE027	Pulsante tondo SCHINDLER STOP
DE028	Pulsante tondo SCHINDLER CAMPANA
DE0281	Pulsante tondo SCHINDLER INCISO NUMERICO
DE028T	Pulsante tondo SCHINDLER INCISO LETTERALE
DE029	Pulsante tondo SCHINDLER NEUTRO
DE030	Pulsante quadro SCHINDLER NEUTRO
DE030/1	Pulsante piatto SCHINDLER ROSSO
DE031	Pulsante piatto SCHINDLER VERDE

PULSANTI FRUTTI E GEMME FALCONI PUSH BUTTONS AND GEMSTONES FALCONI



Codice / Code	Descrizione
DF001	Frutto completo pulsante "E" FALCONI ROSSO
DF002	Frutto completo pulsante "E" FALCONI VERDE
DF003	Frutto completo pulsante "E" FALCONI NEUTRO
DF004	Frutto completo pulsante "E" FALCONI INCISO (dicitura su richiesta)
DF005	Frutto completo pulsante "E" FALCONI ALT
DF006	Frutto completo pulsante "E" FALCONI STOP
DF007	Frutto completo pulsante "E" FALCONI ALLARME
DF008	Frutto completo pulsante "E" FALCONI FRECCE DIREZIONALI
DF009	Lente plastica pulsante "E" FALCONI
DF010	Gemma FALCONI VERDE
DF011	Gemma FALCONI IN ARRIVO
DF012	Gemma FALCONI FUORI SERVIZIO

PULSANTI FRUTTI OTIS PUSH BUTTONS OTIS



Codice / Code	Descrizione
DG001	Pulsante trasparente OTIS (SERIE IN ESAURIMENTO)
DG002	Frutto completo pulsante OTIS neutro
DG003	Frutto completo pulsante OTIS terra
DG003/SLOT	Frutto completo pulsante OTIS sotterraneo
DG003/ALT	Frutto completo pulsante OTIS ALT
DG003/OCC	Frutto completo pulsante OTIS occupato
DG003/PR	Frutto completo pulsante OTIS presente
DG003/AP	Frutto completo pulsante OTIS apri porta
DG003/1	Frutto completo pulsante OTIS piano 1
DG003/2	Frutto completo pulsante OTIS piano 2
DG003/3	Frutto completo pulsante OTIS piano 3
DG003/4	Frutto completo pulsante OTIS piano 4
DG003/5	Frutto completo pulsante OTIS piano 5
DG003/6	Frutto completo pulsante OTIS piano 6
DG003/7	Frutto completo pulsante OTIS piano 7
DG003/8	Frutto completo pulsante OTIS piano 8
DG003/9	Frutto completo pulsante OTIS piano 9
DG003/10	Frutto completo pulsante OTIS piano 10
DG003/11	Frutto completo pulsante OTIS piano 11
DG003/12	Frutto completo pulsante OTIS piano 12
DG003/13	Frutto completo pulsante OTIS piano 13
DG005/ALL	Frutto completo pulsante OTIS allarme

INDICATORE A DIODI DISPLAY

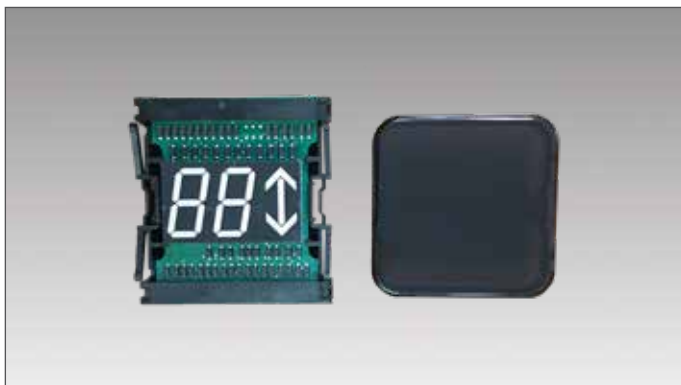

9

Codice / Code	Descrizione
D1312N	Display D13Q 55x55 12V. comune negativo
D1312P	Display D13Q 55x55 12V. comune positivo
D1324N	Display D13Q 55x55 24V. comune negativo
D1324P	Display D13Q 55x55 24V. comune positivo

RUOTE PER SOSPENSIONI E PER OPERATORI - RUOTE PER FUNI DI OPERATORE - CINGHIE PER OPERATORI
ROLLERS FOR HANGER, OPERATORS, ROLLERS FOR ROPE, BELTS FOR OPERATOR

RUOTE CON PISTA A BORDO PARALLELO O INCLINATO
ROLLER WITH PARALLEL FLANGE OR INCLINED

Ruote FALCONI, SELCOM porta automatica a bordi paralleli o inclinati 10.8
Rollers for FALCONI, SELCOM automatic door with parallel flange or inclined

Ruote OTIS, SABIEM a bordi paralleli o inclinati 10.9
Rollers for OTIS, SABIEM with parallel flange or inclined

Ruote standard a bordi paralleli o inclinati 10.10
Standard rollers with parallel flange or inclined

Ruote standard a bordi paralleli o inclinati 10.4 - 10.5 - 10.6
Standard rollers with parallel flange or inclined

Ruote standard e ruote FIAM S/2PO a bordi paralleli o inclinati 10.7
Standard rollers and FIAM S/2PO parallel flange or inclined

RUOTE CON PISTA A GOLA CONCAVA E CON PISTA PER FUNI
ROLLER WITH CONCAVE TRACK FOR ROPE

Ruote FALCONI, FERMATOR e SAFOV con pista concava 10.21
Rollers for FALCONI, FERMATOR and SAFOV with concave track

Ruote standard e OTIS per fune 10.17
OTIS and standard rollers for rope

Ruote standard con pista concava e per funi 10.11 - 10.13 - 10.14
Standard rollers with concave track for rope

Ruote standard con pista concava 10.19 - 10.20
Standard rollers with concave track

Ruote BASSETTI con pista concava o per fune 10.16
Rollers BASSETTI with concave track or for rope

Ruote standard e SELCOM con pista concava o per fune	10.15
<i>Rollers for standard and SELCOM with concave track or for rope</i>	
Ruote standard e ruota FIAM sospensione vecchia	10.12
<i>Rollers for standard and FIAM old suspension</i>	
Ruote standard, SCHINDLER e MONITOR con pista concava	10.22
<i>Roller with standard, SCHINDLER and MONITOR with concave track</i>	
Ruote SABIEM con pista concava, ruote standard pista concava	10.18
<i>Rollers SABIEM with concave track, roller standard with concave track</i>	

RUOTE A RULLO PER OPERATORI E SOSPENSIONI
ROLLER FOR OPERATION AND HANGER

Ruote a pista bombata AKRON e standard	10.27
<i>Roller with rounded track for AKRON and standard</i>	
Ruote a pista bombata per operatore e sospensione con piastre piatte e piegate SCHINDLER	10.28
<i>Roller with curved track for SCHINDLER operator and hanger</i>	
Ruote a rullo SABIEM e standard	10.23
<i>Rollers for SABIEM and standard</i>	
Ruote a rullo FALCONI	10.24
<i>Rollers for FALCONI</i>	
Ruote a rullo standard operatori e sospensioni	10.25
<i>Roller standard for operation and hanger</i>	
Ruote a rullo SABIEM	10.26
<i>Rollers for SABIEM</i>	

RUOTE A PISTA BOMBATA
ROLLER WITH CURVED TRACK

Rullo FIAM, SCHINDLER e standard	10.29
<i>Rollers FIAM, SCHINDLER and standard</i>	

RULLI PER ARCATA OLEODINAMICA
ROLLERS FOR HYDRAULIC HOISTWAY

Perni eccentrici per rullo arcate oleodinamiche 10.31
Eccentric pivot for hydraulic hoistway

Perni centrici ed eccentrici per ruote sospensioni operatori 10.32 - 10.33
Centric and eccentric pivot for roller hanger operator

Rullo per arcate oleodinamiche 10.30
Hydraulic hoistway rollers with pivot

Rullo per arcate oleodinamiche tipo OTIS.....10.30
Hydraulic hoistway rollers with pivot type OTIS

SUPPORTI PER OPERATORI
SUPPORT FOR OPERATOR

Supporti per operatori FIAM (supporto in PVC in esaurimento) 10.34
Support for operators FIAM (support in PVC out of stock)

CINGHIE SUPPORTI PER OPERATORI
BELT SUPPORT FOR OPERATOR

Cinghie per operatori, piatte rigate, trapezoidali, tonde e piatte dentate 10.35 - 10.36 - 10.37
Belts for operators, flat lines, trapezoidal, round, Toothed

Note: I componenti sul catalogo con riportata una specifica marca di ascensore sono utilizzati abitualmente solo da questa marca. I particolari senza marca sono utilizzati da più marche di ascensori.

Note: *The components in the catalogue with a specific lift brand are usually used only by the brand. Unbranded parts are used by multiple lift brands.*

RUOTE STANDARD CON PISTA A BORDI PARALLELI O INCLINATI ROLLERS STANDARD WITH PARALLEL FLANGE OR INCLINED

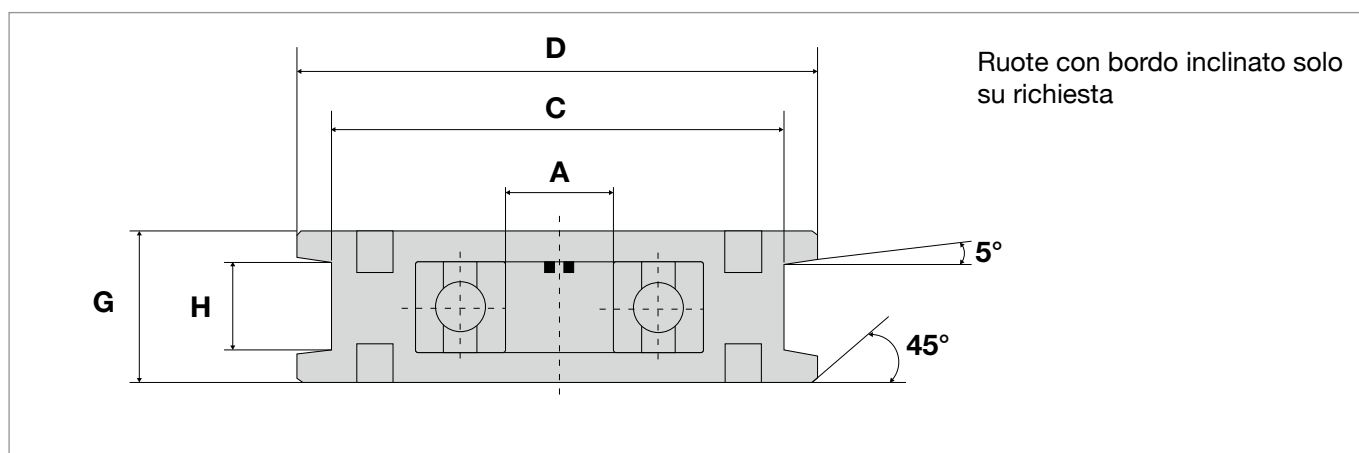

Codice / Code	A	C	H	D	G	N° Cuscinetto
8005	12	40	8	55	15	6201 2Z
8006	10	50	10	57,5	18	6200 2Z
8007	12	50	8	61	15	6201 2Z
8007/1	15	53	16	63	21	6201 2Z
8008	12	50	12	59	19	6201 2Z
8008/1	12	50	13	58	20	6201 2Z
8009	9	35	6	43	14	629 2Z
8010	12	38	10	44	16	6201 2Z
8011	10	40	8	50	17	6200 2Z
8012	10	40	10	50	17	6201 2Z
8013	12	40	10	50	17	6201 2Z
8014	12	45	8	53	14	6201 2Z
8015	12	48	10	46	17	6201 2Z
8016	17	48	10	57	21	6203 2Z
8017	12	50	10	58	17	6201 2Z
8018	15	50	10	57	13	6201 2Z
8019	12	50	8	58	17	6201 2Z
8020	17	50	8	58	20	6203 2Z
8021	17	50	10	58	21	6203 2Z
8022	17	58	12	65	21	6203 2Z

RUOTE STANDARD E FIAM CON PISTA A BORDI PARALLELI O INCLINATI
ROLLERS STANDARD WITH PARALLEL FLANGE OR INCLINED FIAM

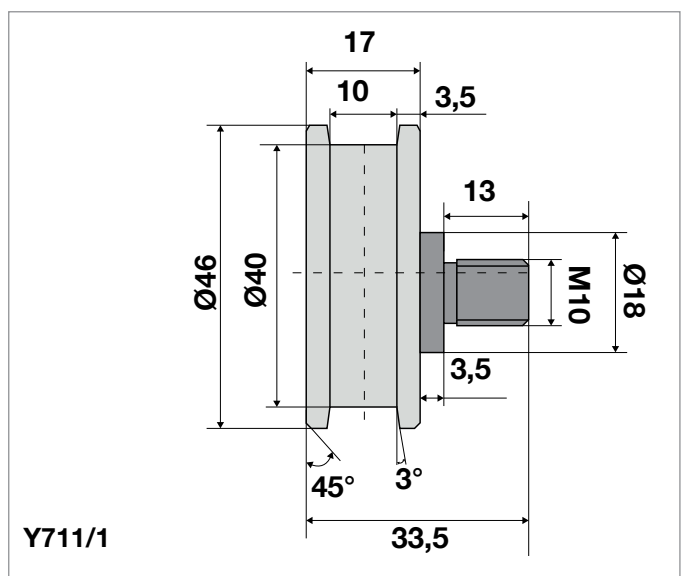
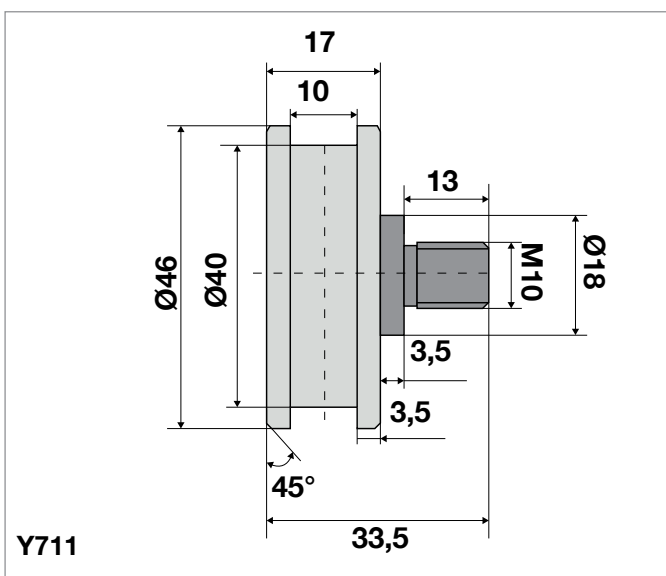
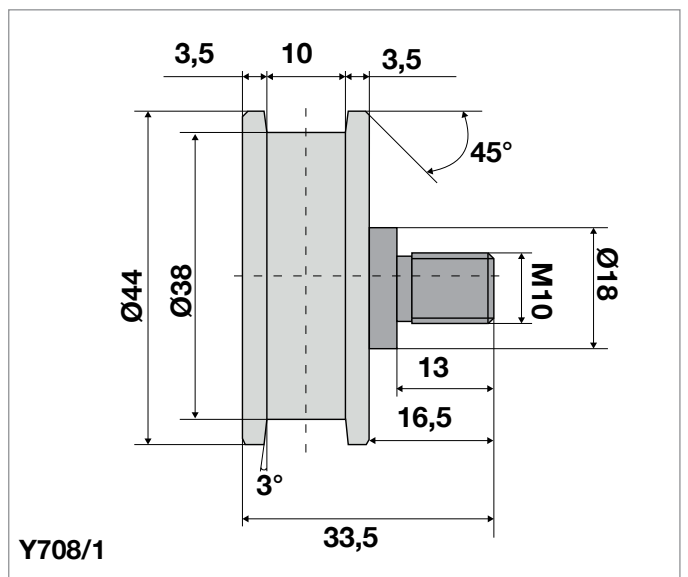
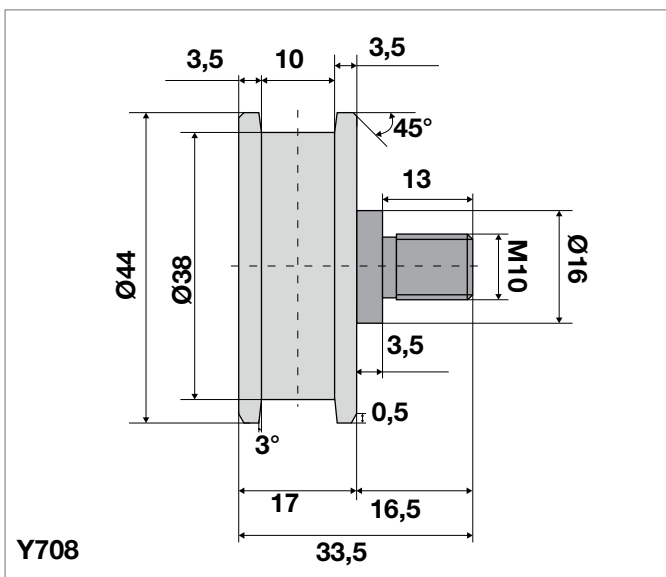

10

Codice / Code	Descrizione
Y708	Ruota 38 x 44 con perno centrico M10
Y708/1	Ruota 38 x 44 con perno eccentrico M10
Y711	Ruota 40 x 46 con perno centrico M10
Y711/1	Ruota 40 x 46 con perno eccentrico M10

RUOTE CON PISTA A BORDI PARALLELI O INCLINATI
ROLLERS WITH PARALLEL FLANGE OR INCLINED

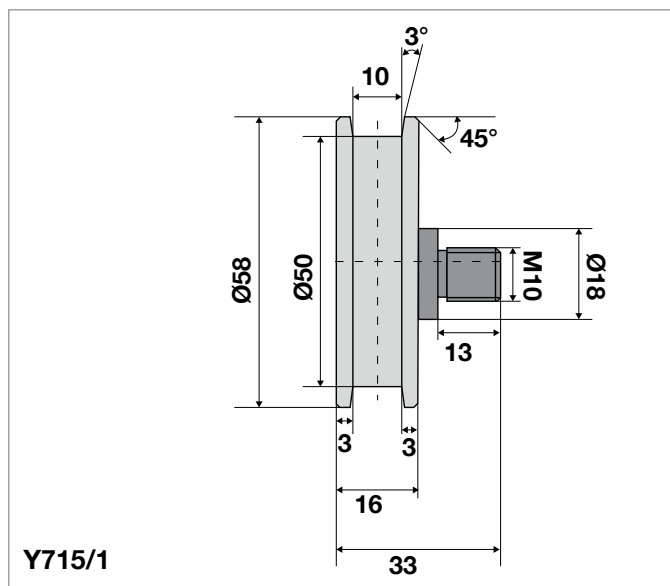
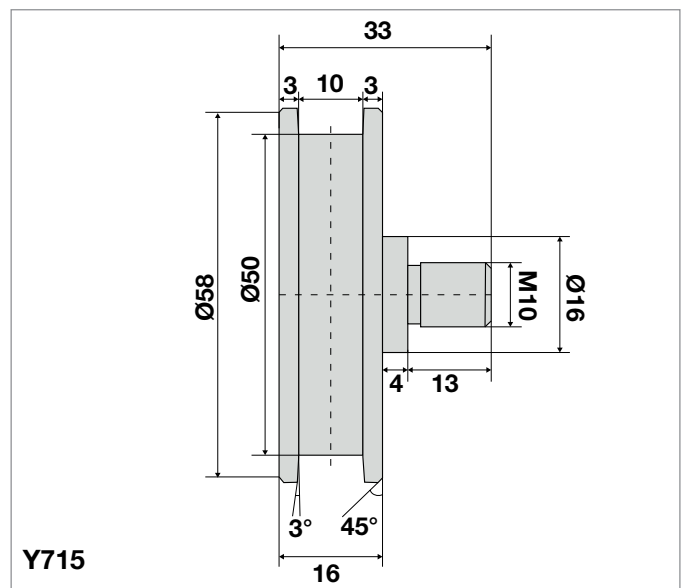
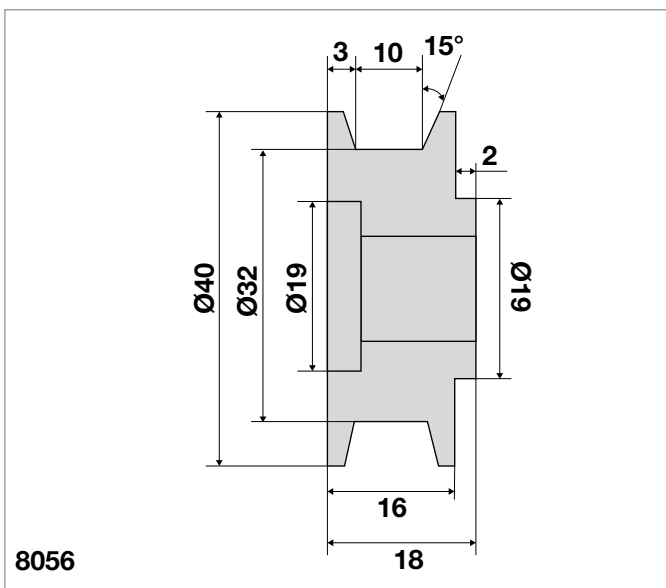

Codice / Code	Descrizione
8056	Ruota 32 x 10 F12
Y715	Ruota 50 x 58 con perno centrico M10
Y715/1	Ruota 50 x 58 con perno eccentrico M10

RUOTE CON PISTA A BORDI PARALLELI O INCLINATI
ROLLERS WITH PARALLEL FLANGE OR INCLINED

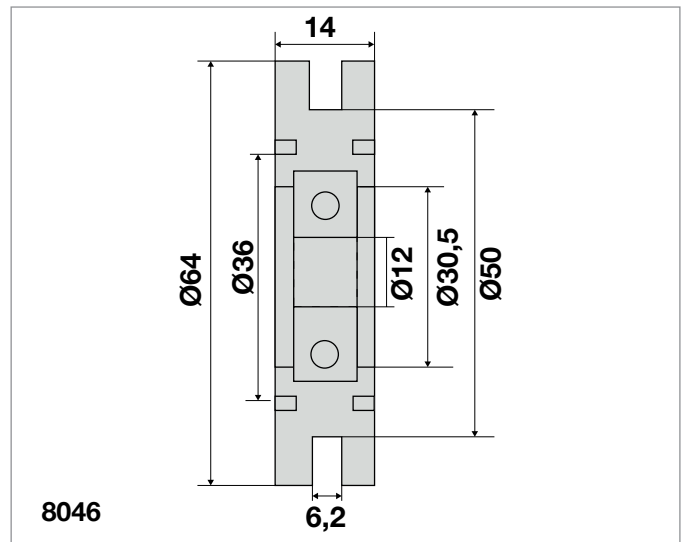
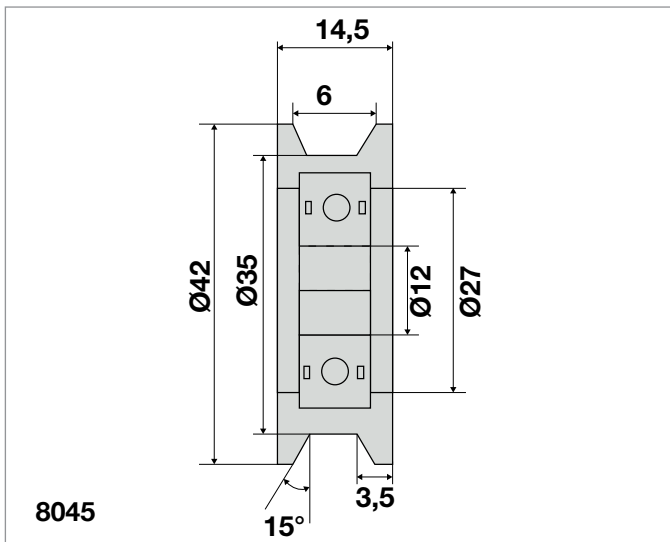
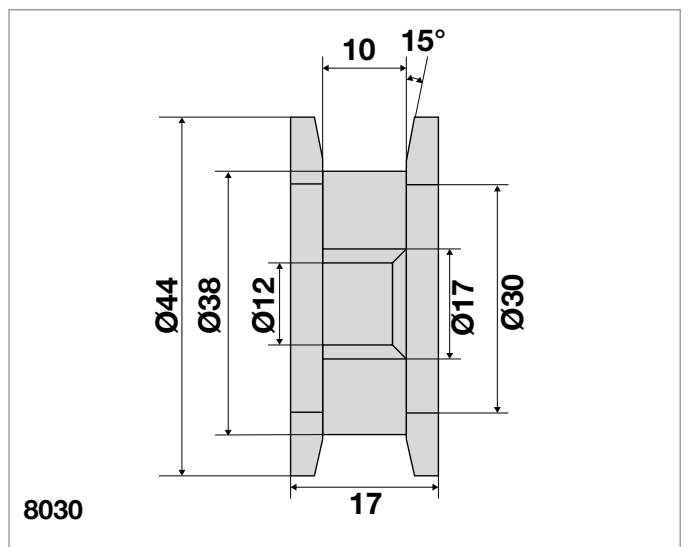
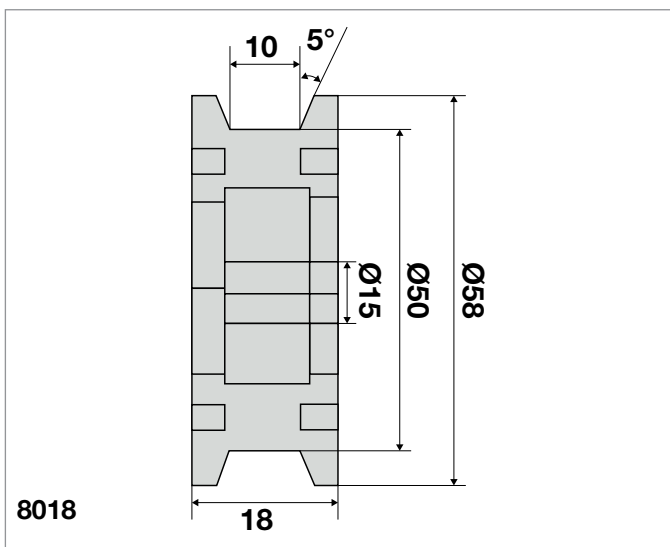

10

Codice / Code	Descrizione
8018	Ruota sospensione FIAM S/2PO 50 x 10 cuscinetto F15
8030	Ruota 38 x 10 bussole F12
8045	Ruota 35 x 6 cuscinetto F12
8046	Ruota 50 x 6 cuscinetto F12

RUOTE STANDARD, FALCONI CON PISTA A BORDI PARALLELI O INCLINATI
ROLLERS STANDARD, FALCONI WITH PARALLEL FLANGE OR INCLINED



8000



8044



8084



9000



Y14

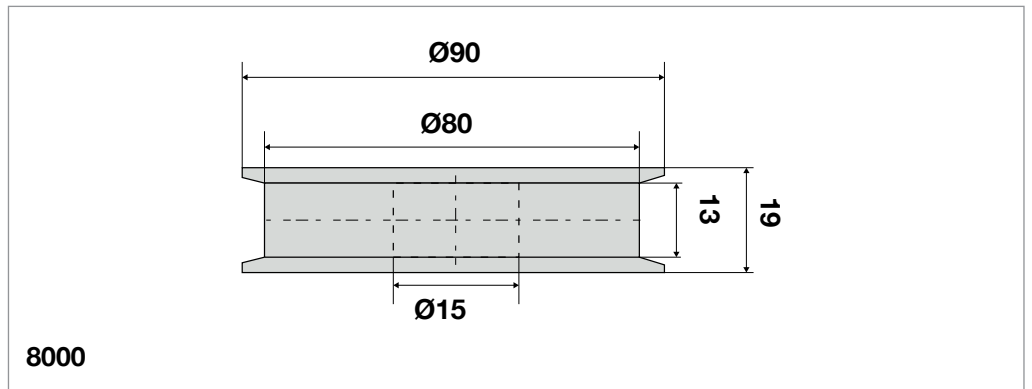

8000

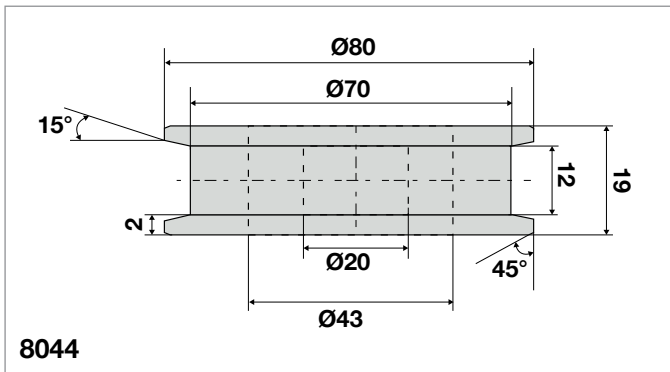

8044

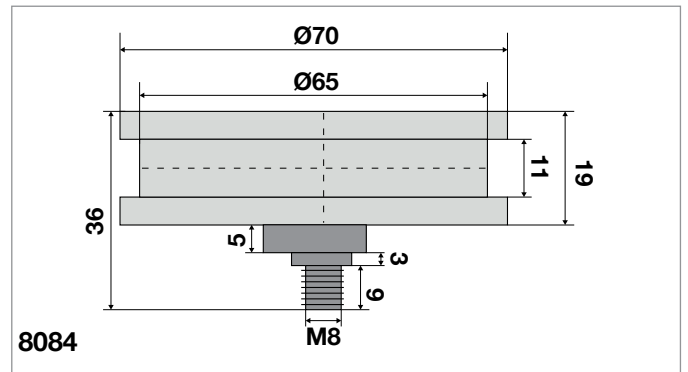

8084

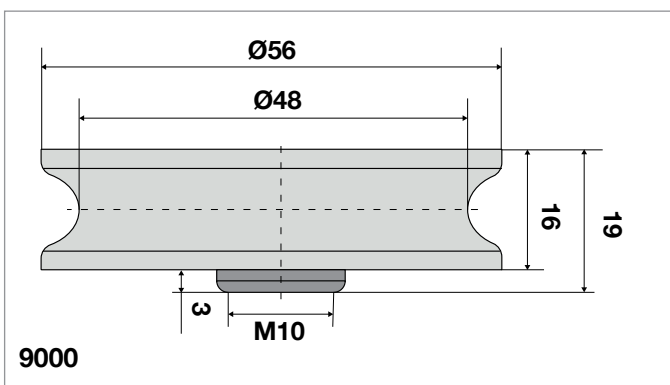

9000

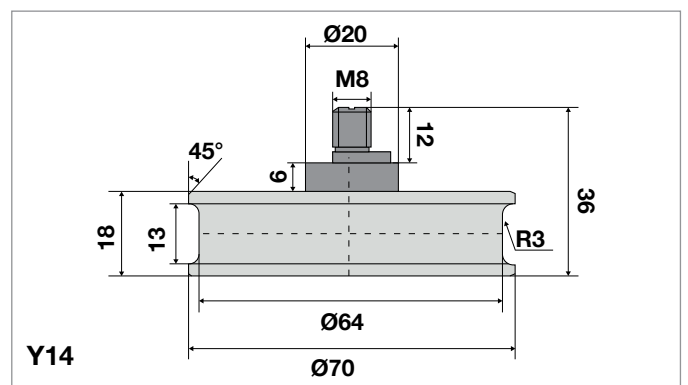

Y14

Codice / Code	Descrizione
8000	Ruota 80 x 13 F15 FALCONI
8044	Ruota 70 x 12 cuscinetto F20
8084	Ruota operatore cabina tipo P FALCONI
9000	Ruota superiore per porta automatica SELCOM
Y14	Ruota D.70 perno M8 FALCONI

RUOTE OTIS, SABIEM CON PISTA A BORDI PARALLELI O INCLINATI
ROLLERS OTIS, SABIEM WITH PARALLEL FLANGE OR INCLINED

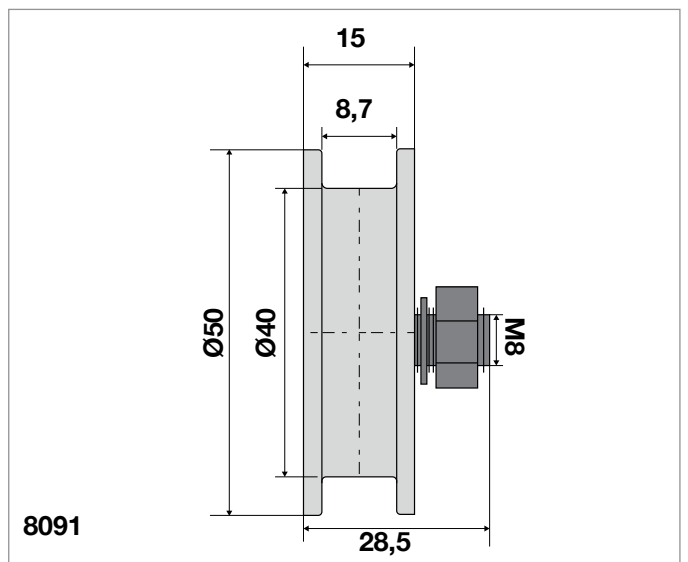
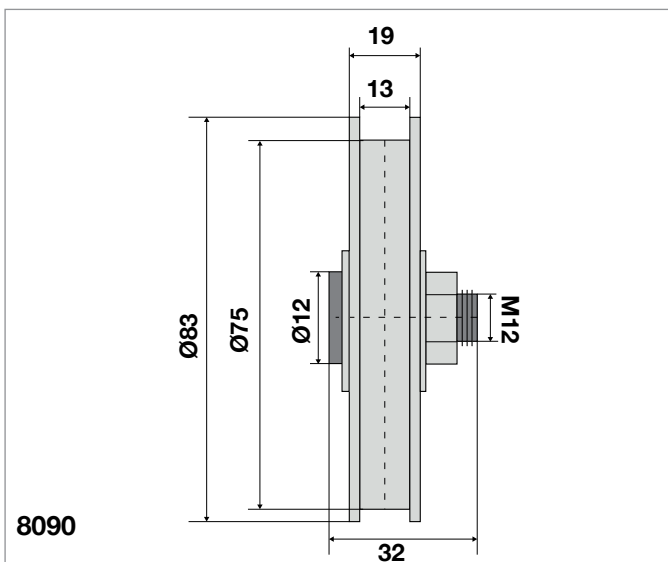
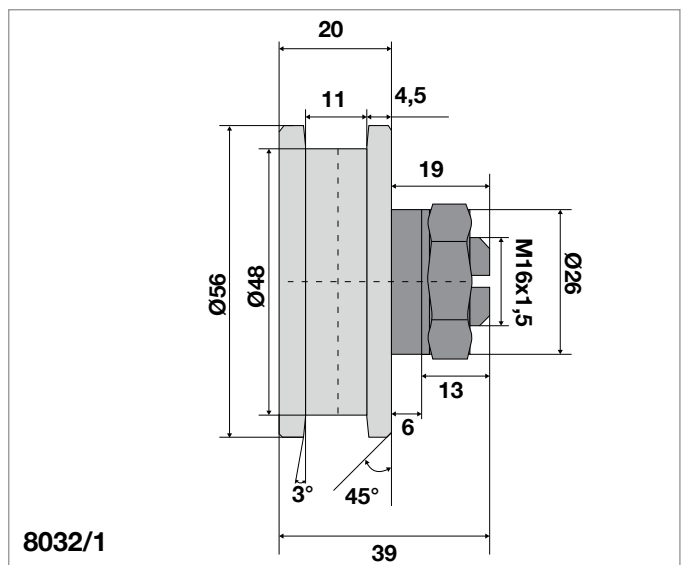
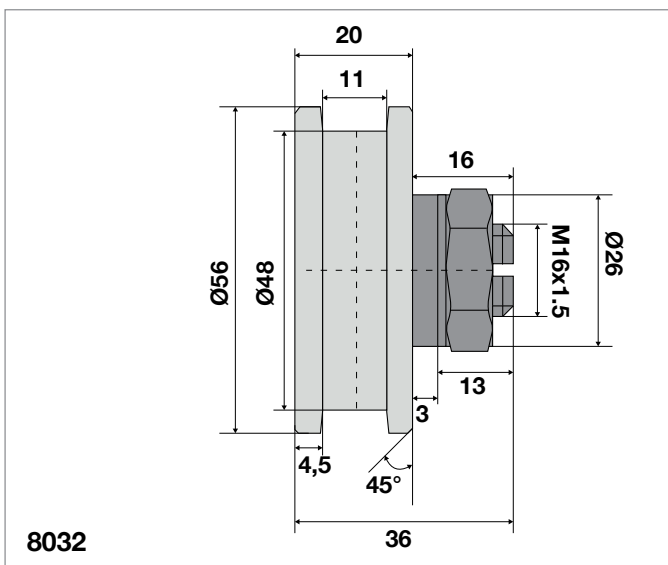
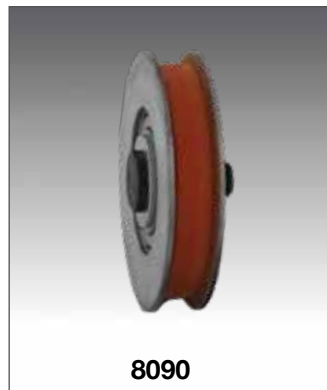
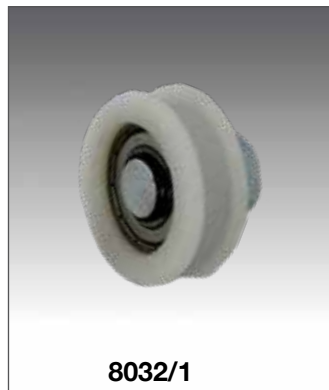

Codice / Code	Descrizione
8032	Ruota T.S 48 x 11 P.A M16 SABIEM
8032/1	Ruota T.S 48 x 11 P.B M16 SABIEM
8090	Ruota operatore OTIS
8091	Ruota con perno eccentrico per operatore OTIS

**RUOTE STANDARD CON PISTA A BORDI PARALLELI O INCLINATI
ROLLERS WITH PARALLEL FLANGE OR INCLINED**

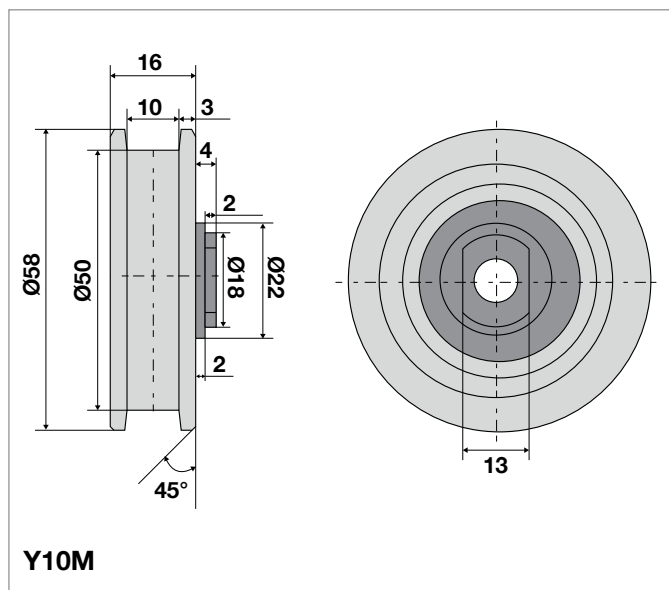
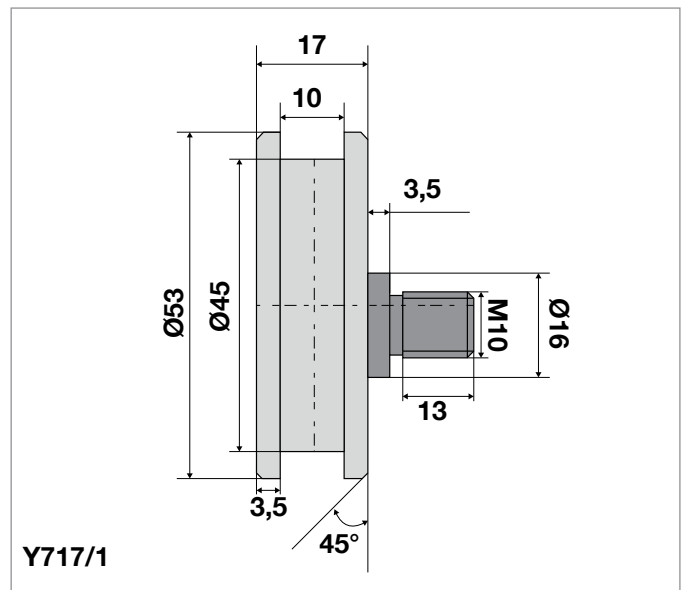
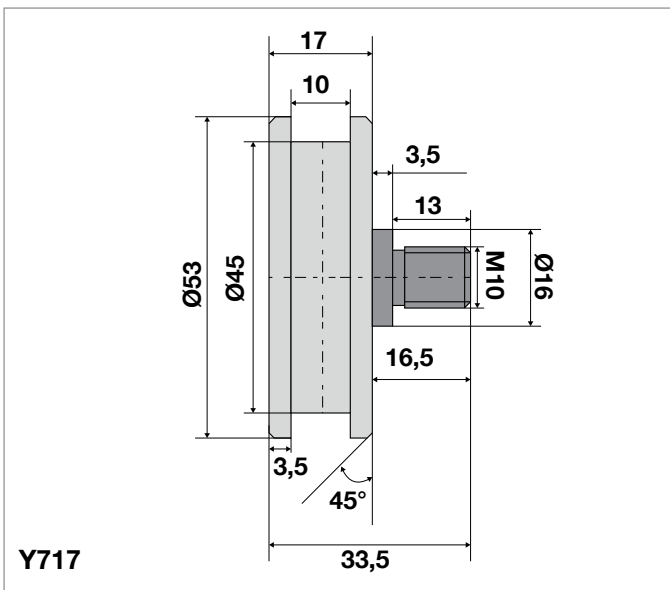

Codice / Code	Descrizione
Y717	Ruota 45 x 10 con perno centrico M10
Y717/1	Ruota 45 x 10 con perno eccentrico M10
Y10M	Ruota 296 D.50 bussola M8

RUOTE STANDARD E FIAM CON PISTA CONCAVA O PER FUNI
ROLLERS STANDARD AND FIAM WITH CONCAVE TRACK FOR ROPE

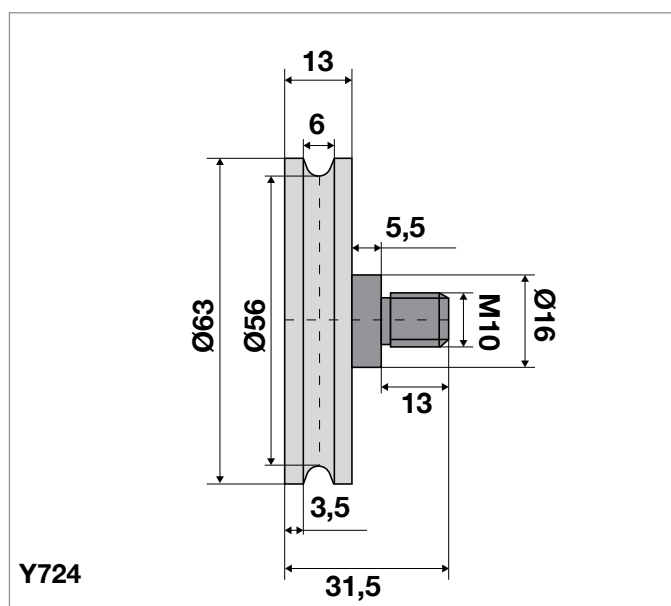
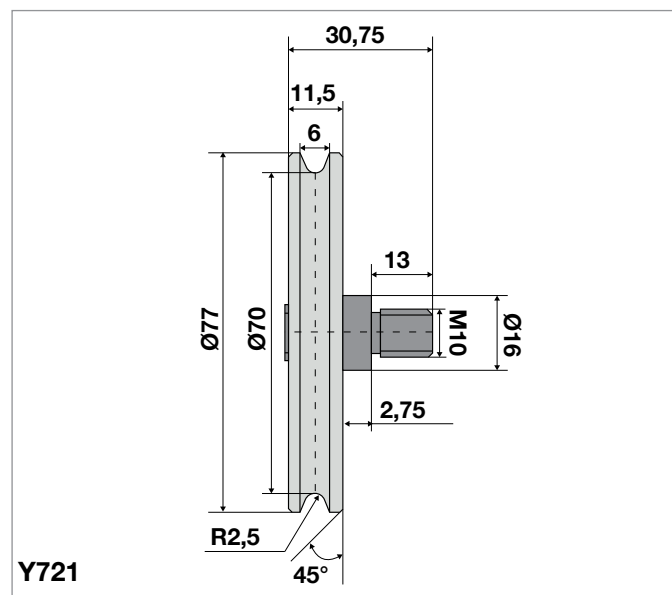
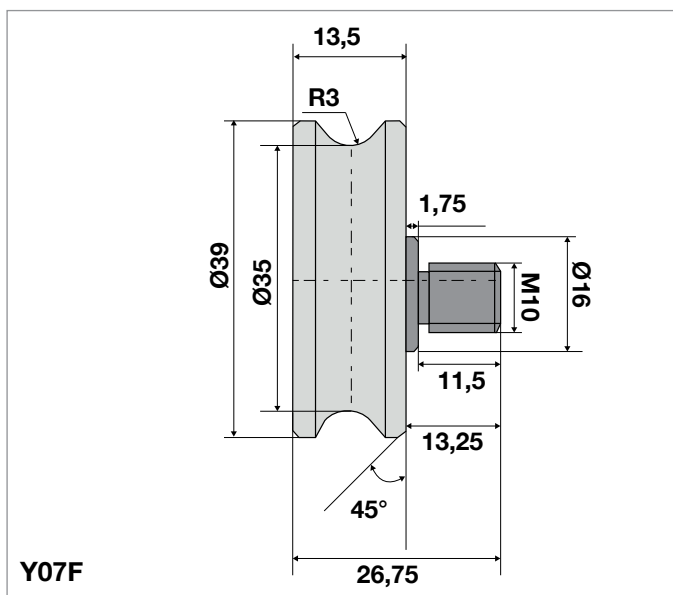
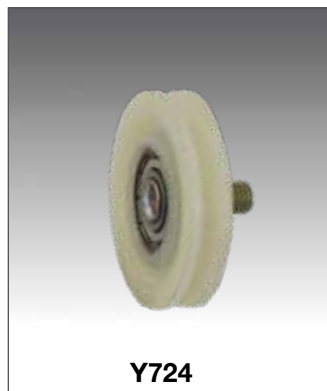
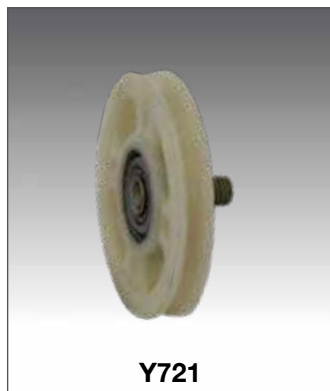

10

Codice / Code	Descrizione
Y07F	Ruota 38,1 D.35 con perno eccentrico M10
Y721	Ruota D.70 per fune perno centrato M10
Y724	Ruota D.56 per fune perno centrato M10

RUOTE STANDARD E FIAM CON PISTA CONCAVA O PER FUNI
ROLLERS STANDARD AND FIAM WITH CONCAVE TRACK FOR ROPE

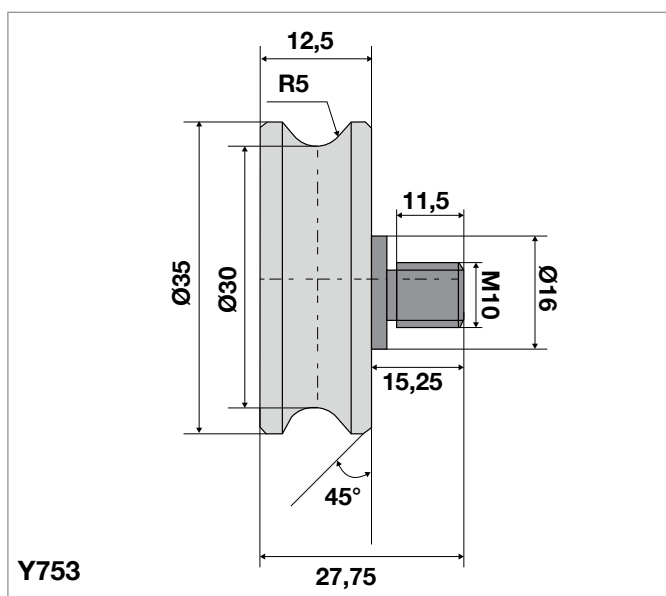
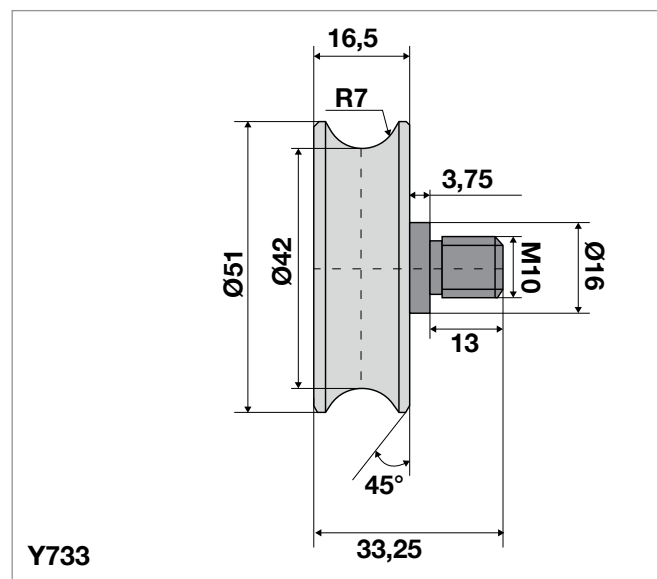
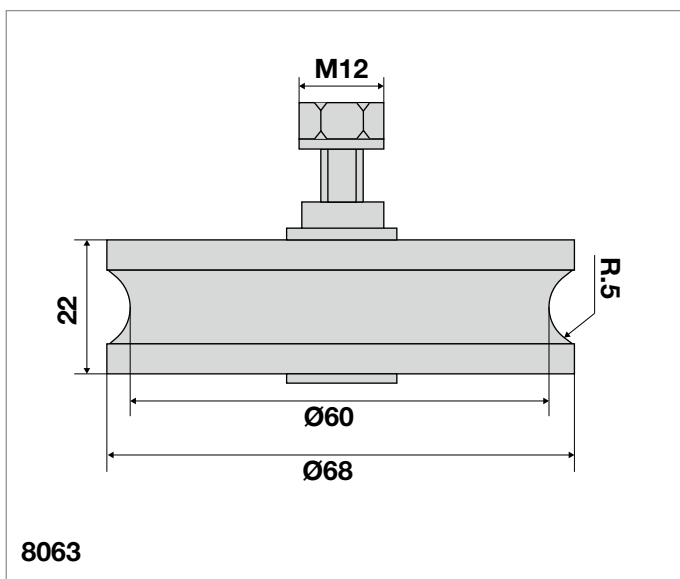
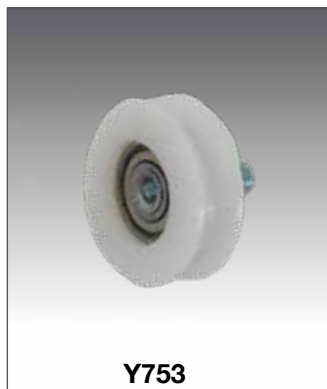

Codice / Code	Descrizione
8063	Ruota sospensione tipo vecchio FIAM
Y733	Ruota D.42 R8 perno centrico
Y753	Ruota D.30 R5 perno eccentrico M10

RUOTE STANDARD CON PISTA CONCAVA O PER FUNI
ROLLERS STANDARD WITH CONCAVE TRACK FOR ROPE

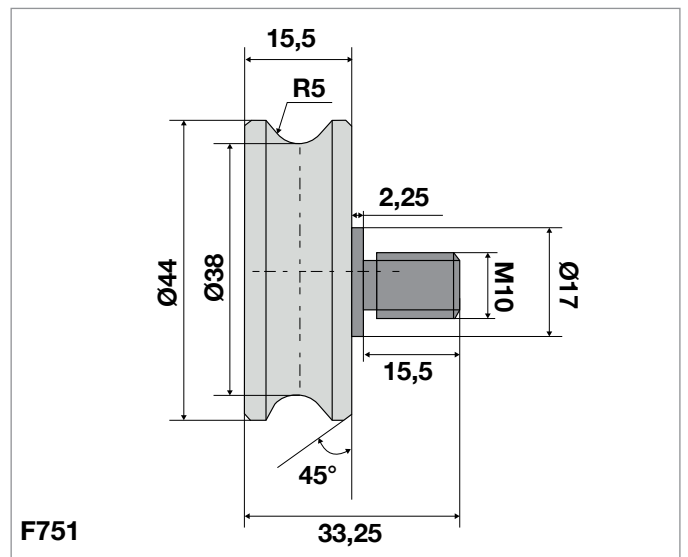
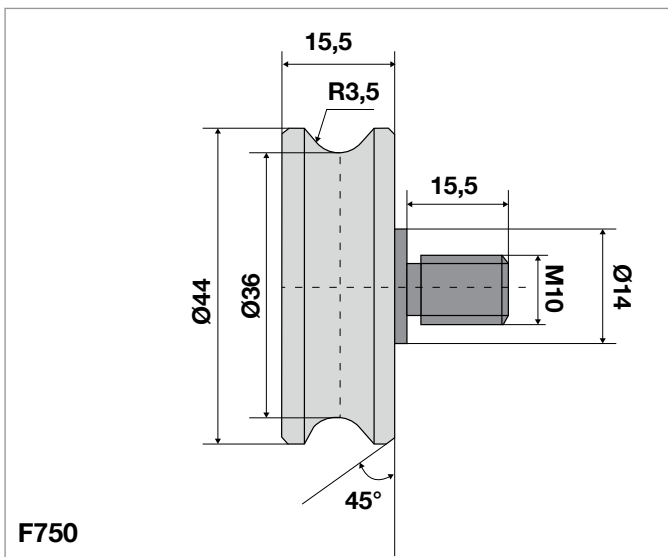
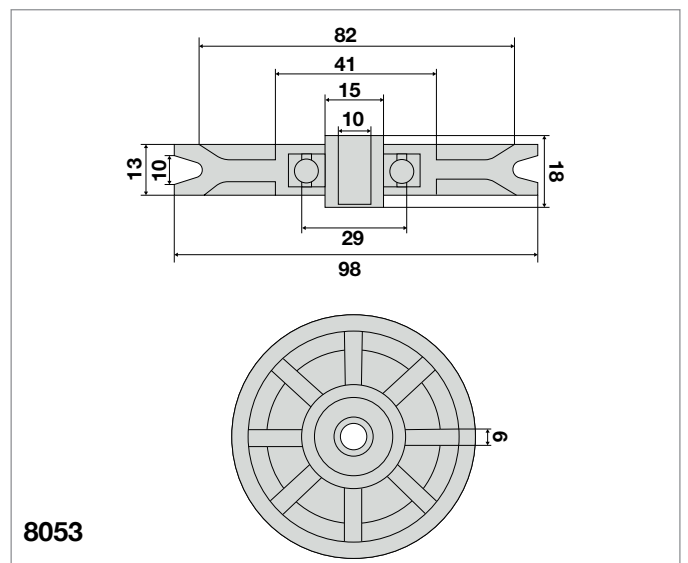
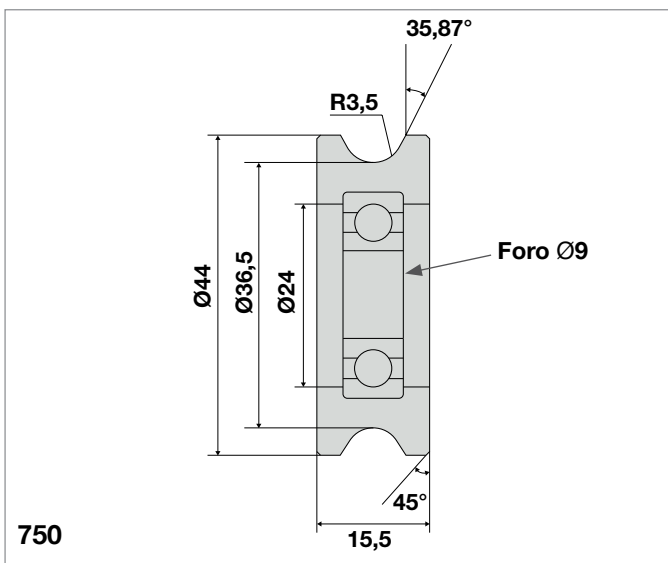
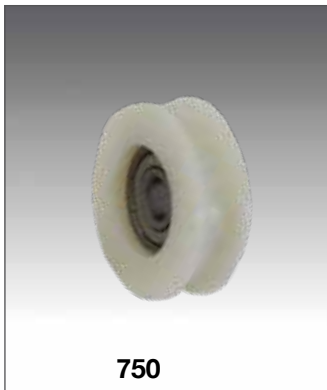

Codice / Code	Descrizione
750	Ruota D.36 R3,5 Foro Ø 9
8053	Ruota D.98 R2,5 cuscinetto F10,1
F750	Ruota D.36 R3,5 perno centrico
F751	Ruota D.38 R5,1 perno eccentrico

RUOTE STANDARD CON PISTA CONCAVA O PER FUNI
ROLLERS STANDARD WITH CONCAVE TRACK FOR ROPE



751



752



Y5S

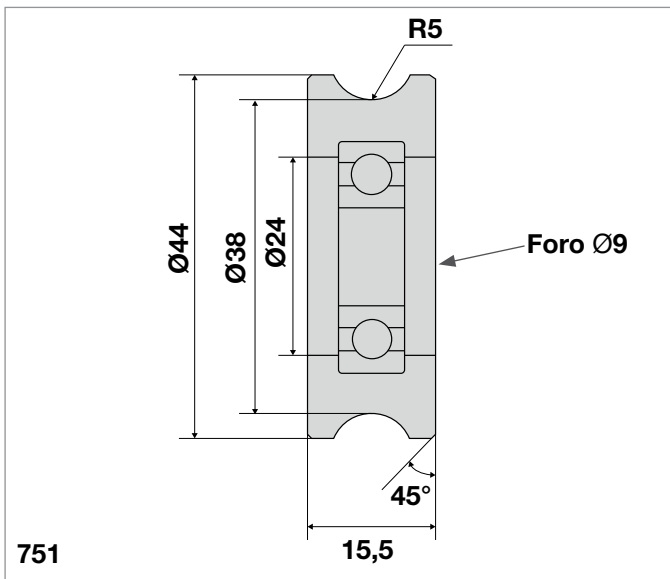

751

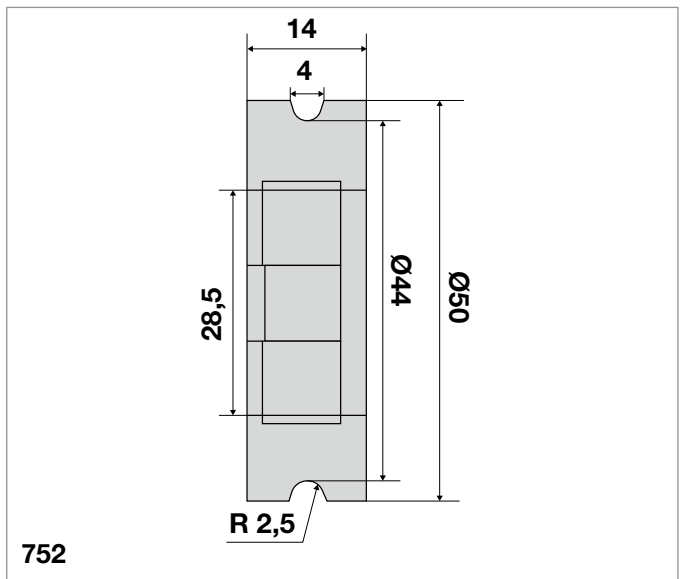

752

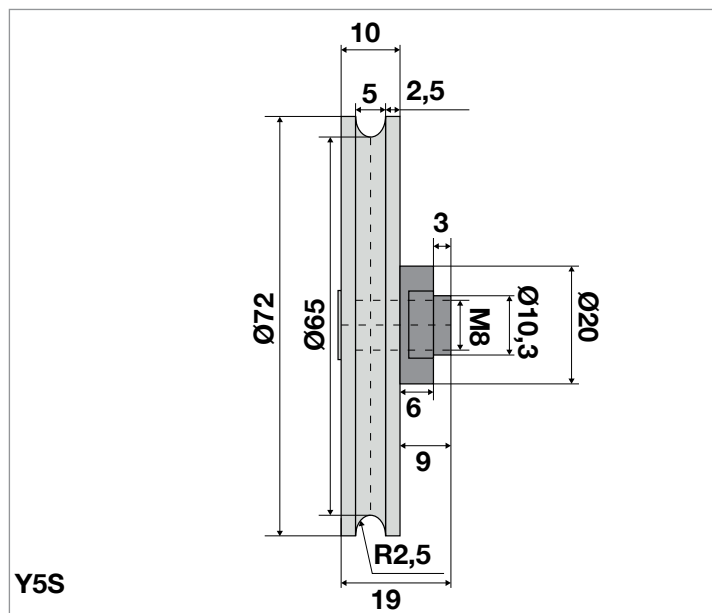

Y5S

10

Codice / Code	Descrizione
751	Ruota D.38 R5.1 Foro 9
752	Ruota per fune D.44 F10
Y5S	Ruota 922 D.65 bussola M8

**RUOTE STANDARD E SELCOM CON PISTA CONCAVA O PER FUNI
ROLLERS STANDARD AND SELCOM WITH CONCAVE TRACK OR ROPE**

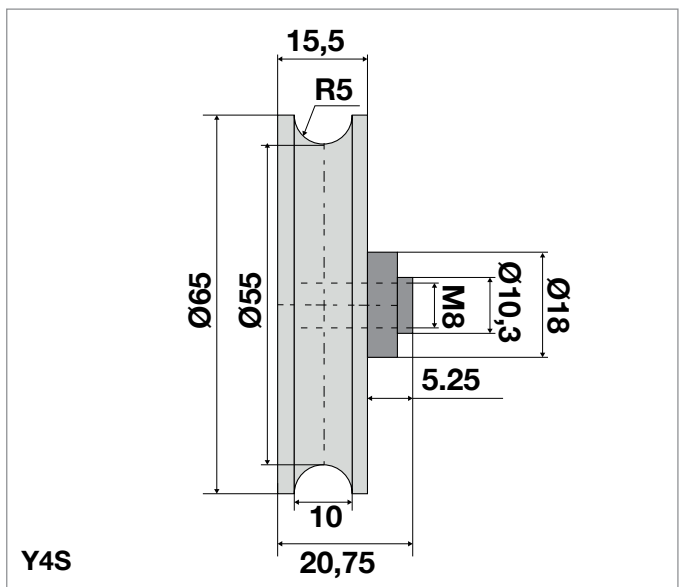
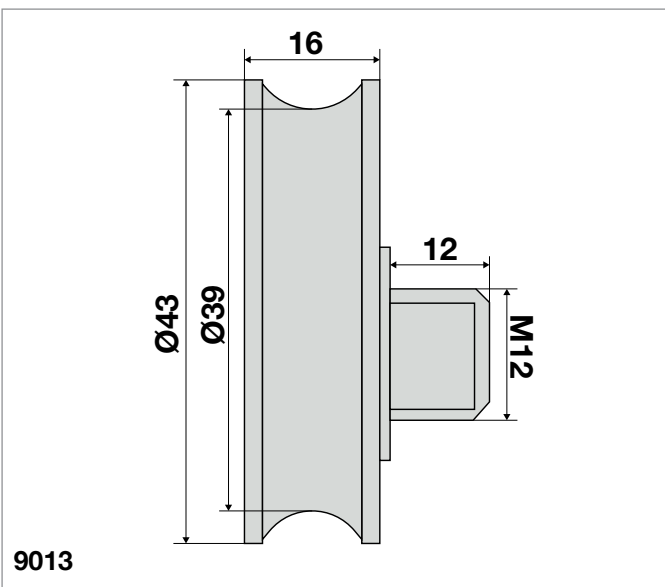
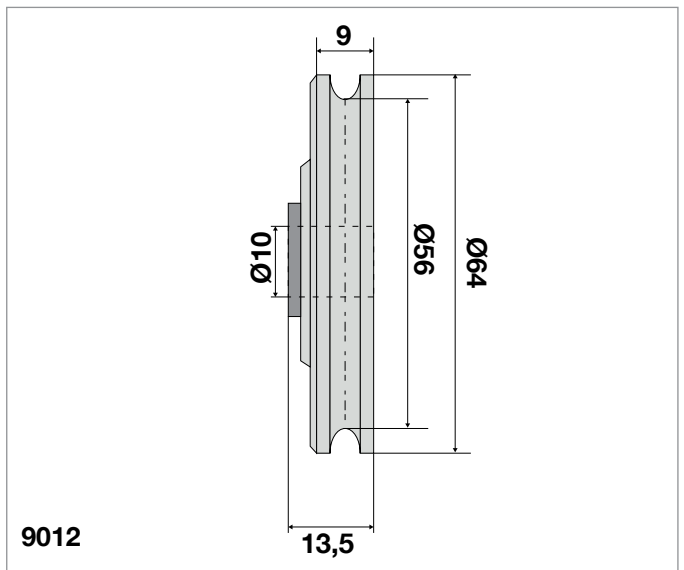
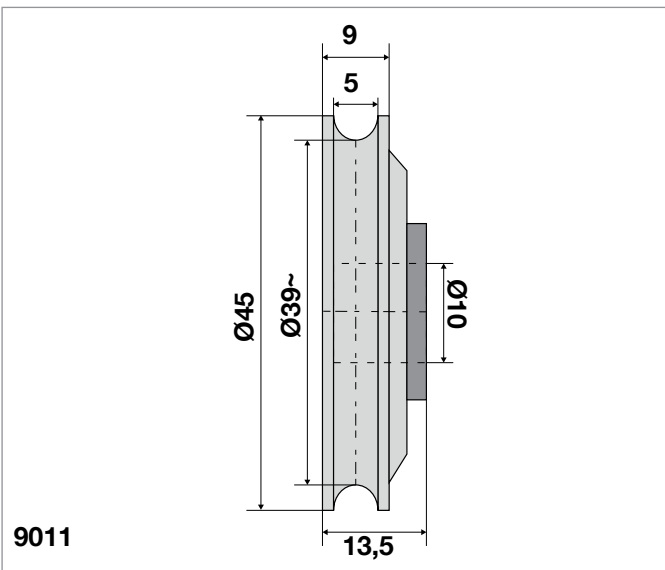

10

Codice / Code	Descrizione
9011	Ruota rinvio fune richiamo sospensioni SELCOM
9012	Carrucola rinvio fune per porta automatica SELCOM
9013	Rotella inferiore con perno eccentrico per porta automatica SELCOM
Y4S	Rotella 382 D.55 bussola M8

RUOTE STANDARD E BASSETTI CON PISTA CONCAVA O PER FUNI
ROLLERS STANDARD AND BASSETTI WITH CONCAVE TRACK OR ROPE

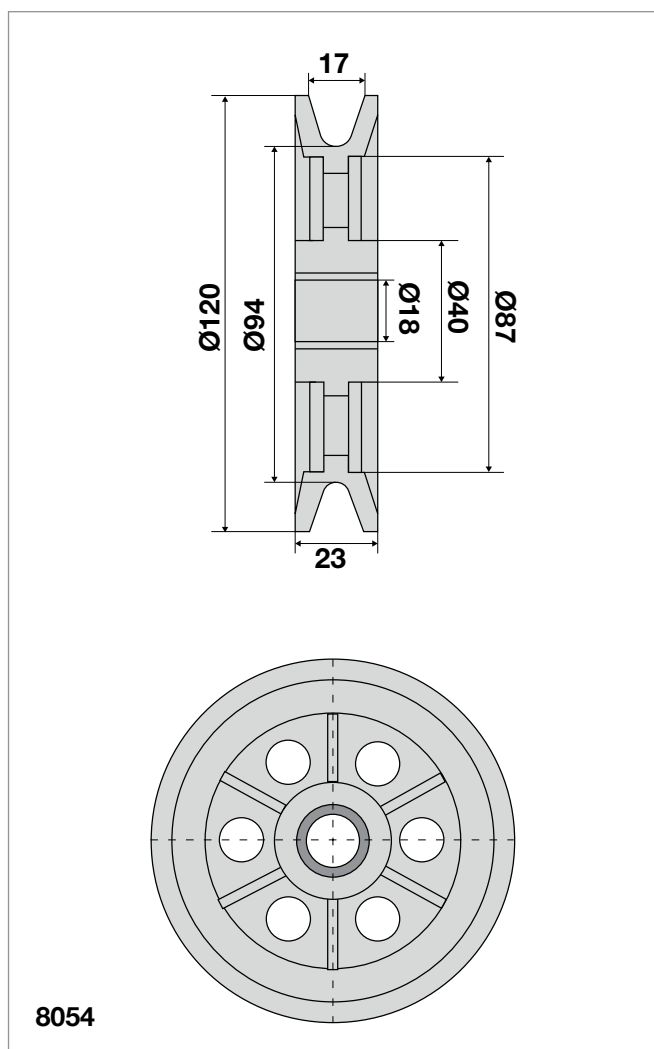
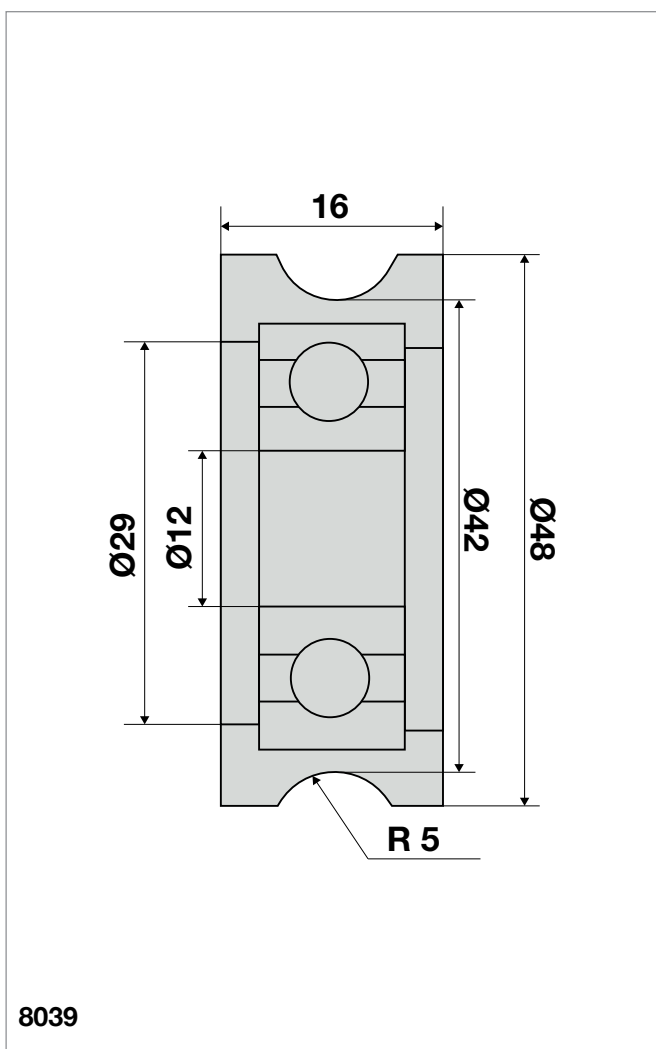

10

Codice / Code	Descrizione
8039	Ruota D.42 R5 cuscinetto F12 BASSETTI
8054	Rotella D.120 R2,5 con bussola in ottone F18 BASSETTI

**RUOTE STANDARD E OTIS CON PISTA CONCAVA O PER FUNI
ROLLERS STANDARD AND OTIS WITH CONCAVE TRACK OR ROPE**

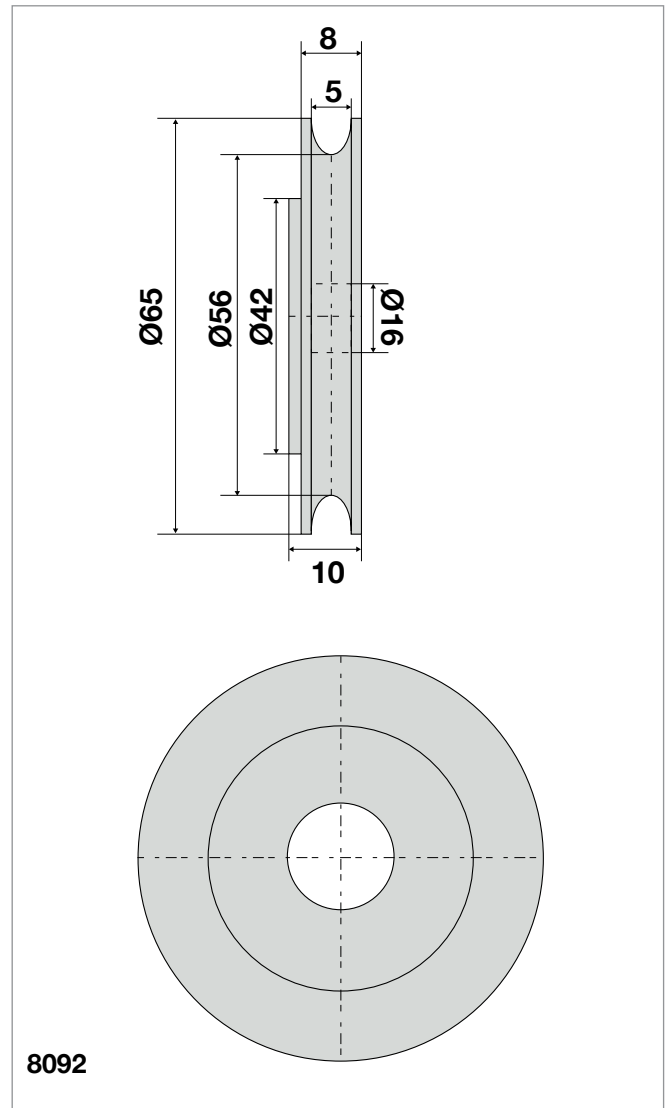
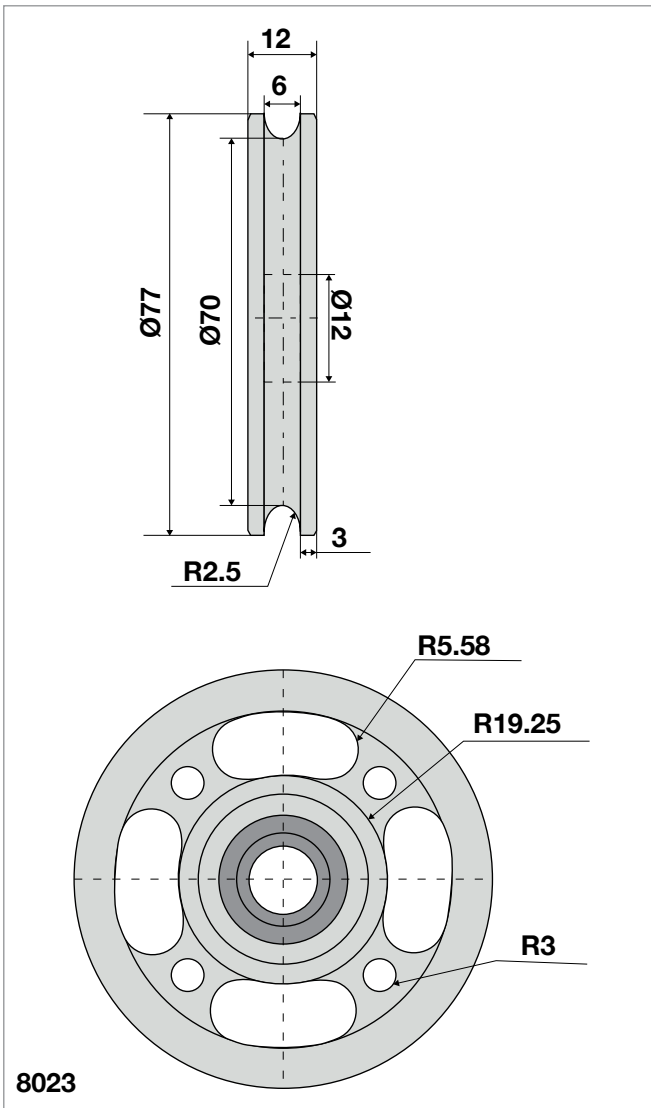

10

Codice / Code	Descrizione
8023	Ruota fune 70 x 5 F12
8092	Ruota fune OTIS

RUOTE STANDARD CON PISTA CONCAVA O PER FUNI
ROLLERS STANDARD WITH CONCAVE TRACK OR ROPE



8003



8004



Y08F



Y09F

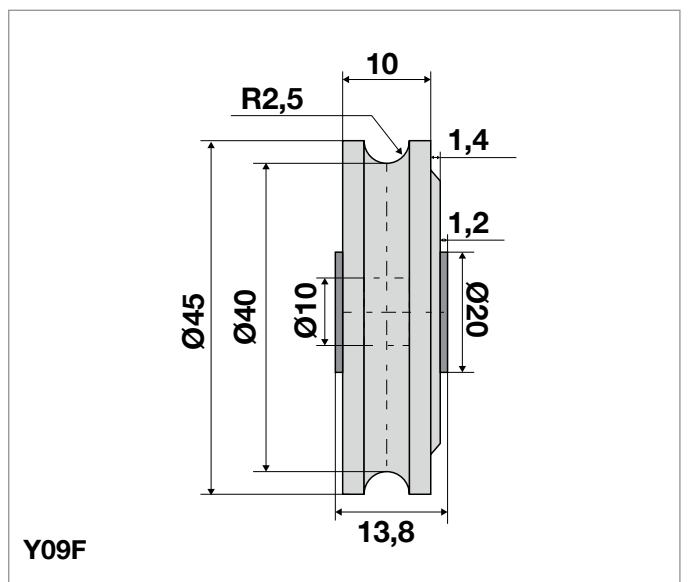
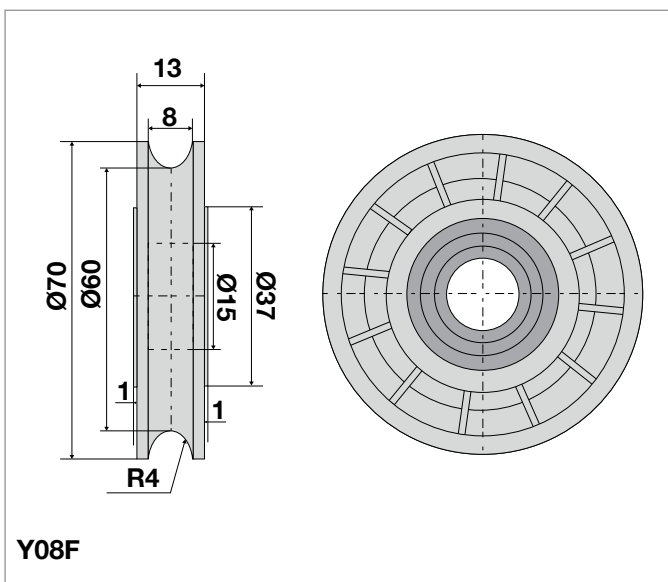
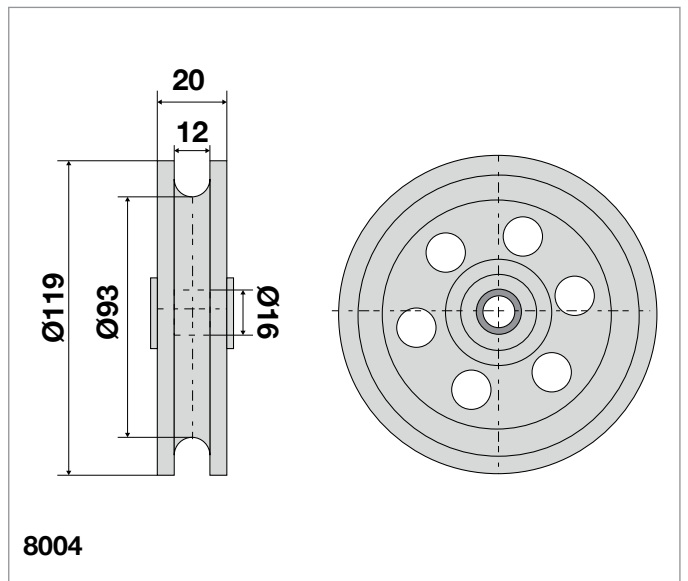
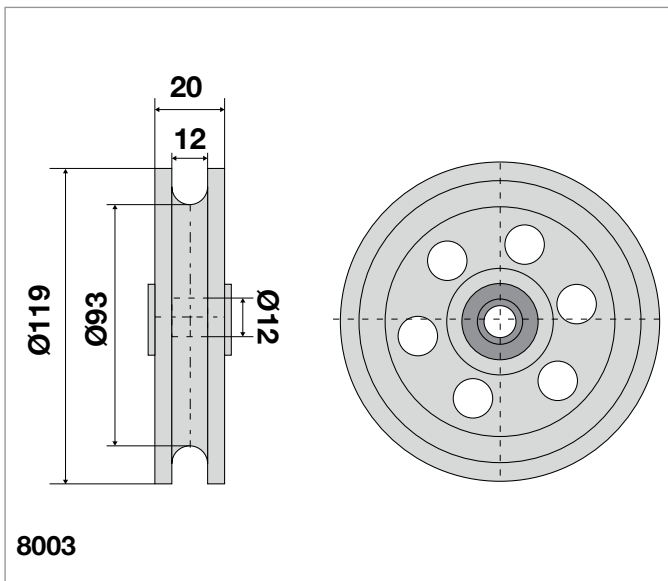

Codice / Code	Descrizione
8003	Ruota D.93 con cuscinetto F12
8004	Ruota D.93 senza cuscinetto con bussole F12
Y08F	Ruota 113 D.60 SABIEM (In esaurimento)
Y09F	Ruota 39.1 D.45 bussola F10

RUOTE STANDARD CON PISTA CONCAVA O PER FUNI ROLLERS STANDARD WITH CONCAVE TRACK OR ROPE

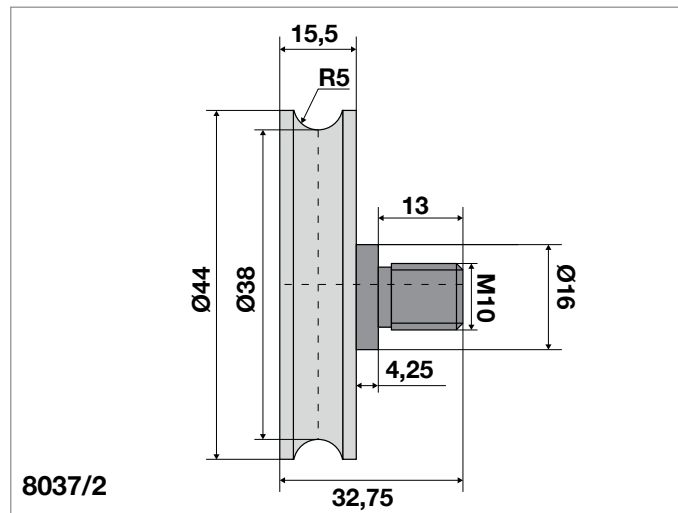
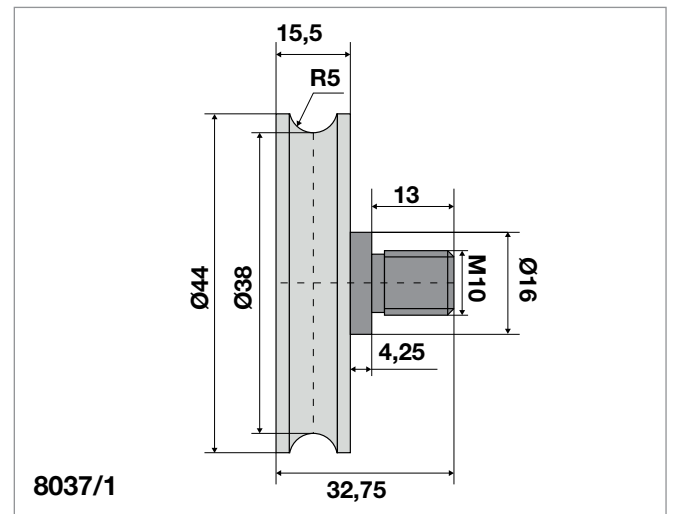
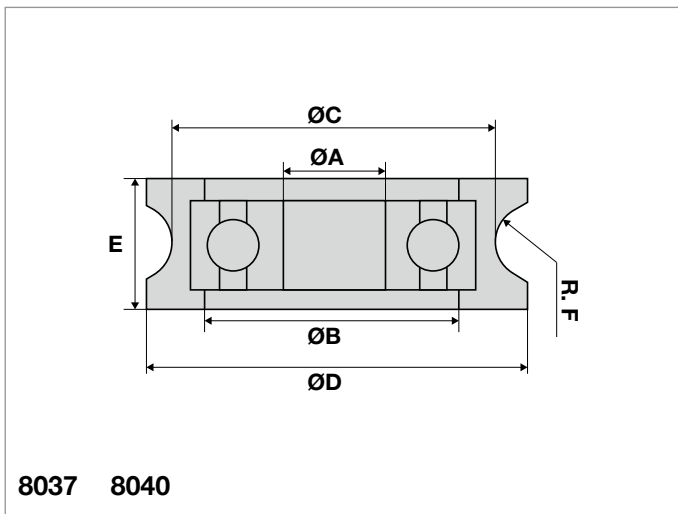

10

Codice / Code	A	B	C	D	E	F	CUSCINO
8037	12	31	38	43	15,5	5	6201 ZZ
8040	12	30	42	51	17,5	7	6201 ZZ

Codice / Code	Descrizione
8037/1	Ruota D.38 R5 con perno centrico M10
8037/2	Ruota D.38 R5 con perno eccentrico M10

RUOTE STANDARD CON PISTA CONCAVA O PER FUNI
ROLLERS STANDARD WITH CONCAVE TRACK OR ROPE

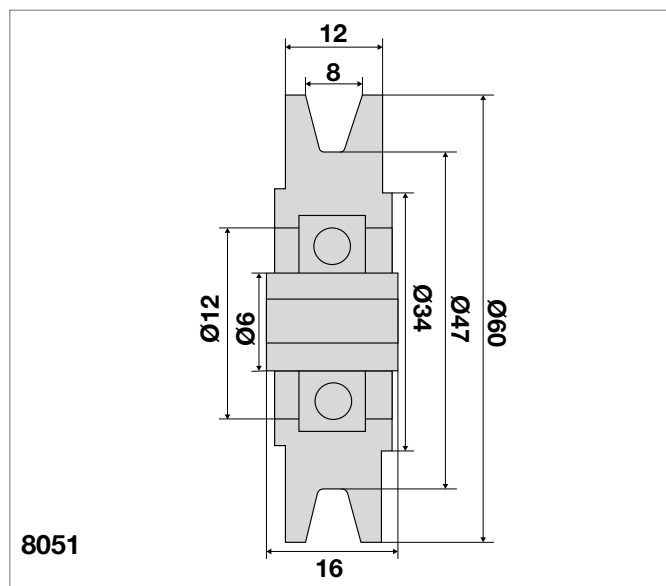
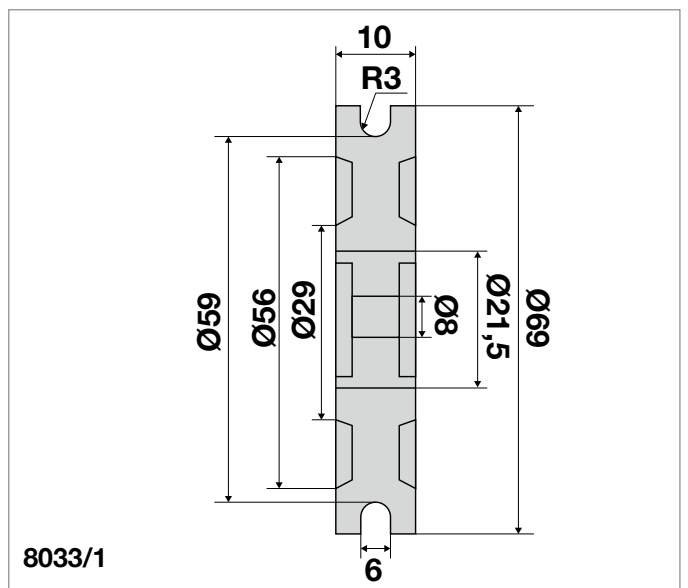
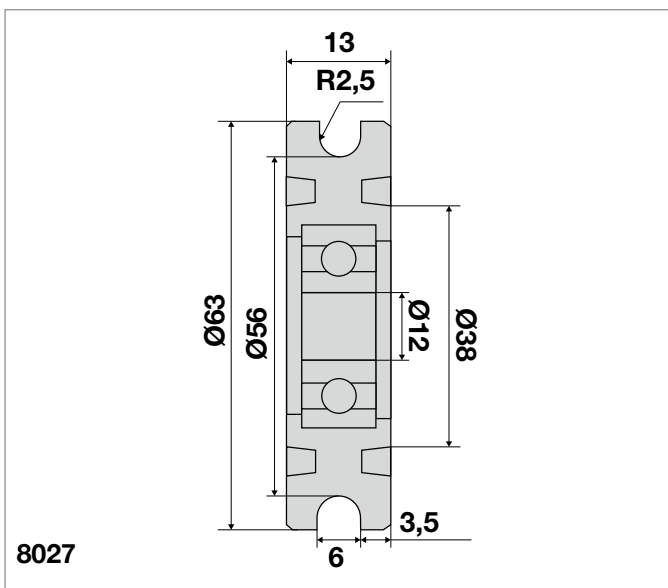
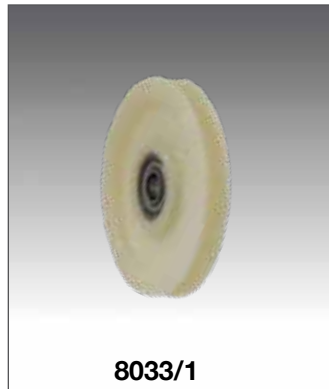
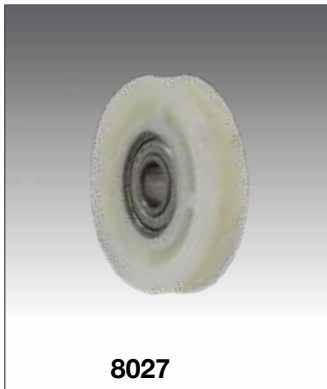

10

Codice / Code	Descrizione
8027	Ruota fune 56 x 5 cuscinetto F12
8033/1	Ruota 59 x R3 cuscinetto F8
8051	Ruota D.60 R2,5 F6.1

**RUOTE FALCONI, FERMATOR E SAFOV CON PISTA CONCAVA O PER FUNI
ROLLERS FALCONI, FERMATOR AND SAFOV WITH CONCAVE TRACK OR ROPE**



8070



8070/1 - 8070/2



8072

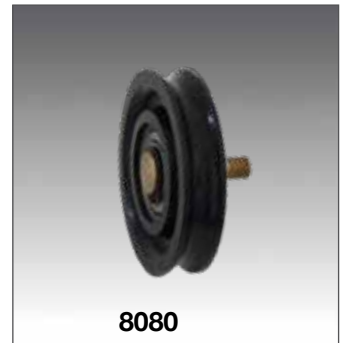

8080

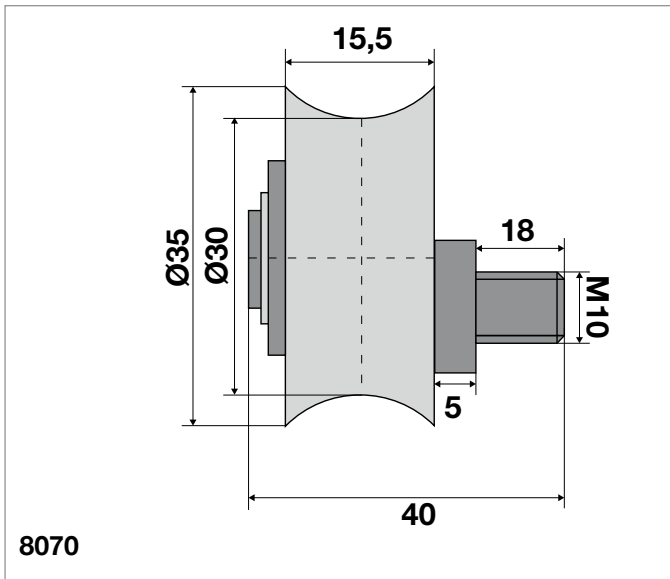

8070

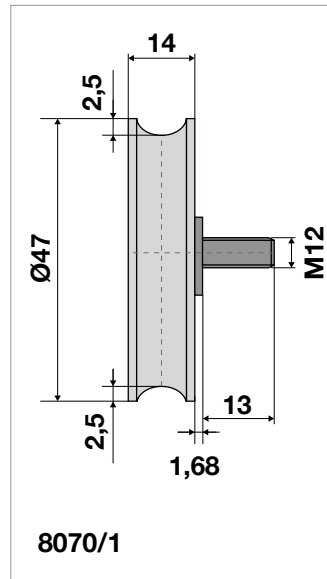

8070/1

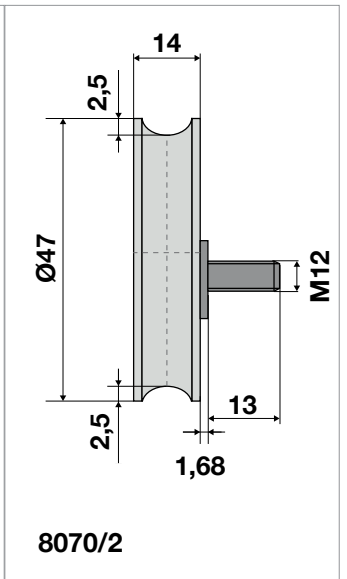

8070/2

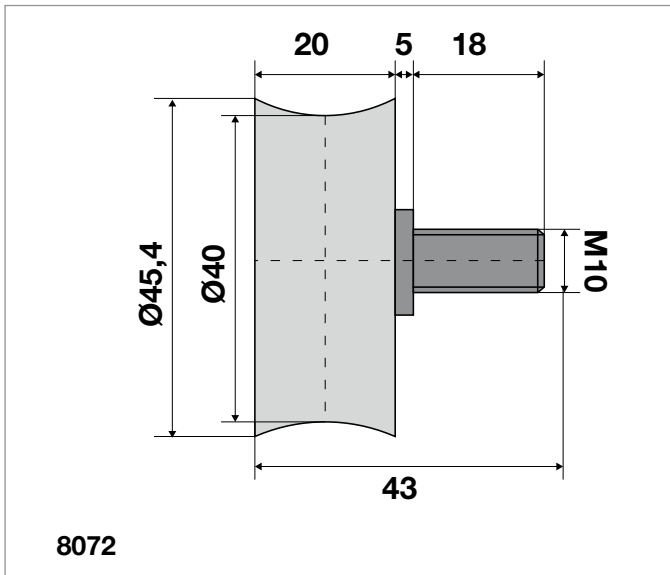

8072

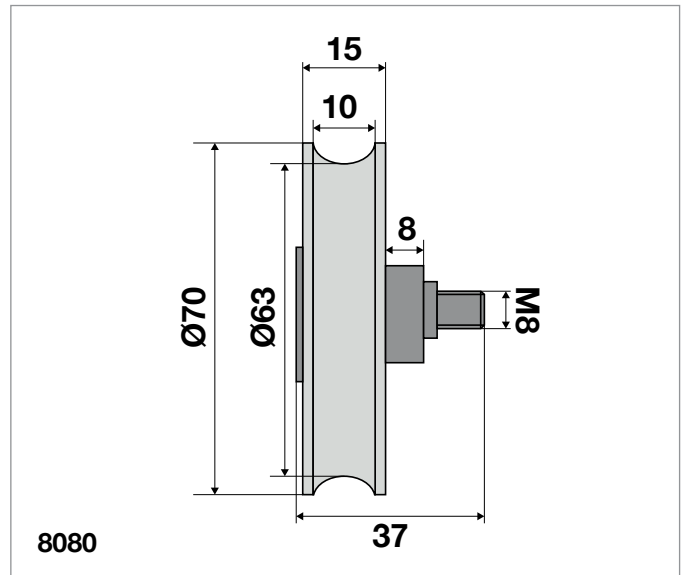

8080

Codice / Code	Descrizione
8070	Rullo registro sospensione operatore SAFOV
8070/1	Ruota gola concava FERMATOR 47 x 14 perno centrico
8070/2	Ruota gola concava FERMATOR 47 x 14 perno eccentrico
8072	Ruota porta semiautomatica sospensione operatore SAFOV
8080	Rotella per operatore di cabina tipo W FALCONI

RUOTE STANDARD E SCHINDLER CON PISTA CONCAVA O PER FUNI
ROLLERS STANDARD AND SCHINDLER WITH CONCAVE TRACK OR ROPE

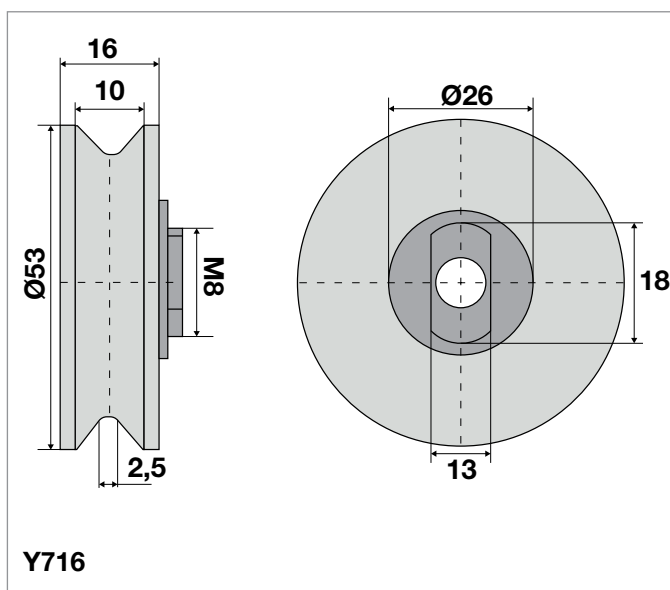
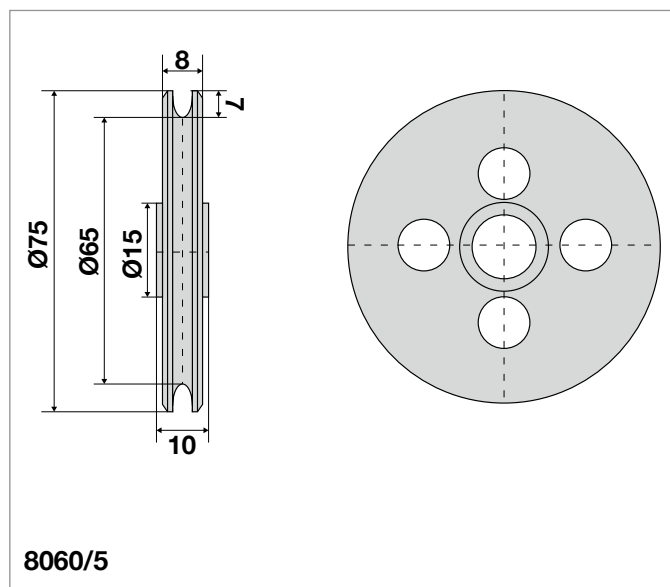
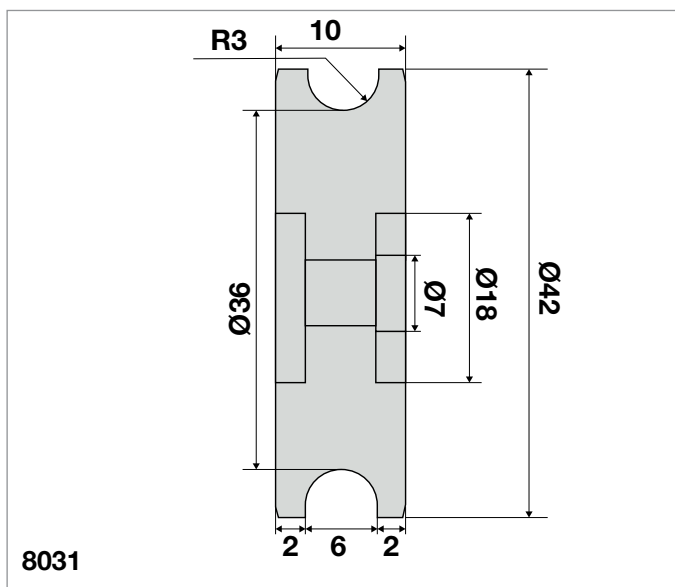
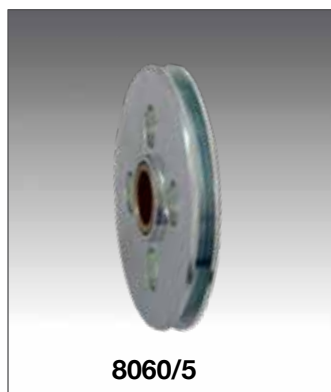

Codice / Code	Descrizione
8031	Ruota 36 x R3 cuscinetto F7
8060/5	Puleggia D.65 a 1 gola abbinamento per porta automatica SCHINDLER
Y716	Ruota 53 x 16 M8 sospensione per porte MONITOR

**RUOTE A RULLO STANDARD, SABIEM, PER OPERATORI E SOSPENSIONI
ROLLERS STANDARD AND SABIEM FOR OPERATOR AND HANGER**

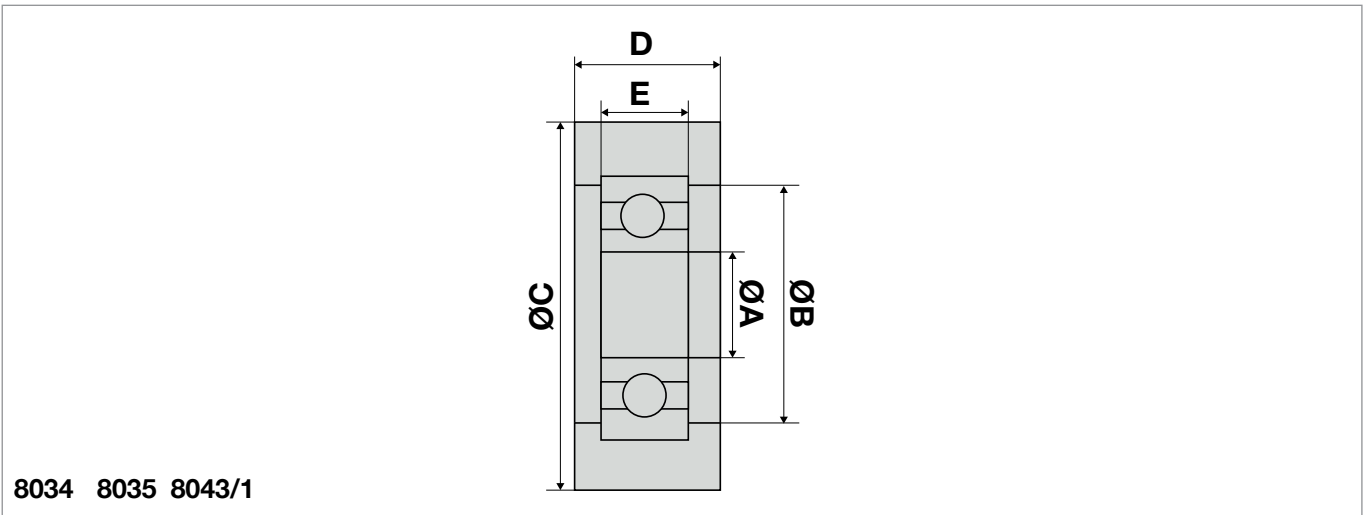
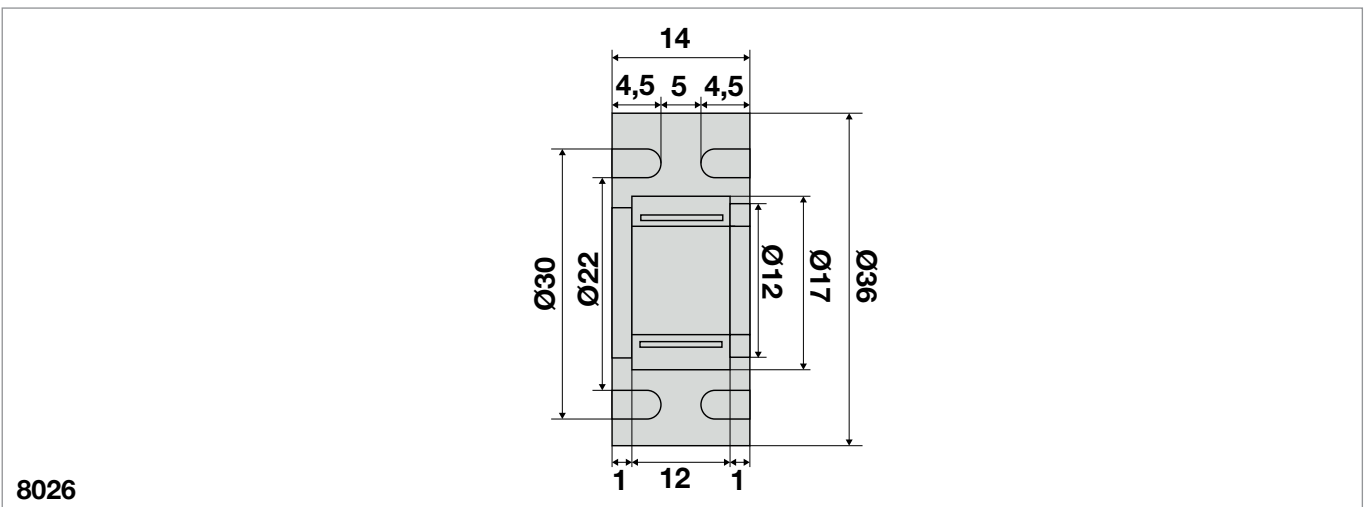

Codice / Code	Descrizione
8026	Ruota 36 x 14 cuscinetto rulli F12

CODICE	A	B	C	D	E	CUSCINO
8034	12	30	40	18	10	6201 2Z
8035	12	30	45	18	10	6201 2Z
8043/1	10	30	45	18	9	6201 2Z

RUOTE A RULLO FALCONI PER OPERATORI E SOSPENSIONI FALCONI ROLLERS FOR OPERATOR AND HANGER

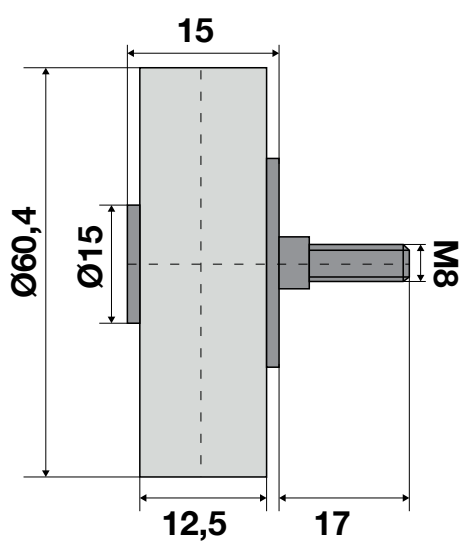

8081

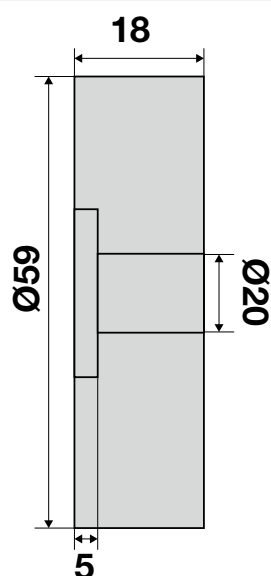

8082

Codice / Code	Descrizione
8081	Ruota per porte "P" operatore FALCONI
8082	Ruota accoppiamento porta automatica tipo "P" FALCONI

RUOTE A RULLO STANDARD OPERATORI E SOSPENSIONI ROLLER STANDARD FOR OPERATION AND HANGER



Y06



Y06/1



Y729



Y730

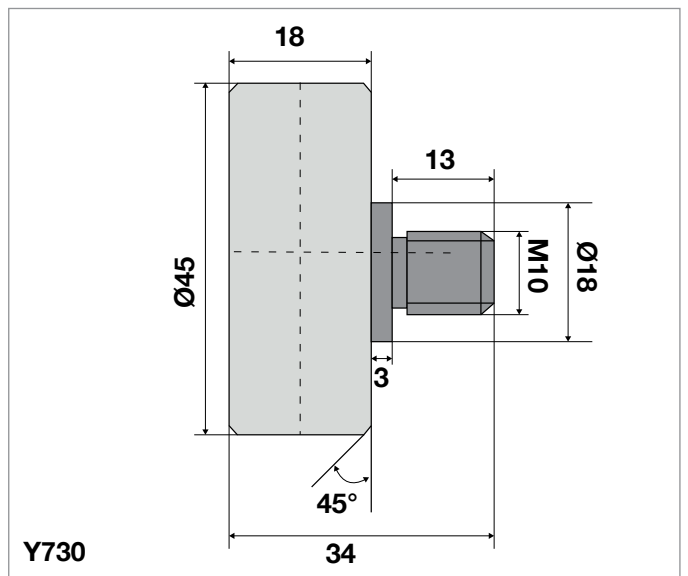
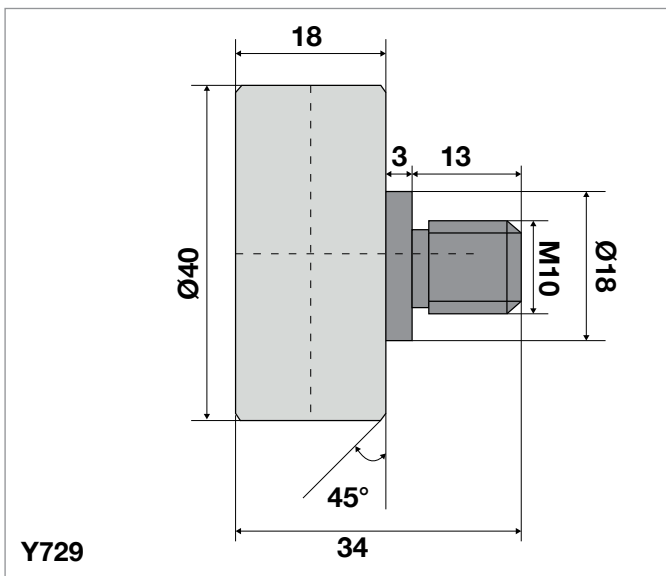
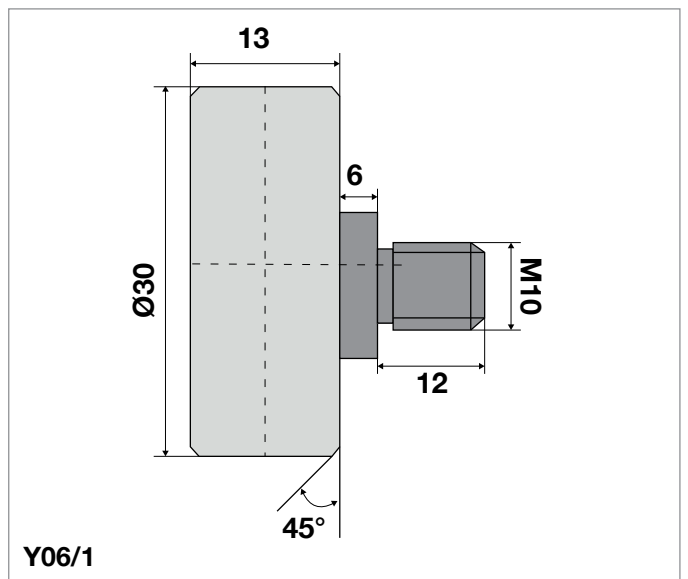
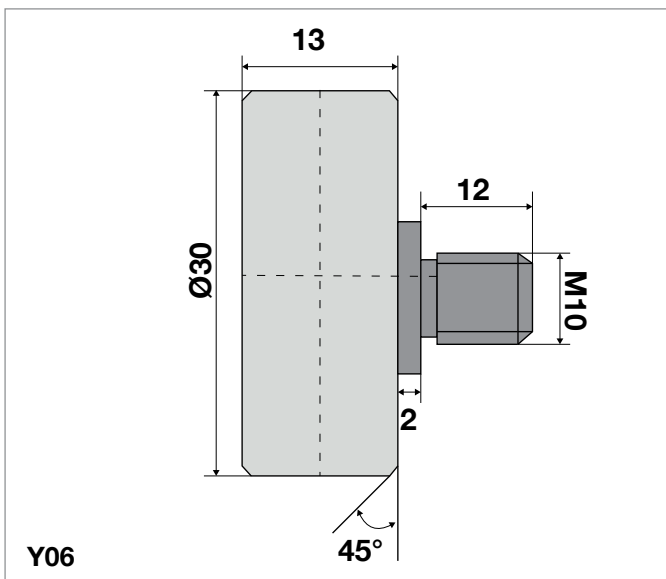

10

Codice / Code	Descrizione
Y06	Ruota D.30 perno eccentrico h.13
Y06/1	Ruota D.30 perno eccentrico h.17
Y729	Ruota 40 x 18 perno eccentrico M10
Y730	Ruota 45 x 18 perno eccentrico M10

RUOTE A RULLO SABIEM PER OPERATORI E SOSPENSIONI
ROLLERS SABIEM FOR OPERATOR AND HANGER

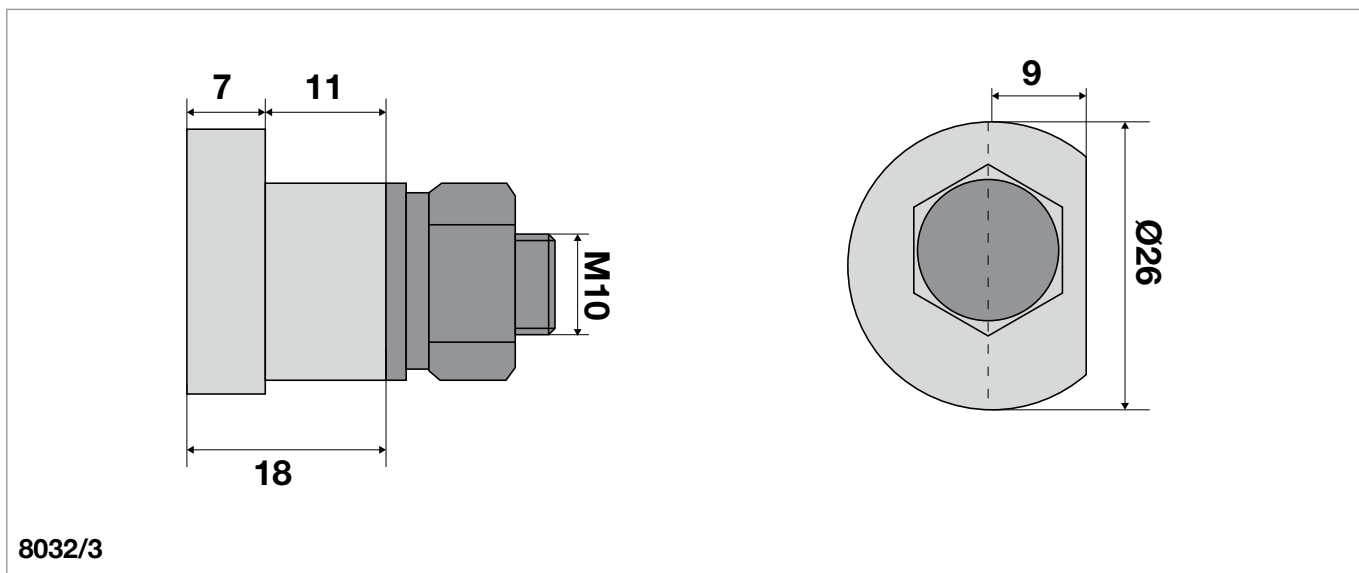
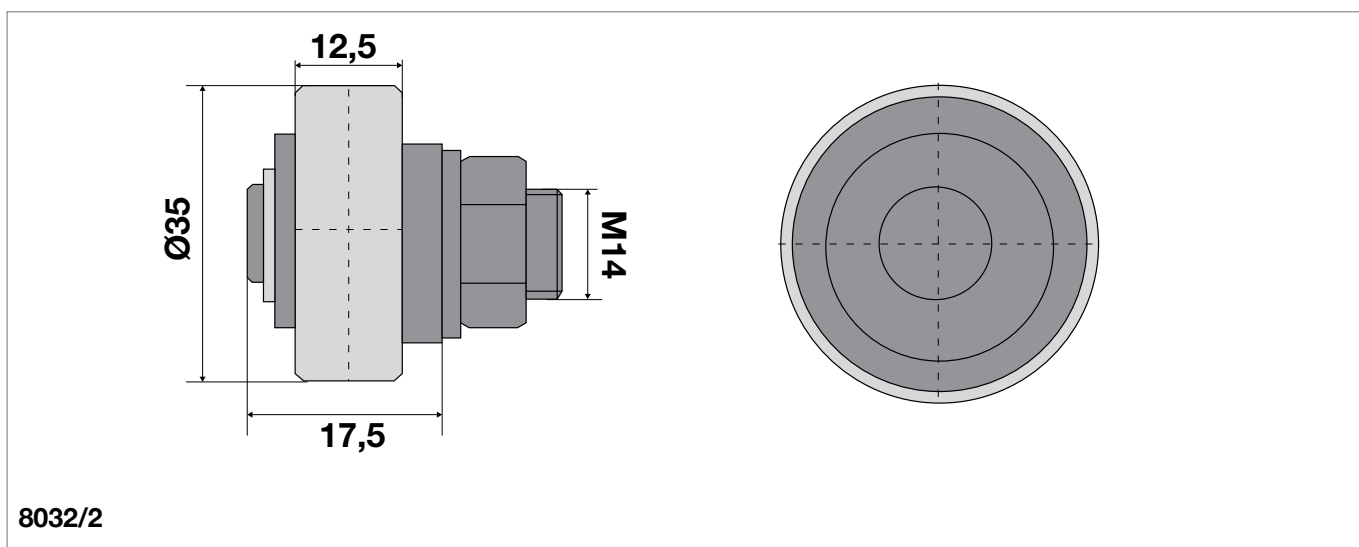

10

Codice / Code	Descrizione
8032/2	Rullo registro eccentrico operatore SABIEM
8032/3	Rullo registro fisso operatore SABIEM

RUOTE A PISTA BOMBATA PER OPERATORI E SOSPENSIONI
ROLLER WITH CURVED TRACK FOR OPERATOR AND HANGER

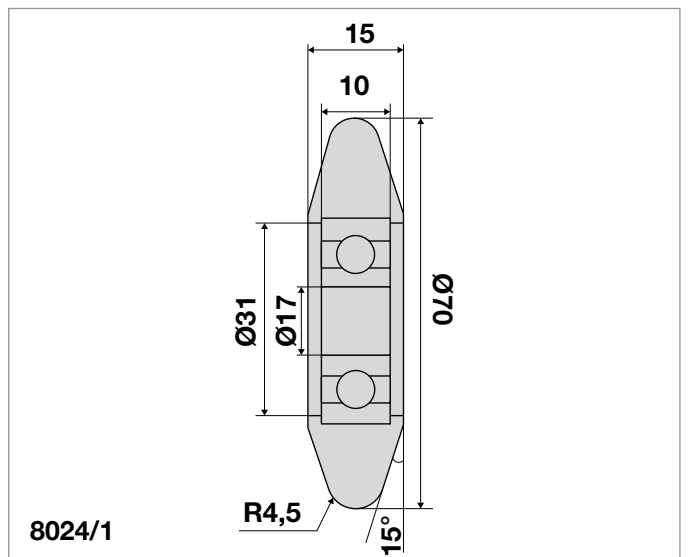
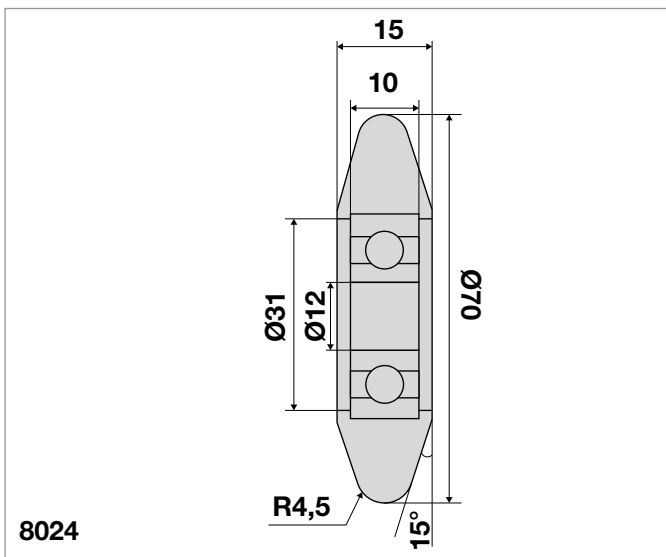
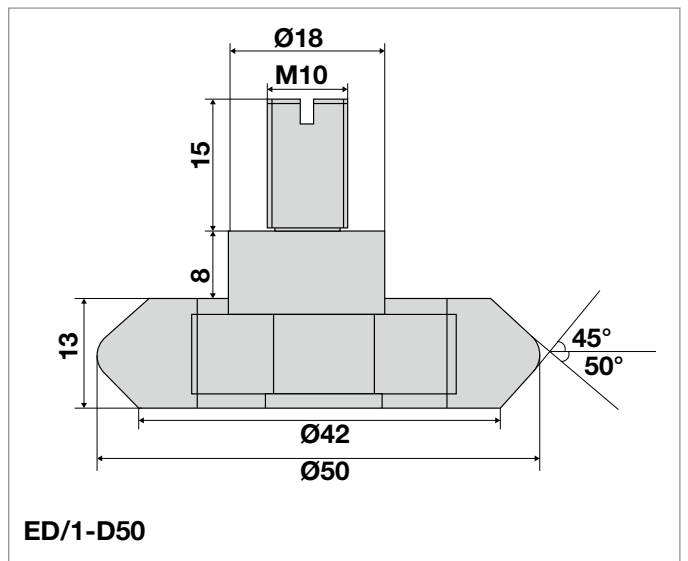
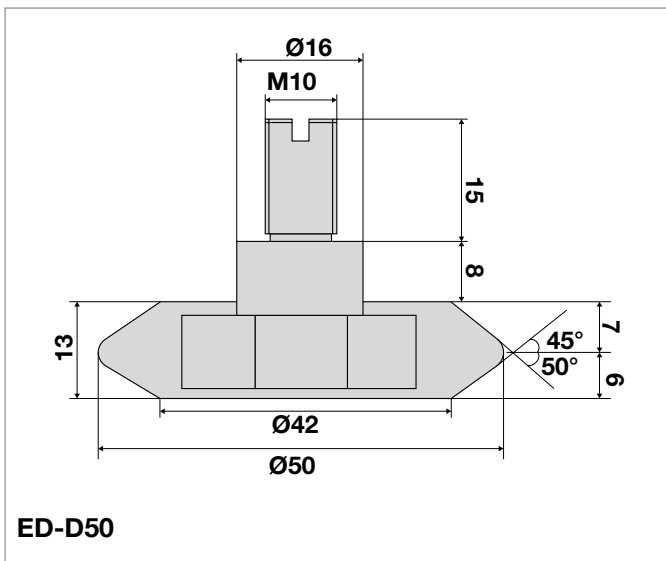

10

Codice / Code	Descrizione
ED-D50	Ruota cuscino tipo 6201 2Z
ED/1-D50	Ruota cuscino tipo 6201 Z perno eccentrico
8024	Ruota D.70 R4,5 cuscinetto F12
8024/1	Ruota AKRON 70 x 15 cuscinetto F17

RUOTE A PISTA BOMBATA PER OPERATORI E SOSPENSIONI SCHINDLER ROLLER WITH CURVED TRACK FOR SCHINDLER OPERATOR AND HANGER

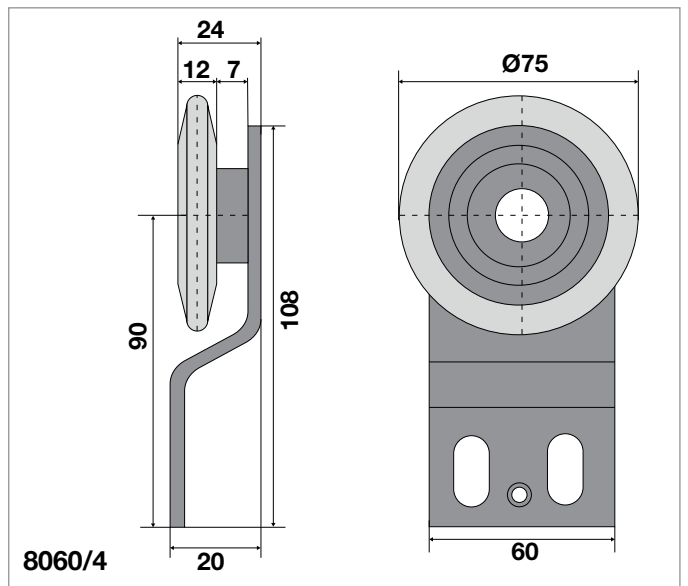
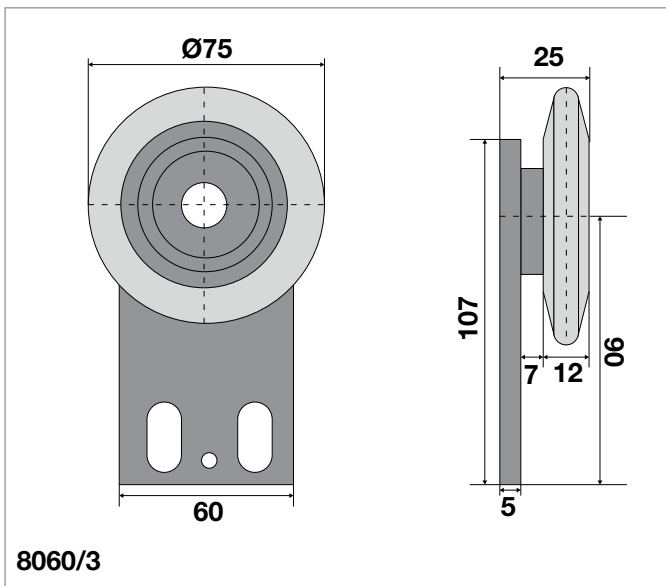
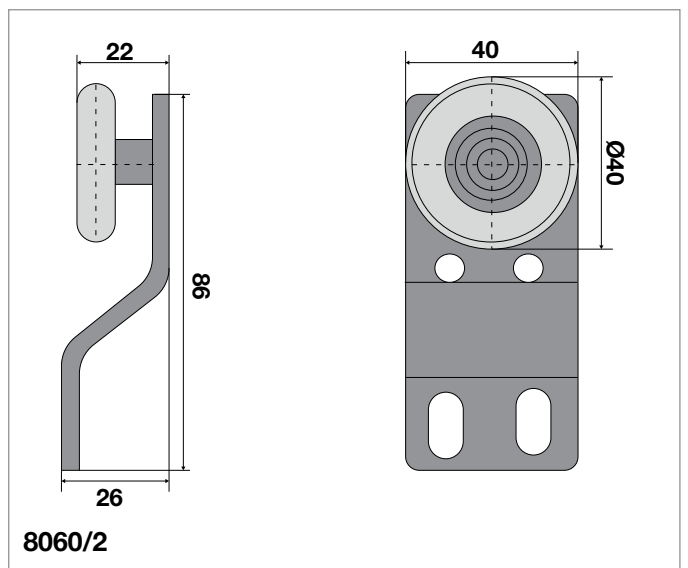
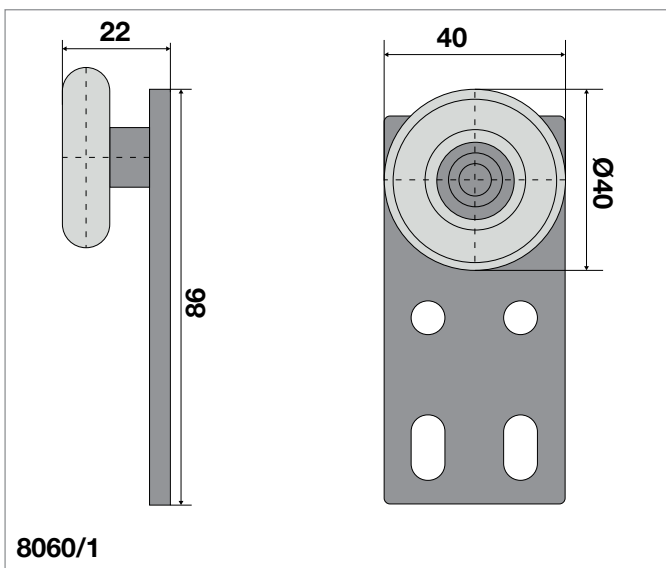

10

Codice / Code	Descrizione
8060/1	Ruota piccola piastra dritta SCHINDLER
8060/2	Ruota piccola piastra sagomata SCHINDLER
8060/3	Ruota + piastra dritta per sospensione SCHINDLER
8060/4	Ruota + piastra sagomata per sospensione SCHINDLER

RUOTE A PISTA BOMBATA FIAM - SCHINDLER
ROLLERS WITH CURVED TRACK FIAM - SCHINDLER

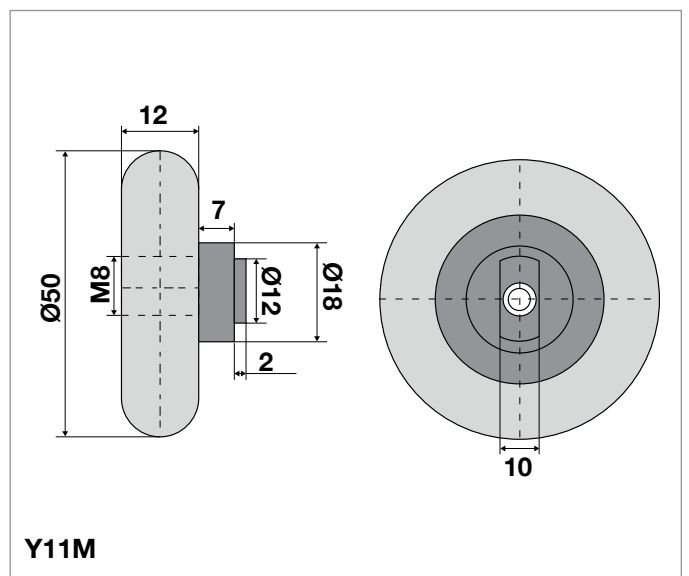
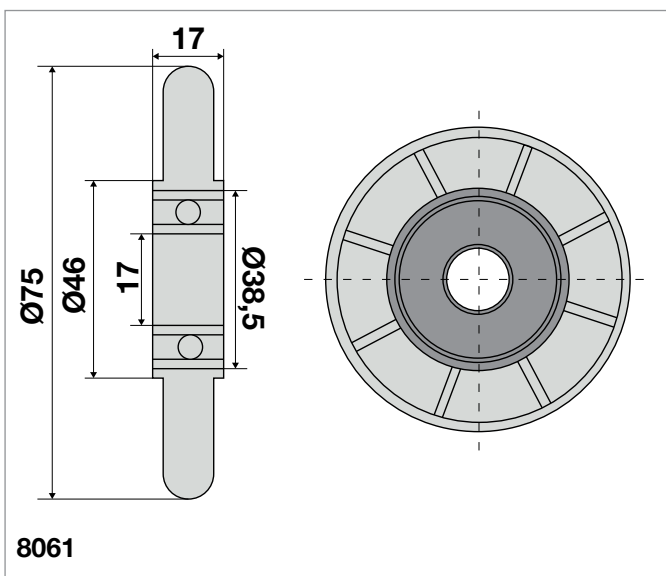
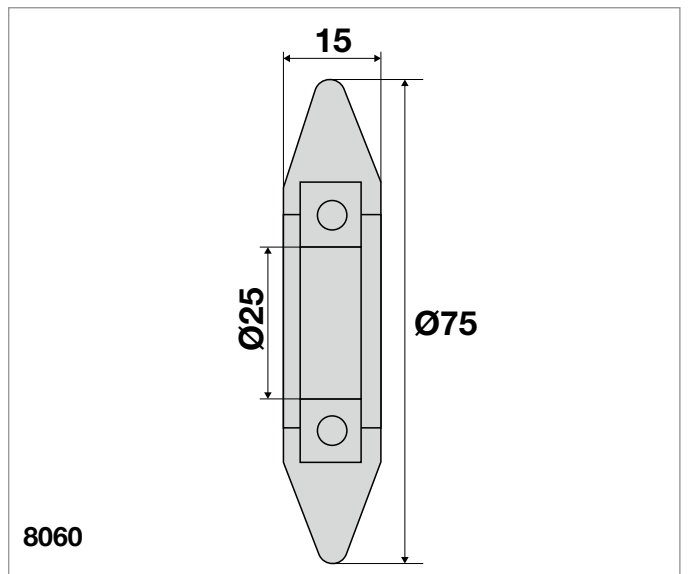
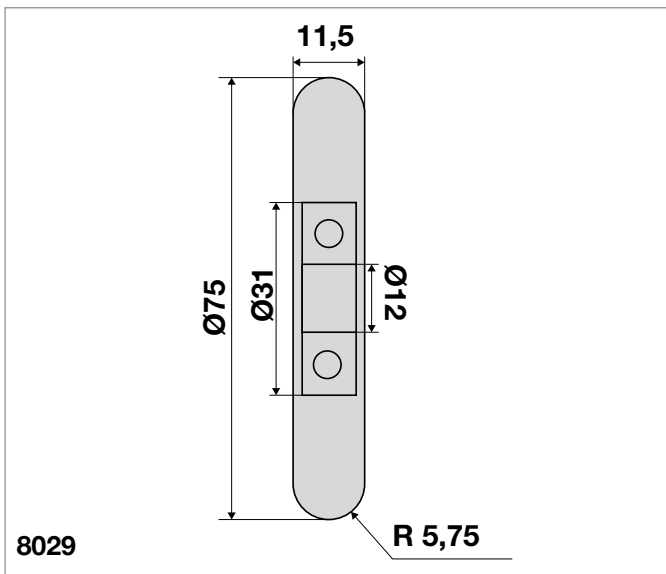

10

Codice / Code	Descrizione
8029	Ruota 75 R5,75 cuscinetto F12
8061	Ruota di sospensione porta automatica A/2PO FIAM
8060	Ruota per porta automatica SCHINDLER
Y11M	Ruota 031 D.50 bussola M8

RULLO PER ARCADE OLEODINAMICHE STANDARD - OTIS HYDRAULIC HOISTWAY ROLLERS STANDARD - OTIS

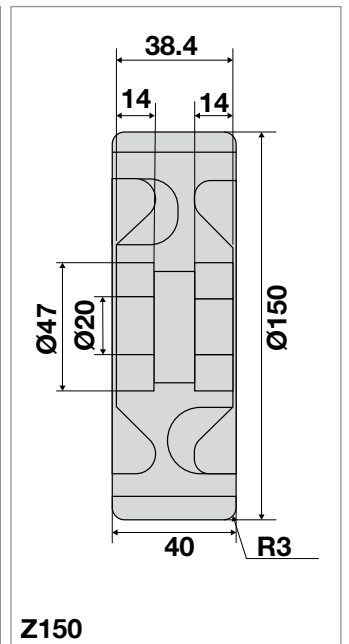
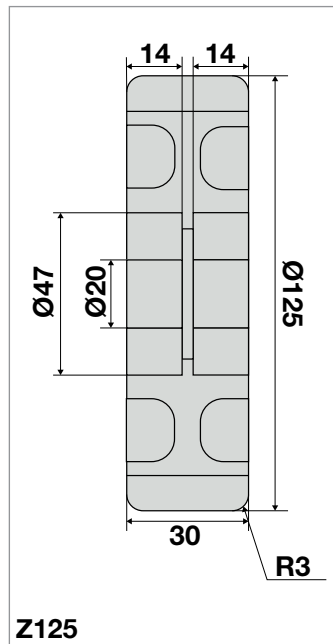
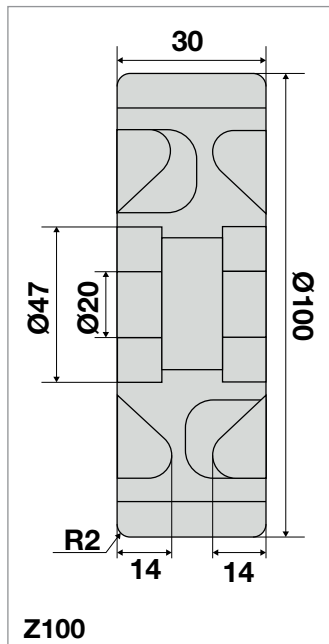
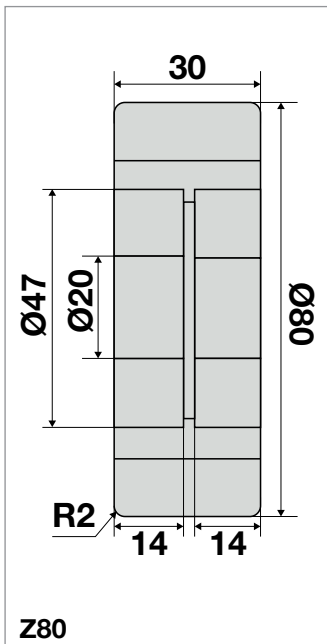
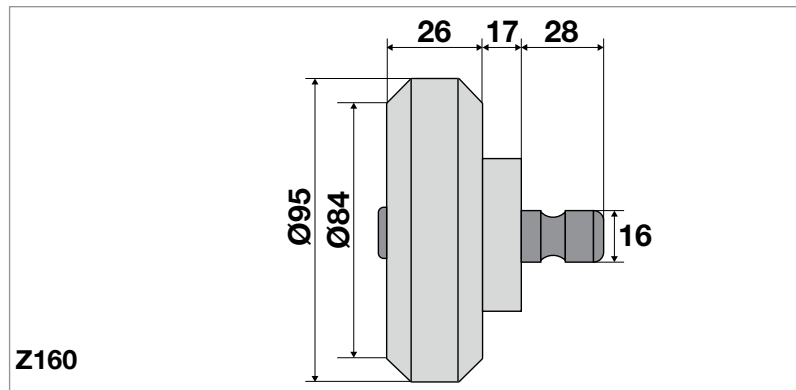

10

Codice / Code	Descrizione
Z80	Rullo per arcate 80 x 30 foro Ø 20 mm AVOLAN
Z100	Rullo per arcate 100 x 30 foro Ø 20 mm AVOLAN
Z125	Rullo per arcate 125 x 30 foro Ø 20 mm AVOLAN
Z150	Rullo per arcate 150 x 40 foro Ø 20 mm AVOLAN
Z160	Rullo per arcate oleodinamiche Ø 95 mm tipo OTIS
Z100/25F15	Rullo per arcate 100 x 25 foro Ø 15 mm
Z100A	Rullo per arcate 100 x 30 foro Ø 25 mm AVOLAN
Z80A	Rullo per arcate 80 x 30 foro Ø 25 mm

**PERNO ECCENTRICO PER PATTINO A RULLO ARCADE OLEODINAMICHE
PIVOT FOR GUIDE SHOE AND HYDRAULIC HOISTWAY ROLLERS**

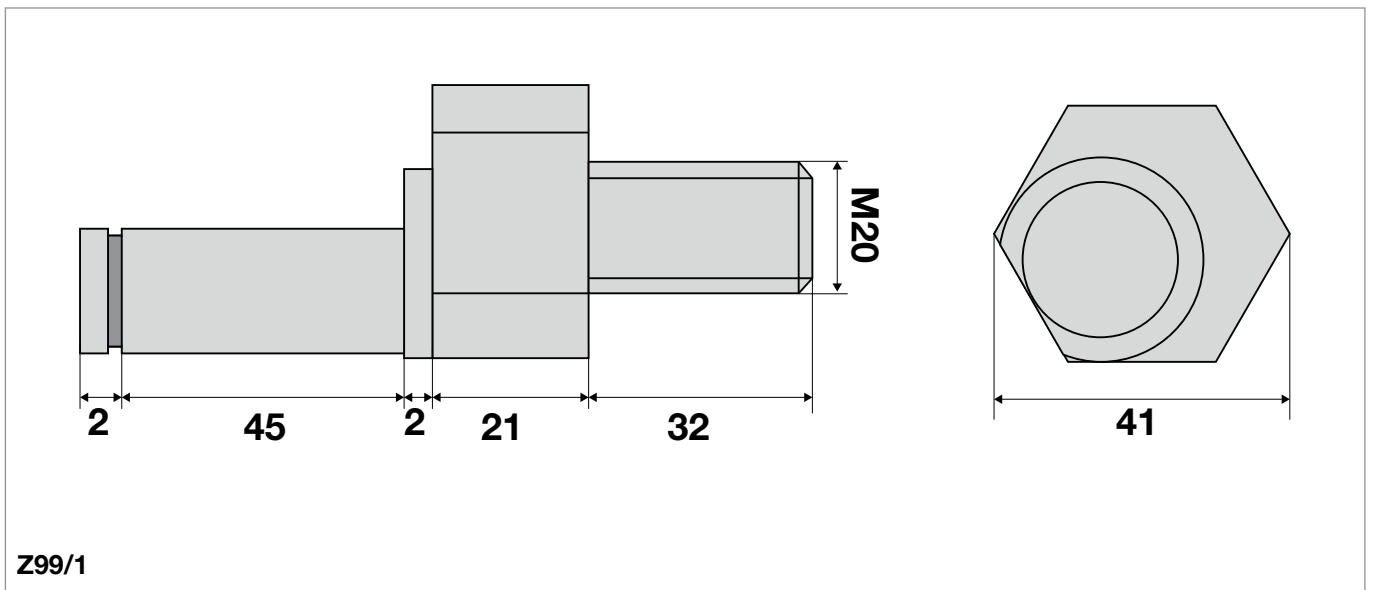
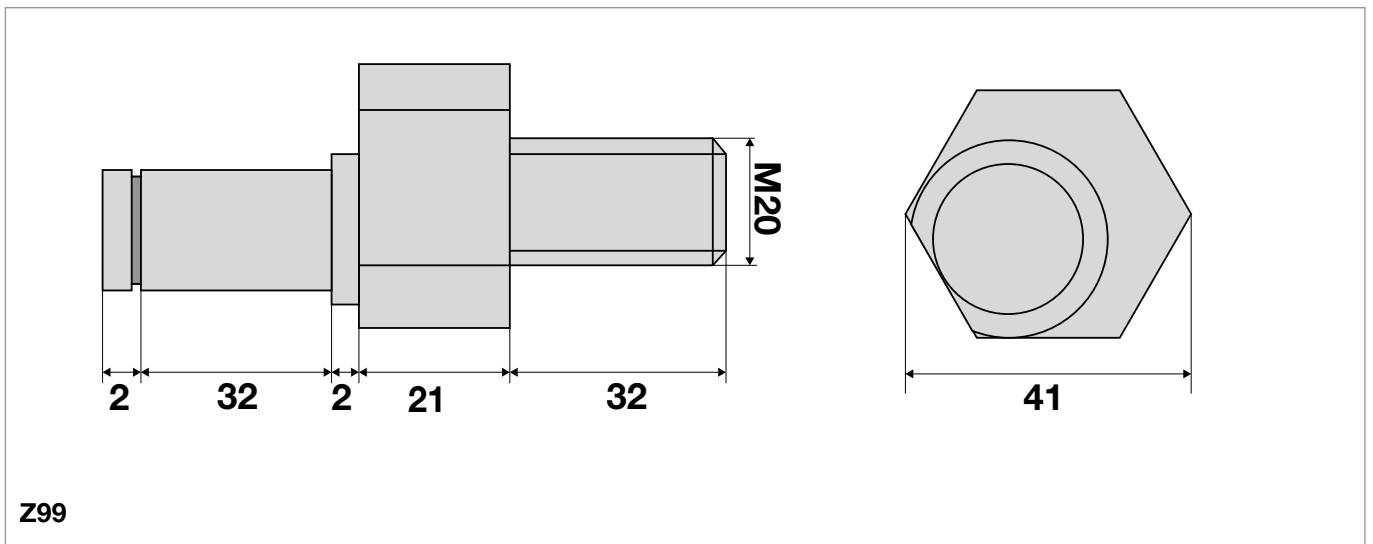

10

Codice / Code	Descrizione
Z99	Perno eccentrico + seeger per rullo spessore 30 mm
Z99/1	Perno eccentrico + seeger per rullo codice Z150

PERNI PER RUOTE OPERATORI E SOSPENSIONI
PIVOT FOR OPERATOR AND HANGER ROLLER

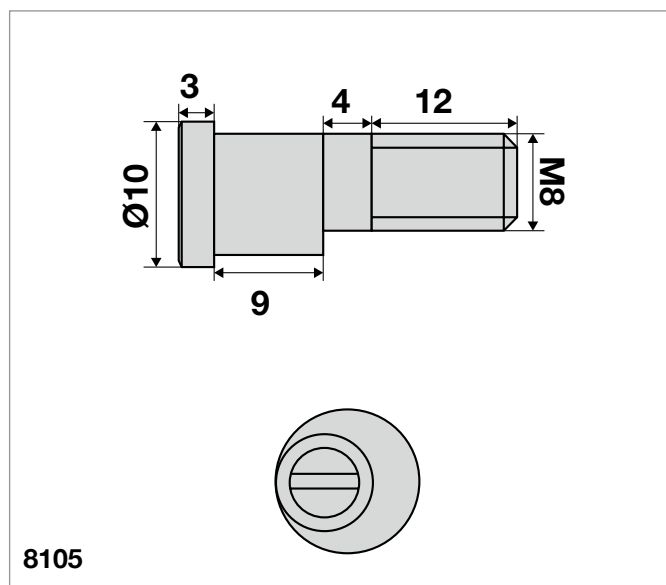
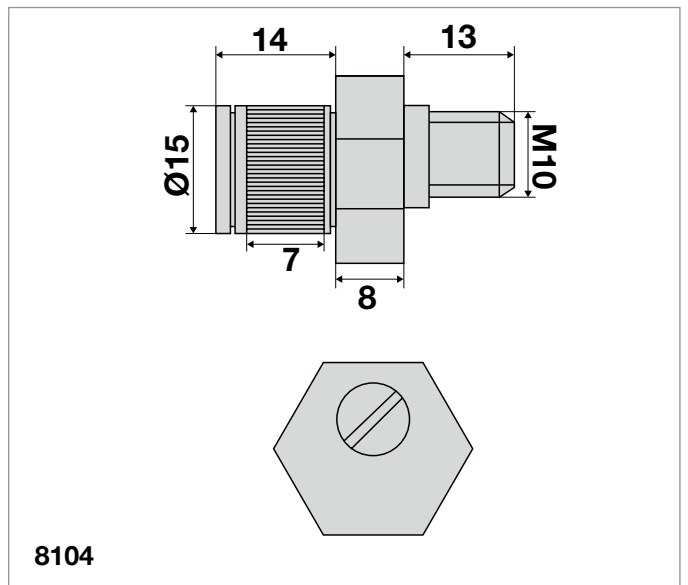
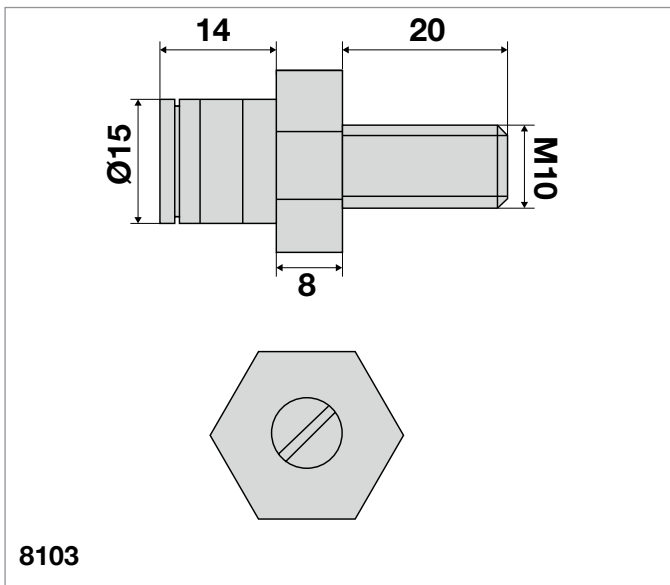

10

Codice / Code	Descrizione
8103	Perno M10 x Ø 15 per pignone Z17 con seeger
8104	Perno M10 x Ø 15 eccentrico CH21
8105	Perno M8 x Ø 10 eccentrico

PERNI PER RUOTE OPERATORI E SOSPENSIONI
PIVOT FOR OPERATOR AND HANGER ROLLER

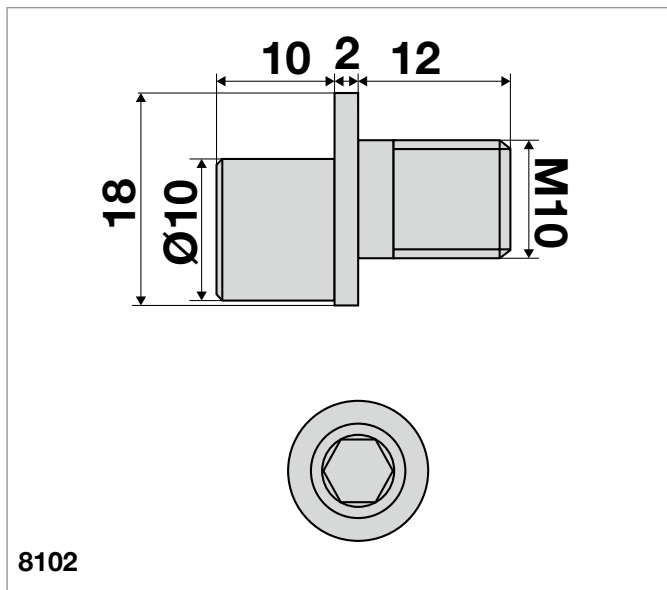
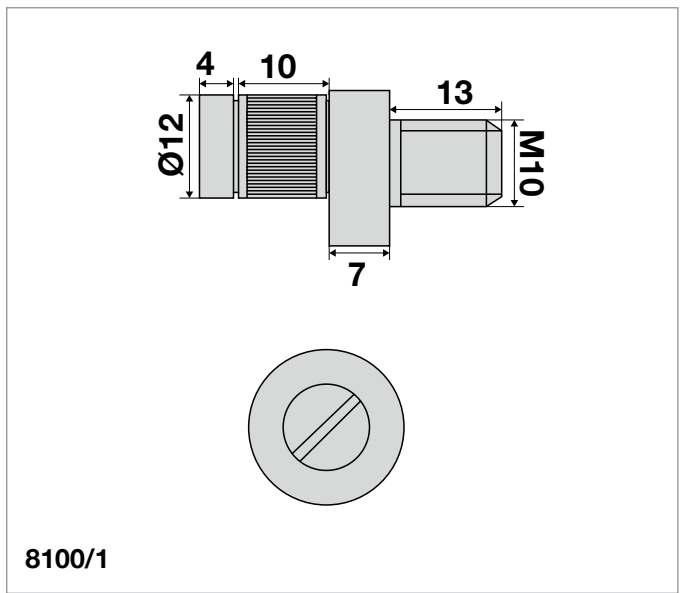
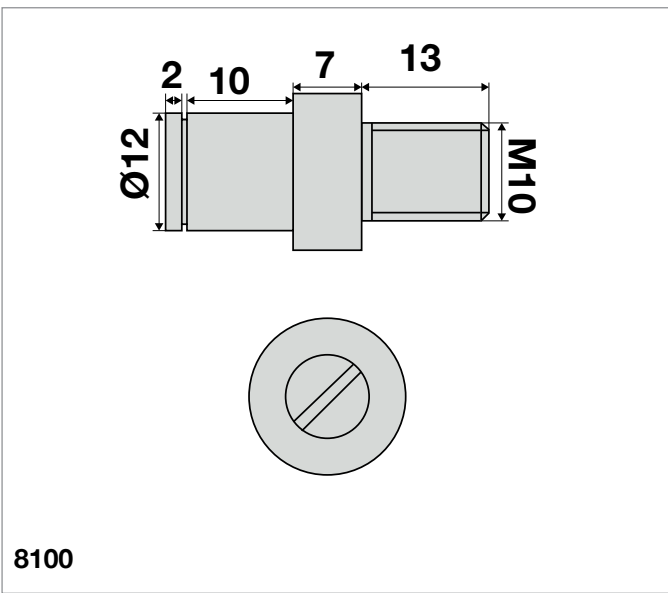

10

Codice / Code	Descrizione
8100	Perno M10 x Ø 12 centrato
8100/1	Perno M10 x Ø 12 eccentrico
8102	Perno M10 x Ø 10 eccentrico

SUPPORTI FIAM
SUPPORT FIAM



Codice / Code	Descrizione
10116/A	Supporto in alluminio gruppo comando operatore tipo S FIAM
10116/B	Supporto in ghisa gruppo di trazione operatore tipo S FIAM

CINGHIE PIATTE RIGATE E TRAPEZOIDALI SCHINDLER, BASSETTI, FIAM, SAFOV FLAT STRIPED AND TRAPEZOIDAL BELTS FOR SCHINDLER, BASSETTI, FIAM, SAFOV

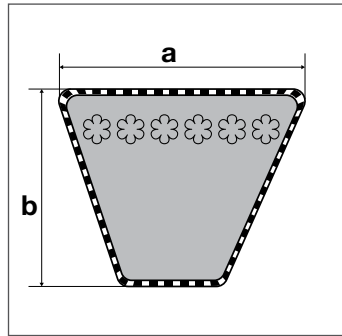
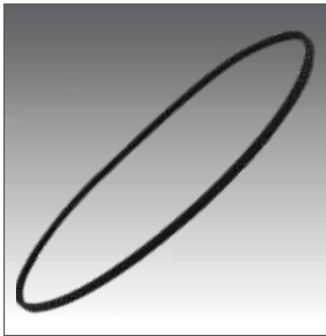

Sezioni	a (mm)	b (mm)
XPZ	10	8
XPA	13	10
XPB	16	13
XPC	22	18

Cinghie Trapezoidali

Per cinghie su richiesta comunicare la Mis "A" e "B" lo sviluppo (lunghezza) e se trapezoidale liscia o dentata e sigle sopra riportate sulla cinghia

Codice / Code	Descrizione
1009/3	Cinghia trapezoidale PHG Z55 FIAM
1009/7	Cinghia automatismo S/2PO AP.500/550 S/2PT-4PT AP.1000/1100 FIAM
1009/8	Cinghia automatismo S/2PO AP.600/1500 S2PT-4PT AP.1200/2500 FIAM
1009/9	Cinghia trapezoidale Z30.25 operatore BASSETTI
1009/10	Cinghia trapezoidale PHG Z40
1009/11	Cinghia trapezoidale PHG A49
1009/12	Cinghia trapezoidale PHG A60
1009/13	Cinghia trapezoidale PHG Z40.5
1009/14	Cinghia trapezoidale PHG A65
1009/15	Cinghia trapezoidale Z42 10x1070 operatore SAFOV
1009/16	Cinghia A44

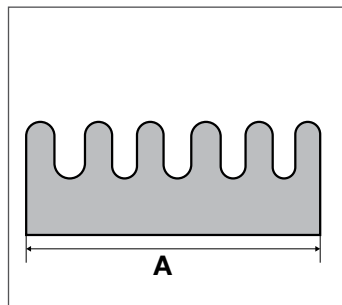

Cinghie piatte rigate

Per cinghie su richiesta comunicare larghezza "A" quantità nervature e sviluppo.

Codice / Code	Descrizione
1009/1	Cinghia 400J PJ1016 10 nervature operatore SCHINDLER
1009/2	Cinghia 400J 1016J 4 nervature operatore SCHINDLER
1009/4	Cinghia 1016J 3 nervature
1009/5	Cinghia 1016J 5 nervature
1009/6	Cinghia 180J 6 nervature automatismo B/2PT FIAM
1009/17	Cinghia PJ711 280J 8 nervature
1003/15	Cinghia benda Schindler

CINGHIE TONDE ROUND BELTS

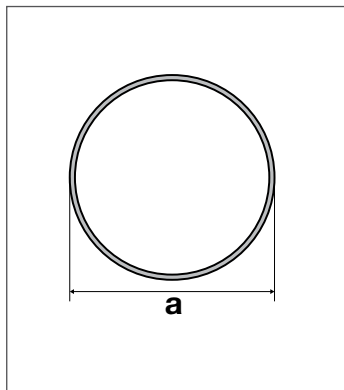
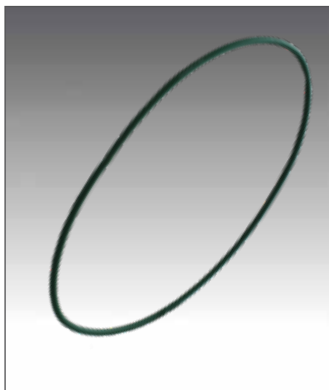

Tonde

Codice / Code	Descrizione
1009/1T	Cinghia per encoder takimetrico kone Ø 4,18
1009/2T	Cinghia operatore FERMATOR porta a soffietto
1009/3T	Cinghia operatore FERMATOR telescopica

Per cinghie su richiesta comunicare diametro e sviluppo

CINGHIE DENTATE TOOTHED BELTS

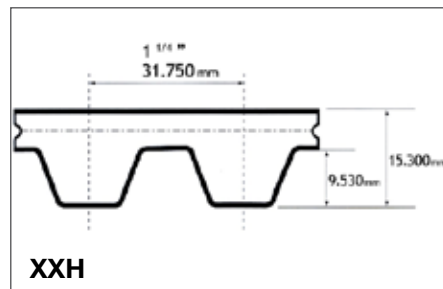
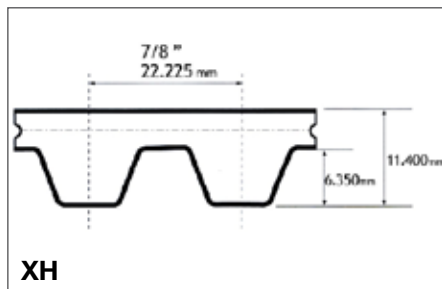
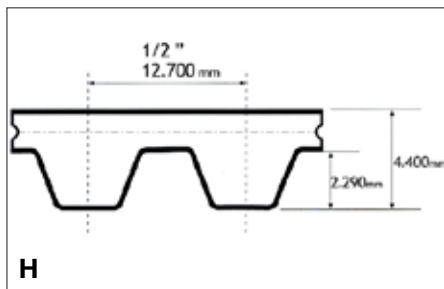
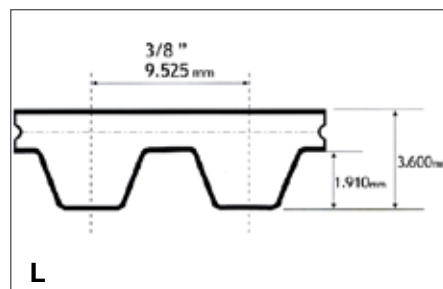
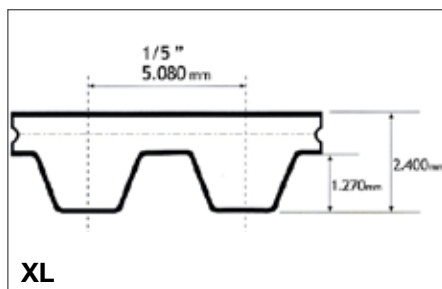
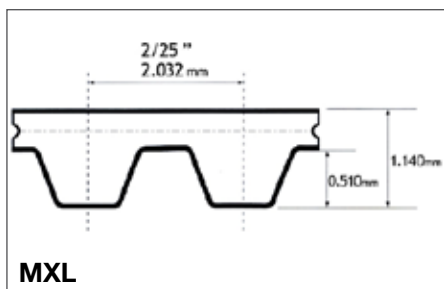
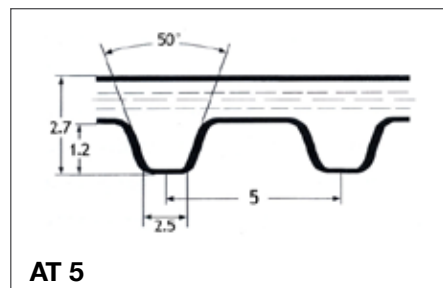
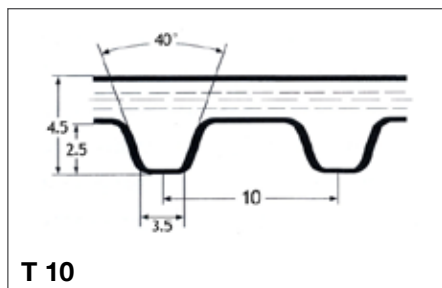
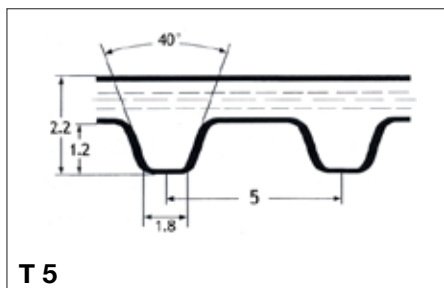
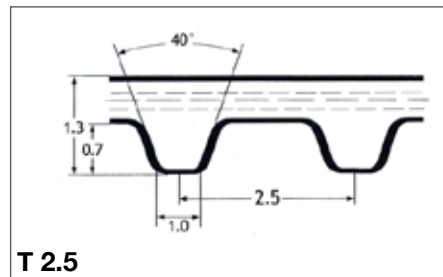

Comunicare passo larghezza e sviluppo

Codice / Code	Descrizione
T2.5	Cinghie dentate tipo T passo 2.5 mm
T5	Cinghie dentate tipo T passo 5 mm
T10	Cinghie dentate tipo T passo 10 mm
AT5	Cinghie dentate tipo AT passo 5 mm
MXL	Cinghie dentate in pollici passo MXL
XL	Cinghie dentate in pollici passo XL
L	Cinghie dentate in pollici passo L
H	Cinghie dentate in pollici passo H
XH	Cinghie dentate in pollici passo XH
XXH	Cinghie dentate in pollici passo XXH

NOTE

PIGNONI - INGRANAGGI OPERATORI

PINIONS - OPERATOR GEARS

Albero-corona in bronzo per motoriduttore tipo MR041 FIAM	11.6
<i>Driving shaft in bronze for motor reducer type MR041 FIAM</i>	
Ingranaggio doppio per operatore OTIS	11.7
<i>Plastic spur gear OTIS</i>	
Ingranaggio in plastica motoriduttore tipo MR041 FIAM	11.6
<i>Plastic gear in motor reducer type MR041 FIAM</i>	
Ingranaggio operatore SABIEM	11.7
<i>Gear SABIEM operator</i>	
Mezza ruota OTIS	11.7
<i>Drive sprocket OTIS</i>	
Pignoni operatori FIAM	11.4
<i>Pinion for operator FIAM</i>	
Pignone rinvio operatore FIAM per porte automatiche tipo S	11.5
<i>Pinion chain return sprocket FIAM operator for automatic door type S</i>	
Pignoni Z15 - Z17 - Z20 - Z21	11.2 - 11.3
<i>Pinions Z15 - Z17 - Z20 - Z21</i>	
Puleggia con pignone FIAM tipo S, S/2PT, S/4PT	11.5
<i>Pulley with pinion for FIAM operator type S, S/2PT, S/4PT</i>	

Note: I componenti sul catalogo con riportata una specifica marca di ascensore sono utilizzati abitualmente solo da questa marca. I particolari senza marca sono utilizzati da più marche di ascensori.

Note: The components in the catalogue with a specific lift brand are usually used only by the brand. Unbranded parts are used by multiple lift brands.

PIGNONI PINION

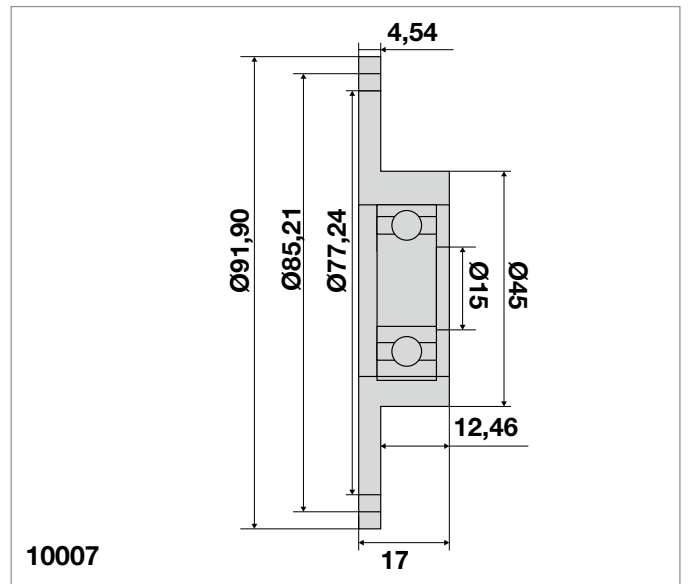
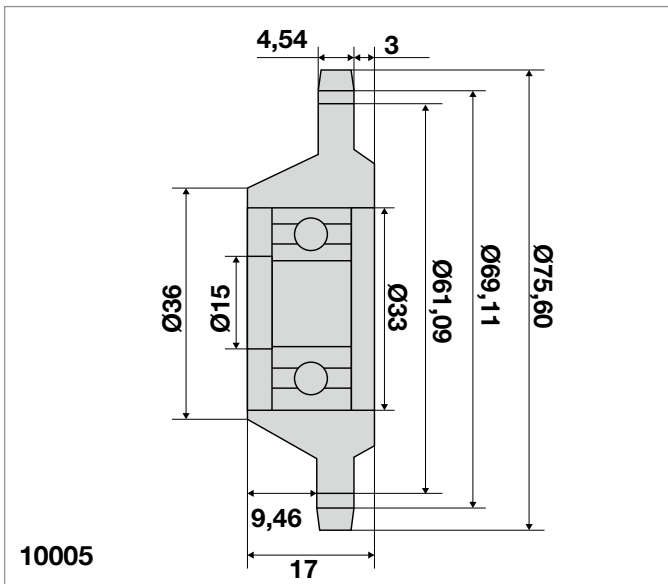
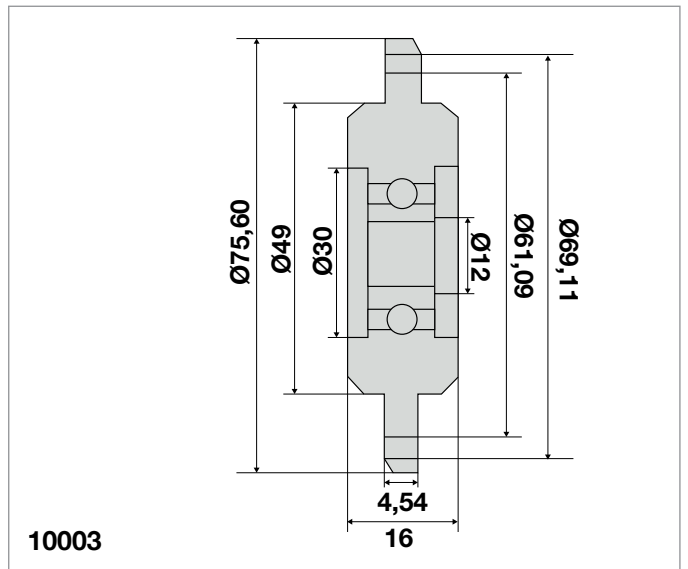
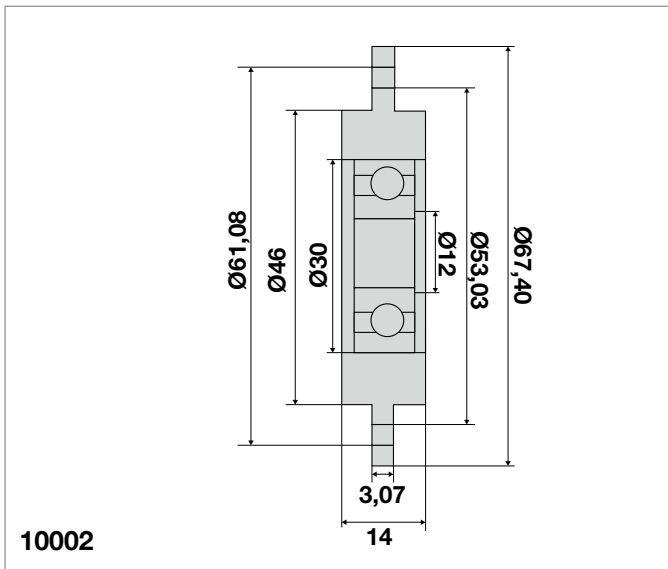

Codice / Code	Descrizione
10002	Pignone Z15 cuscinetto F12
10003	Pignone Z17 cuscinetto F12
10005	Pignone Z17 cuscinetto F15
10007	Pignone Z21 cuscinetto F15

PIGNONI PINION



10004



10008



10112

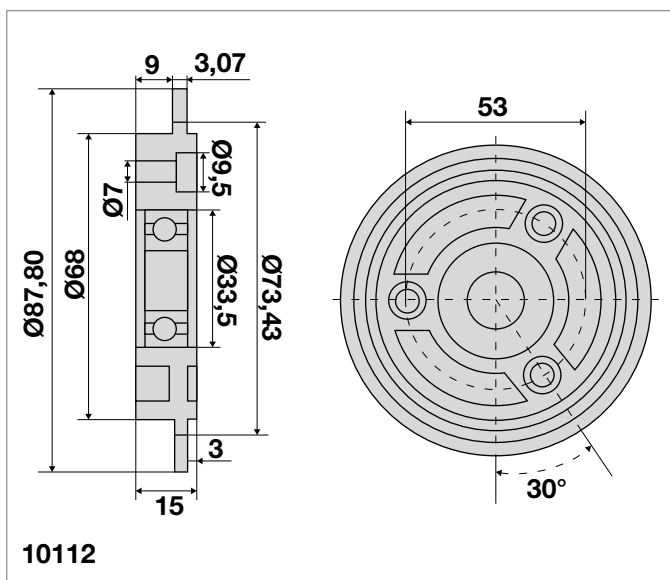
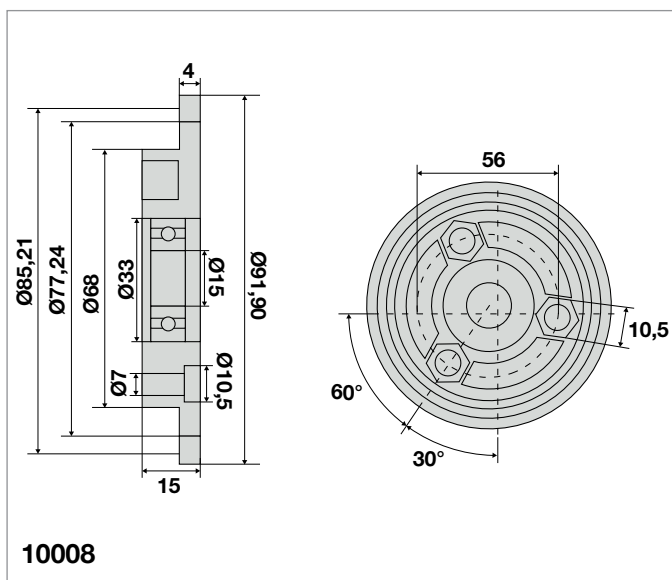
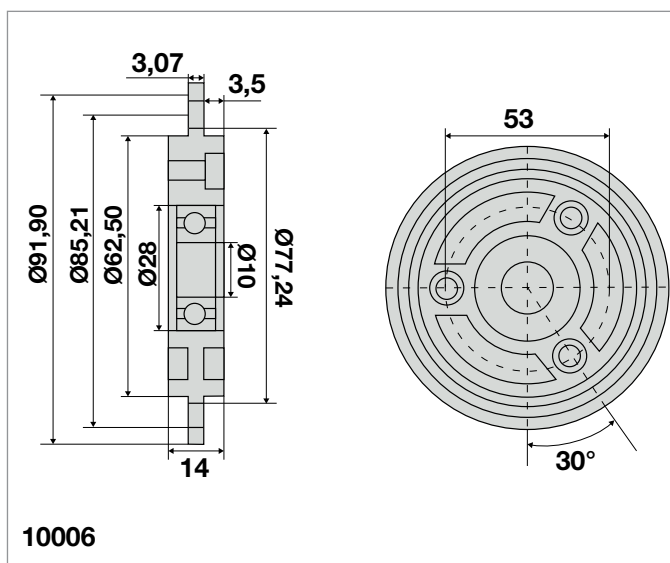
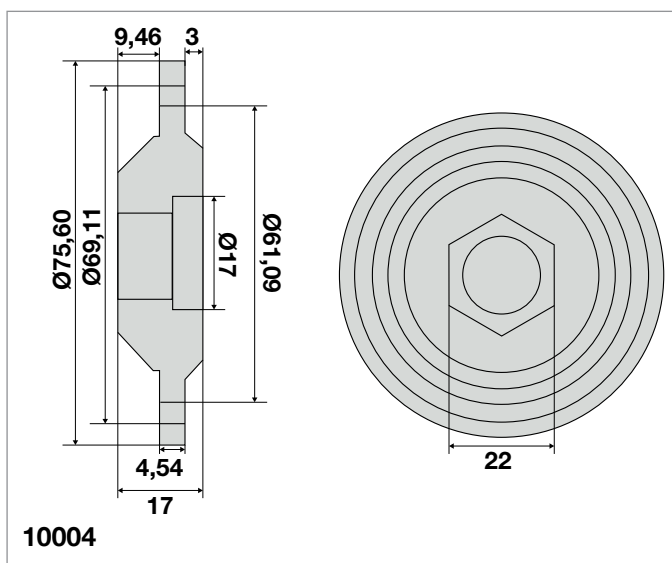

Codice / Code	Descrizione
10004	Pignone Z17 con esagono
10006	Pignone Z21 cuscinetto F10
10008	Pignone Z21 cuscinetto F15
10112	Pignone Z20 cuscinetto F15

PIGNONI OPERATORI FIAM PINION FOR FIAM OPERATOR

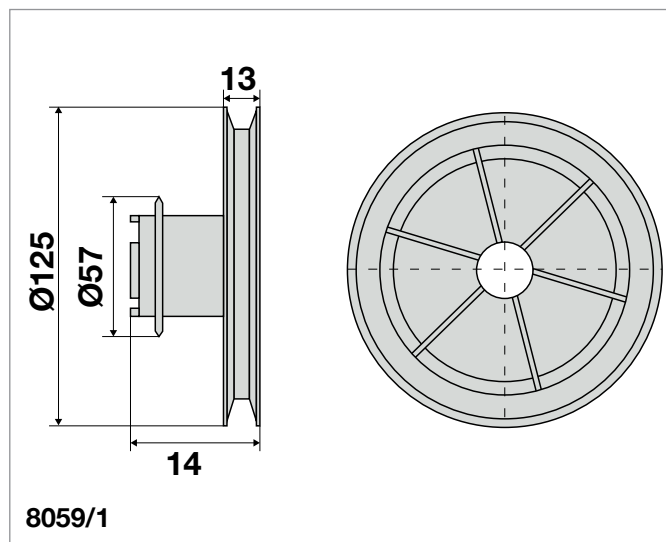
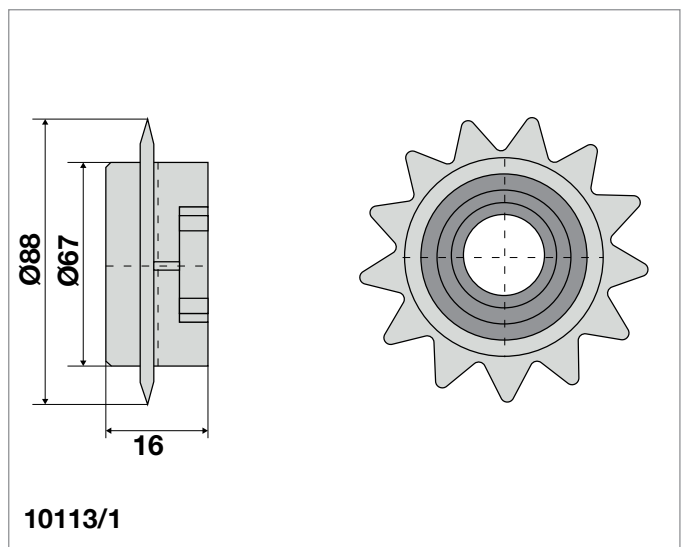
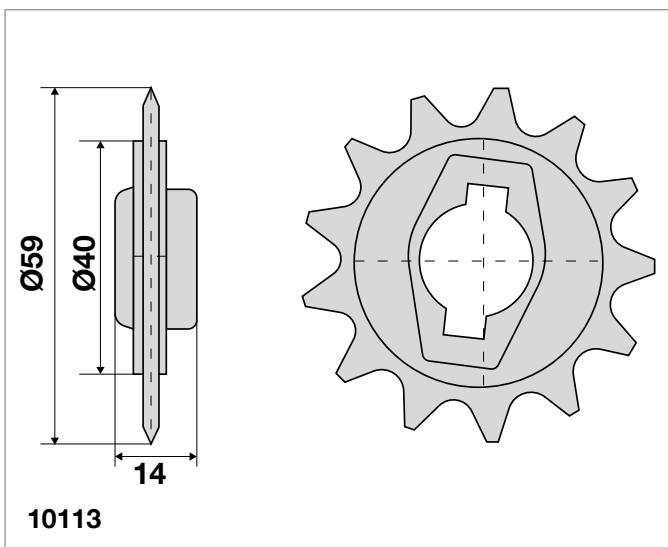

11

Codice / Code	Descrizione
10113	Pignone traente 13 denti per operatore tipo S FIAM
10113/1	Pignone di rinvio per porta automatica tipo S FIAM
8059/1	Puleggia con pignone per operatore S/2PO di cabina tipo S (foro Ø 25) FIAM

PIGNONI OPERATORI FIAM PINION FOR FIAM OPERATOR

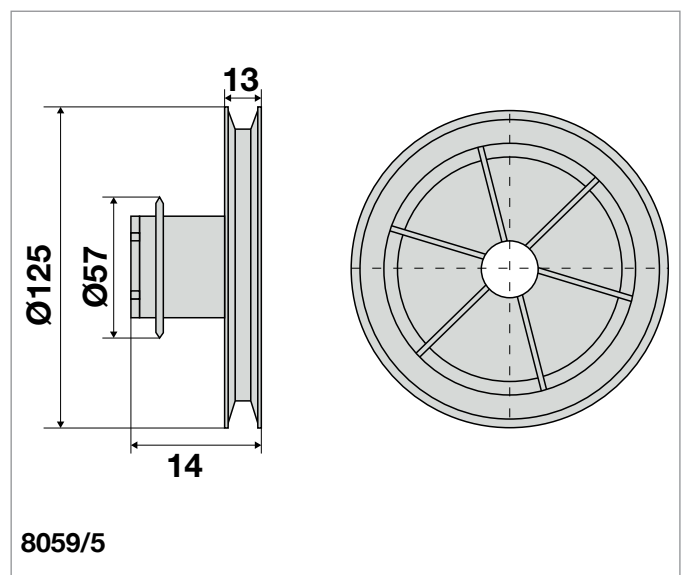
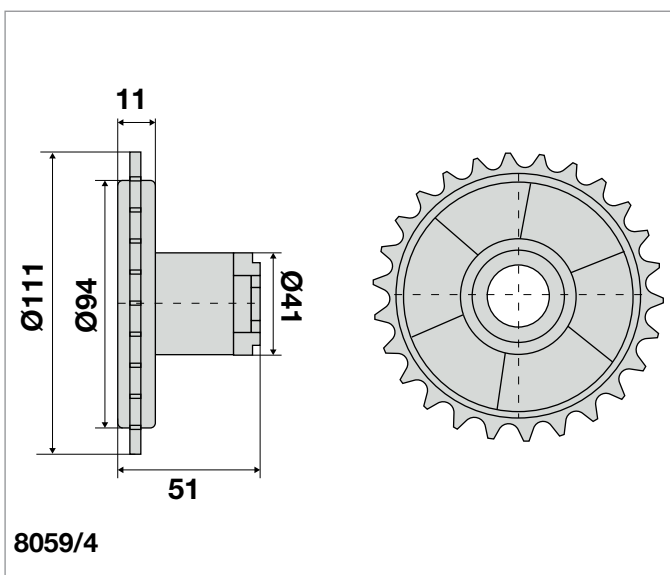
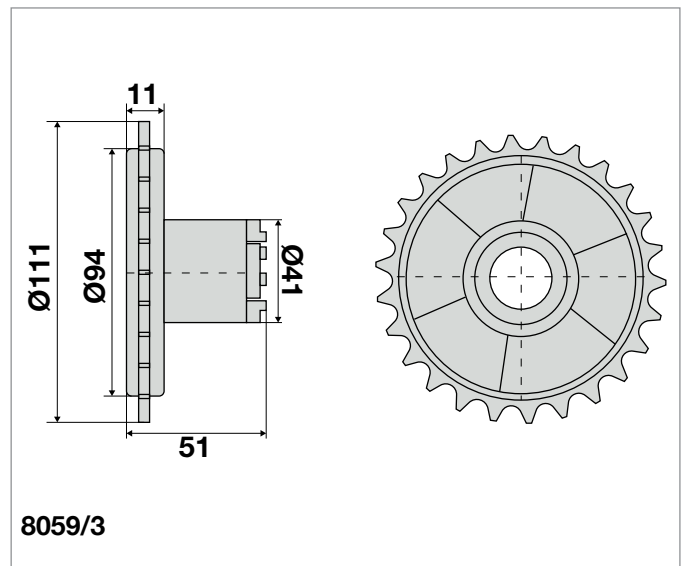
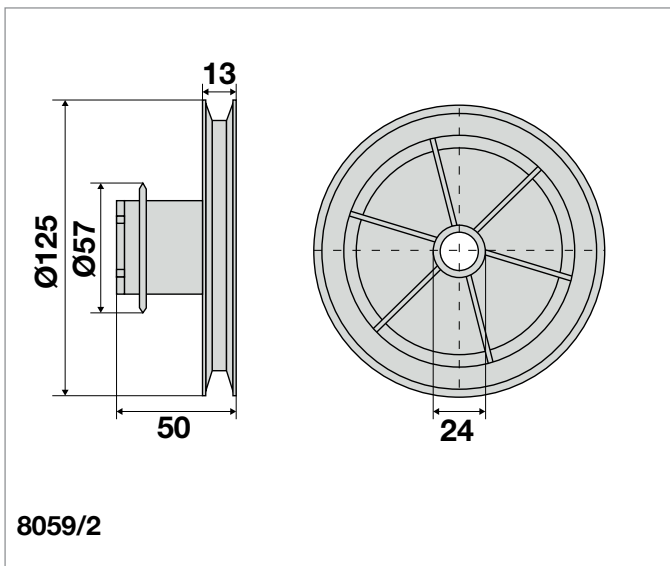

Codice / Code	Descrizione
8059/2	Puleggia con pignone per operatore di cabina tipo S (foro Ø 15 mm) FIAM
8059/3	Pignone di rinvio per porta automatica tipo S (foro Ø 25 mm) FIAM
8059/4	Pignone di rinvio per porta automatica tipo S (foro Ø 15 mm) FIAM
8059/5	Puleggia con pignone per operatore S/2PT - S/4PT di cabina tipo S (foro Ø 25 mm) FIAM

PIGNONI E INGRANAGGI FIAM PINION AND GEAR FIAM

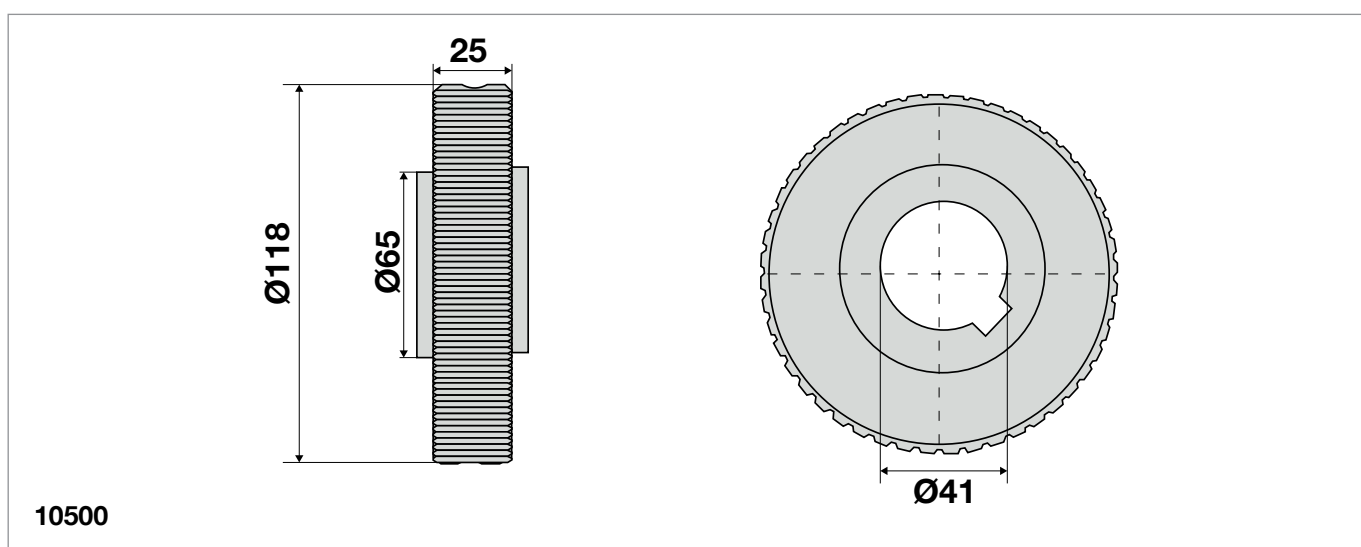

Codice / Code	Descrizione
10500	Ingranaggio in plastica motoriduttore tipo M041 FIAM
10500/1	Albero-corona in bronzo per motoriduttore MR041 FIAM

PIGNONI E INGRANAGGI OTIS - SABIEM
PINION AND GEAR OTIS - SABIEM

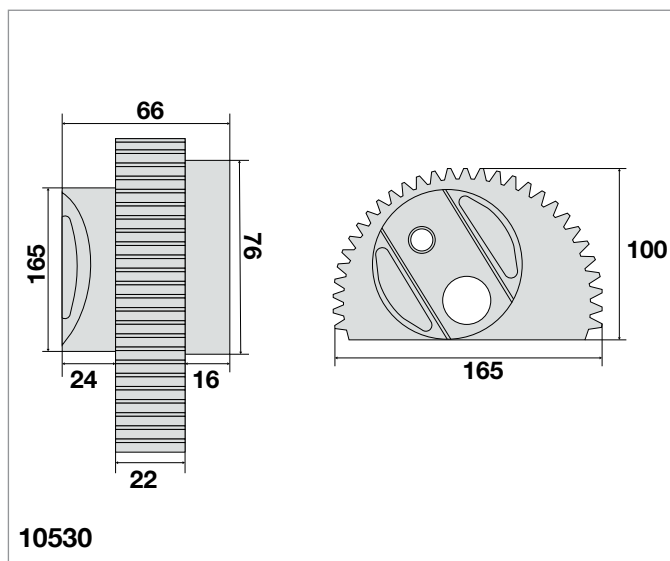
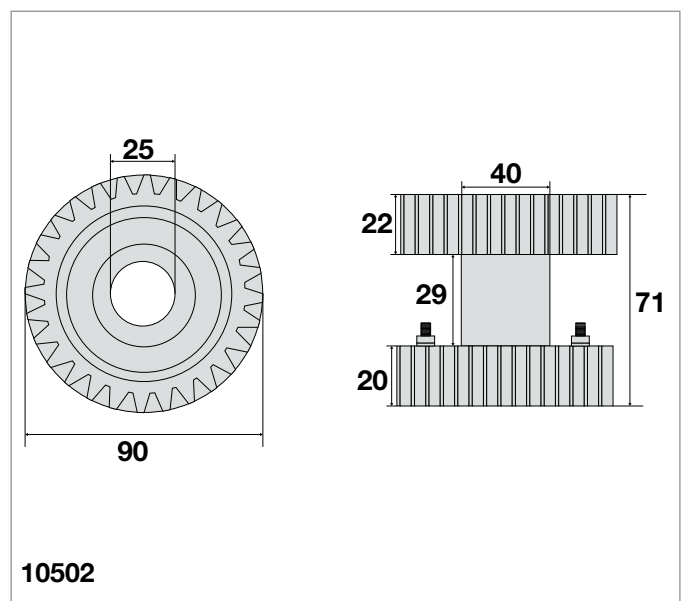
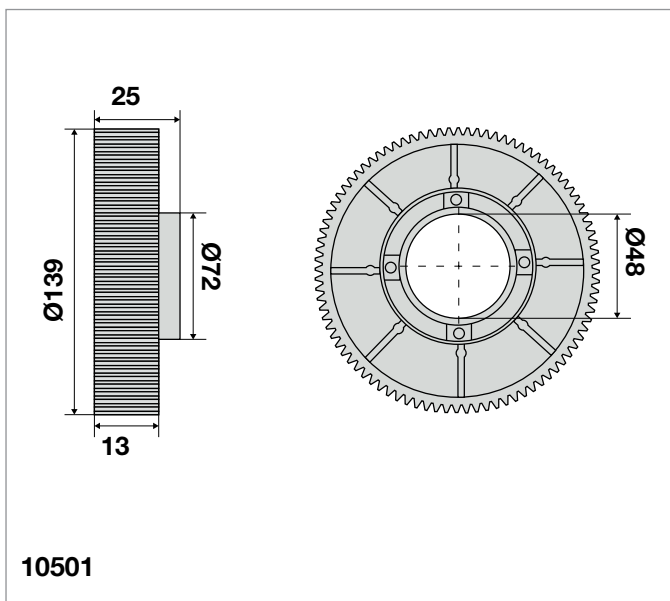

Codice / Code	Descrizione
10501	Ingranaggio operatore SABIEM
10502	Ingranaggio doppio per operatore OTIS
10530	Mezza ruota dentata OTIS

NOTE

**ELETTROMAGNETE PER PATTINO RETRATTILE - LEVE APRIFRENO ARGANO FIAM - ELETTROMAGNETE
FRENO ARGANO FIAM - INDICATORE LIVELLO OLIO SCHINDLER**

**ELECTROMAGNETS FOR RETIRING CAM - BRAKE RELEASE TRACTION LEVER FIAM - ELECTROMAGNET
FOR BRAKE RELEASE TRACTION FIAM - GEAR OIL LEVER INDICATOR FIAM**

Castello per leva aprifreno argano FIAM tipo 27 - 3N - 5N	12.6
<i>Brake release lever support for gear FIAM type 27 - 3N - 5N</i>	
Elettromagnete freno argano FIAM tipo 55 - 55N - 27 - 3N	12.7
<i>Electromagnetic brake release FIAM type 55 - 55N - 27 - 3N</i>	
Elettromagnete modello SS45 60 Vcc con snodo.....	12.3
<i>Electromagnet SS45 60 Vcc with joint</i>	
Elettromagneti con pattino retrattile incorporato	12.4
<i>Electromagnets with incorporated retiring cam</i>	
Elettromagneti con pattino frontale incorporato LG47-LG47/1 vecchia esecuzione FIAM	12.4
<i>Electromagnet with frontal incorporated cam for LG47-LG47/1 old execution FIAM</i>	
Elettromagneti con pattino retrattile antideflagrante grado ADPE EEX e II T4	12.5
<i>Electromagnets with explosions proof retiring cam ADPE EEX e II T4</i>	
Elettromagneti orizzontali	12.2
<i>Horizontal electromagnets</i>	
Indicatore livello olio argani SCHINDLER	12.7
<i>Traction oil level indicator SCHINDLER</i>	
Leva aprifreno argani FIAM tipo 27 - 3N - 5N	12.6
<i>Break release traction levers FIAM type 27 - 3N - 5N</i>	
Pattino retrattile corsa 58 mm sinistro e destro per elettromagnete SS45.....	12.3
<i>Retiring Cam moving 58 mm right and left for electromagnet SS45</i>	
Perno nucleo mobile elettromagnete freno argano FIAM tipo 27 - 3N - 5N	12.7
<i>Pivot for electromagnet movable gear FIAM type 27 - 3N - 5N</i>	
Perno per regolazione freno argano BASSETTI A400 - AO300 - AO400	12.6
<i>Pivot for regulate brake release BASSETTI A400 - AO300 - AO400</i>	

Note: I componenti sul catalogo con riportata una specifica marca di ascensore sono utilizzati abitualmente solo da questa marca. I particolari senza marca sono utilizzati da più marche di ascensori.

Note: The components in the catalogue with a specific lift brand are usually used only by the brand. Unbranded parts are used by multiple lift brands.

ELETTROMAGNETI ELECTROMAGNET



Elettromagnete orizzontale in corrente continua

Corsa: 27-30mm

Intermittenza: 80%

Trazione: 18kg/cm

Forza sul pattino: 5kg

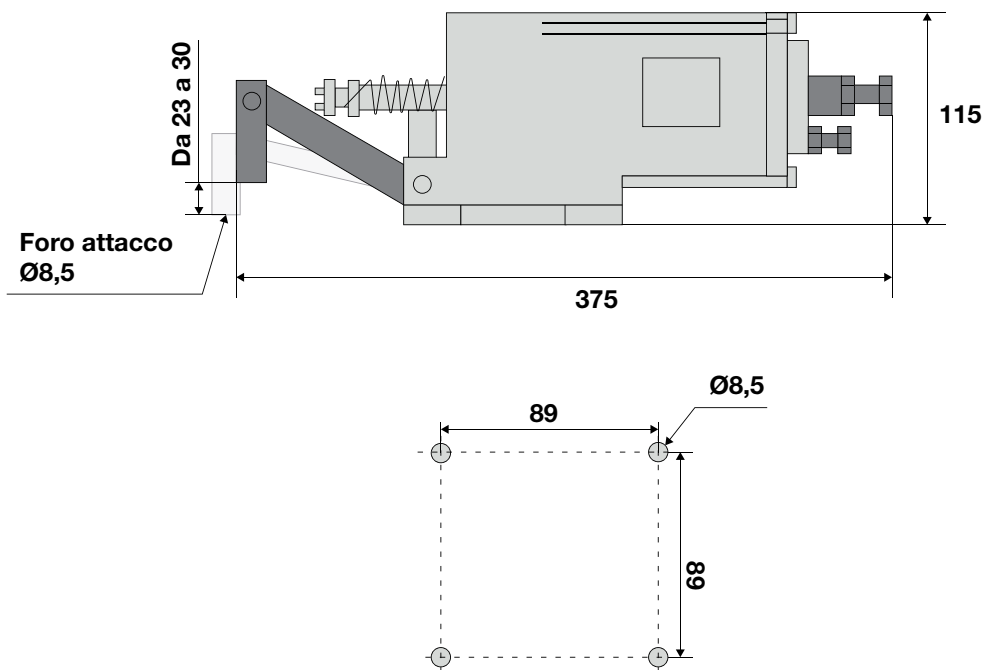

12

Codice / Code	Descrizione	Consumi in ampere
4000	Elettromagnete orizzontale 60V	2A
4001	Elettromagnete orizzontale 24V	2,4A
4002	Elettromagnete orizzontale 36V	2,6A
4003	Elettromagnete orizzontale 40V	2,5A
4004	Elettromagnete orizzontale 48V	2,5A
4005	Elettromagnete orizzontale 80V	1,33A
4006	Elettromagnete orizzontale 110V	1A

ELETTROMAGNETI ELECTROMAGNET

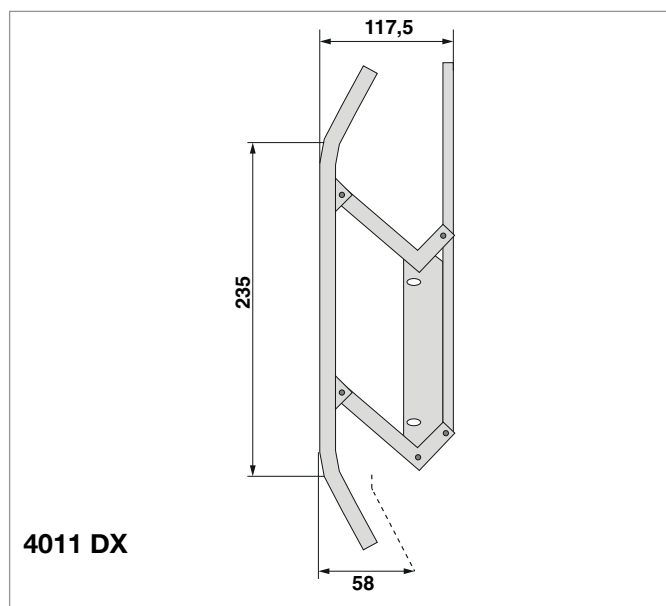
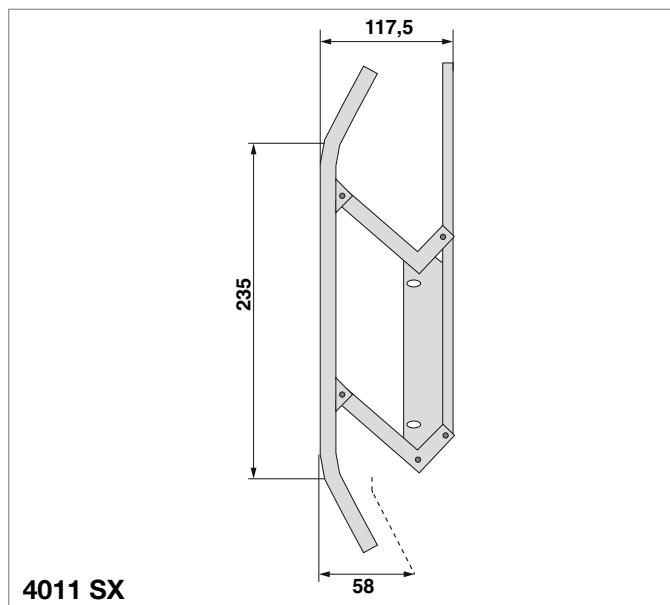
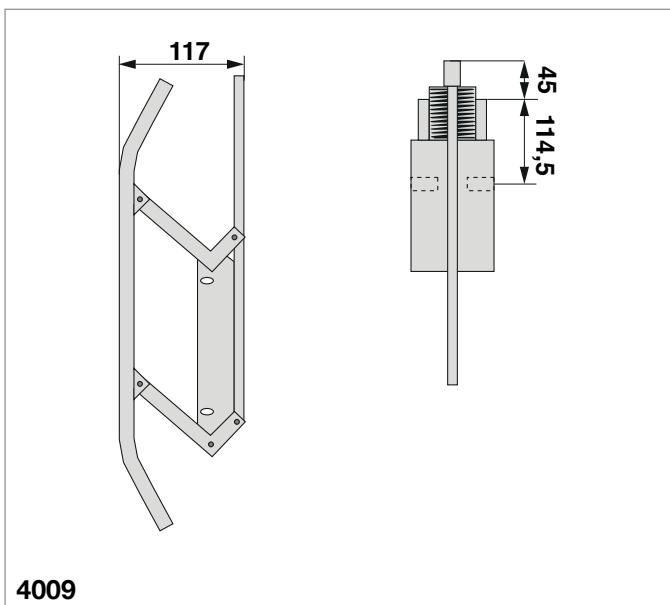

Codice / Code	Descrizione
4009	Elettromagnete modello SS45 60 Vcc con snodo
4011SX	Pattino retrattile corsa 58 mm sinistro per elettromagnete SS45
4011DX	Pattino retrattile corsa 58 mm destro per elettromagnete SS45

ELETTROMAGNETE CON PATTINO RETRATTILE FIAM ELECTROMAGNET WITH RETIRING CAM FIAM



Dal 4400 al 4406



4510

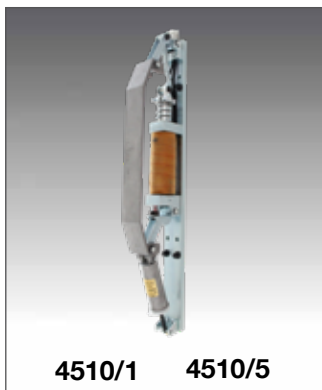

4510/1 4510/5

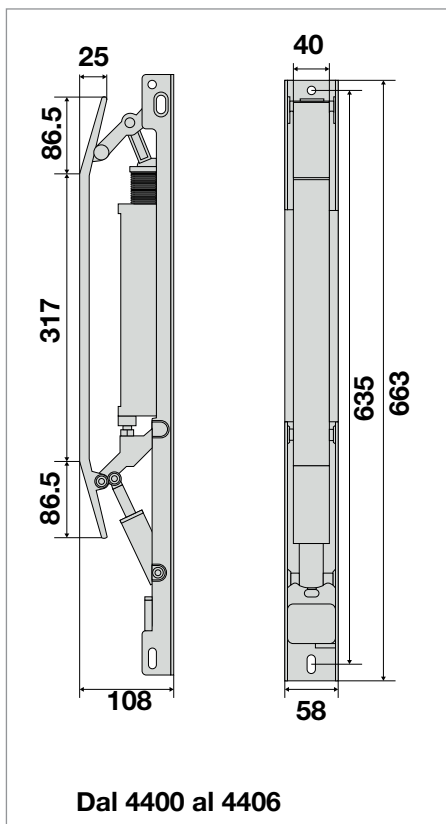

Dal 4400 al 4406

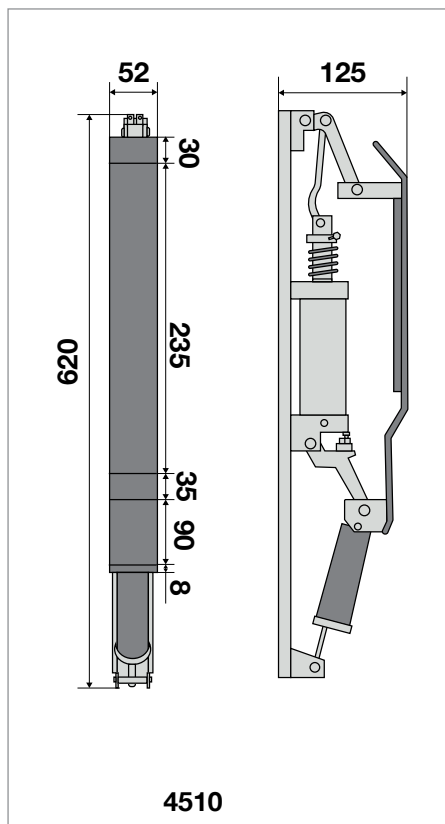

4510

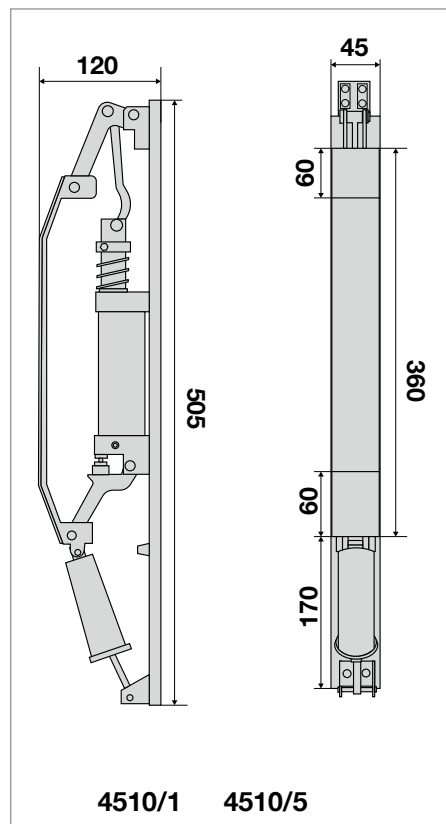

4510/1 4510/5

12

Codice / Code	Descrizione
4400	Elettromagnete con pattino retrattile incorporato 48 V.cc
4401	Elettromagnete con pattino retrattile incorporato 60 V.cc
4402	Elettromagnete con pattino retrattile incorporato 80 V.cc
4403	Elettromagnete con pattino retrattile incorporato 110 V.cc
4405	Elettromagnete con pattino retrattile incorporato 190 V.cc
4406	Elettromagnete con pattino retrattile incorporato 220 V.ac

Codice / Code	Descrizione
4510	Pattino elettromagnetico LG47/1(leva lunga) vecchia esecuzione FIAM
4510/1	Pattino elettromagnetico LG47 vecchia esecuzione FIAM 48 V.cc rinforzata
4510/5	Pattino elettromagnetico LG47 vecchia esecuzione FIAM 60 V.cc

ELETTROMAGNETI ELECTROMAGNET

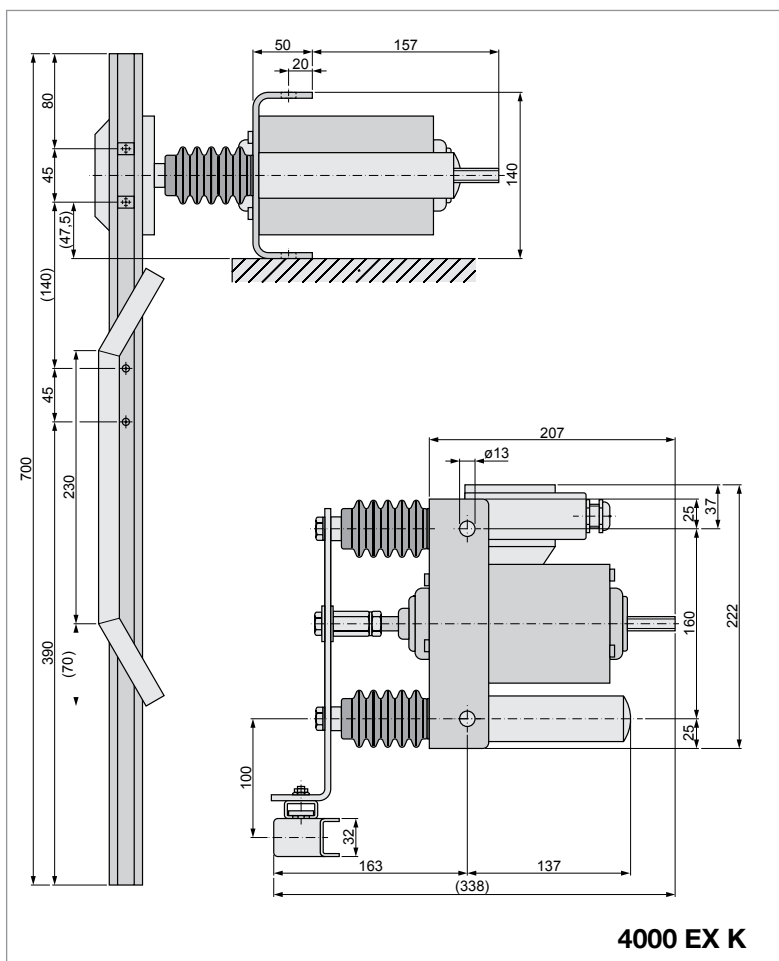
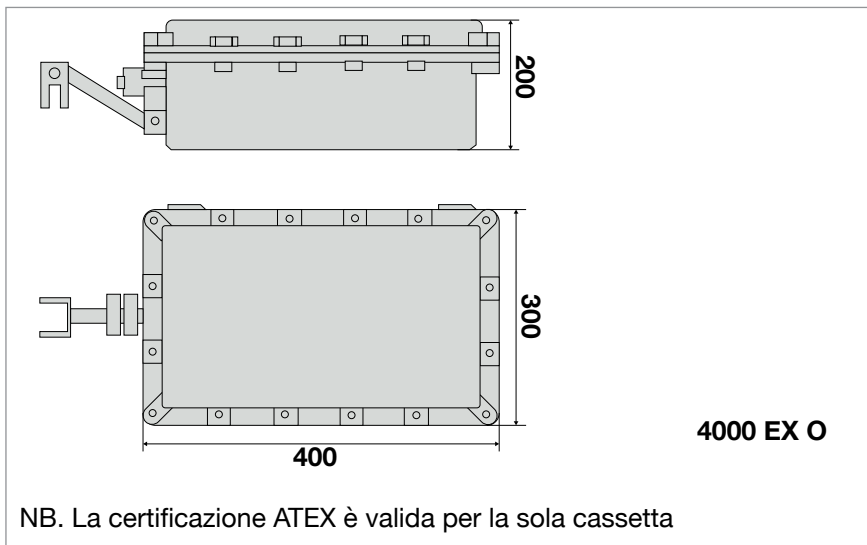

NB.1° specificare tensione ed inserzioni orarie

NB.1° Specify voltage and duty cycles

NB.2° Questo elettromagnete ha effettiva certificazione ATEX come elettromagnete ascensore

NB.2° This electromagnet has certification ATEX as electromagnet lift.

Codice / Code	Descrizione
4000 EX O	Elettromagnete per ascensori in versione antideflagrante
4000 EX K	Elettromagnete con pattino retrattile antideflagrante grado ADPE EEX e II T4

ACCESSORI PER ELETTROMAGNETI ARGANO FIAM - BASSETTI
ACCESSORIES FOR BRAKE ELECTROMAGNET FIAM - BASSETTI

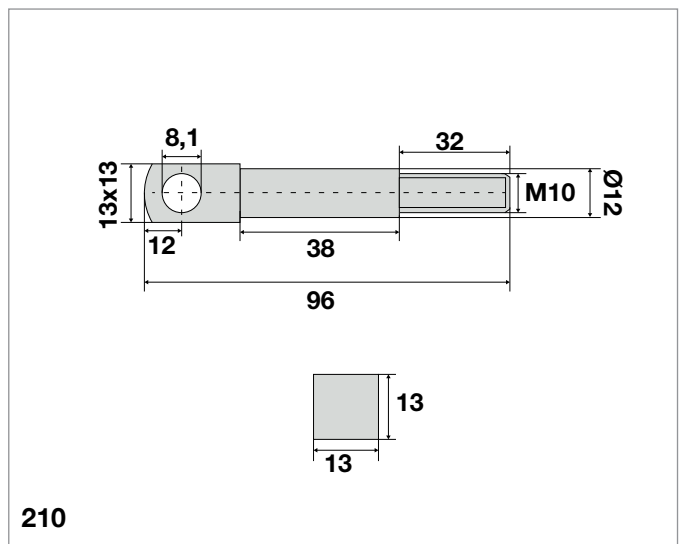
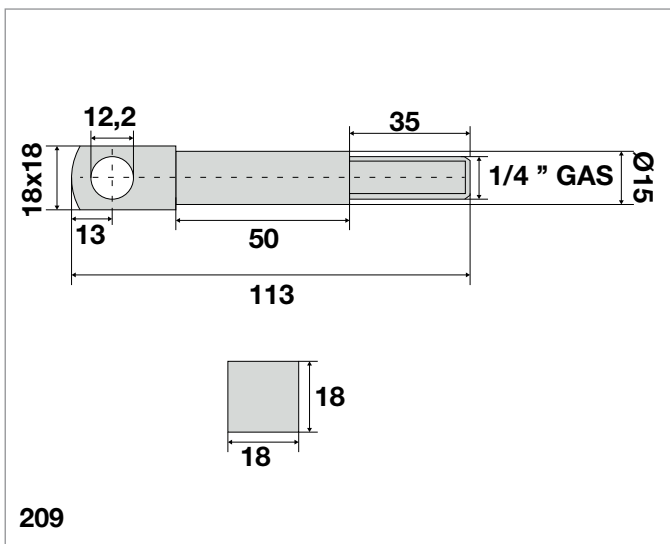
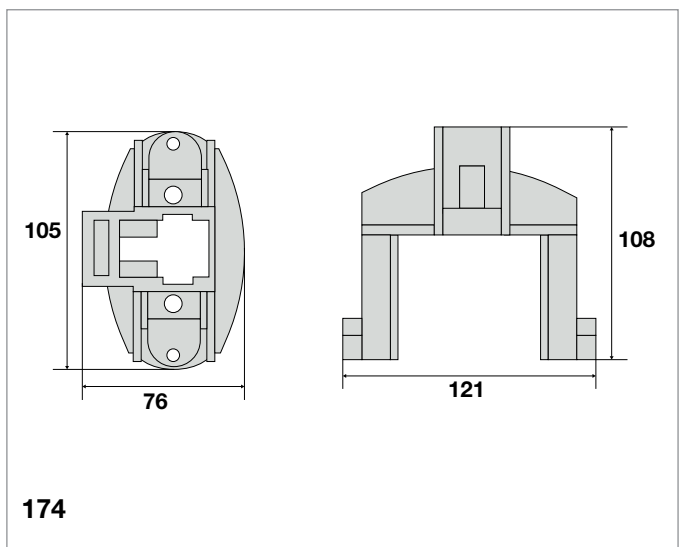
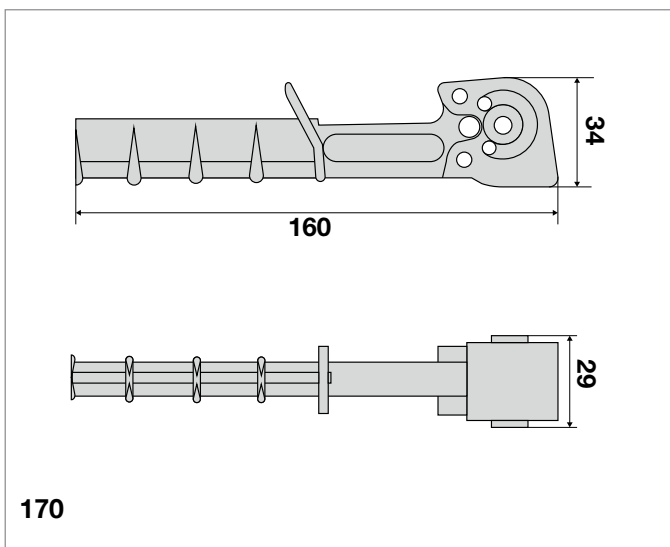

12

Codice / Code	Descrizione
170	Leva aprifreno argani tipo 27 - 3N - 5N FIAM
174	Castello per leva aprifreno argano tipo 27 - 3N - 5N FIAM
209	Asta per regolazione freno argano A400 - AO400 BASSETTI
210	Asta per regolazione freno argano A300 - AO300 BASSETTI

ACCESSORI PER ELETTROMAGNETI ARGANO FIAM - INDICATORE DI LIVELLO OLIO ARGANI SCHINDLER
ACCESSORIES FOR BRAKE ELECTROMAGNETS FIAM - BRAKE GEAR OIL LEVEL INDICATOR SCHINDLER

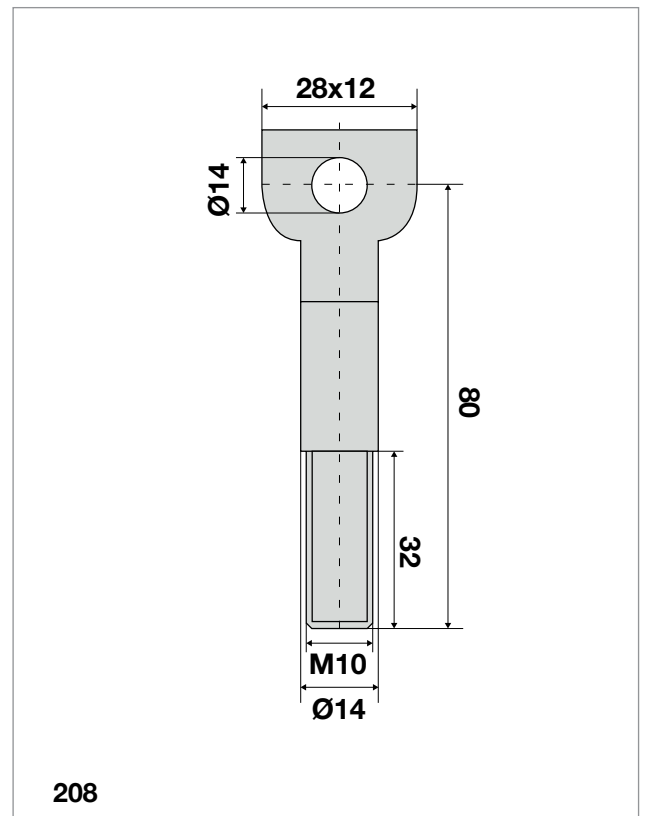
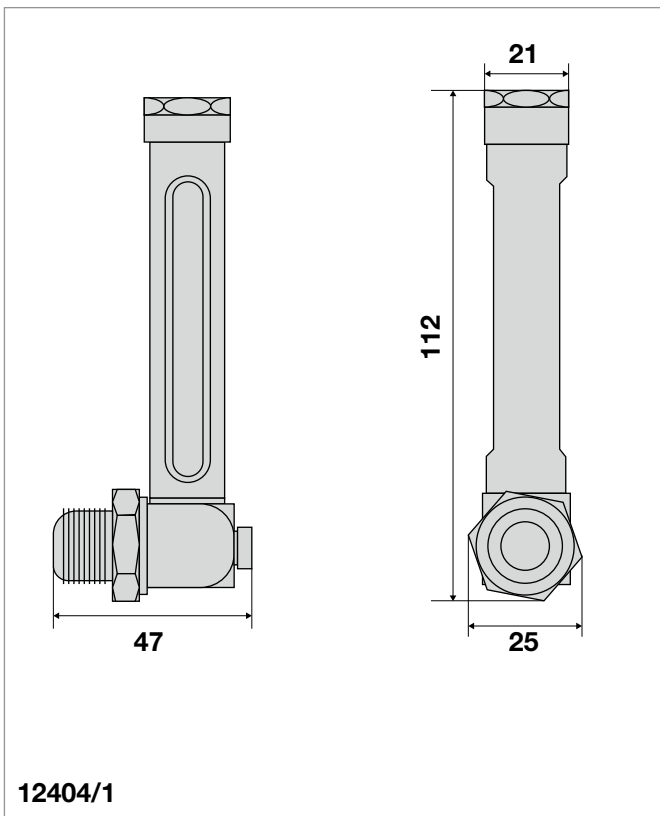

Codice / Code	Descrizione
12404/1	Indicatore di livello olio per argani SCHINDLER
208	Perno nucleo mobile elettromagnete freno argano 27- 3N - 5N FIAM
4600	Elettromagnete freno argano FIAM tipo 27-3N rinforzato
4600/A	Elettromagnete freno argano FIAM tipo 5N rinforzato
4600/B	Elettromagnete freno argano FIAM tipo 55

NOTE

PATTINI RETRATTILI VARI, CAMME SCIVOLI DI ABBINAMENTO OPERATORE PORTE PIANO FIAM E SCHINDLER QKS8 - QKS9

VARIOUS RETIRING CAMS, CAM AND SLIDE COUPLING OPERATOR FOR LANDING DOOR FIAM AND SCHINDLER QKS8 - QKS9

Assieme camma e scivolo di abbinamento DX - SX per operatore B/2PT e per automatismo B/2PO FIAM 13.5
Cam and slide of left and right for coupling right and left for operator B/2PT and for automatic B/2PO FIAM

Pattino con molla incorporata a cavo 13.3
Retiring cam with spring embedded at rope

Pattino fisso incassato per elettromagnete e a spostamento laterale ambidestro FURINI 13.4
Cam built-in fix for electromagnet with ambidextrous side change FURINI

Pattino retrattile corsa lunga 13.2
Retiring cam long stroke

Pattino retrattile standard ambidestro 13.2
Standard ambidextrous retiring cam

Pattino retrattile standard ambidestra in materiale plastico nero 13.2
Standard ambidextrous retiring cam with black plastic material

Pattino retrattile per elettromagnete SCHINDLER 13.3
Retiring cam for electromagnet SCHINDLER

Pattino elastico retrattile ambidestro 13.4
Ambidextrous elastic retiring cam

Pattino retrattile corsa lunga SELCOM 13.10
Retiring cam long stroke for SELCOM

Ricambi operatore SCHINDLER QKS 8 - QKS 9 (Biellette/cinghia, assieme camma e scivoli) .. 13.6 - 13.7 - 13.8 - 13.9
Spare parts for SCHINDLER QKS 8 - QKS 9 operator (Rod/belt, cam and vane together)

Note: I componenti sul catalogo con riportata una specifica marca di ascensore sono utilizzati abitualmente solo da questa marca. I particolari senza marca sono utilizzati da più marche di ascensori.

Note: The components in the catalogue with a specific lift brand are usually used only by the brand. Unbranded parts are used by multiple lift brands.

PATTINI RETRATTILI RETIRING CAM

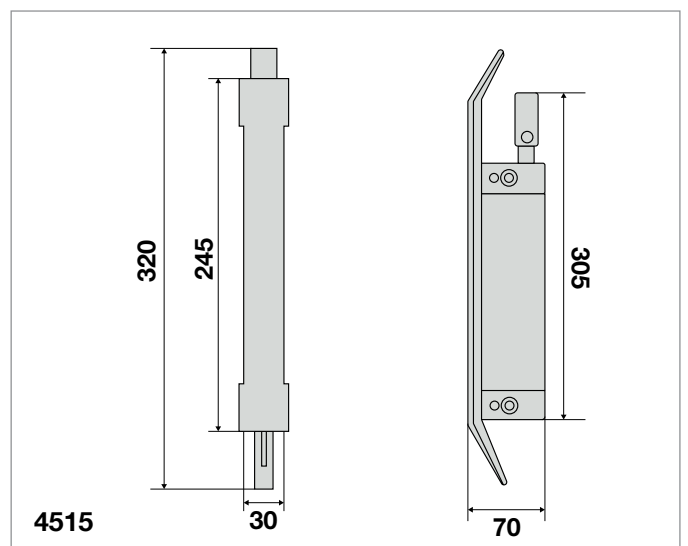
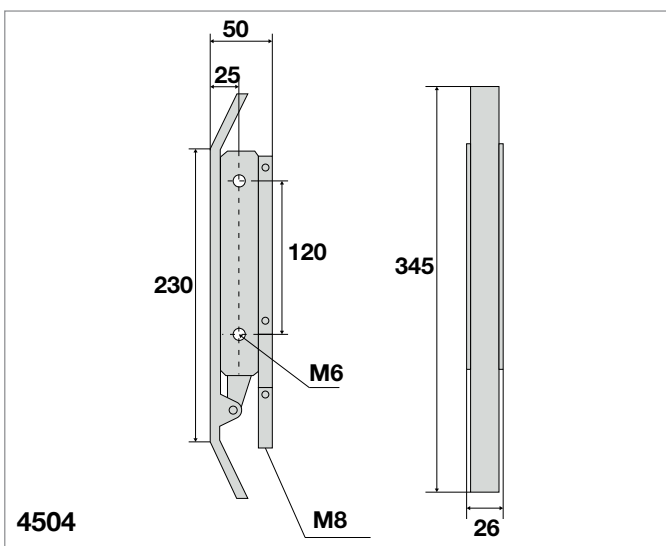
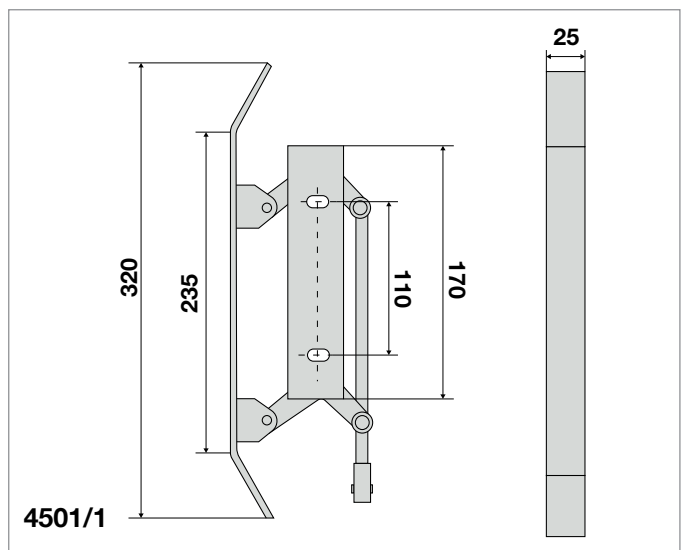
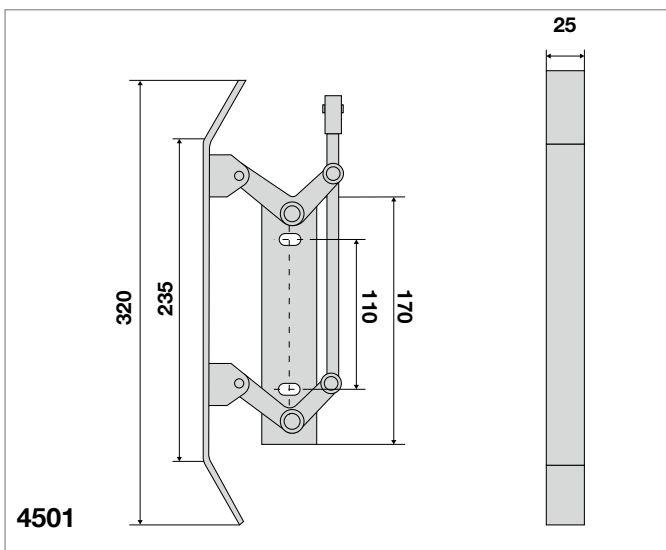

Codice / Code	Descrizione
4501	Pattino retrattile corsa lunga destro
4501/1	Pattino retrattile corsa lunga sinistro
4504	Pattino retrattile standard ambidestro
4515	Pattino retrattile standard ambidestro in materiale plastico nero

PATTINI RETRATTILI RETIRING CAMS

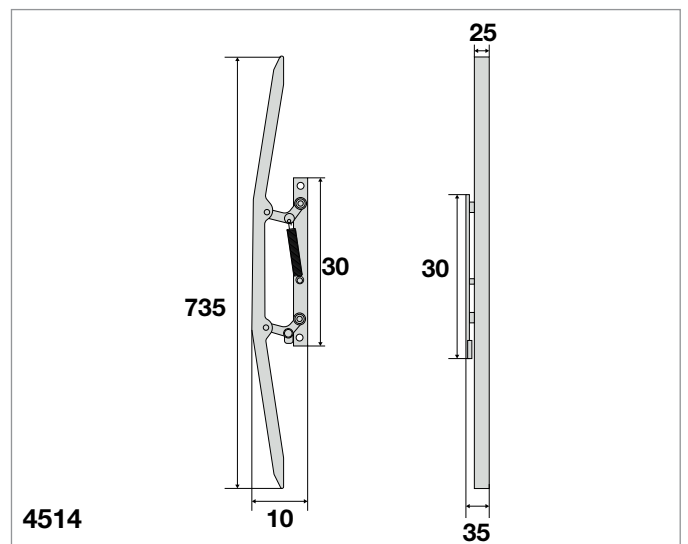
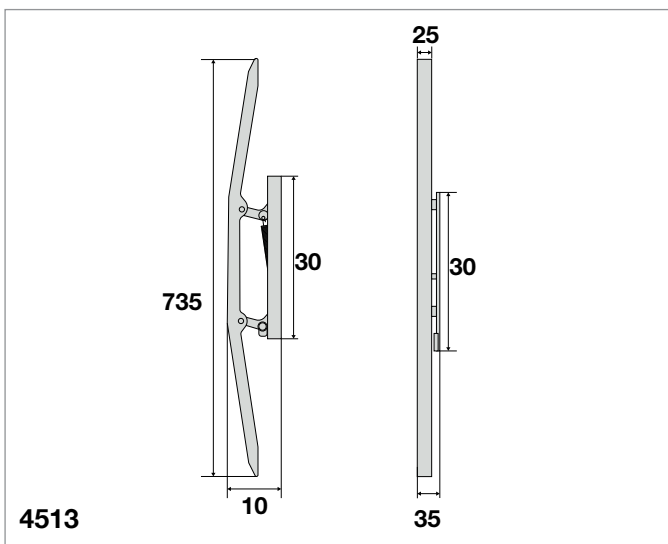
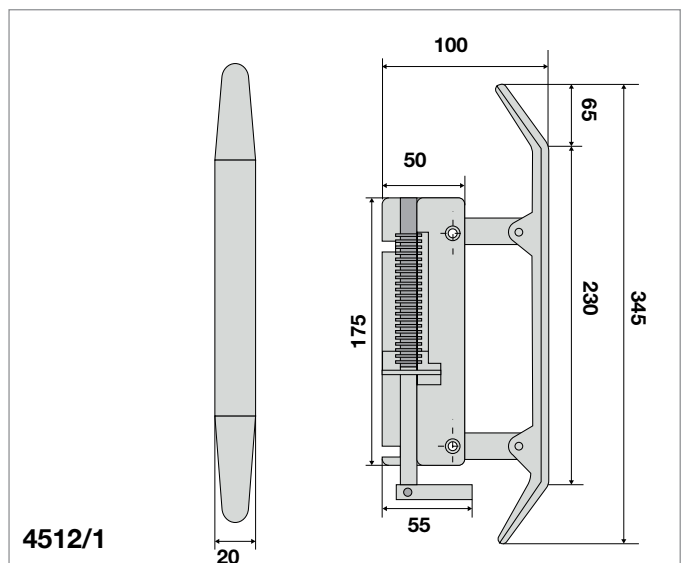
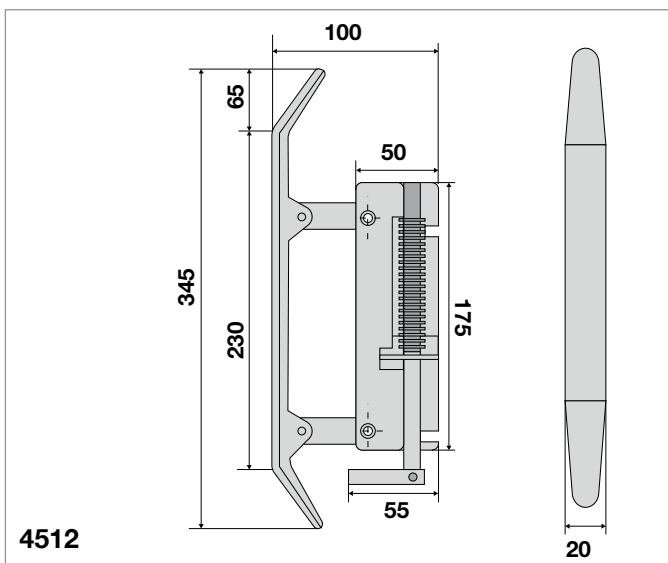
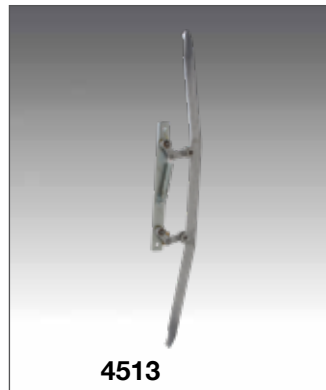

Codice / Code	Descrizione
4512	Pattino retrattile con molla incorporata trazione a cavo destro
4512/1	Pattino retrattile con molla incorporata trazione a cavo sinistro
4513	Pattino retrattile per elettromagnete SCHINDLER destro
4514	Pattino retrattile per elettromagnete SCHINDLER sinistro

PATTINI RETRATTILI RETIRING CAMS

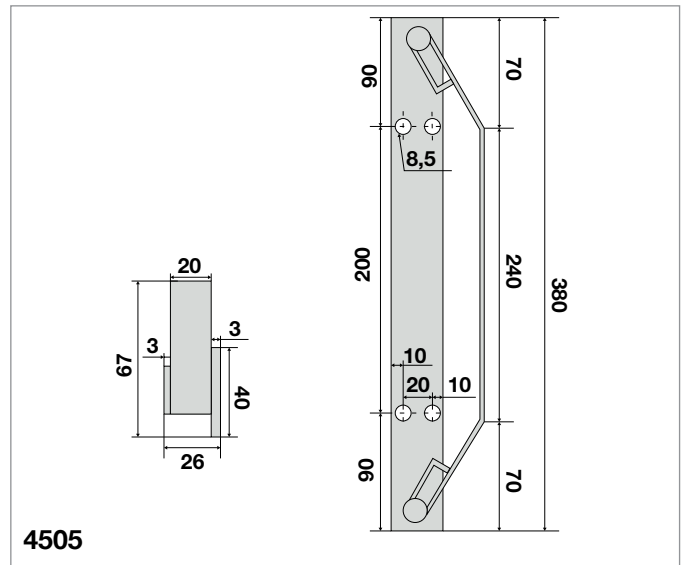
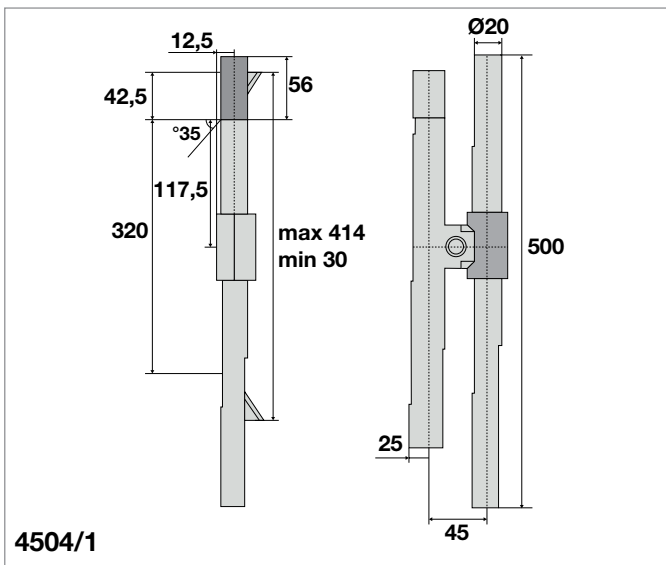

Codice / Code	Descrizione
4504/1	Pattino fisso incassato per elettromagnete a spostamento laterale ambidestro SA43/SA41 (In esaurimento)
4505	Pattino elastico retrattile ambidestro

ACCESSORI PER AUTOMATISMI ACCESSORIES FOR AUTOMATIC DOOR

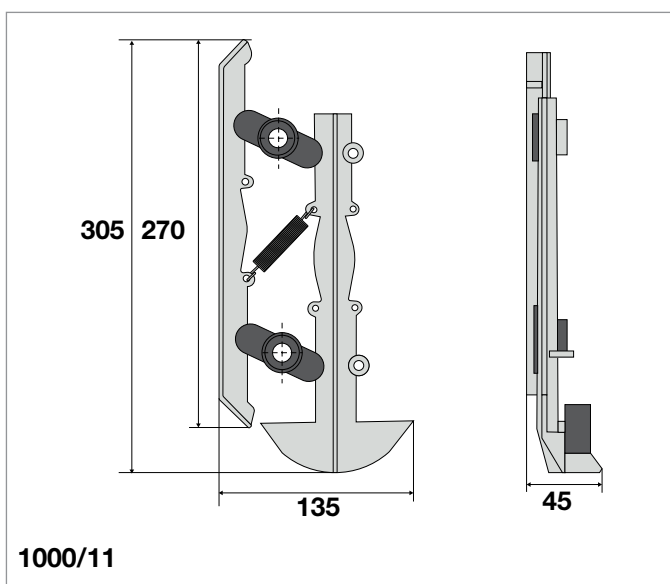
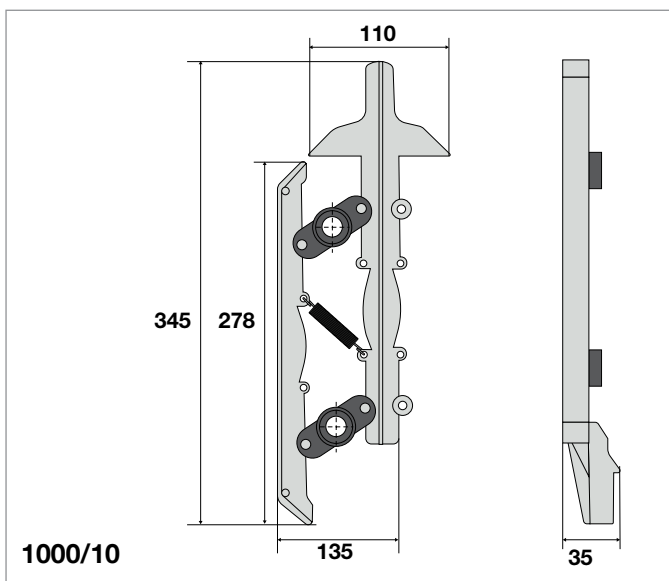
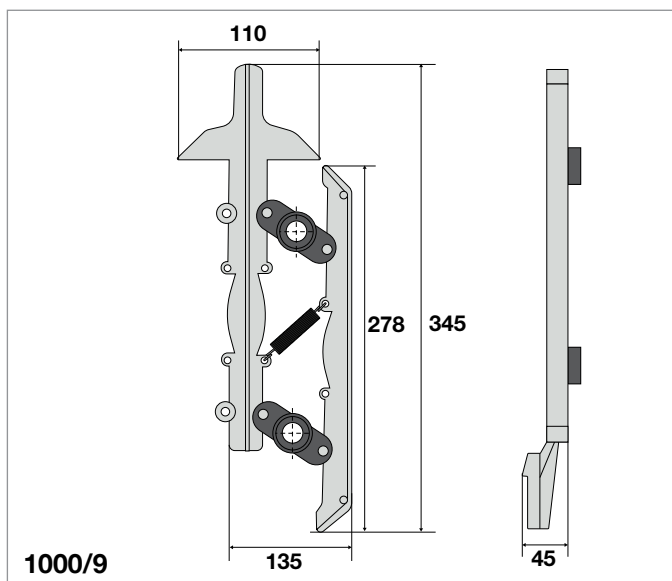
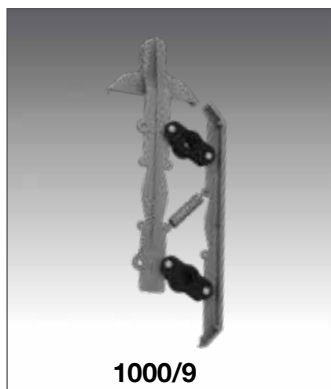

Codice / Code	Descrizione
1000/9	Assieme camma e scivolo di abbinamento DX per operatore B/2PT FIAM
1000/10	Assieme camma e scivolo di abbinamento SX per operatore B/2PT FIAM
1000/11	Assieme camma e scivolo di abbinamento per automatismo B/2PO FIAM

**RICAMBI OPERATORE SCHINDLER - BIELLE, ASSIEME CAMME E SCIVOLI
 ABBINAMENTO PORTE QKS 9
 SCHINDLER SPARE PARTS FOR ASSEMBLING ROD - VANE CAM FOR DOOR
 COUPLING QKS 9**



Raffigurati operatori SCHINDLER

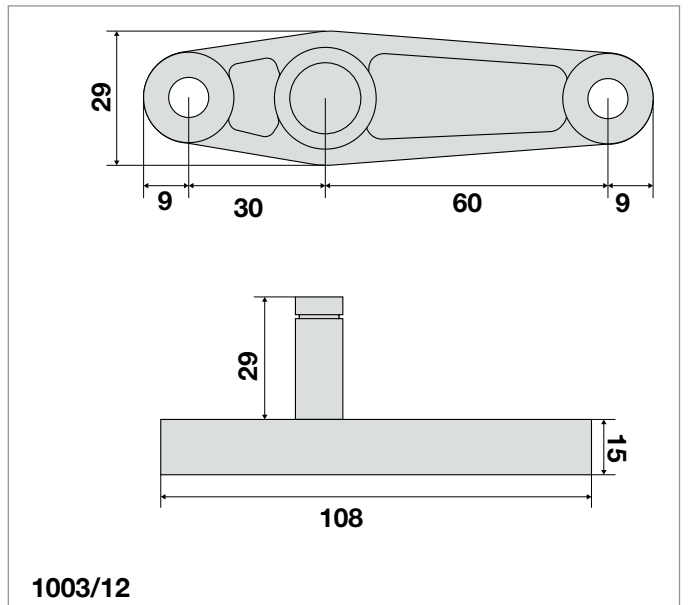
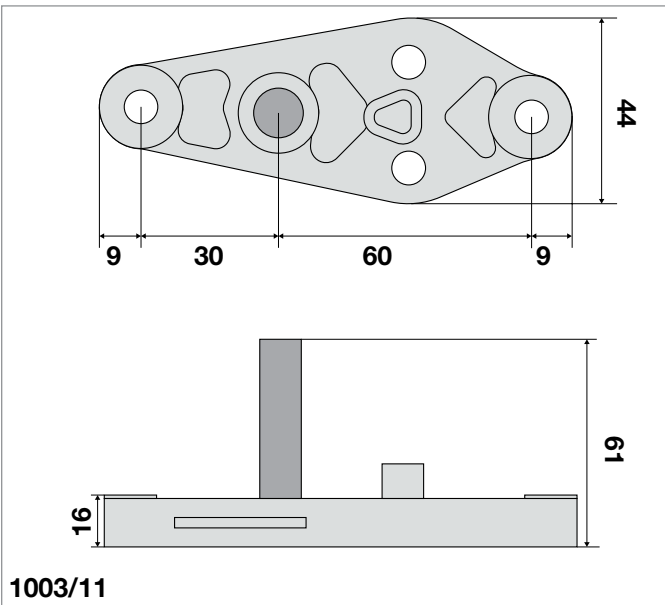

13

Bielletta per assieme camma e scivolo di abbinamento da 700mm per QKS 9
 Rod for assembling cam and vane for coupling QKS 9 from 700mm

Codice / Code	Descrizione
1003/11	Bielletta per QKS 9
1003/12	Bielletta per QKS 9

**RICAMBI OPERATORE SCHINDLER - BIELLE, ASSIEME CAMME E SCIVOLI
 ABBINAMENTO PORTE QKS 8
 SCHINDLER SPARE PARTS FOR ASSEMBLING ROD - VANE CAM FOR DOOR
 COUPLING QKS 8**

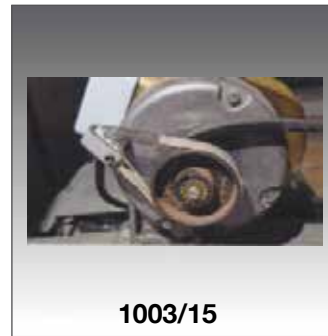

Raffigurati operatori SCHINDLER

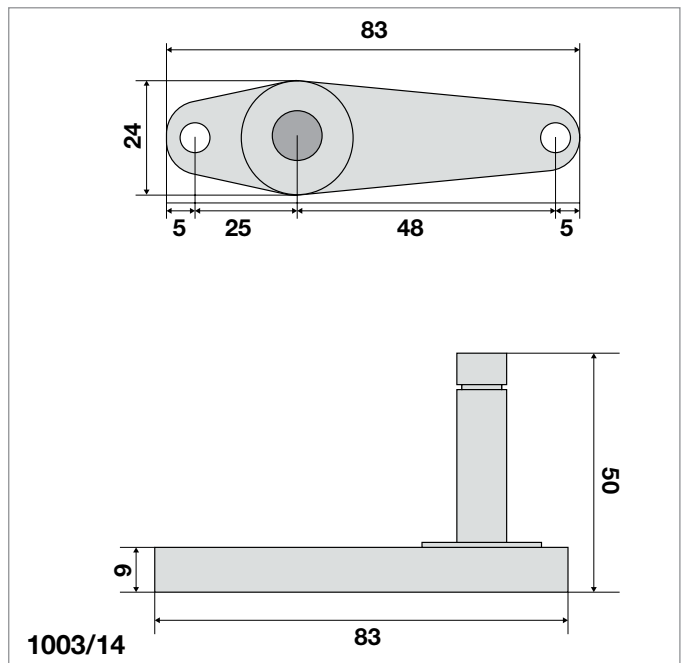
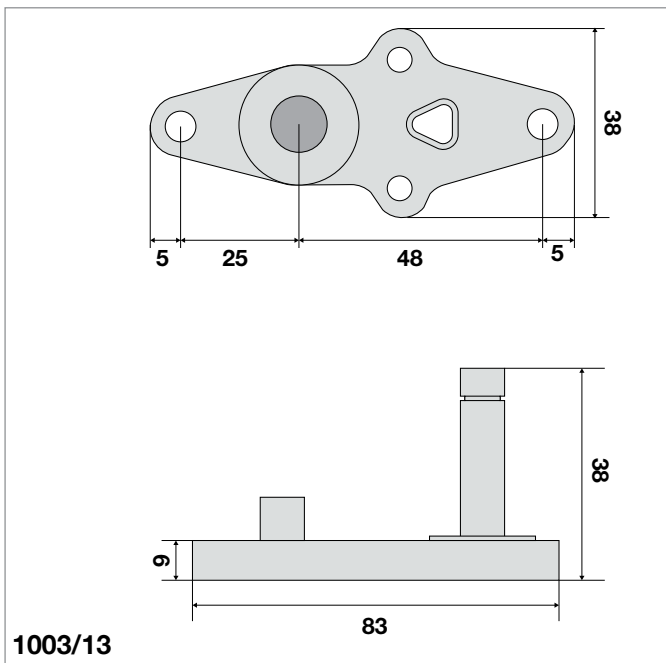

Bielletta per assieme camma e scivolo di abbinamento da 700mm per QKS 8
 Rod for assembling cam and vane for coupling QKS 8 from 700mm

Codice / Code	Note
1003/13	Bielletta alta per QKS 8
1003/14	Bielletta bassa per QKS 8
1003/15	Cinghia benda Schindler

**RICAMBI OPERATORE SCHINDLER - BIELLE, ASSIEME CAMME E SCIVOLI
 ABBINAMENTO PORTE QKS 8 - QKS 9
 SCHINDLER SPARE PARTS FOR ASSEMBLING ROD - VANE CAM FOR DOOR
 COUPLING QKS 8 - QKS 9**

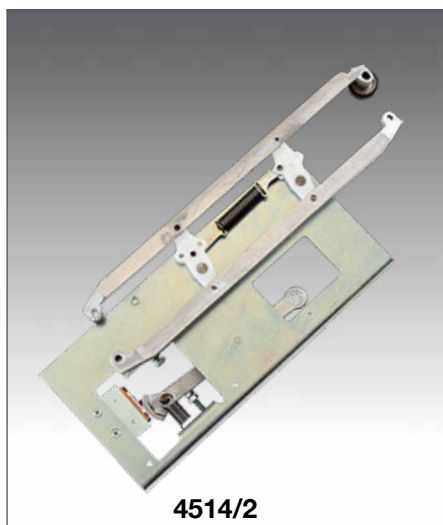

4514/2



4514/4



4514/6

Codice / Code	Descrizione
4514/1	Assieme camma e scivolo di abbinamento per QKS 8 (destra)
4514/2	Assieme camma e scivolo di abbinamento per QKS 8 (sinistra)
4514/3	Assieme camma e scivolo di abbinamento per QKS 9 (L.700 mm destra)
4514/4	Assieme camma e scivolo di abbinamento per QKS 9 (L.700 mm sinistra)
4514/5	Assieme camma e scivolo di abbinamento con apertura centrale per QKS 8 (L.700 mm destra)
4514/6	Assieme camma e scivolo di abbinamento con apertura centrale per QKS 8 (L.700 mm sinistra)

**RICAMBI OPERATORE SCHINDLER - BIELLE, ASSIEME CAMME E SCIVOLI
 ABBINAMENTO PORTE QKS8
 SCHINDLER SPARE PARTS FOR ASSEMBLING ROD - VANE CAM FOR DOOR
 COUPLING QKS 8**

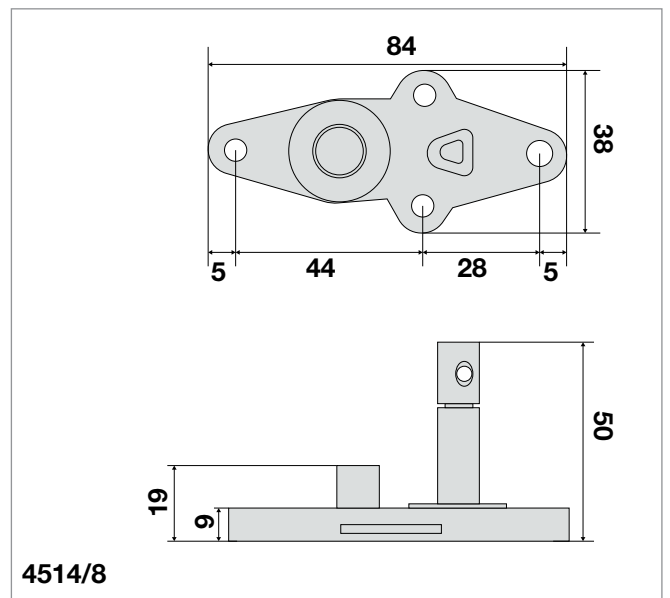
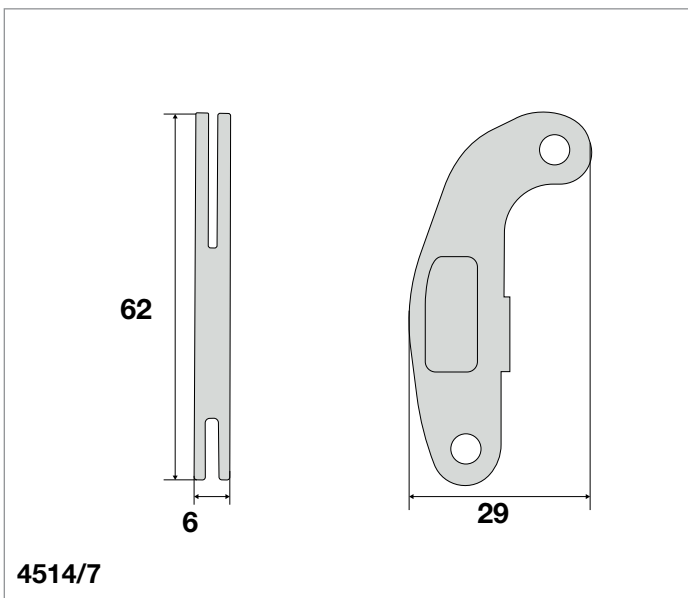
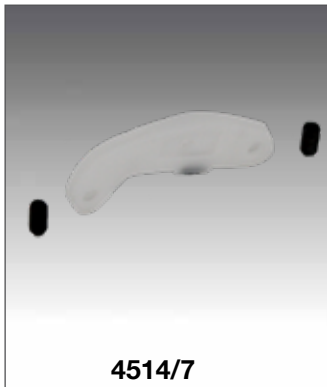

Codice / Code	Descrizione
4514/7	Bielletta braccio operatore SCHINDLER QKS 8
4514/8	Biella navetta alta per camma e scivolo di abbinamento con apertura centrale operatore SCHINDLER QKS 8
4514/9	Scivolo L.460 mm per operatore SCHINDLER QKS 8 (destra)
4514/10	Scivolo L.460 mm per operatore SCHINDLER QKS 8 (sinistra)
4514/11	Scivolo L.500 mm per operatore SCHINDLER QKS 8

SCIVOLO ABBINAMENTO RETRATTILE SELCOM VANE COUPLING RETIRING FOR SELCOM

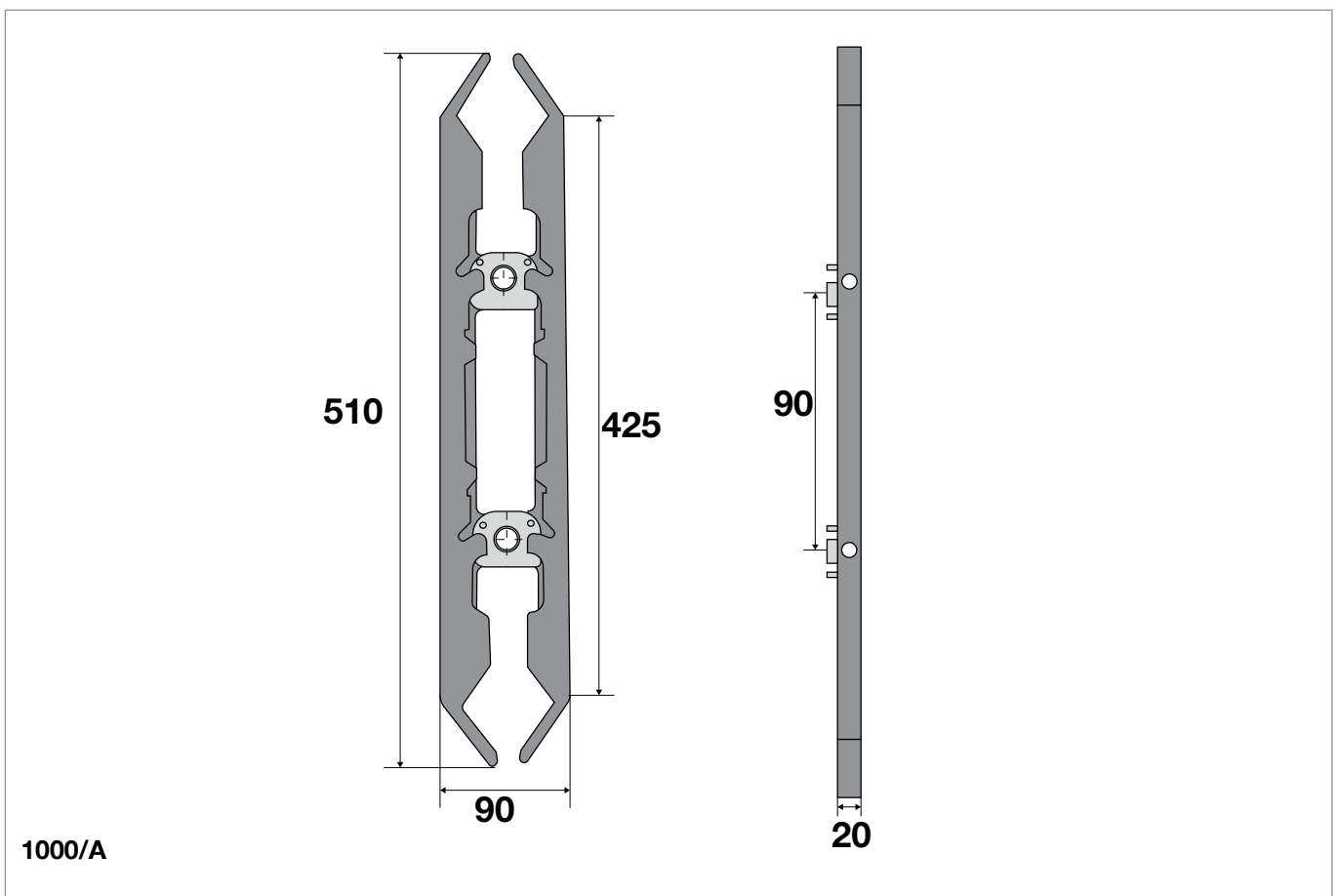

13

Codice / Code	Descrizione
1000/A	Scivolo abbinamento retrattile SELCOM

SERRATURE PER PORTE DI PIANO A BATTENTE SEMIAUTOMATICHE A 1 O 2 CATENACCI - A POMOLO E A CHIAVE - ANCHE STAGNE E ANTINDEFLAGRANTI - RICAMBI

DOOR LOCKS FOR SEMIAUTOMATIC LANDING DOORS WITH 1 OR 2 BOLTS - A KNOB AND KEY - ALSO WATERPROOF AND EXPLOSION PROOF - SPARE PARTS FOR LOCKS

SERRATURE SEMIAUTOMATICHE

SEMIAUTOMATIC DOOR LOCKS

Serratura AKRON semiautomatica	14.6
<i>Semiautomatic door lock AKRON</i>	
Serratura BASSETTI semiautomatica	14.7
<i>Semiautomatic door lock BASSETTI</i>	
Serratura BONFEDI semiautomatica	14.8
<i>Semiautomatic door lock BONFEDI</i>	
Serratura CAN LIFT intercambiabile TF	14.29
<i>Door lock CAN LIFT interchangeable TF</i>	
Serratura CAN LIFT intercambiabile TF con leva 90° interna ed esterna	14.29-14.30
<i>Door lock CAN LIFT interchangeable TF with lever to 90° internal and external</i>	
Serratura CIOCCA semiautomatica tipo vecchio e tipo nuovo	14.8
<i>Semiautomatic door lock CIOCCA type old and new</i>	
Serratura DALLAGIOVANNA semiautomatica	14.8
<i>Semiautomatic door lock DALLAGIOVANNA</i>	
Serratura DMG semiautomatica a incasso e sovrapposta	14.9
<i>Semiautomatic door lock dmg in flush-mounted and overlaid</i>	
Serratura FALCONI semiautomatica	14.10
<i>Semiautomatic Door lock FALCONI</i>	
Serratura FEMER semiautomatica	14.9
<i>Semiautomatic door lock FEMER</i>	
Serratura FIAM semiautomatica	14.11
<i>Semiautomatic door lock FIAM</i>	
Serratura FORSID/MONITOR semiautomatica anche con piastra spingere	14.10
<i>Semiautomatic door lock FORSID/MONITOR with push plate</i>	

Serratura FURINI semiautomatica	14.12
<i>Semiautomatic door lock FURINI</i>	
Serratura INSUBRIA-ATLAS semiautomatica	14.12
<i>Semiautomatic door lock INSUBRIA-ATLAS</i>	
Serratura KRONENBERG semiautomatica	14.13-14.14-14.15-14.16-14.17-14.18
<i>Semiautomatic door lock KRONENBERG</i>	
Serratura OTIS semiautomatica	14.19
<i>Semiautomatic door lock OTIS</i>	
Serratura PRUDHOMME LR 128 elettrica	14.20
<i>Door lock PRUDHOMME LR 128 electronic</i>	
Serratura PRUDHOMME OTIS ASCINTER FCO 9538B movimento perpendicolare	14.21
<i>Door lock PRUDHOMME OTIS ASCINTER FCO 9538B movement perpendicular</i>	
Serratura PRUDHOMME OTIS ASCINTER FCO 9538A movimento laterale	14.22
<i>Door lock PRUDHOMME OTIS ASCINTER FCO 9538A with lateral unlocking</i>	
Serratura PRUDHOMME SCHINDLER HE1-HE2	14.23
<i>Door lock PRUDHOMME SCHINDLER HE1-HE2</i>	
Serratura ROCE semiautomatica	14.12
<i>Semiautomatic door lock ROCE</i>	
Serratura SABIEM semiautomatica	14.24
<i>Semiautomatic door lock SABIEM</i>	
Serratura SAFOV semiautomatica sopra porta	14.25
<i>Semiautomatic door lock SAFOV above door</i>	
Serratura SCHINDLER semiautomatica porte legno	14.26
<i>Door lock SCHINDLER for semiautomatic wooden door</i>	
Serratura SCHINDLER semiautomatica	14.26
<i>Semiautomatic door lock SCHINDLER</i>	

Serratura SICEM semiautomatica	14.26
<i>Semiautomatic door lock SICEM</i>	
Serratura TESIO semiautomatica	14.12
<i>Semiautomatic door lock TESIO</i>	
Serratura TF semiautomatica con elettromagnete.....	14.27
<i>Semiautomatic door lock TF with electromagnet</i>	
Serratura TF semiautomatica doppio catenaccio.....	14.27
<i>Semiautomatic door lock TF double lock latch</i>	
Serrature TF semiautomatiche	14.28
<i>Semiautomatic door lock TF</i>	
Serratura UCE semiautomatica	14.34
<i>Semiautomatic door lock UCE</i>	
Serratura WENGHEL semiautomatica	14.34
<i>Semiautomatic door lock WENGHEL</i>	

SERRATURE A POMOLO MANUALI

MANUAL DOOR LOCKS WITH KNOB

Serratura BASSETTI non omologata e omologata	14.35
<i>Door lock BASSETTI not approved and approved</i>	
Serratura BONFEDI	14.36
<i>Door lock BONFEDI</i>	
Serratura BOSISIO	14.45
<i>Door lock BOSISIO</i>	
Serratura DALLAGIOVANNA	14.36
<i>Door lock DALLAGIOVANNA</i>	

Serratura DMG	14.37-14.38-14.39
<i>Door lock DMG</i>	
Serratura FALCONI	14.40
<i>Door lock FALCONI</i>	
Serratura FIAM	14.42-14.43
<i>Door lock FIAM</i>	
Serratura FORSID/MONITOR omologata	14.44
<i>Door lock FORSID/MONITOR approved</i>	
Serratura INSUBRIA-ATLAS	14.41
<i>Door lock INSUBRIA-ATLAS</i>	
Serratura OTIS	14.44
<i>Door lock OTIS</i>	
Serratura SABIEM	14.41
<i>Door lock SABIEM</i>	
Serratura SCHLIEREN	14.45
<i>Door lock SCHLIEREN</i>	
Serratura SICEM	14.36
<i>Door lock SICEM</i>	

**RICAMBI PER SERRATURE SEMIAUTOMATICHE E A POMOLO, BLOCCHI AZIONAMENTO EMERGENZA
EN81-21**

***SPARE PARTS FOR SEMIAUTOMATIC DOOR LOCKS WITH KNOB, EMERGENCY BLOCK OPERATION
EN81-21***

14 Blocchetto per chiave emergenza per serrature diverse	14.58
<i>Emergency key block for various locks</i>	
Blocco chiave emergenza separato serratura KRONENBERG	14.59
<i>External emergency release by bowden cable for door locks KRONENBERG</i>	

Ricambi per serratura semiautomatica e a pomolo DMG	14.46-14.47-14.48-14.49-14.50
<i>Spare parts for semiautomatic door locks with knob DMG</i>	
Ricambi per serratura semiautomatica e a pomolo FIAM	14.51-14.52-14.53-14.54-14.55-14.56-14.57
<i>Spare parts for semiautomatic door locks with knob FIAM</i>	
Ricambi per serratura semiautomatica KRONENBERG	14.60-14.61
<i>Spare parts for semiautomatic door locks KRONENBERG</i>	
Ricambi per serratura semiautomatica SCHINDLER ORIGINALE	14.62
<i>Spare parts for semiautomatic door locks SCHINDLER original</i>	
Ricambi per serratura semiautomatica TF	14.63-14.64
<i>Spare parts for semiautomatic door locks TF</i>	

Note: I componenti sul catalogo con riportata una specifica marca di ascensore sono utilizzati abitualmente solo da questa marca. I particolari senza marca sono utilizzati da più marche di ascensori.

Note: *The components in the catalogue with a specific lift brand are usually used only by the brand. Unbranded parts are used by multiple lift brands.*

SERRATURA AKRON SEMIAUTOMATICA SEMIAUTOMATIC DOOR LOCKS AKRON



919



919/1



919/3



919/4

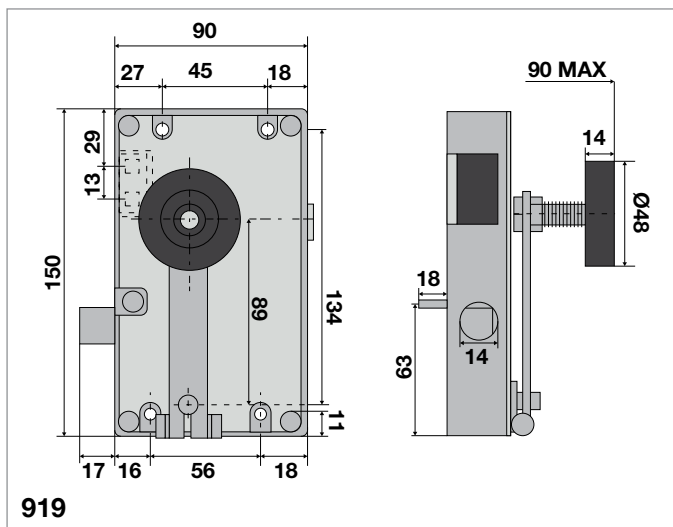

919

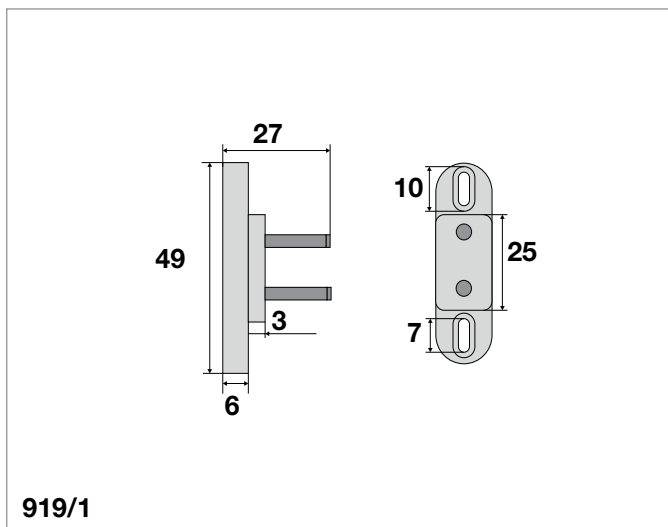

919/1

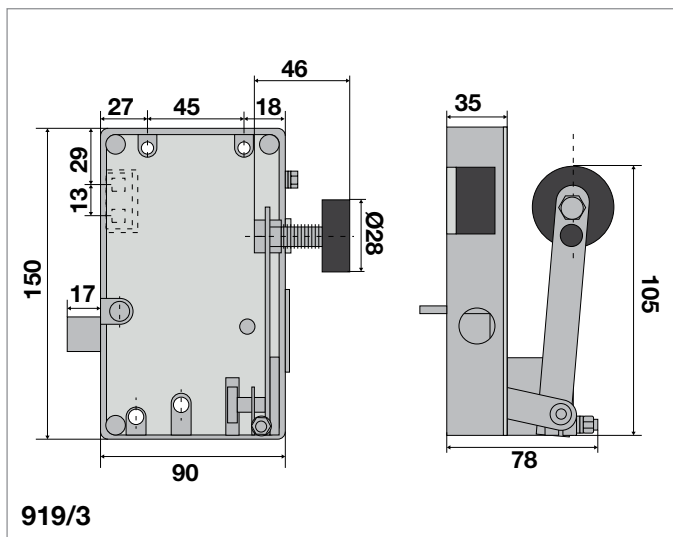

919/3

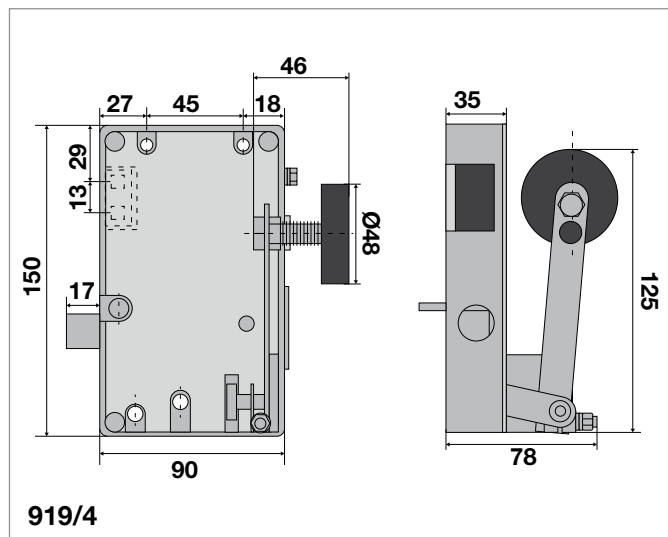

919/4

Codice / Code	Descrizione
919	Serratura certificata semiautomatica a movimento laterale standard per ascensori AKRON rotella diametro 48 mm completa di ponte cod.919/1
919/1	Ponte per serratura AKRON
919/3	Serratura omologata semiautomatica a movimento perpendicolare standard per ascensori AKRON rotella diametro 28 mm
919/4	Serratura omologata semiautomatica a movimento perpendicolare standard per ascensori AKRON rotella diametro 48 mm

SERRATURA BASSETTI SEMIAUTOMATICA SEMIAUTOMATIC DOOR LOCKS BASSETTI



997



997/A

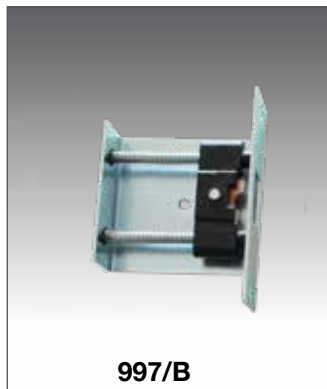

997/B



997/C

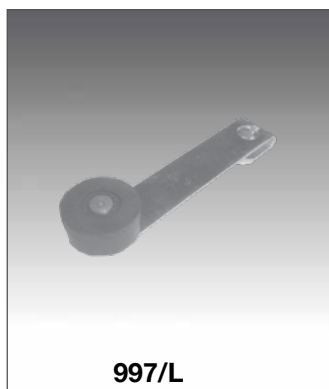

997/L

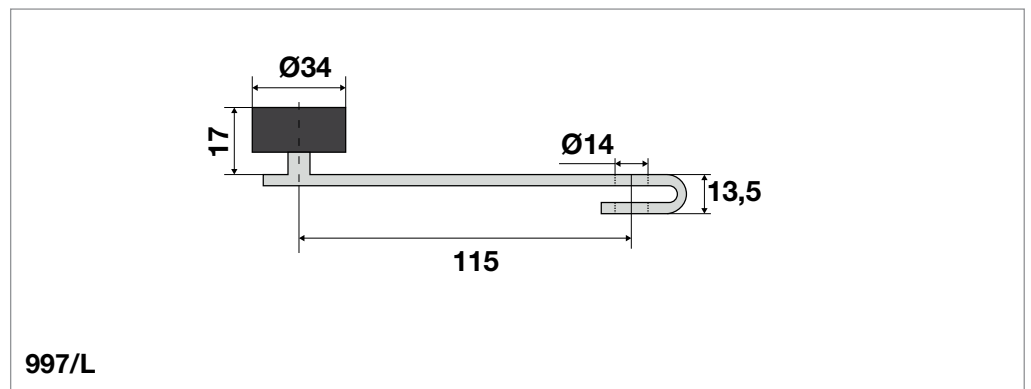

997/L

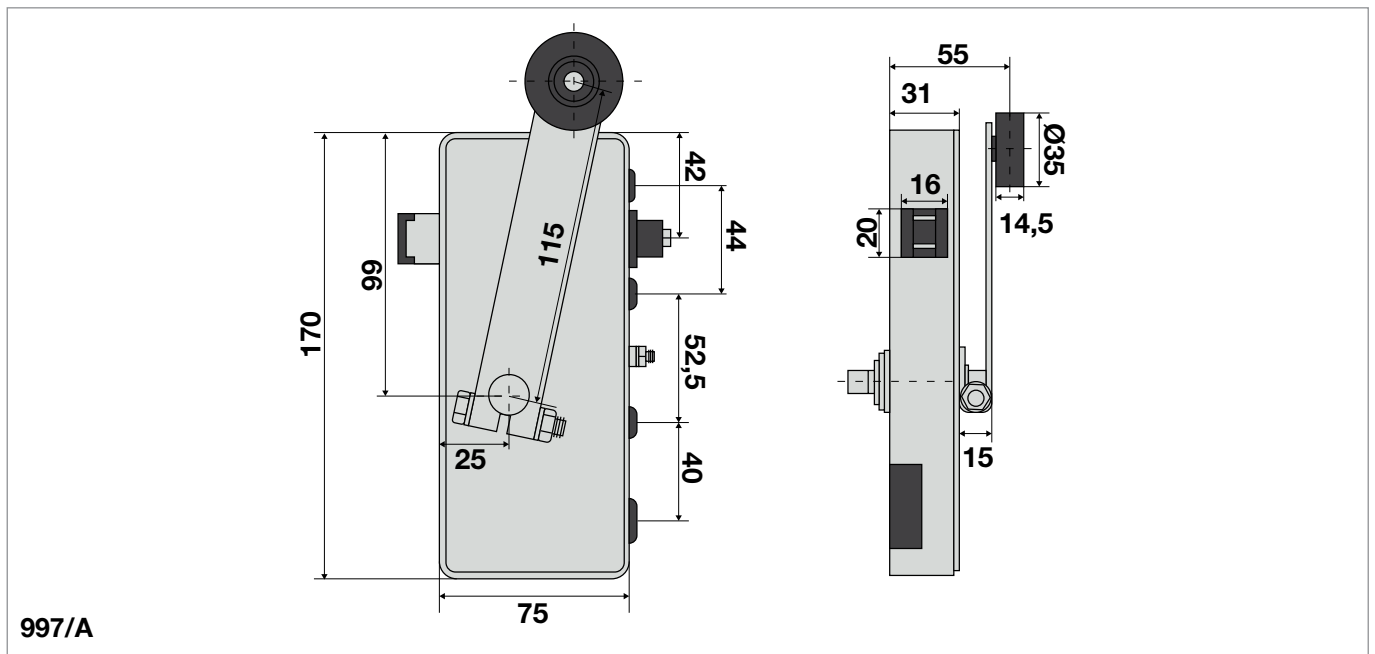

997/A

Codice / Code	Descrizione
997	Serratura semiautomatica omologata BASSETTI
997/A	Porte elettrica serratura semiautomatica omologata BASSETTI cod.997
997/B	Parte mobile serratura semiautomatica omologata BASSETTI cod.997
997/C	Ponte asportabile serratura semiautomatica omologata BASSETTI cod.997
997/L	Leva con rotella serratura semiautomatica omologata BASSETTI cod.997

SERRATURE SEMIAUTOMATICHE SEMI-AUTOMATIC DOOR LOCKS



950



950L



950M



991K

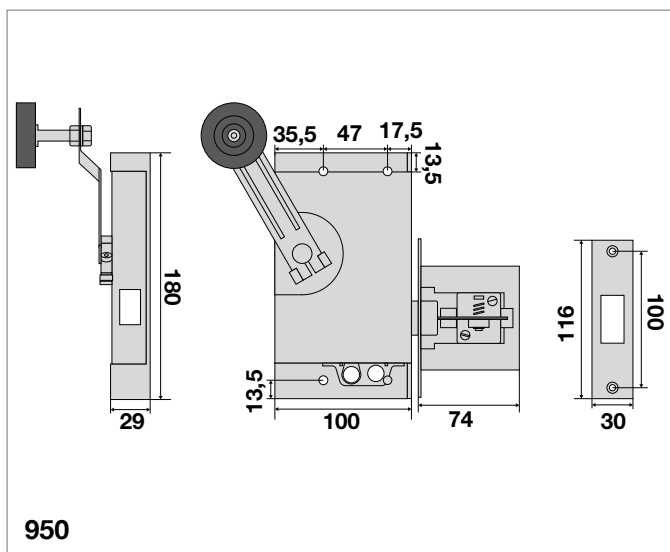

950

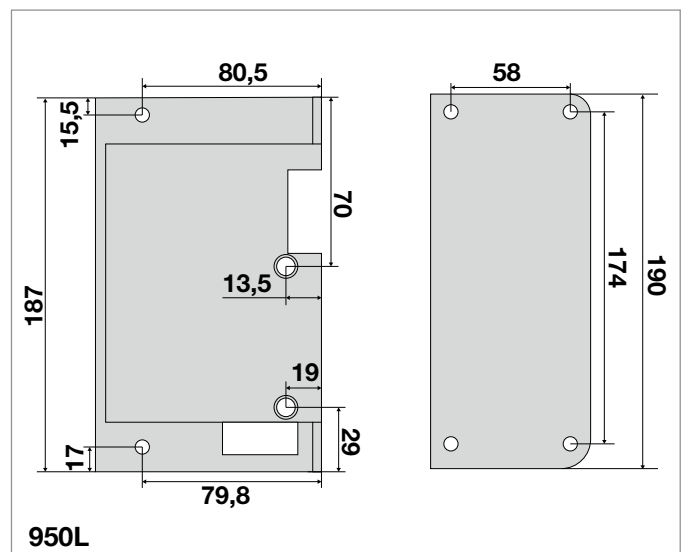

950L

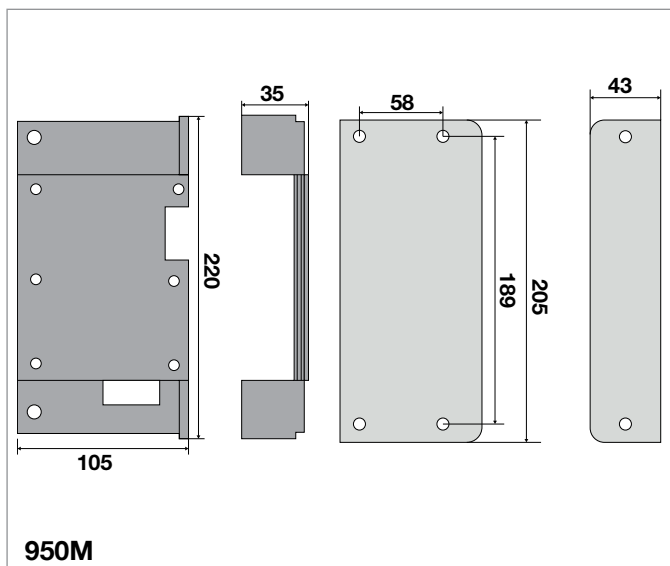

950M

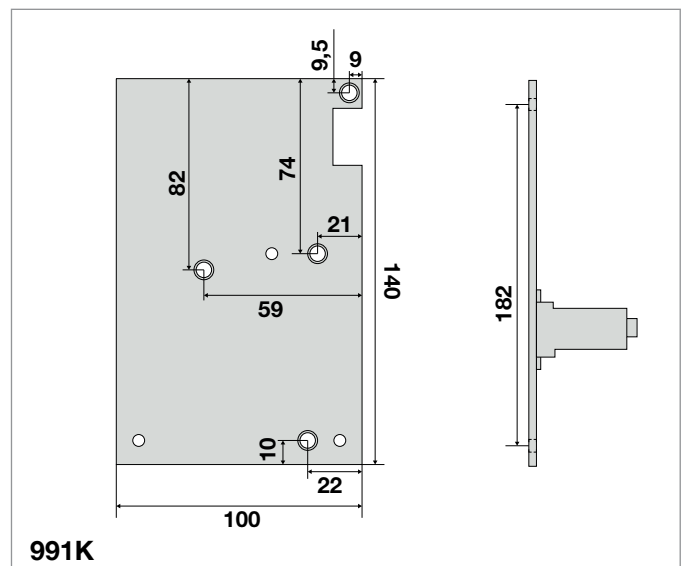

991K

N.B. Disegnati kit anche con sole piastre singole. Ogni kit comprende serratura con leva e contatto.

Codice / Code	Descrizione
950	Kit sostituzione serratura BONFEDI semiautomatica omologata
950L	Kit sostituzione serratura CIOCCA semiautomatica tipo vecchio
950M	Kit sostituzione serratura CIOCCA semiautomatica nuovo tipo
991K	Kit sostituzione serratura DALLAGIOVANNA semiautomatica omologata

SERRATURE SEMIAUTOMATICHE SEMI-AUTOMATIC DOOR LOCKS



906/1



900/1



901/1



902/1



950N

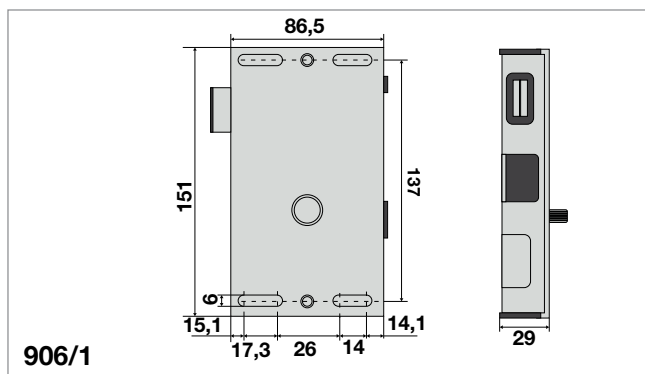

906/1

N.B. Disegnati kit anche con sole piastre singole. Ogni kit comprende serratura con leva e contatto.

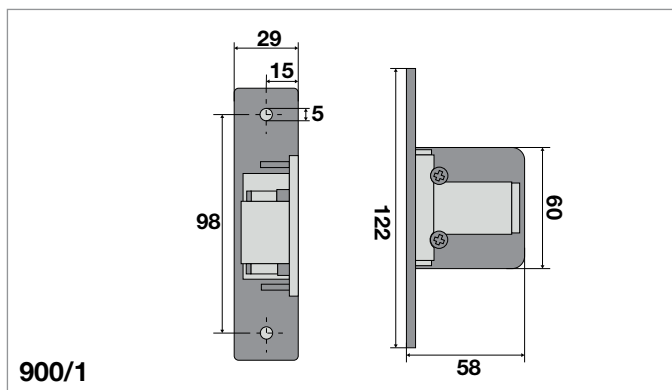

900/1

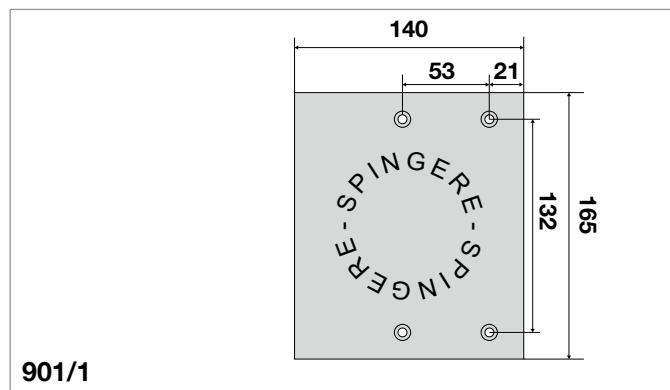

901/1

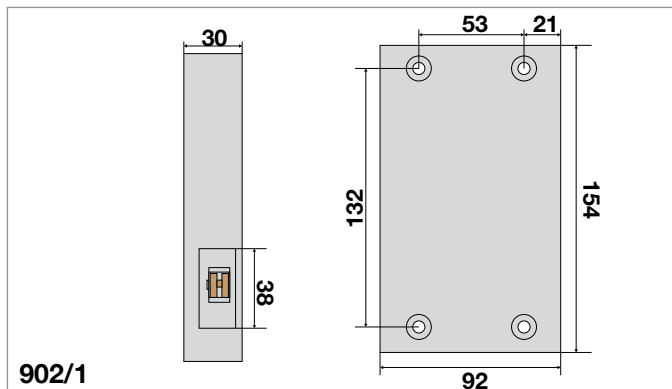

902/1

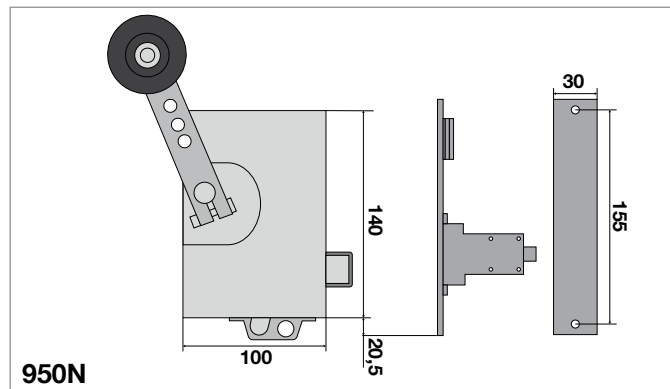

950N

Codice / Code	Descrizione
906/1	Parte elettrica omologata serratura DMG (questa parte elettrica è adatta per serrature manuali e semiautomatiche)
900/1	Parte meccanica ad incasso serratura DMG
901/1	Parte meccanica a spingere ad incasso serratura DMG
902/1	Parte meccanica sovrapposta serratura DMG
950N	Kit sostituzione serratura FEMER semiautomatica

SERRATURE SEMIAUTOMATICHE SEMI-AUTOMATIC DOOR LOCKS

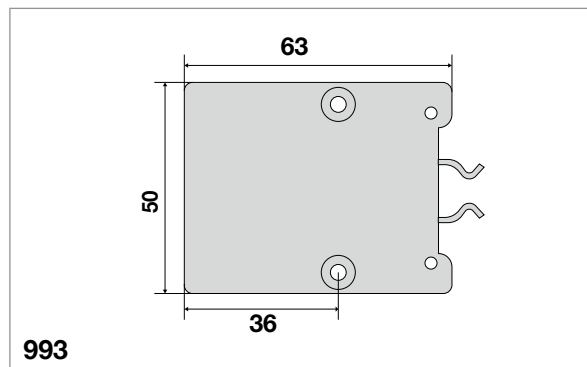

N.B. Disegnati kit anche con sole piastre singole. Ogni kit comprende serratura con leva e contatto.

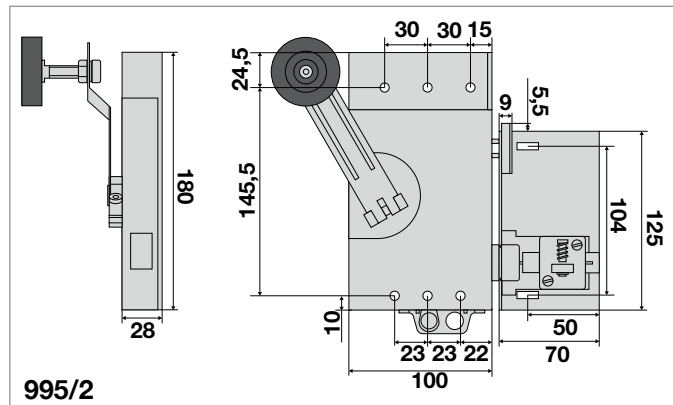
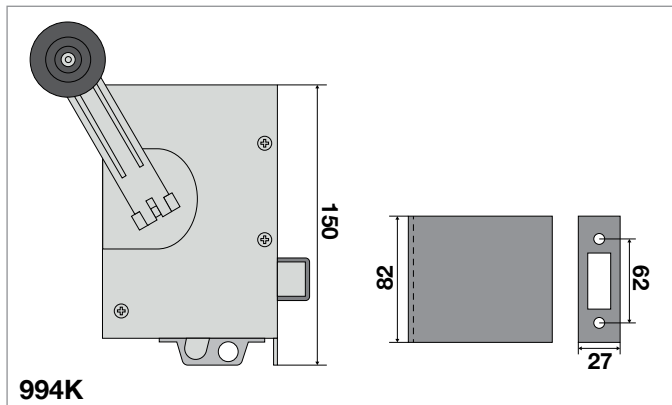
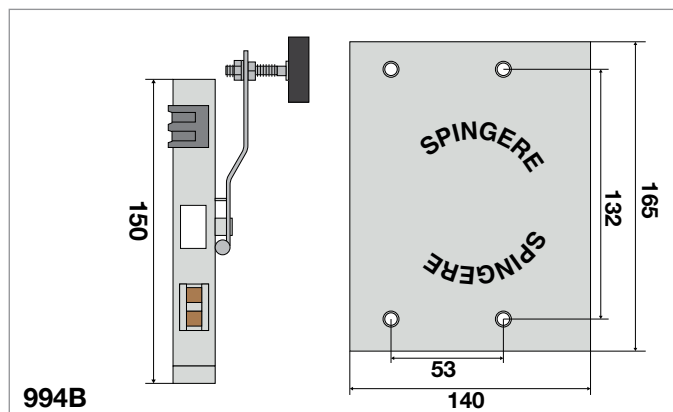
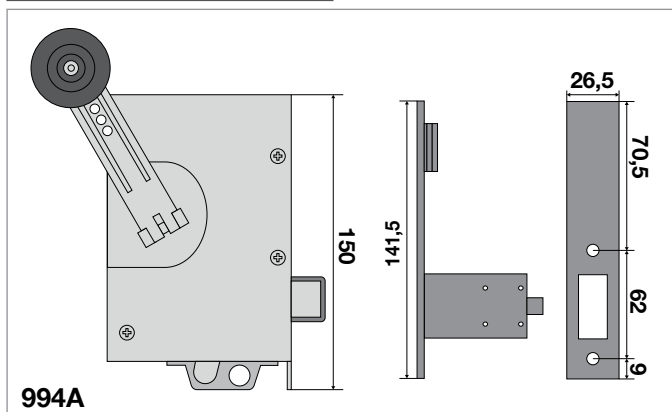

Codice / Code	Descrizione
993	Contatto parte mobile serratura FORSID-MONITOR
994A	Kit sostituzione serratura FORSID-MONITOR premontata omologata
994B	Kit sostituzione serratura FORSID-MONITOR semiautomatica con piastra spingere
994K	Kit sostituzione serratura FORSID-MONITOR semiautomatica omologata
995/2	Kit sostituzione serrature FALCONI semiautomatiche omologate

SERRATURE SEMIAUTOMATICHE SEMI-AUTOMATIC DOOR LOCKS

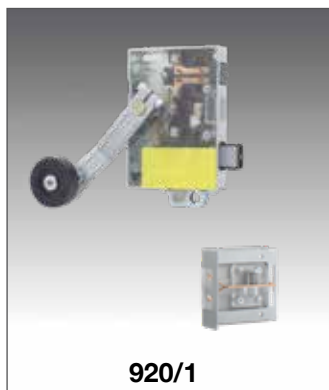

920/1

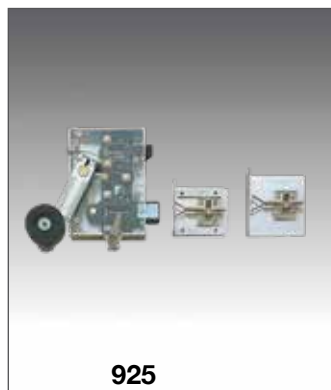

925



926

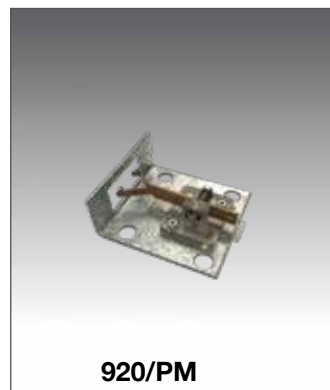

920/PM

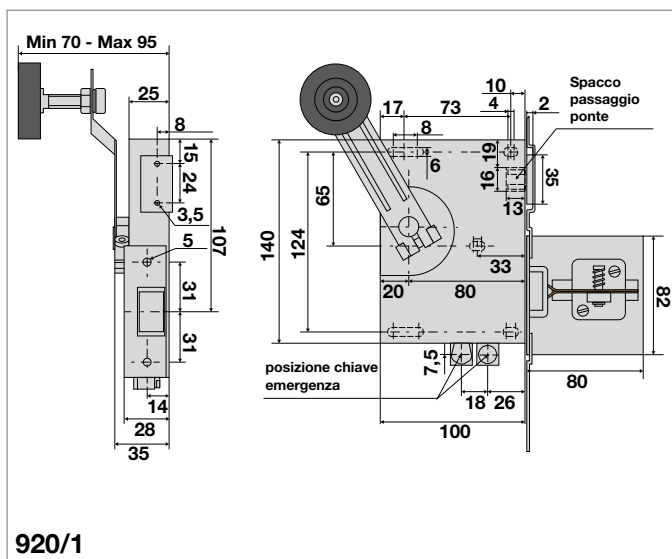

920/1

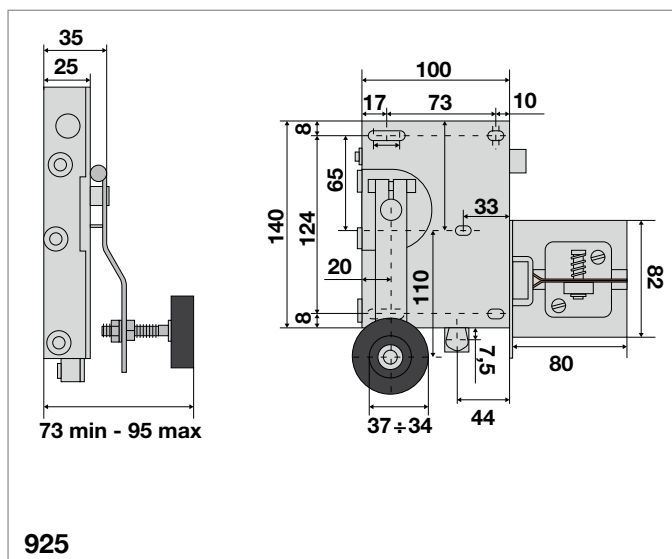

925

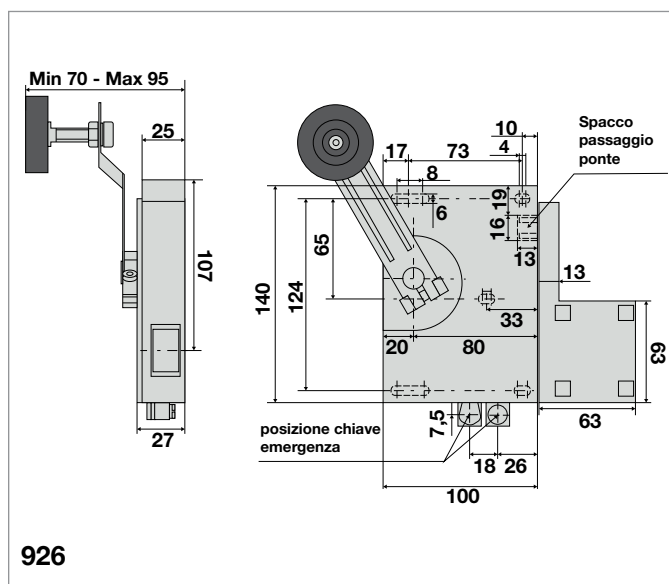

926

Codice / Code	Descrizione
920/1	Serratura semiautomatica omologata EN81 IMQ FIAM
925	Serratura semiautomatica con emergenza FIAM non omologata
926	Serratura semiautomatica omologata FIAM premontata
920/PM	Solo parte mobile serratura semiautomatica FIAM

SERRATURE SEMIAUTOMATICHE SEMI-AUTOMATIC DOOR LOCKS



928K



950E



950F

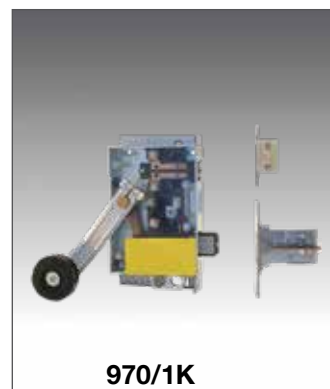

970/1K

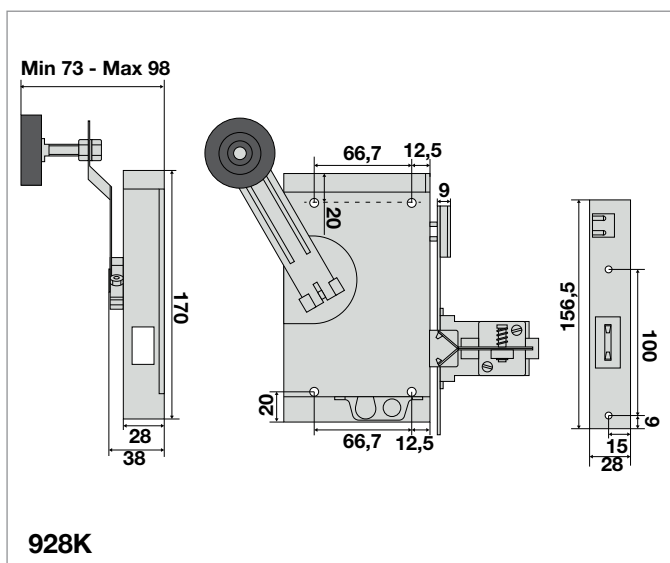

928K

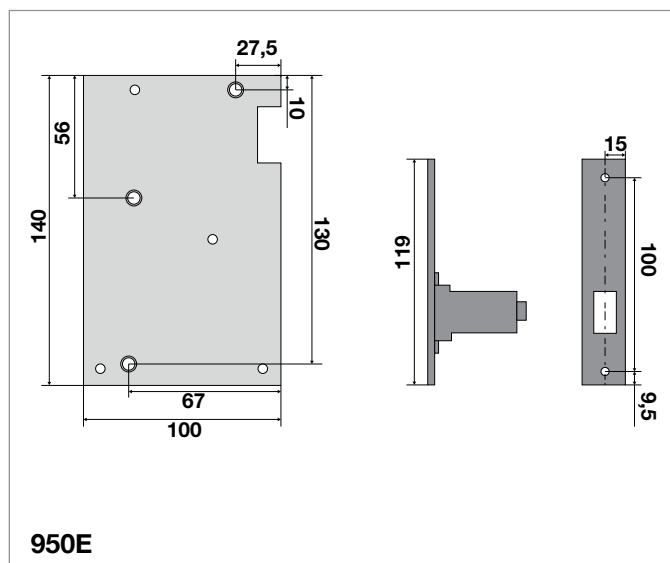

950E

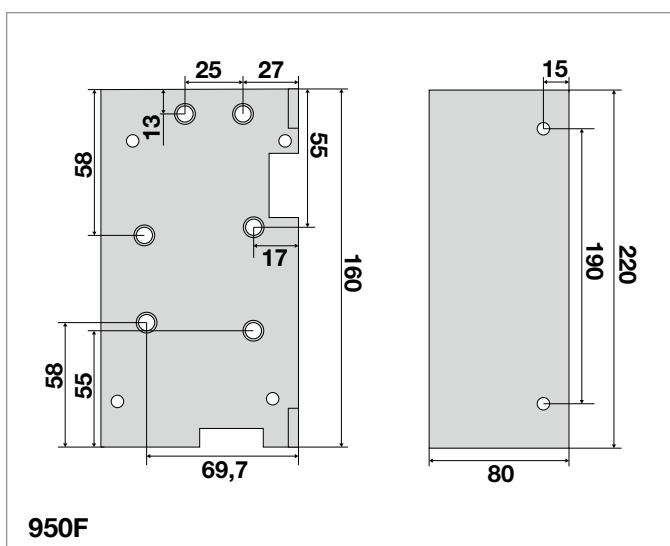

950F

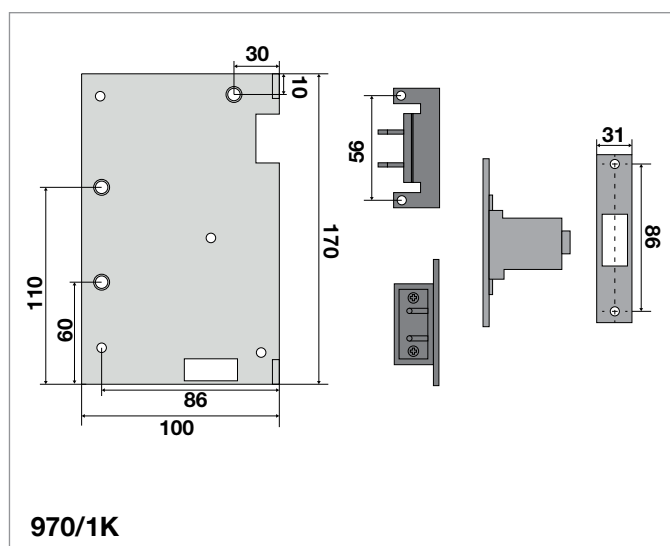

970/1K

14

N.B. Disegnati kit anche con sole piastre singole. Ogni kit comprende serratura con leva e contatto.

Codice / Code	Descrizione
928K	Kit sostituzione serratura INSUBRIA-ATLAS semiautomatica omologata
950E	Kit sostituzione serratura ROCE semiautomatica omologata
950F	Kit sostituzione serratura FURINI semiautomatica
970/1K	Kit sostituzione serratura TESIO semiautomatica omologata

SERRATURE KRONENBERG KRONENBERG DOOR LOCKS

Importante

Sulle pagine successive altri modelli e varianti

Vi indichiamo un metodo semplice per ordinazione foto + misura a pagina 14.18

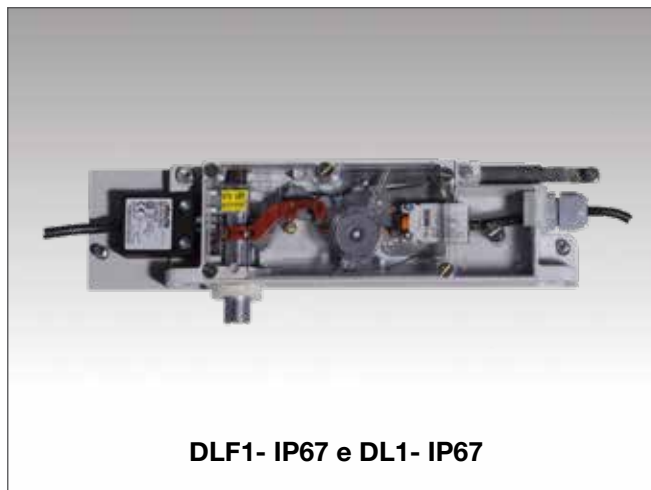
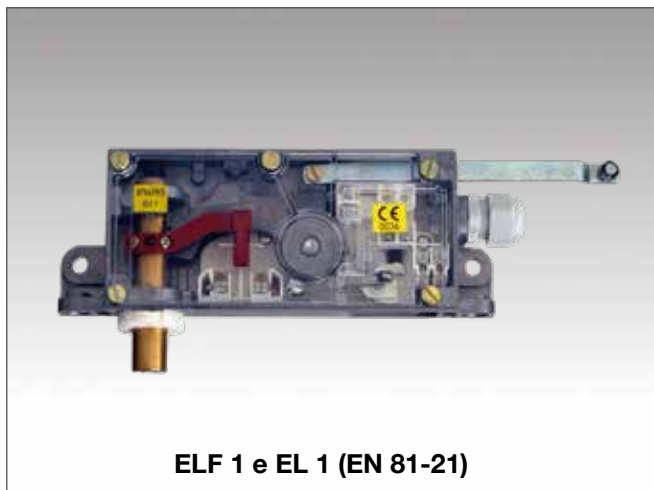
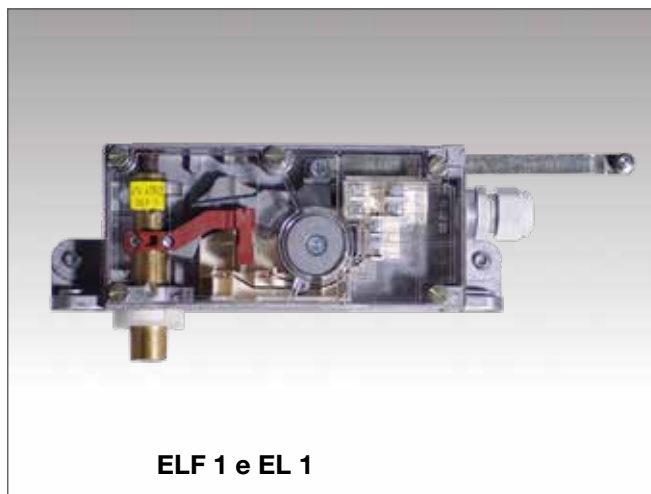
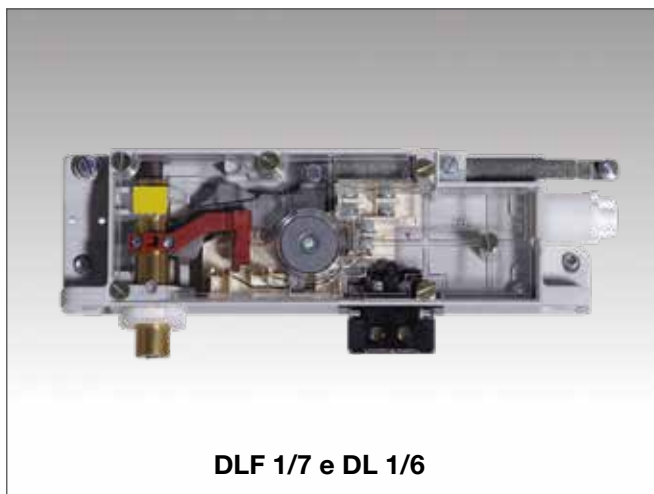
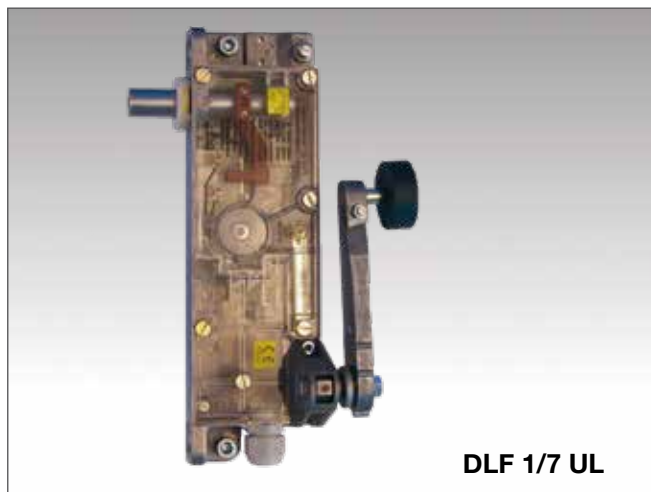

SERRATURE KRONENBERG KRONENBERG DOOR LOCKS

Importante

Sulle pagine successive altri modelli e varianti

Vi indichiamo un metodo semplice per ordinazione foto + misura a pagina 14.18

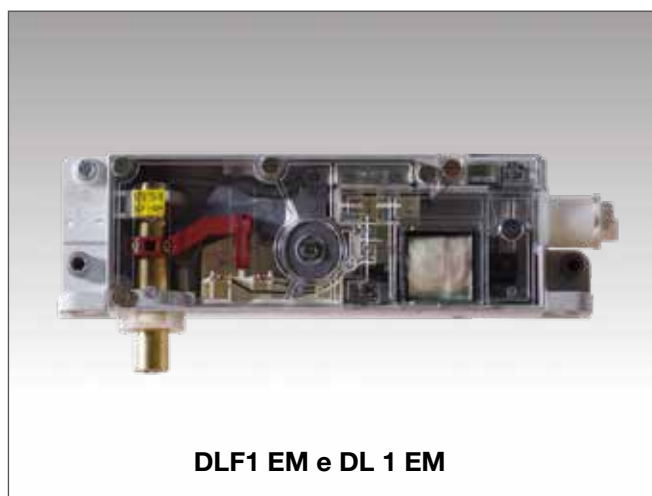
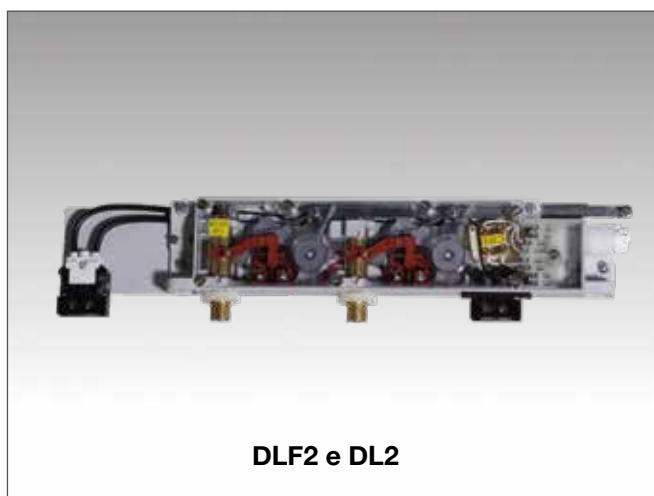

VARIANTI PER ORDINARE KRONENBERG DLF 1/7 E DL 1/6
VARIOUS TO ORDER KRONENBERG DLF 1/7 AND DL 1/6

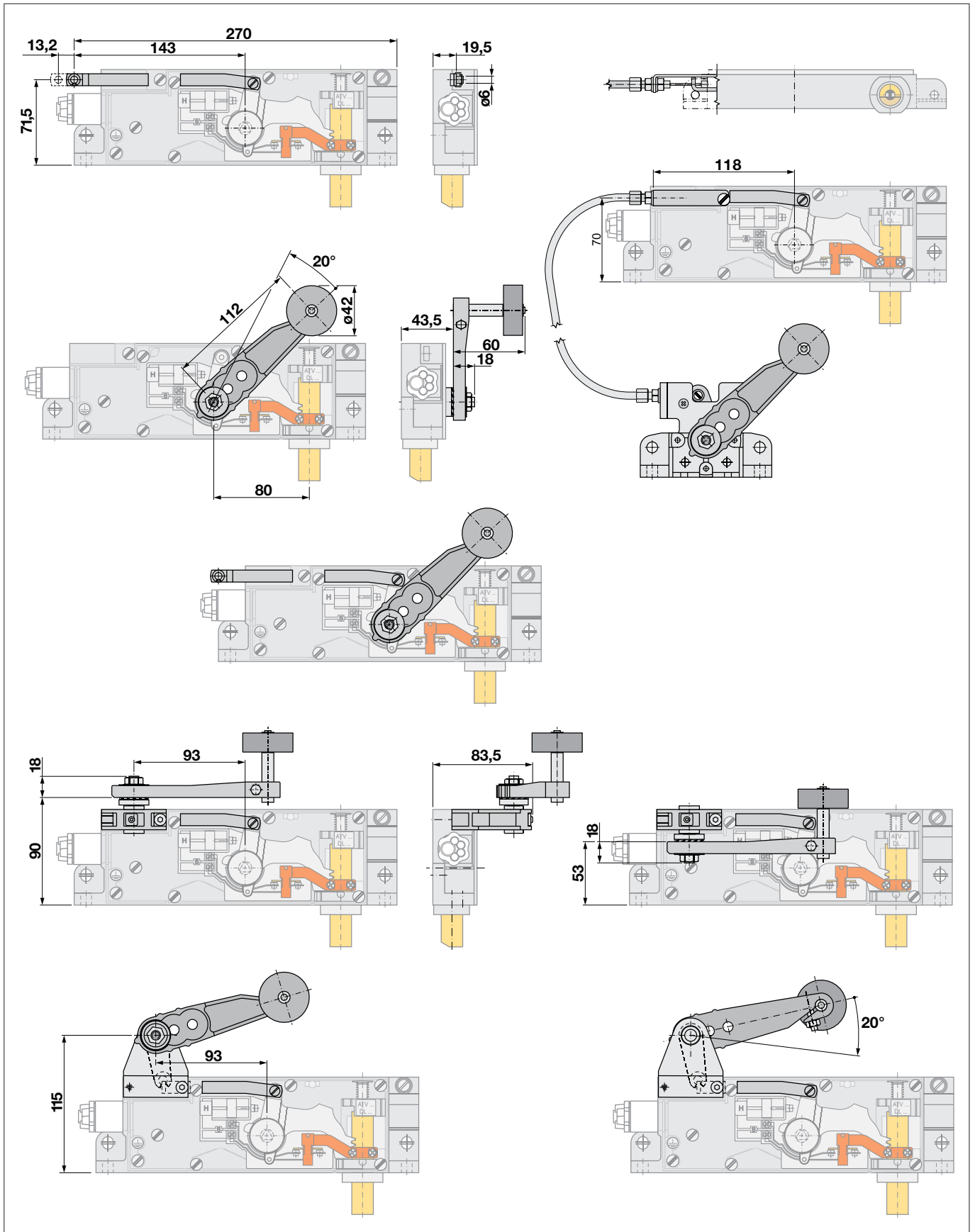

VARIANTI PER ORDINARE KRONENBERG DLF 1/7 UL
VARIOUS TO ORDER KRONENBERG DLF 1/7 UL

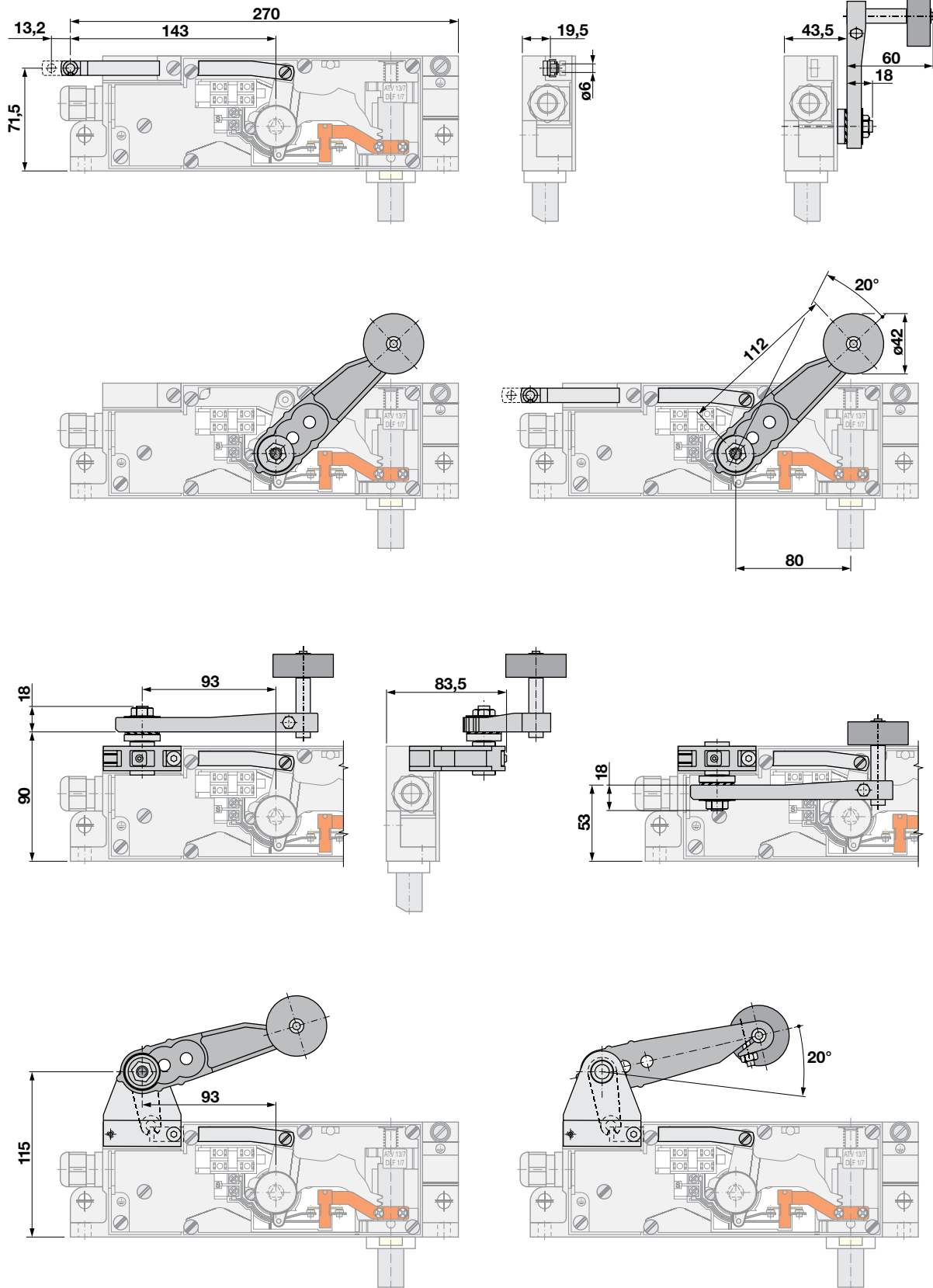

VARIANTI PER ORDINARE KRONENBERG DLF 2 E DL 2
VARIOUS TO ORDER KRONENBERG DLF 2 AND DL 2

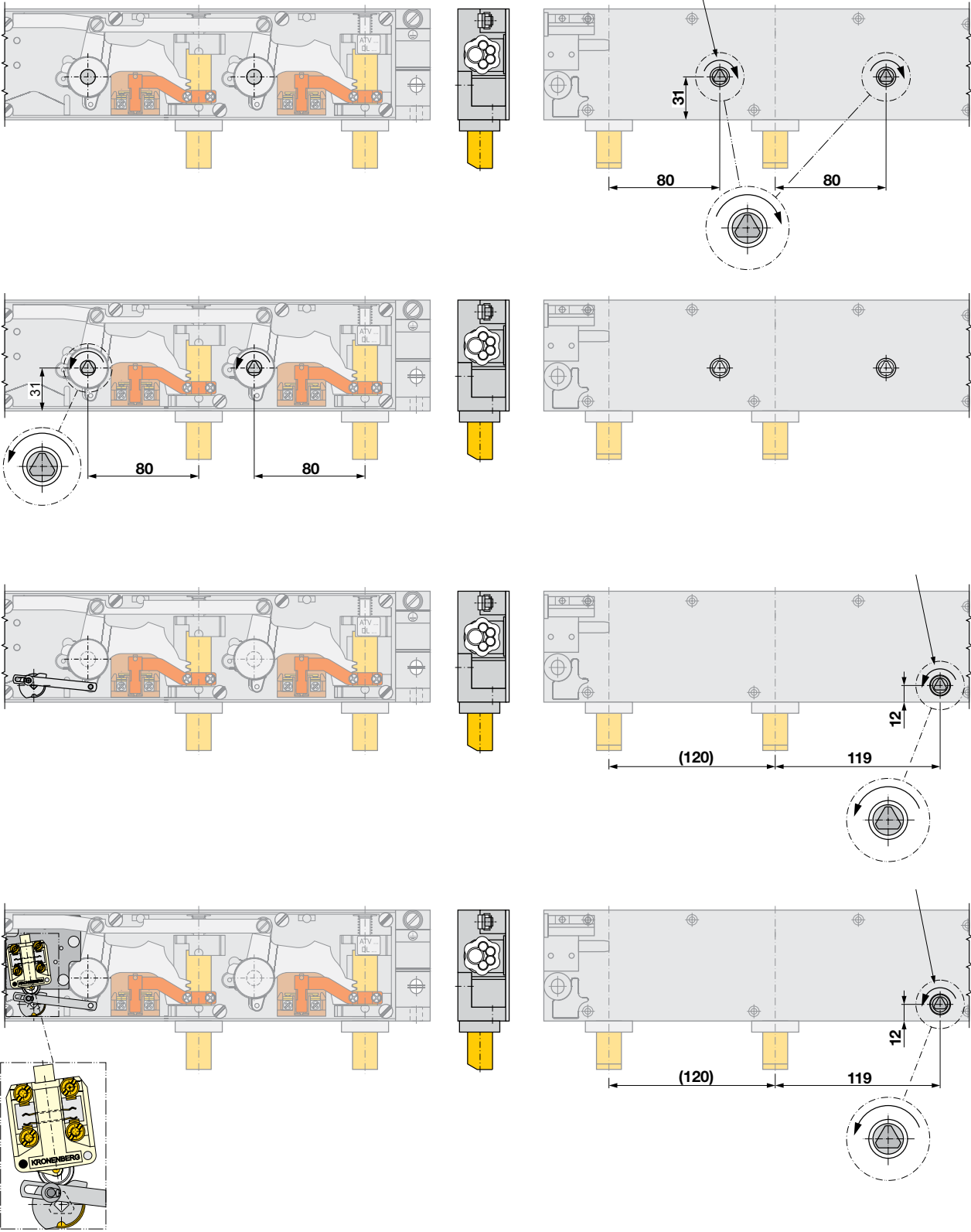

**SERRATURE KRONENBERG PER ORDINARE LE SERRATURE INVIARE: FOTO E INDICARE MISURA L OPPURE LA MISURA X
TO ORDER KRONENBERG DOOR LOCK: SENDING PHOTO OF DIMENSION L OR X**

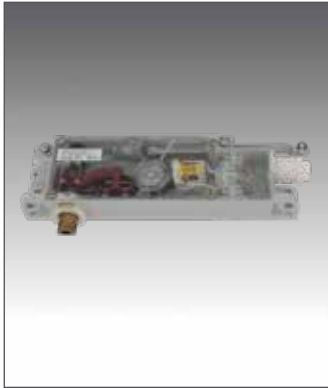

Tutte le serrature KRONENBERG hanno etichetta con codice sul lato opposto al perno.
Comunicateci il codice o meglio inviateci foto dell'etichetta e della serratura, Vi comunicheremo prezzo e tempo di consegna.
Attenzione!! Può succedere che le serrature sono state modificate. Per essere certi comunicateci almeno una delle 3 quote richieste L - P o X. esempio tipo DL con perno pieno a DLF perno con spina e smusso.
Esempio valido anche per serrature a 2 perni.

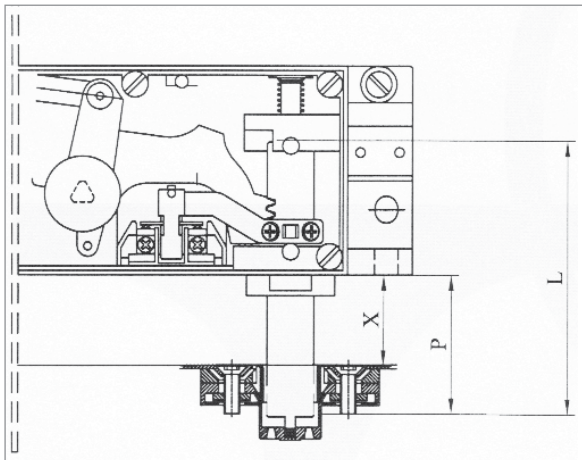

Importante
L = misura totale del perno in caso di serratura W stagno smontare il coperchio

L = _____
P = _____
X = _____
Indicare almeno una quota

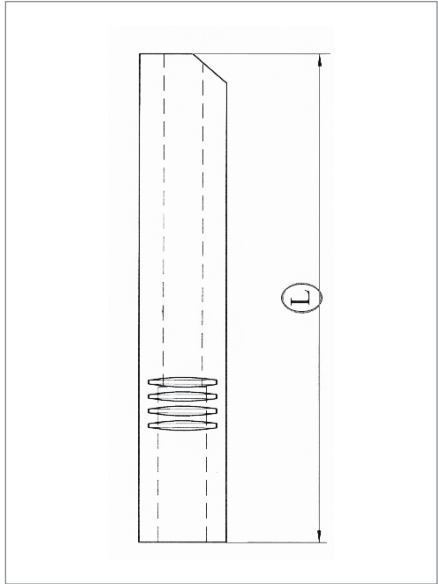

X Distance from lock to leaf (Distanza da serratura a battente porta)	Aperto P (P = X + 21) Open	Lunghezza tot. L (L = X + 70) Total Length
10	31	80
15	36	85
20	41	90
30	51	100
40	61	110
100	121	170

SERRATURE SEMIAUTOMATICHE SEMI-AUTOMATIC DOOR LOCKS

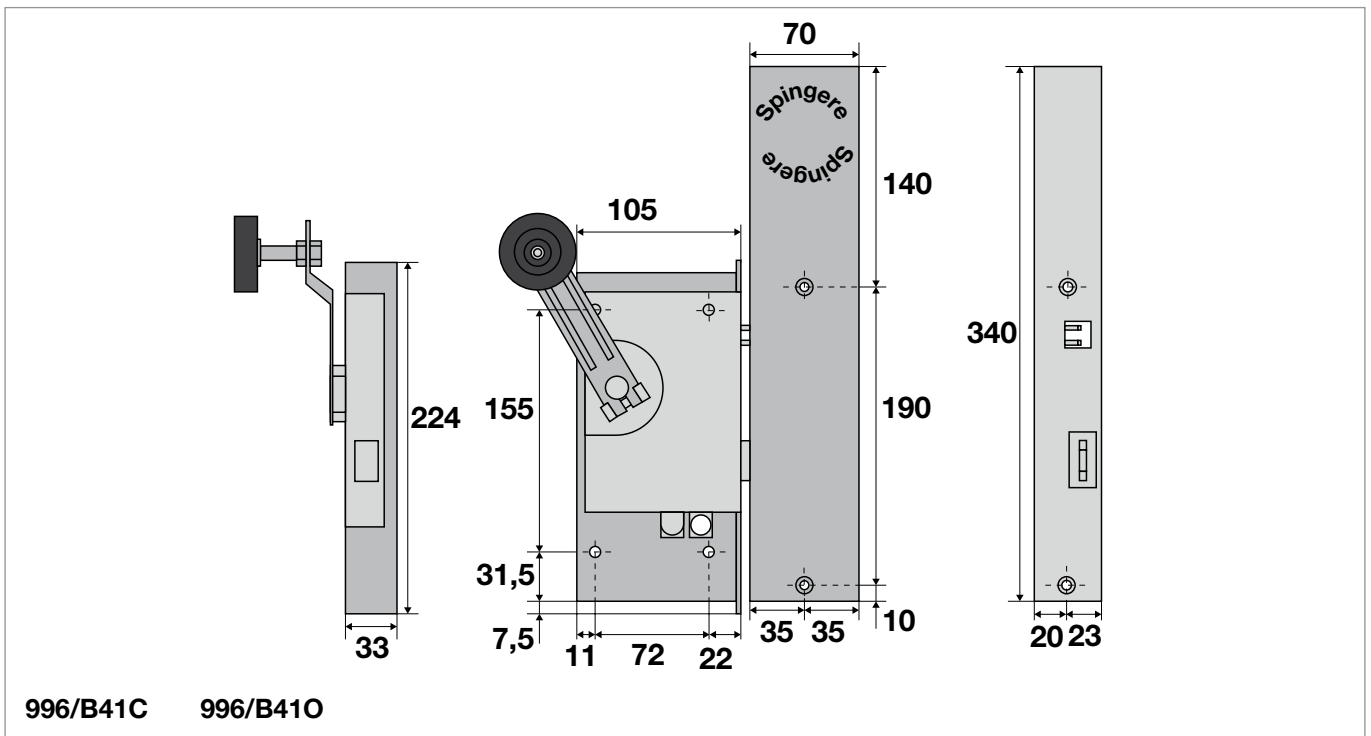
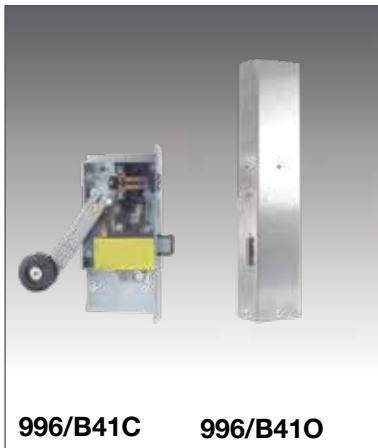

N.B. Disegnati kit anche con sole piastre singole. Ogni kit comprende serratura con leva e contatto.

Codice / Code	Descrizione
996/B41C	Kit sostituzione serratura OTIS B41 - B55 semiautomatica cromata
996/B41O	Kit sostituzione serratura OTIS B41 - B55 semiautomatica ottonata

SERRATURA ELETTRICA LR128E CERTIFICATA EN81 ELECTRICAL DOOR LOCK LR128E CERTIFIED EN81

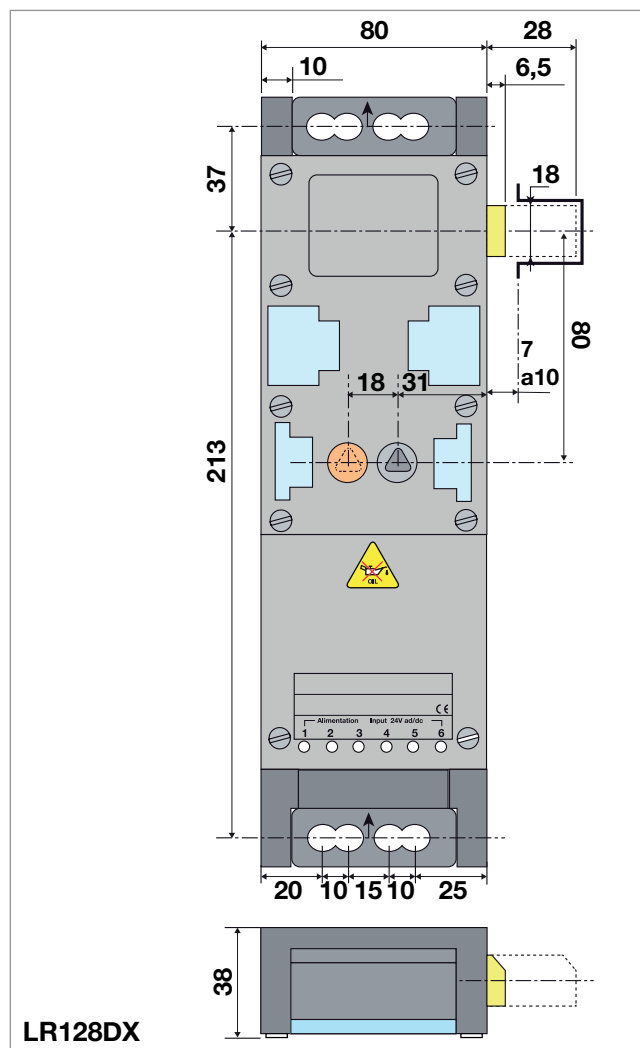

La serratura elettrica LR128E elimina l'installazione del pattino retrattile con relativo elettromagnete, avendo un elettromagnete interno azionante il catenaccio.

Raffigurata serratura elettrica LR128E versione DX codice LR128DX con riscontro GV

The electric door lock LR128E eliminates the installation of the retractable cam with electromagnet having an electromagnet inside the deadbolt actuating.

Represented electric door lock LR128E version RX code LR128DX with movable section GV

Dati tecnici		Assorbimento	
Alimentazione (voltage)	24Vcc/CA*10%	Dopo lo spunto (after verification)	150mA (24V) 50mA (48V)
Assorbimento spunto (power consumption)	4,5A (24V)	Frequenza tensione (voltage frequently)	50/60Hz
		Inserzione (Duty cycles)	100% oraria
	3A (48V)	Cicli di funzionamento (cycles of working cycles)	max. 120 ora
		Portata contatto blocco (Contact capacity block)	2A / 230V
		Portata contatto presente (Contact capacity present)	2A / 230V

Funzionamento

Chiudendo il circuito di alimentazione dell'elettromagnete, il catenaccio si ritrae
Closing the power circuit of the electromagnet, the bolt retracts

Codice / Code	Descrizione
LR128DX	Serratura destra
LR128SX	Serratura sinistra
GV	Riscontro
GVR	Riscontro per montaggio su porte non predisposte

SERRATURE CERTIFICATE PER SOSTITUZIONE SERRATURE OTIS FCO 9538B
CERTIFICATED DOOR LOCK FOR REPLACEMENT DOOR LOCK OTIS
FCO 9538B



LR180PD



LR180PG

Serratura certificata per sostituzione serrature semiautomatiche OTIS con movimento perpendicolare tipo FCO 9538B

The certificated door lock for replacement of OTIS semiautomatic door locks with perpendicular movement type FCO 9538B

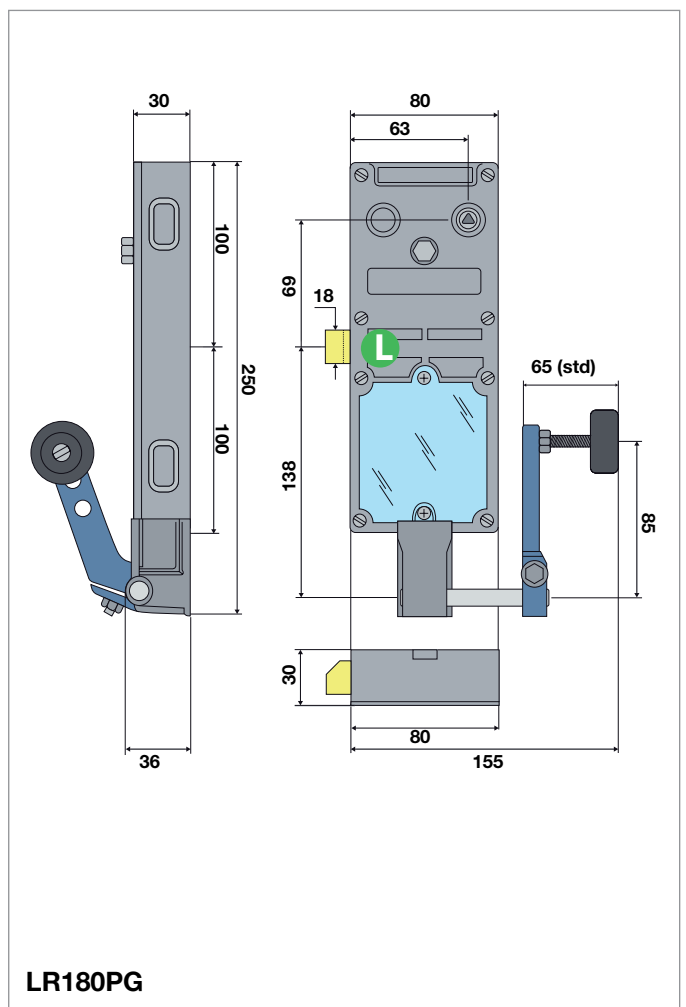
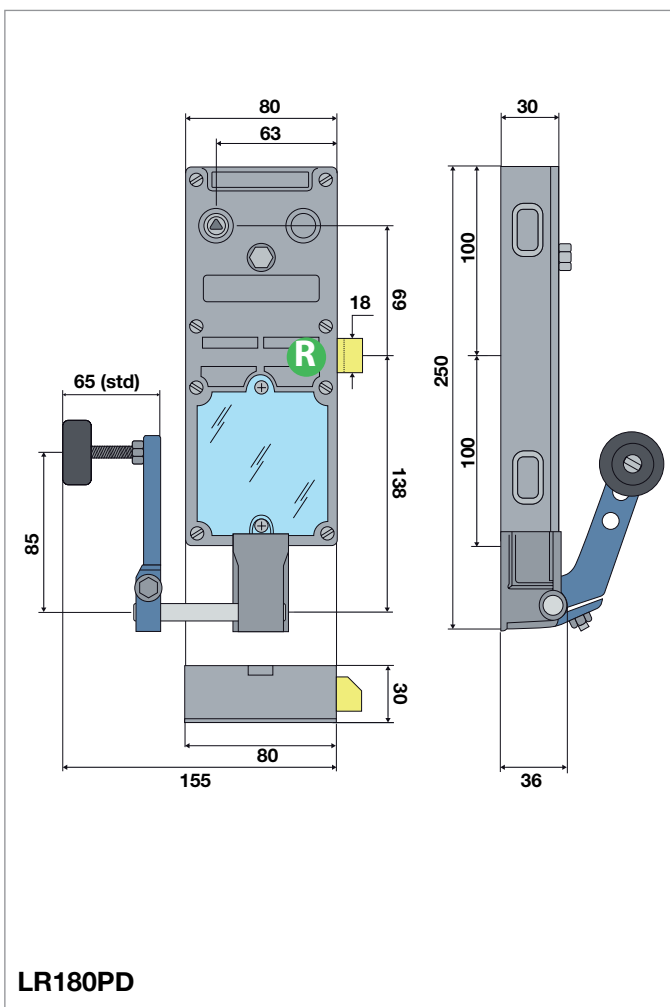

Codice / Code	Descrizione
LR180PD	Kit completo di serratura destra ed accessori
LR180PG	Kit completo di serratura sinistra ed accessori
CP/DV	Dima ambidestra per forature serratura OTIS non raffigurata
CP180	Set dime per foratura destra e sinistra serratura OTIS non raffigurata

SERRATURE CERTIFICATE PER SOSTITUZIONE SERRATURE OTIS FCO 9538A CERTIFICATED DOOR LOCK FOR REPLACEMENT DOOR LOCK OTIS FCO 9538A



Serratura certificata per sostituzione serrature semiautomatiche OTIS con movimento laterale tipo FCO 9538A

The certified door lock for replacement of OTIS semiautomatic door locks with lateral movement type FCO 9538A

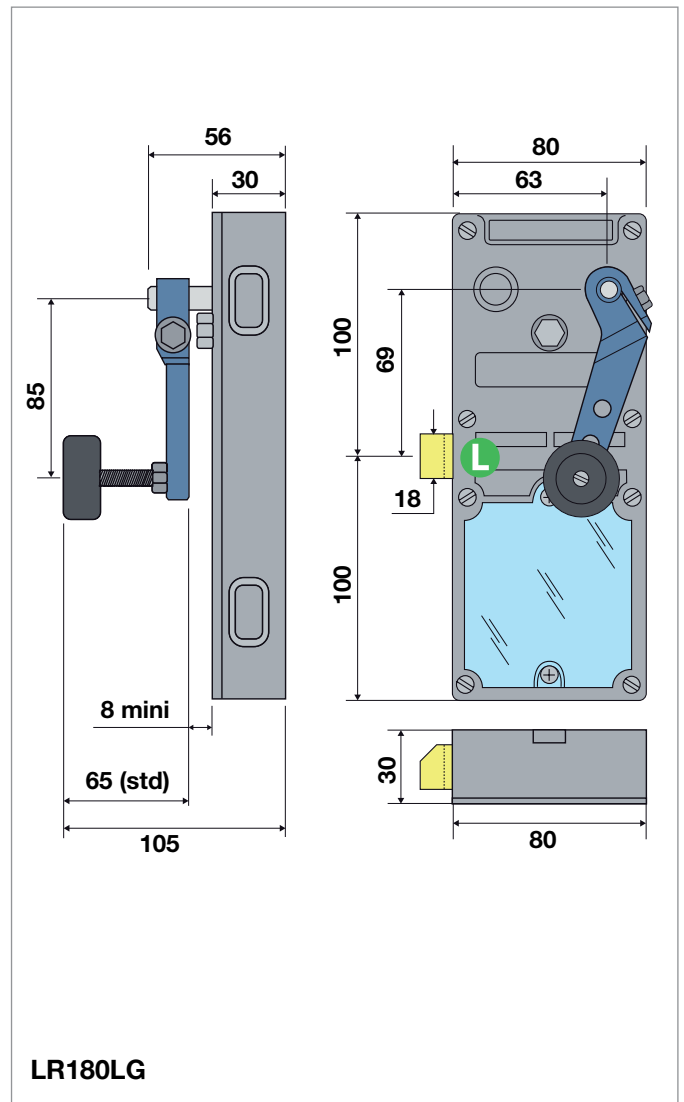
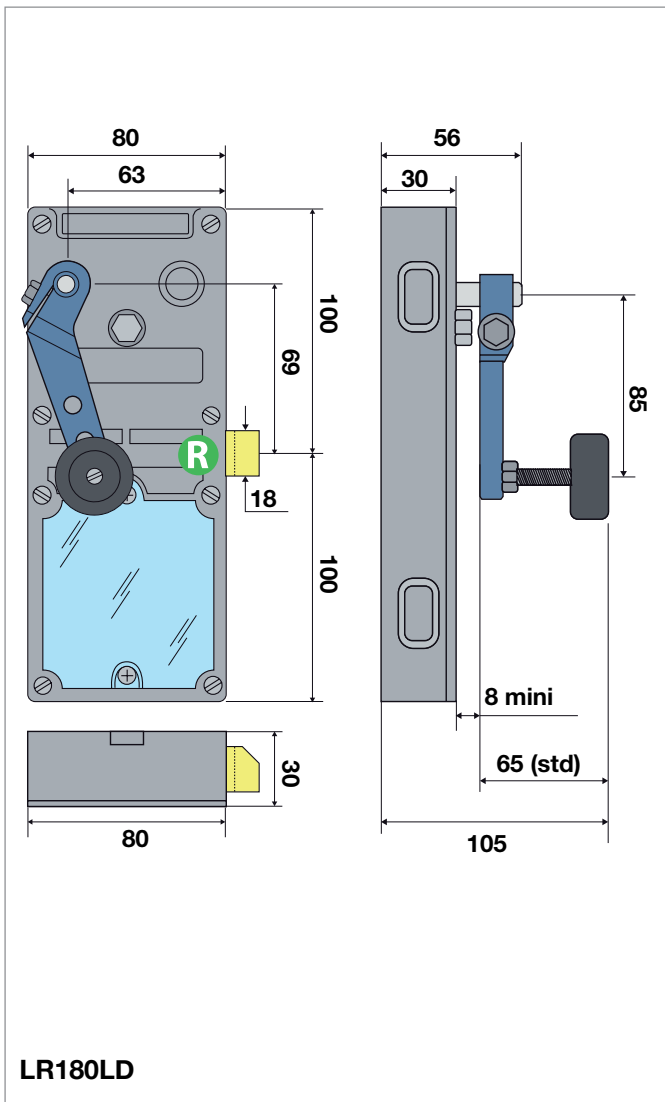

Codice / Code	Descrizione
LR180LD	Kit completo di serratura destra ed accessori
LR180LG	Kit completo di serratura sinistra ed accessori

SERRATURE CERTIFICATE PER SOSTITUZIONE SERRATURA SCHINDLER HE1/HE2
CERTIFICATED DOOR LOCK FOR REPLACEMENT DOOR LOCK SCHINDLER HE1/HE2



Serratura semiautomatica certificata per sostituzione serrature SCHINDLER HE1/HE2

Disponibile su ordinazione serrature originali SCHINDLER non certificate

The certificated semiautomatic door lock for replacement of SCHINDLER door locks HE1/HE2

The original SCHINDLER door lock is available on request, but not certified

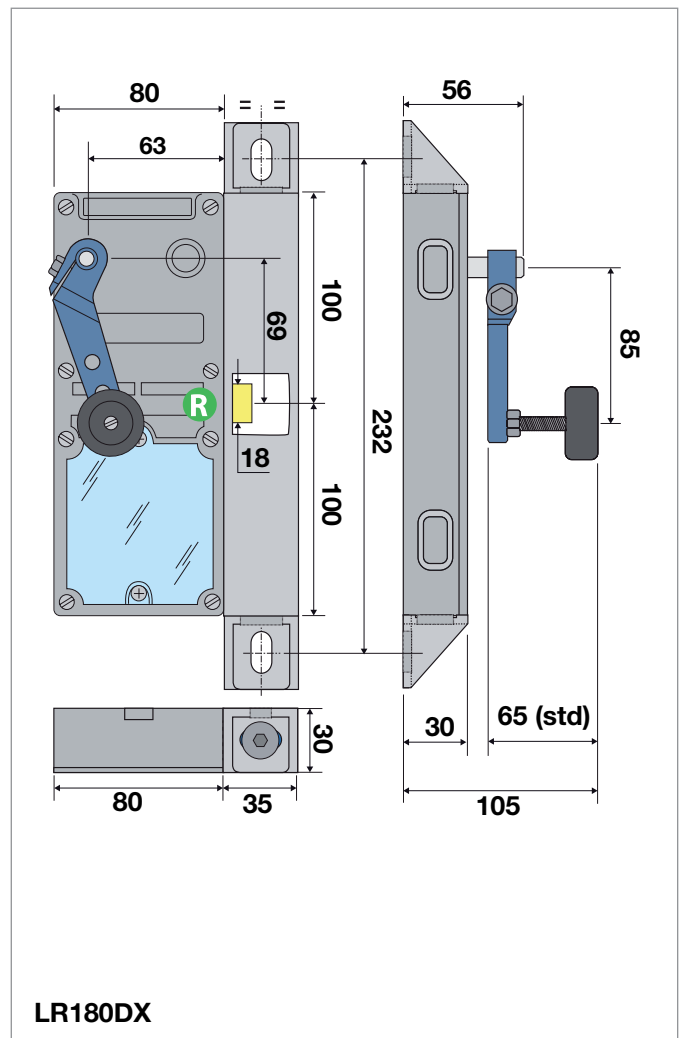
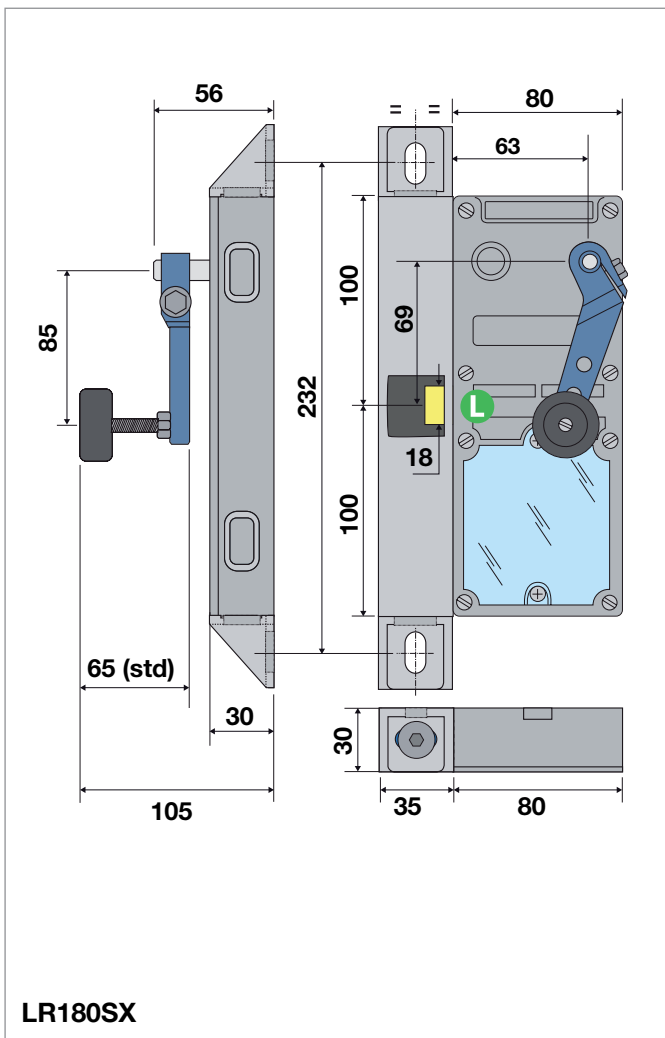

Codice / Code	Descrizione
LR180SX	Kit completo di serratura sinistra ed accessori
LR180DX	Kit completo di serratura destra ed accessori
CP/DV	Dima ambidestra per forature serratura SCHINDLER non raffigurata

SERRATURE CERTIFICATE INTERCAMBIABILI SABIEM CERTIFIED SABIEM INTERCHANGEABLE DOOR LOCK



LR190LG



LR190LD

Serratura certificata per sostituzione serrature diverse per ascensori SABIEM

Certified door lock for replacing different door locks in SABIEM lift

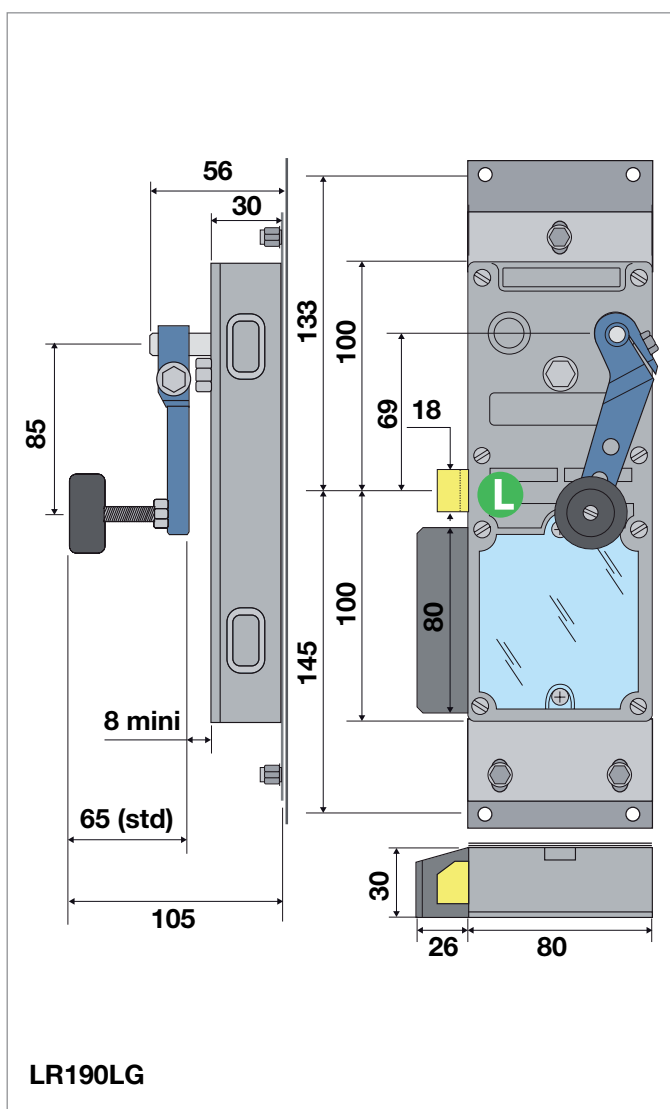

LR190LG

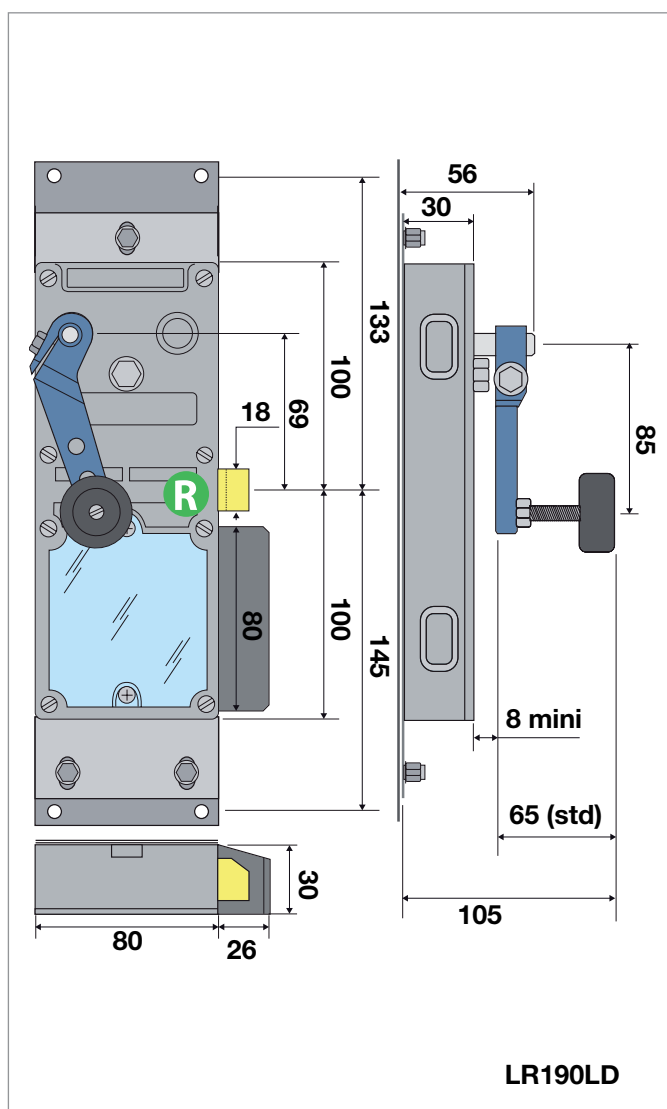

LR190LD

Codice / Code	Descrizione
LR190LG	Kit completo con serratura sinistra, accessori e contatto di accostamento
LR190LD	Kit completo con serratura destra, accessori e contatto di accostamento

SERRATURE SAFOV SEMIAUTOMATICHE SAFOV SEMIAUTOMATIC DOOR LOCKS



Accessori per porte ferro

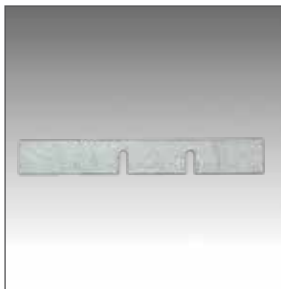

Accessori per porte legno

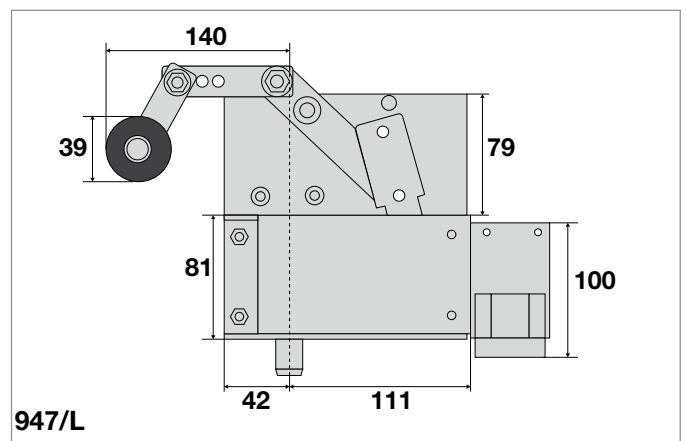
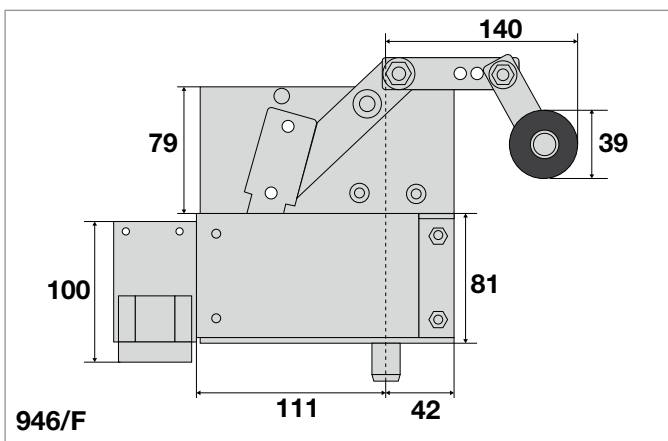
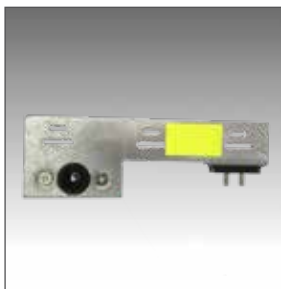

Codice / Code	Descrizione
946/F	Serratura omologata EN81 intercambiabile senza modifiche su ascensori SAFOV per porte in ferro destra
946/L	Serratura omologata EN81 intercambiabile senza modifiche su ascensori SAFOV per porte in legno destra
947/F	Serratura omologata EN81 intercambiabile senza modifiche su ascensori SAFOV per porte in ferro sinistra
947/L	Serratura omologata EN81 intercambiabile senza modifiche su ascensori SAFOV per porte in legno sinistra

SERRATURE SEMIAUTOMATICHE SEMI-AUTOMATIC DOOR LOCKS



927K



940K



950G

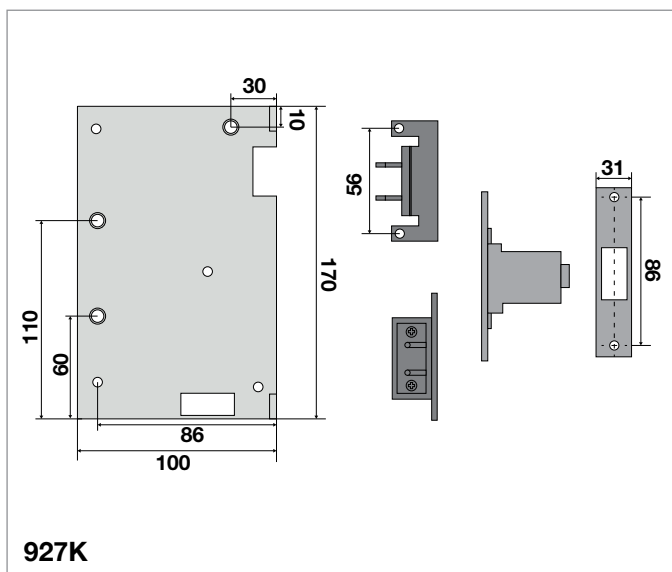

927K

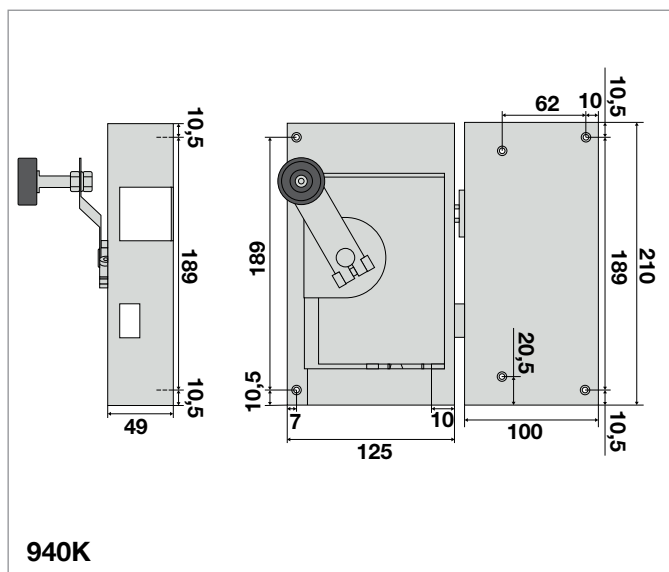

940K

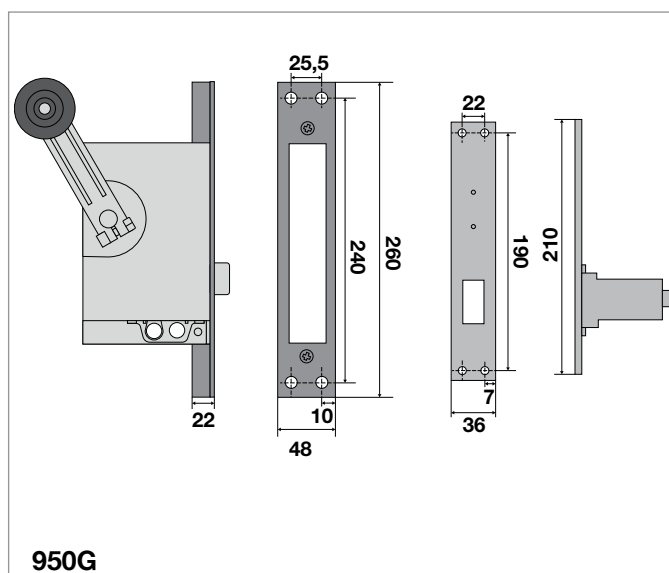

950G

N.B. Disegnati kit anche con sole piastre singole. Ogni kit comprende serratura con leva e contatto.

Codice / Code	Descrizione
927K	Kit sostituzione serratura SICEM semiautomatica omologata
940K	Kit sostituzione serratura SCHINDLER semiautomatica omologata
950G	Kit sostituzione serratura SCHINDLER semiautomatica per porte in legno

SERRATURE SEMIAUTOMATICHE ORIGINALI TF ORIGINAL TF SEMIAUTOMATIC DOOR LOCKS



930/4



931

Serratura TF semiautomatica con doppio blocco di sicurezza meccanico ed elettrico adatte all'applicazione su porte di piano a battente per ascensore.

Door locks TF semiautomatic with double mechanical and electrical security lock suitable for application on landing door for lift

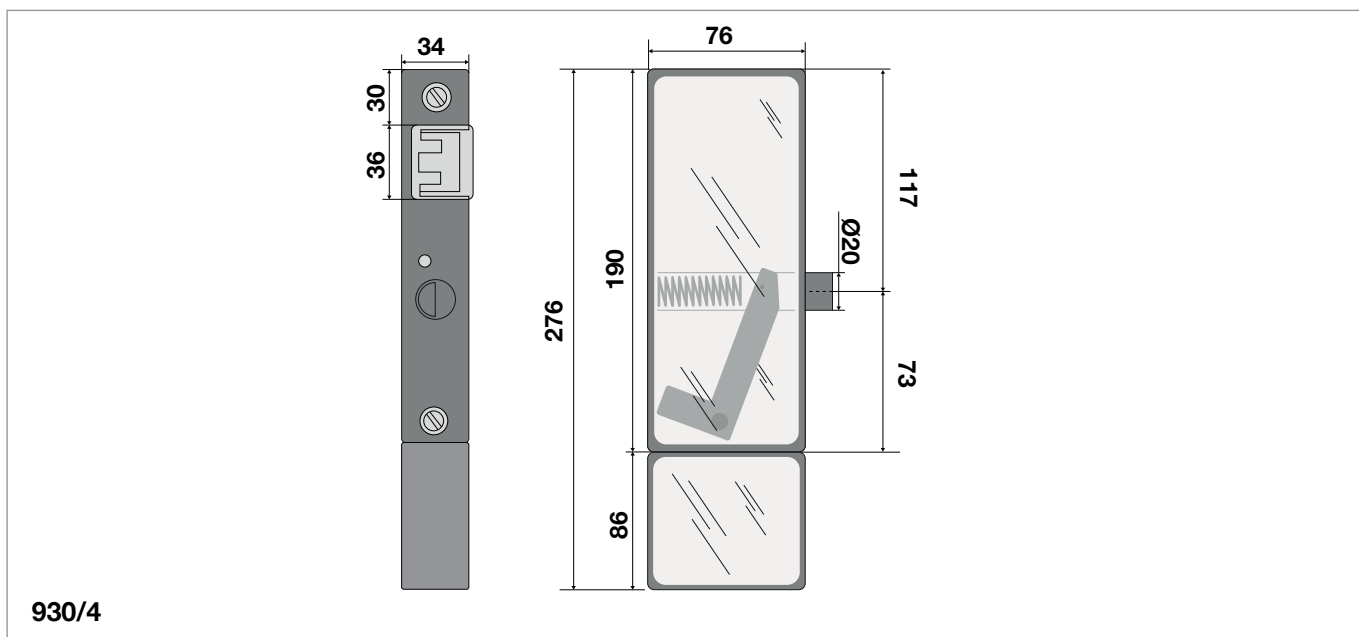

930/4

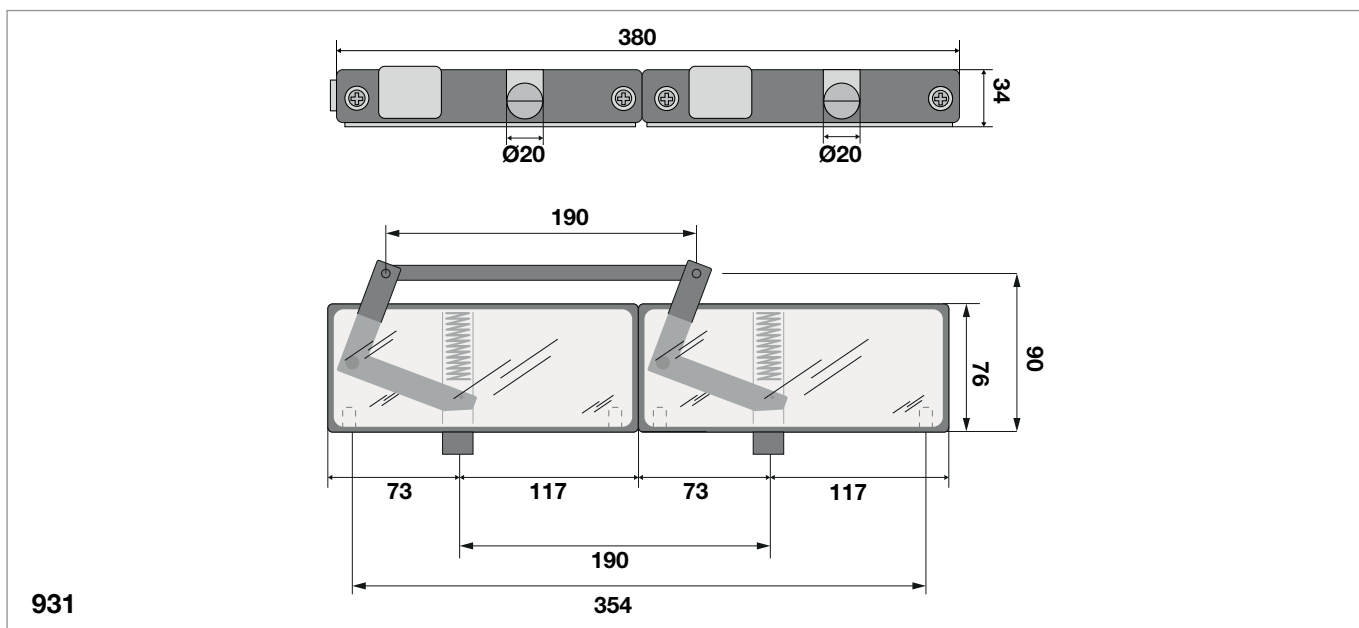

931

Codice / Code	Descrizione
930/4	Serratura semiautomatica EN81 TF con elettromagnete
931	Serratura semiautomatica EN81 TF a doppio catenaccio

SERRATURE SEMIAUTOMATICHE ORIGINALI TF ORIGINAL TF SEMIAUTOMATIC DOOR LOCKS



Serrature TF semiautomatiche con doppio blocco di sicurezza meccanico ed elettrico adatte all'applicazione su porte di piano a battente per ascensore.

Door locks TF semiautomatic with double mechanical and electrical security lock suitable for application on landing door for lift

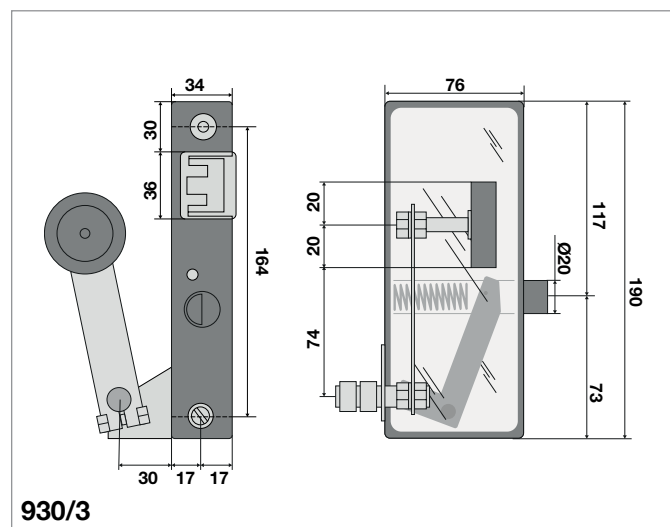
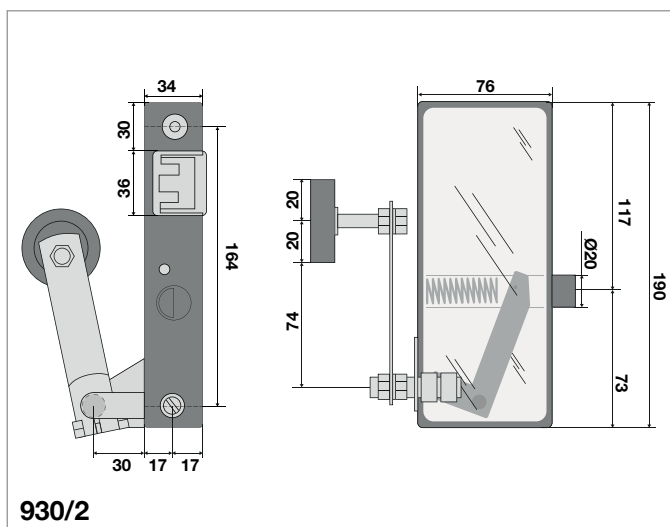
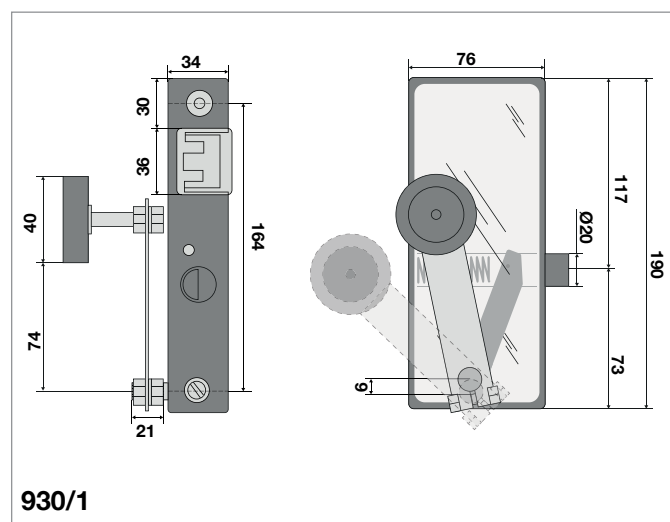
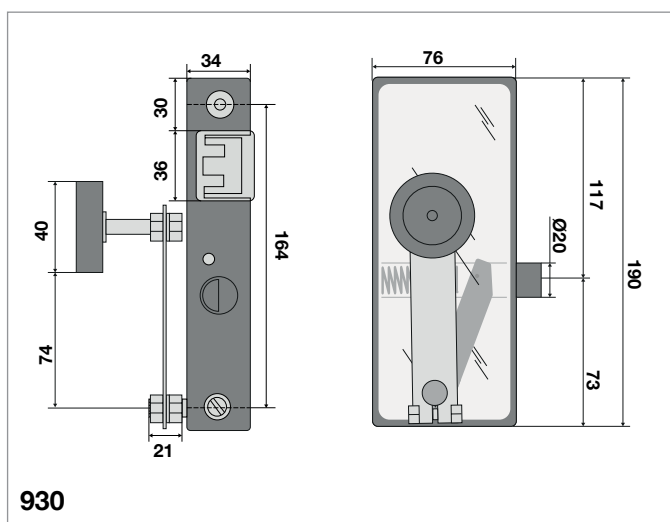

Codice / Code	Descrizione
930	Serratura semiautomatica EN81 TF per porte ad un battente
930/1	Serratura semiautomatica EN81 TF con perno disassato a movimento flottante
930/2	Serratura semiautomatica EN81 TF con leva a 90° esterna
930/3	Serratura semiautomatica EN81 TF con leva a 90° interna

SERRATURA CL INTERCAMBIABILE SERRATURA TF TF DOOR LOCK INTERCHANGEABLE CL DOOR LOCKS

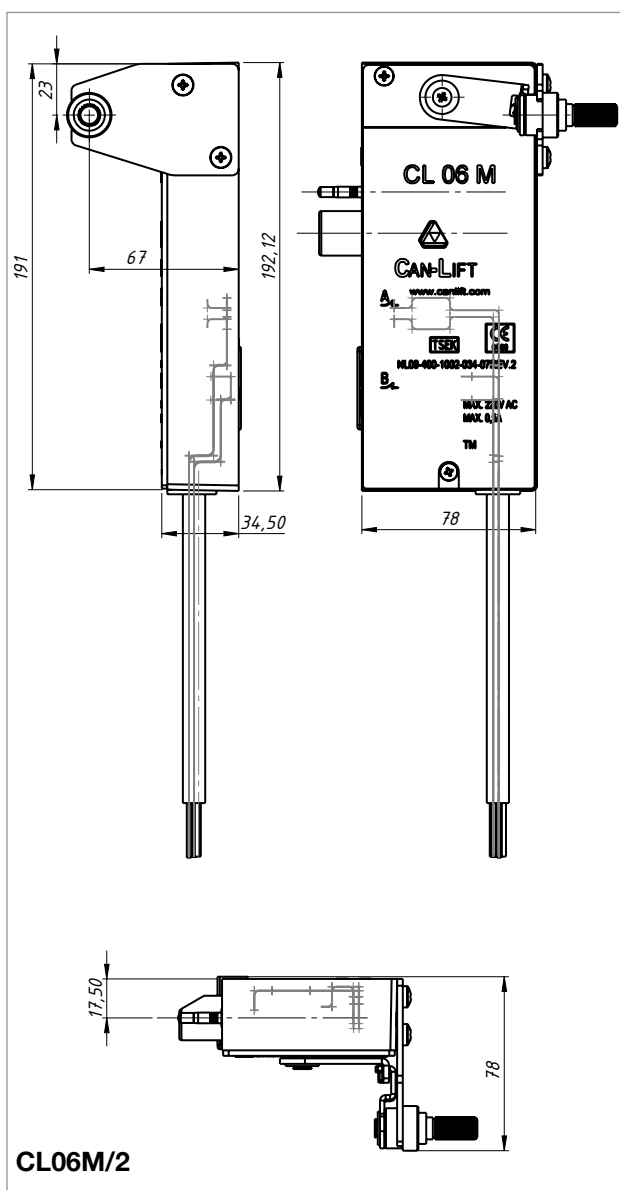
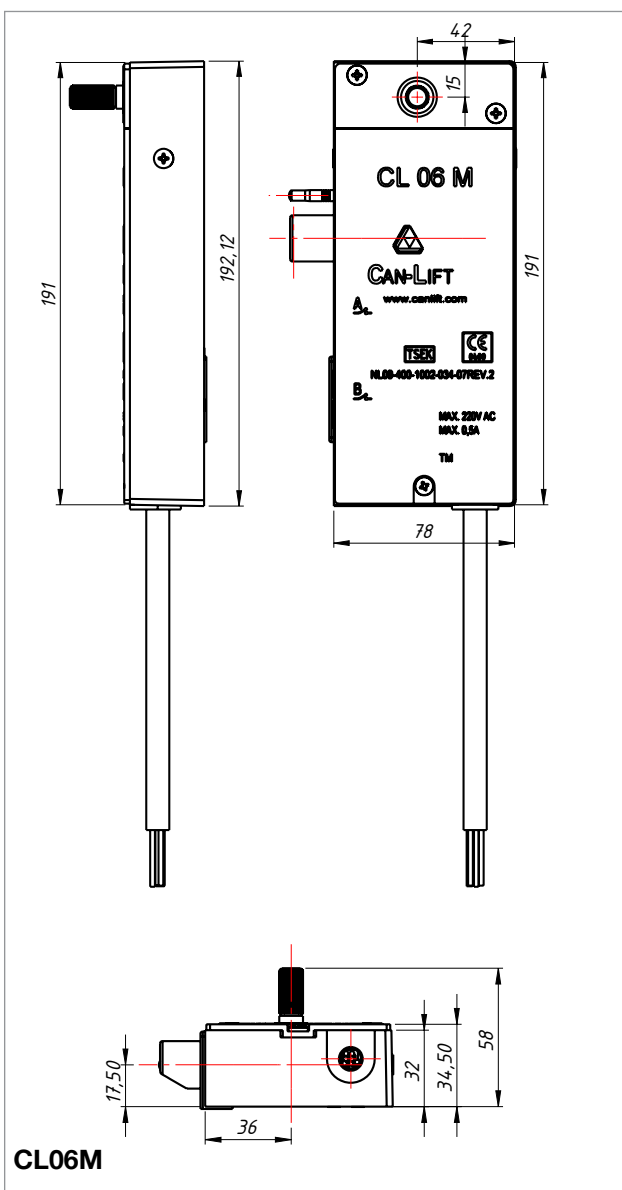
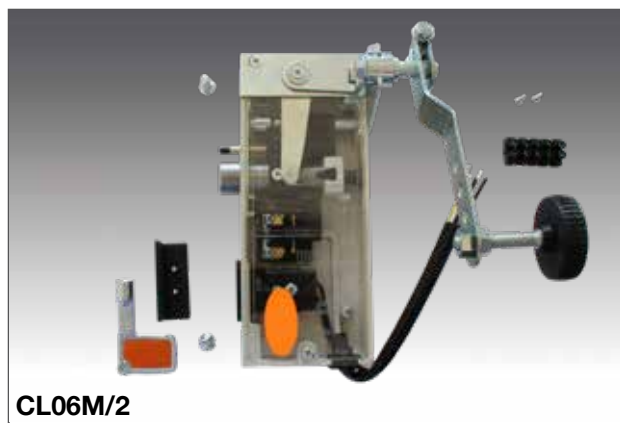

Codice / Code	Descrizione
CL06M	Serratura certificata per sostituzione serratura TF
CL06M/1	Serratura certificata per sostituzione serratura TF con perno flottante (non raffigurata)
CL06M/2	Serratura CL intercambiabile TF con leva 90° esterna

SERRATURA CL INTERCAMBIABILE SERRATURA TF
TF DOOR LOCK INTERCHANGEABLE CL DOOR LOCKS

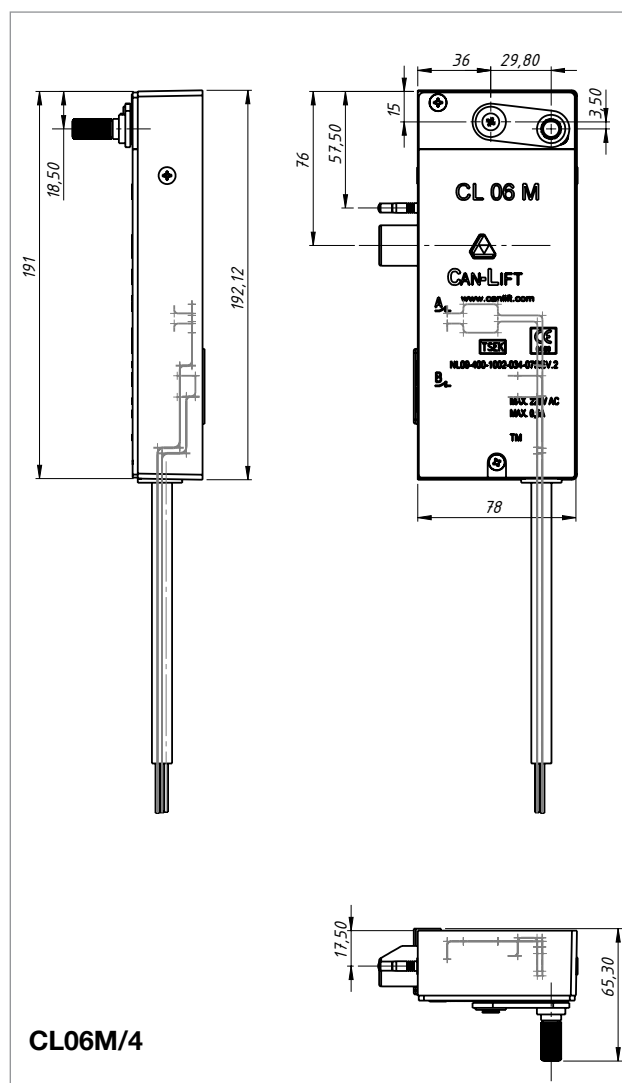
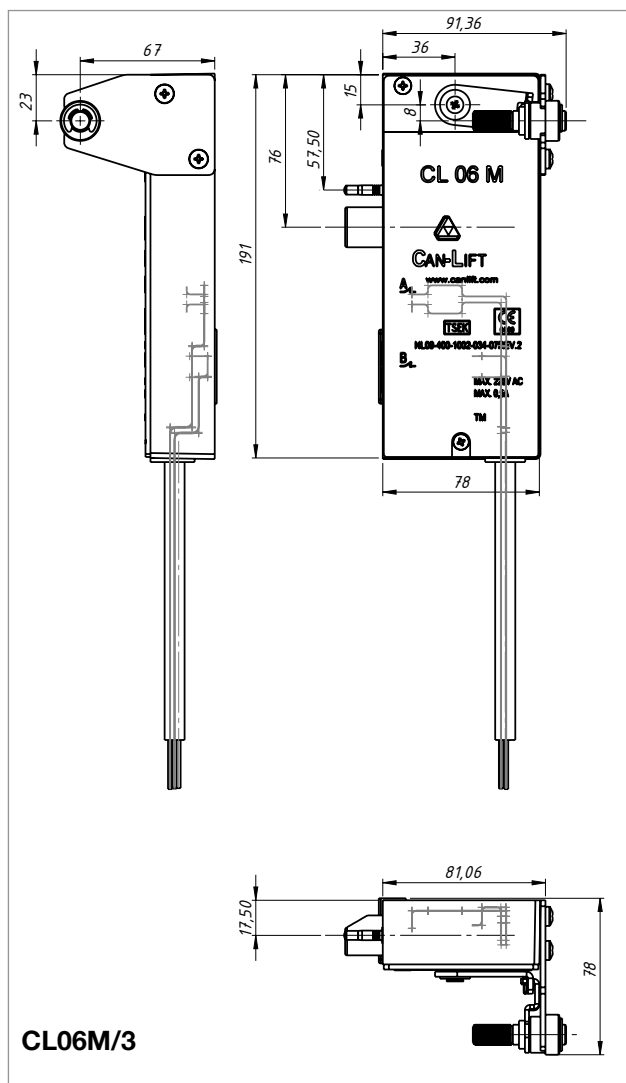
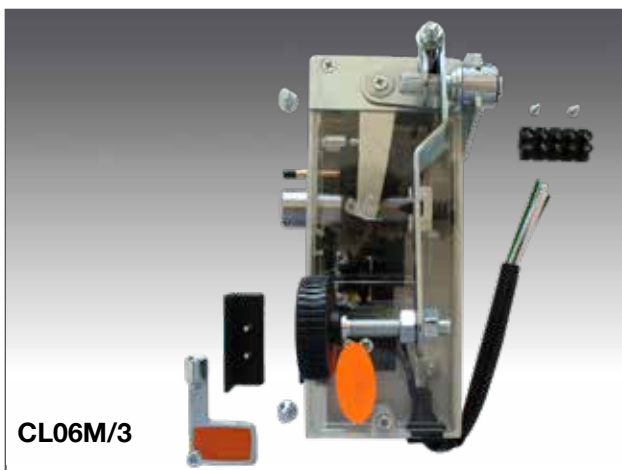

14

Codice / Code	Descrizione
CL06M/3	Serratura CL intercambiabile TF con leva 90° interna
CL06M/4	Serratura certificata per sostituzione serratura TF con perno disassato

SERRATURA CL INTERCambiabile SERRATURA TF TF DOOR LOCK INTERCHANGEABLE CL DOOR LOCKS

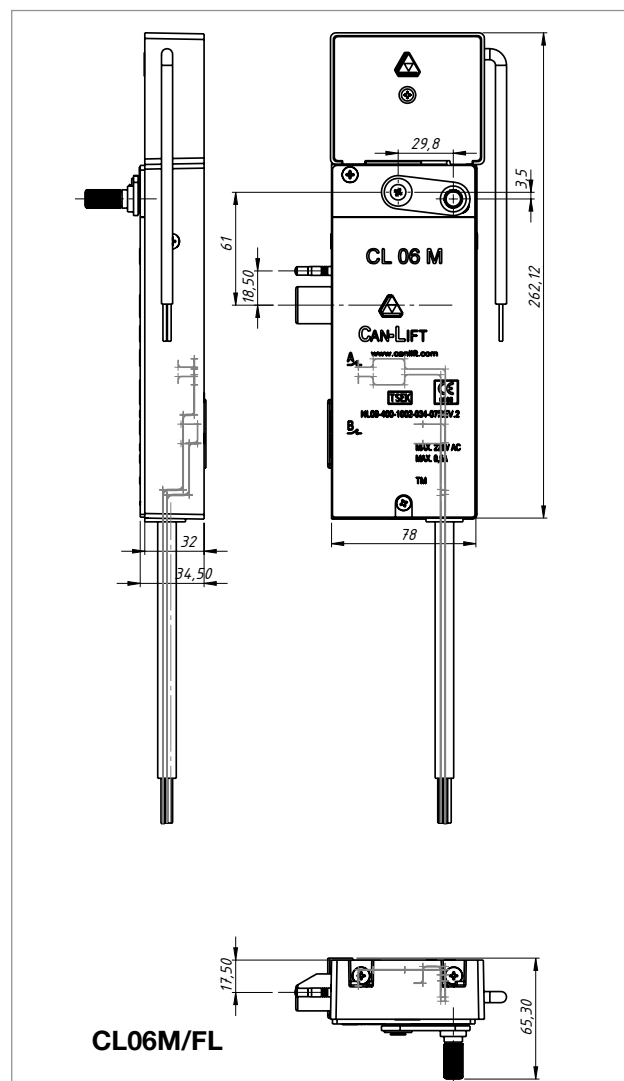
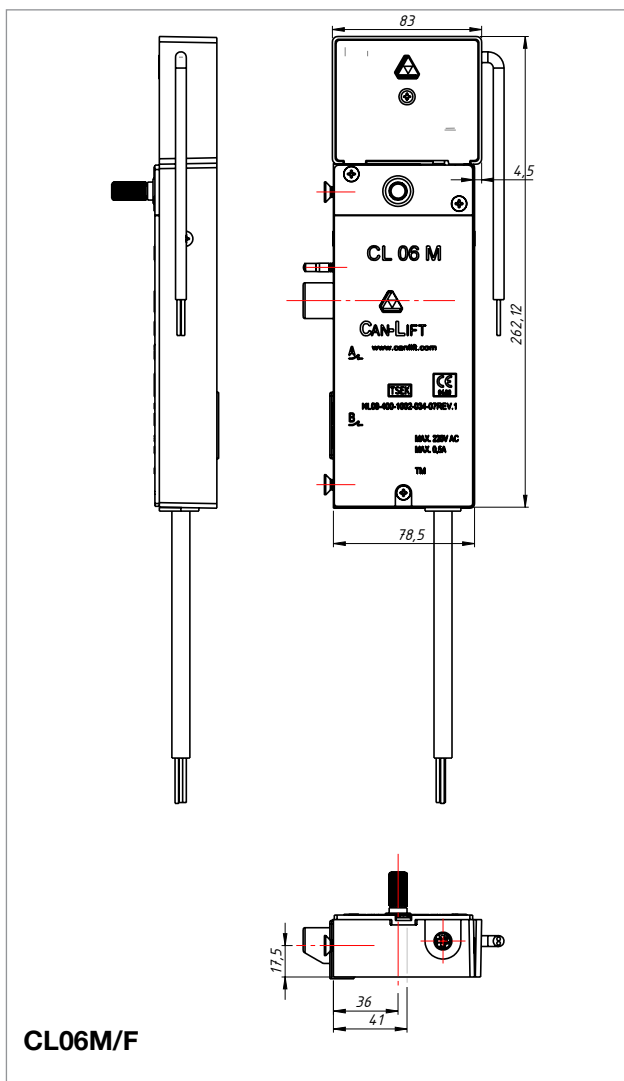
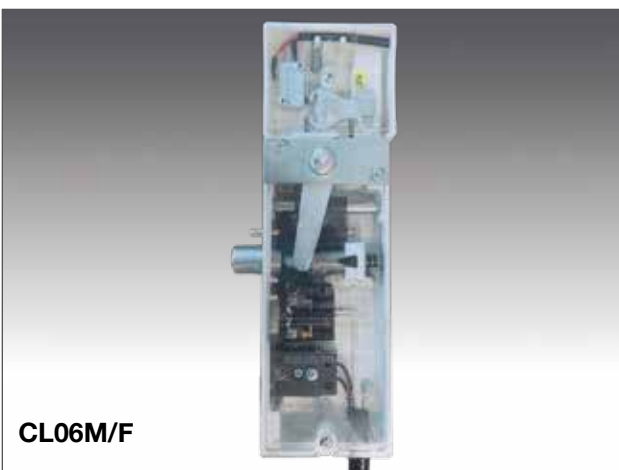

Codice / Code	Descrizione
CL06M/F	Serratura certificata per sostituzione serratura TF completa con contatto in fossa
CL06M/FL	Serratura certificata con perno leva decentrato e movimento standard con contatto in fossa

SERRATURA CL INTERCAMBIABILE SERRATURA TF TF DOOR LOCK INTERCHANGEABLE CL DOOR LOCKS

CL07M/FL



CL08M/FL

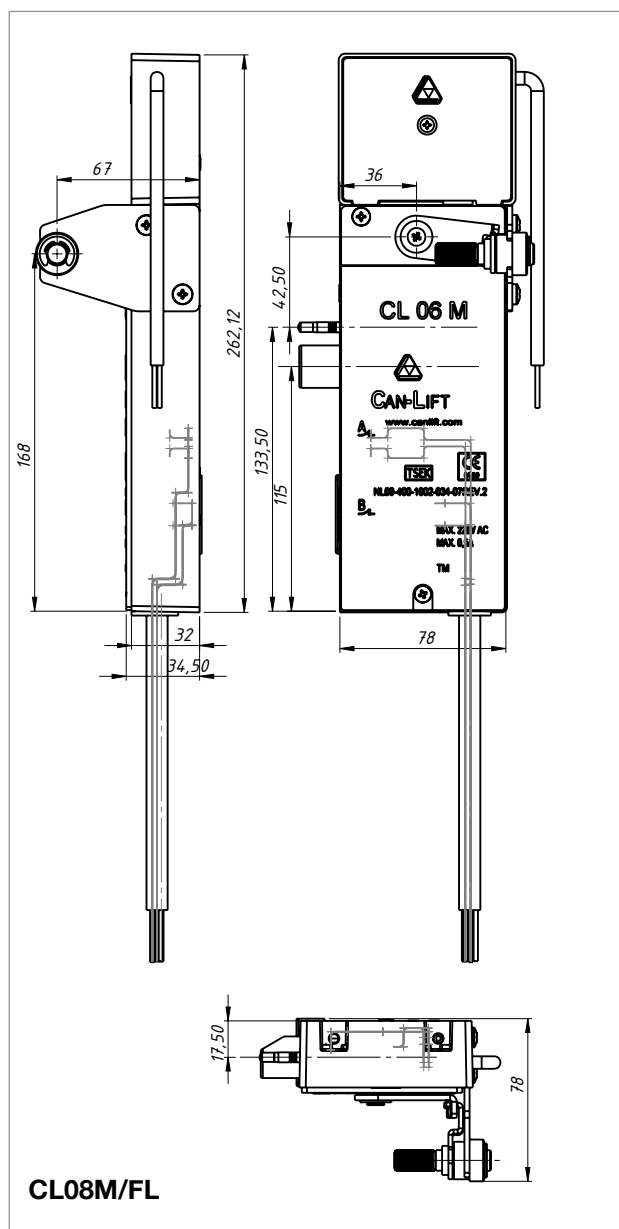
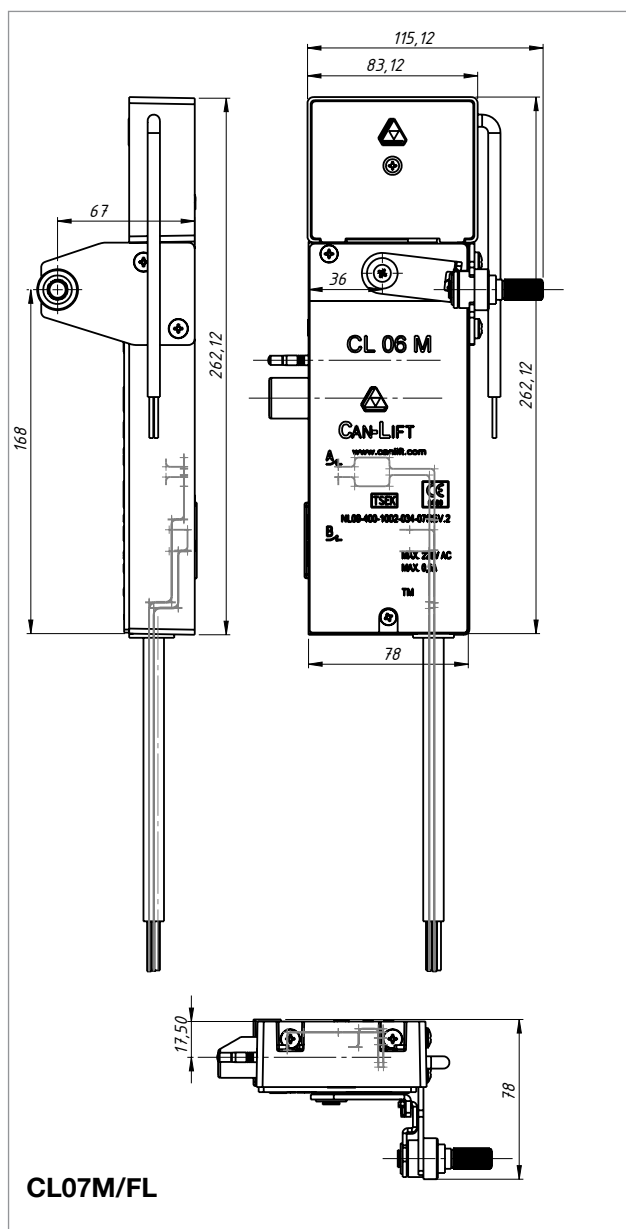

Codice / Code

Descrizione

CL07M/FL

Serratura CL con leva 90° esterna + contatto in fossa

CL08M/FL

Serratura CL con leva 90° interna + contatto in fossa

**SERRATURA CL INTERCAMBIABILE SERRATURA TF
TF DOOR LOCK INTERCHANGEABLE CL DOOR LOCKS**

CL09M/FLD

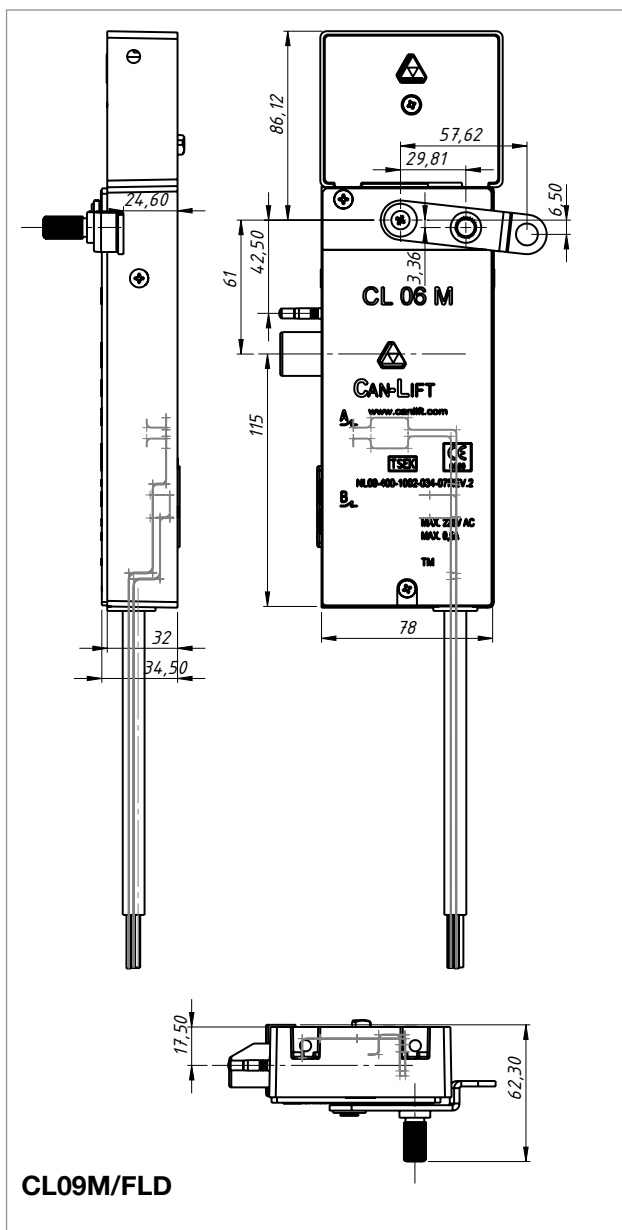
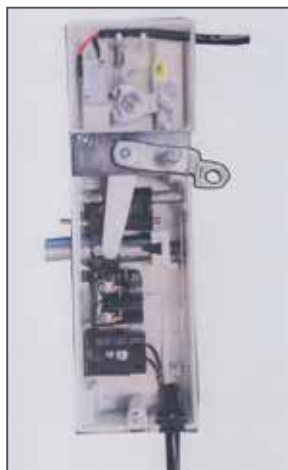

CL09M/FLD



CL06M-MT/SW

Codice / Code	Descrizione
CL09M/FLD	Serratura CL con leva decentrata e attacco fune + attacco fossa
CL06M-MT/SW	Serratura elettrica CL 24VCC certificata

SERRATURE SEMIAUTOMATICHE SEMIAUTOMATIC DOOR LOCKS

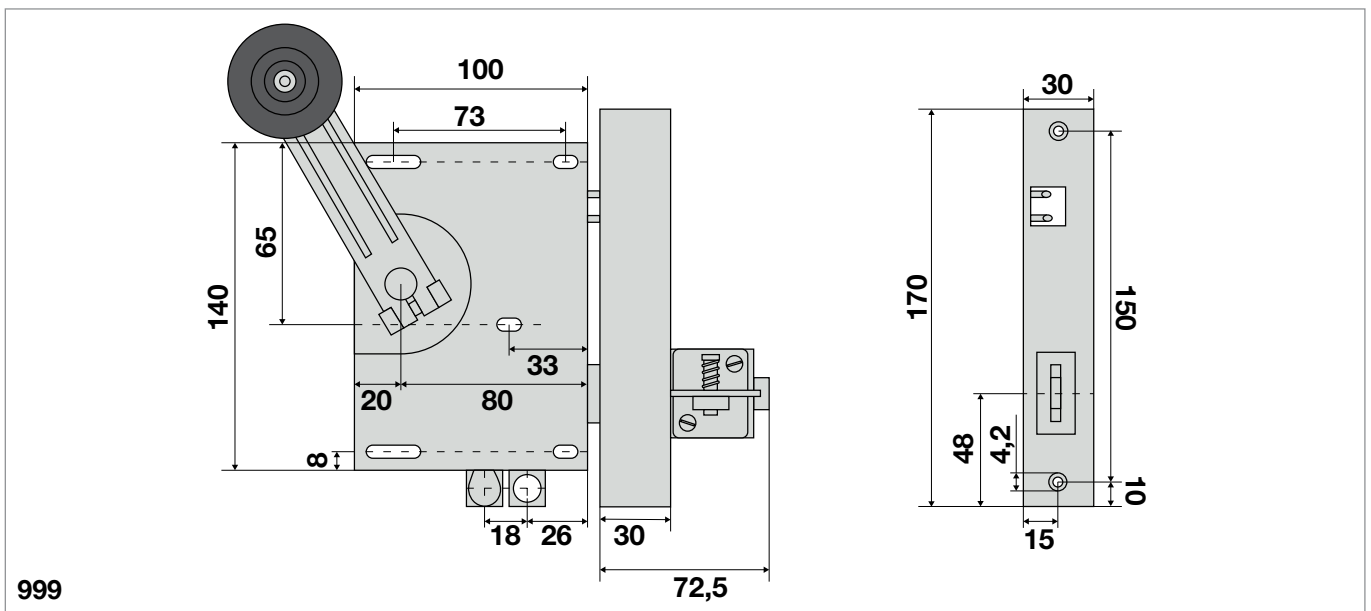
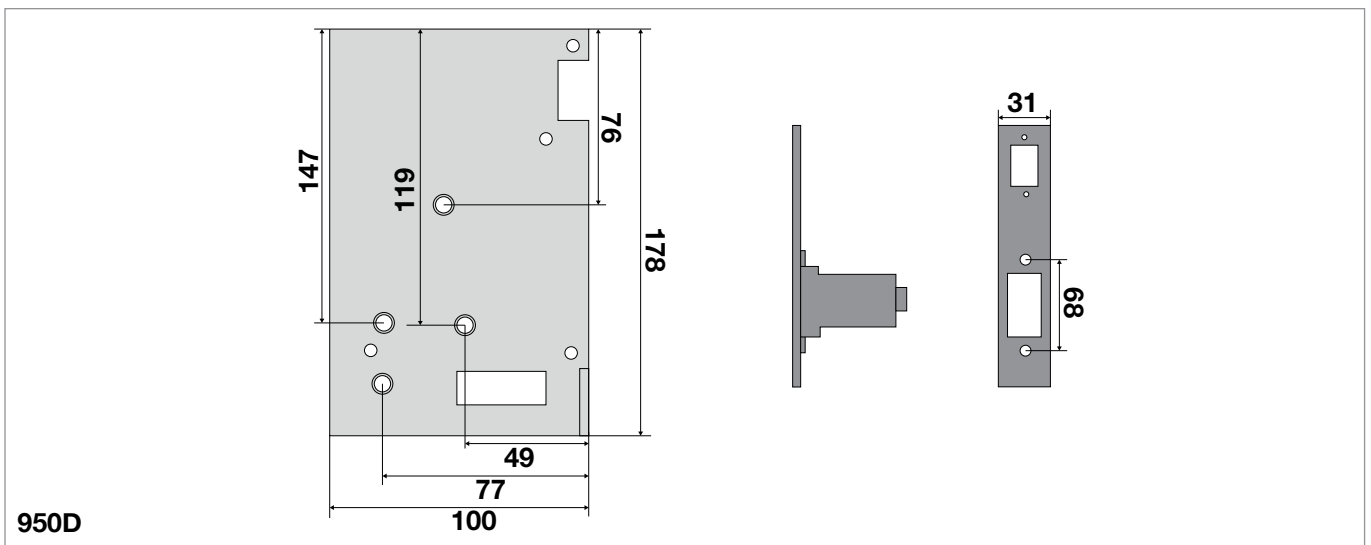

N.B. Disegnati kit anche con sole piastre singole. Ogni kit comprende serratura con leva e contatto.

Codice / Code	Descrizione
950D	Kit sostituzione serratura WENGHEL semiautomatica omologata
999	Kit sostituzione serratura UCE semiautomatica omologata
999/1	Solo parte mobile serratura COD.999 UCE

SERRATURE MANUALI BASSETTI BASSETTI MANUAL DOOR LOCKS

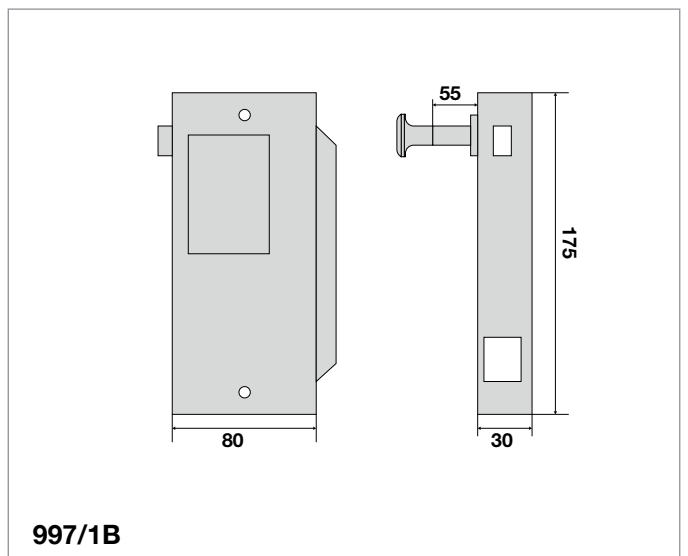
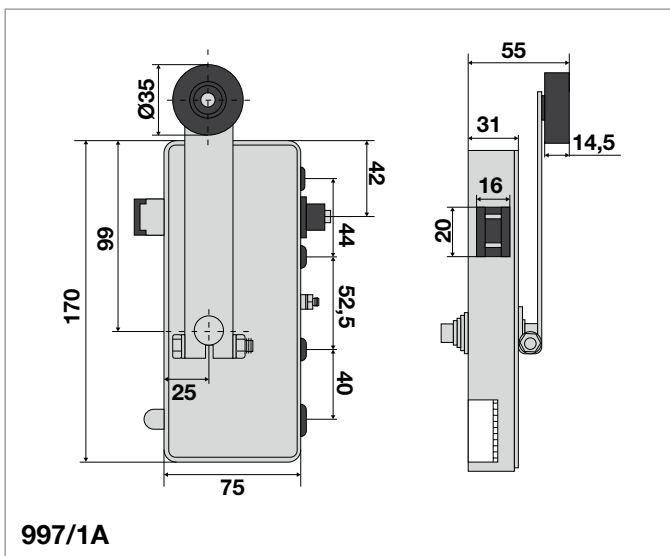
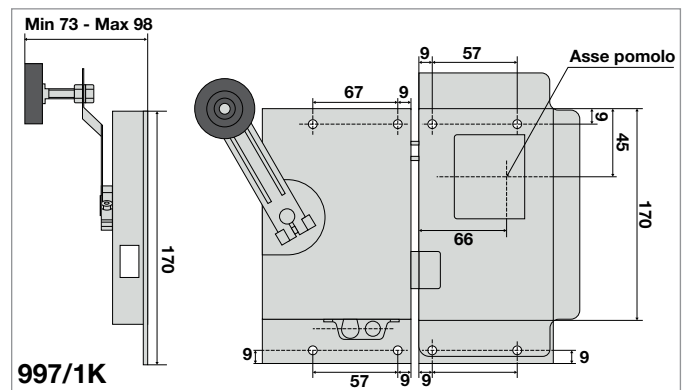
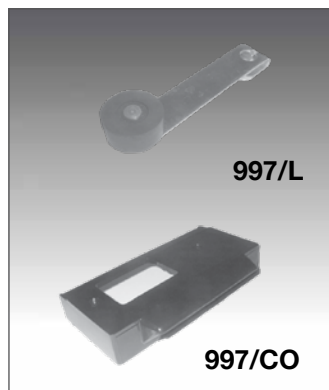

Codice / Code	Descrizione
997/1	Serratura a pomolo non omologata BASSETTI
997/1K	Kit sostituzione serratura BASSETTI a pomolo omologata
997/1A	Parte elettrica con emergenza serratura non omologata BASSETTI cod.997/1
997/1B	Parte mobile a pomolo cromato serratura a pomolo non omologata BASSETTI cod.997/1
997/1R	Rosetta per serratura BASSETTI a pomolo non omologata cod.997/1
997/1P	Pomolo cromato per serratura a pomolo non omologata BASSETTI cod.997/1
997/L	Leva con rotella per serratura semiautomatica omologata BASSETTI cod.997
997/CO	Coperchio serratura a pomolo BASSETTI

SERRATURE MANUALI MANUAL DOOR LOCKS

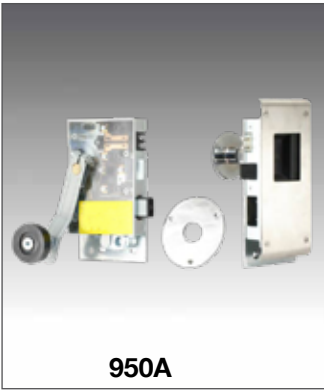

950A



950B



950C

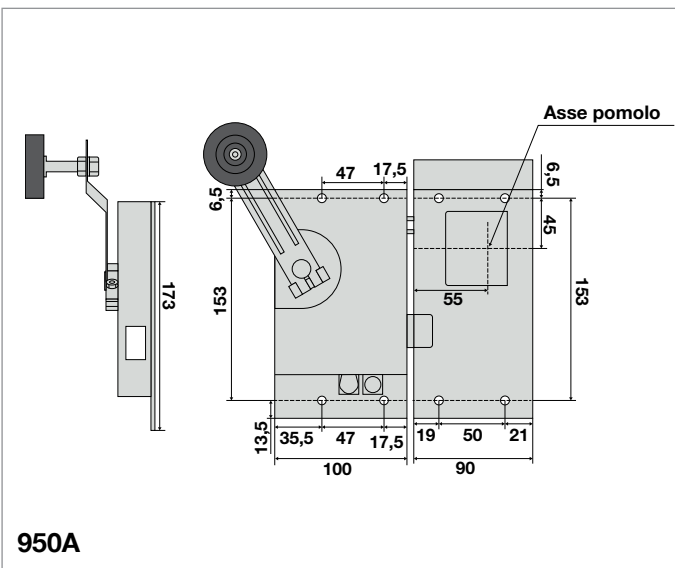

950A

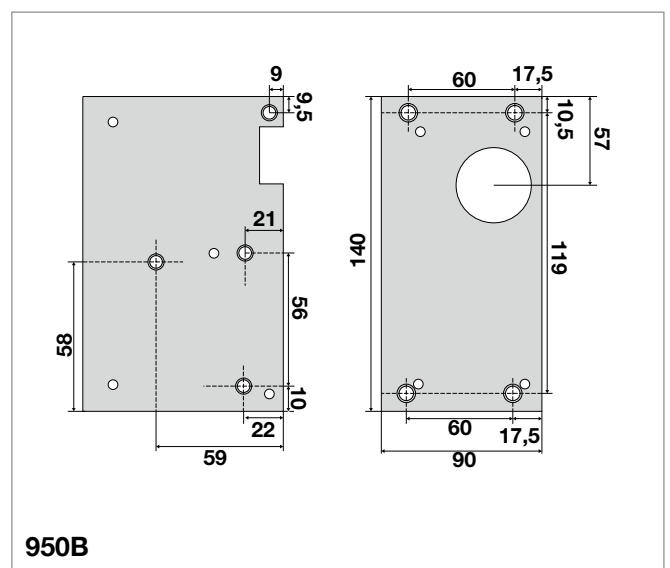

950B

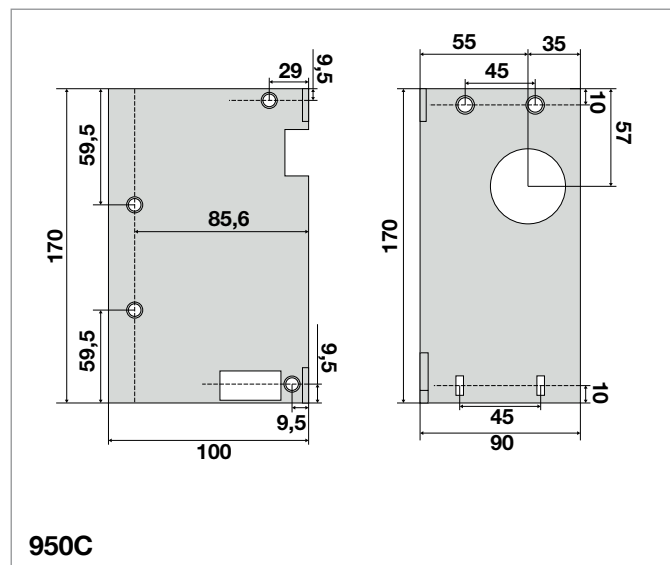

950C

N.B. Disegnati kit anche con sole piastre singole. Ogni kit comprende serratura con leva e contatto.

Codice / Code	Descrizione
950A	Kit sostituzione serratura BONFEDI manuale omologata
950B	Kit sostituzione serratura DALLAGIOVANNA manuale omologata
950C	Kit sostituzione serratura SICEM manuale omologata

PARTI MECCANICHE SERRATURE MANUALI OMOLOGATE DMG
MECHANICAL AND MANUAL APPROVED DOOR LOCKS DMG

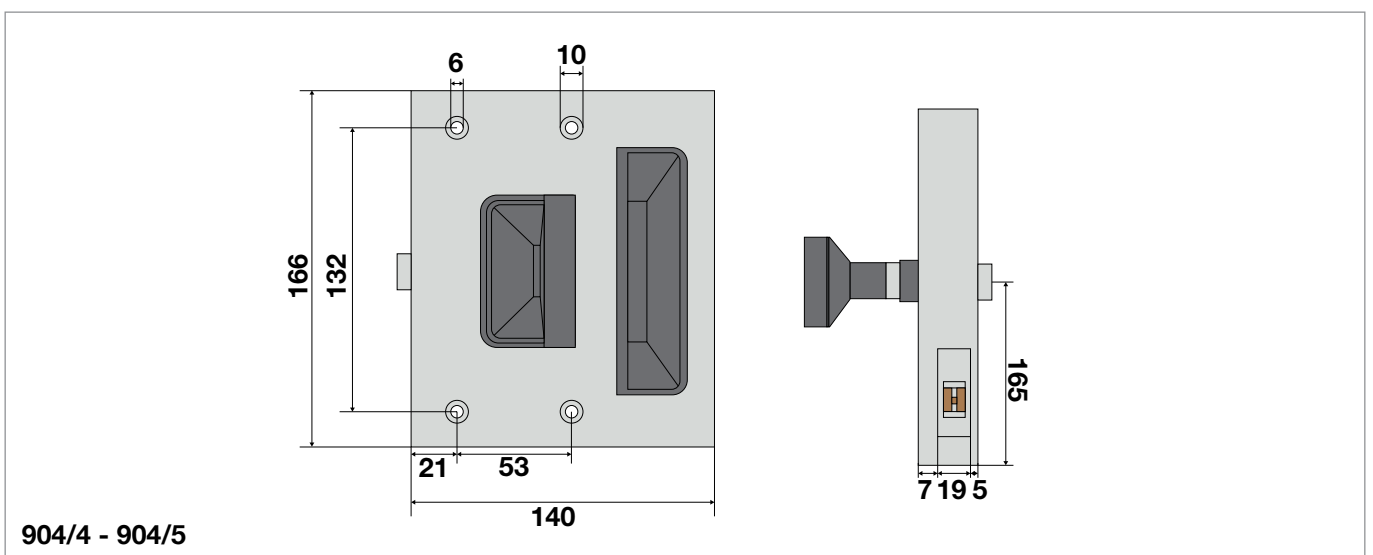
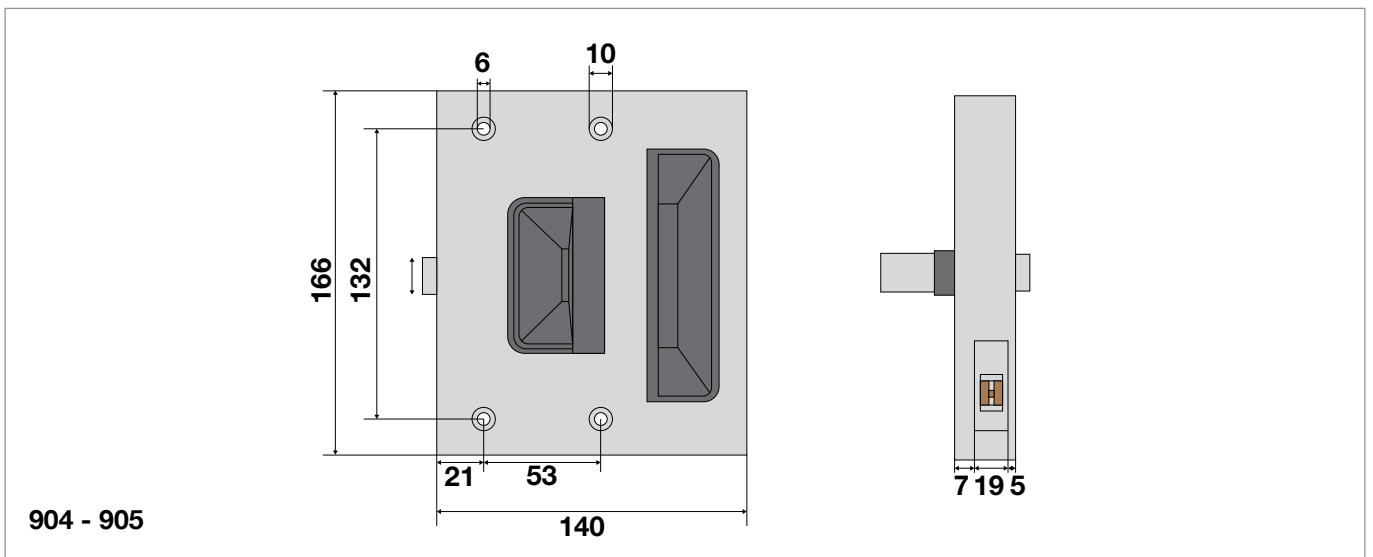
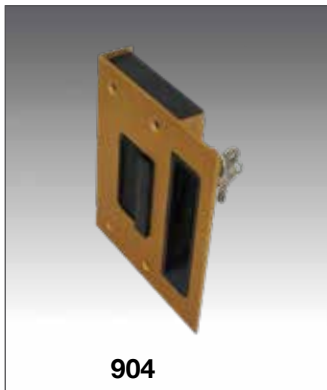

Codice / Code	Descrizione
904	Parte meccanica ad incasso ottonata con chiave serratura DMG
905	Parte meccanica ad incasso anodizzata con chiave serratura DMG
904/4	Parte meccanica ad incasso anodizzata con pomolo serratura DMG
904/5	Parte meccanica ad incasso ottonata con pomolo serratura DMG

PARTI MECCANICHE SERRATURE MANUALI OMOLOGATE DMG
MECHANICAL AND MANUAL APPROVED DOOR LOCKS DMG

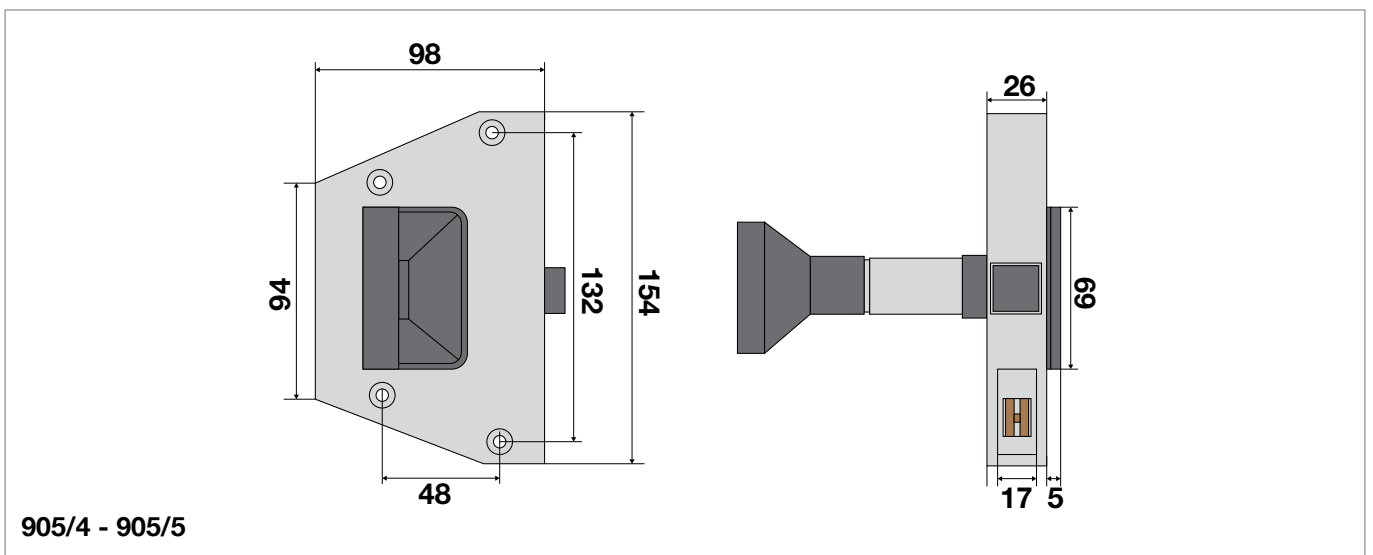
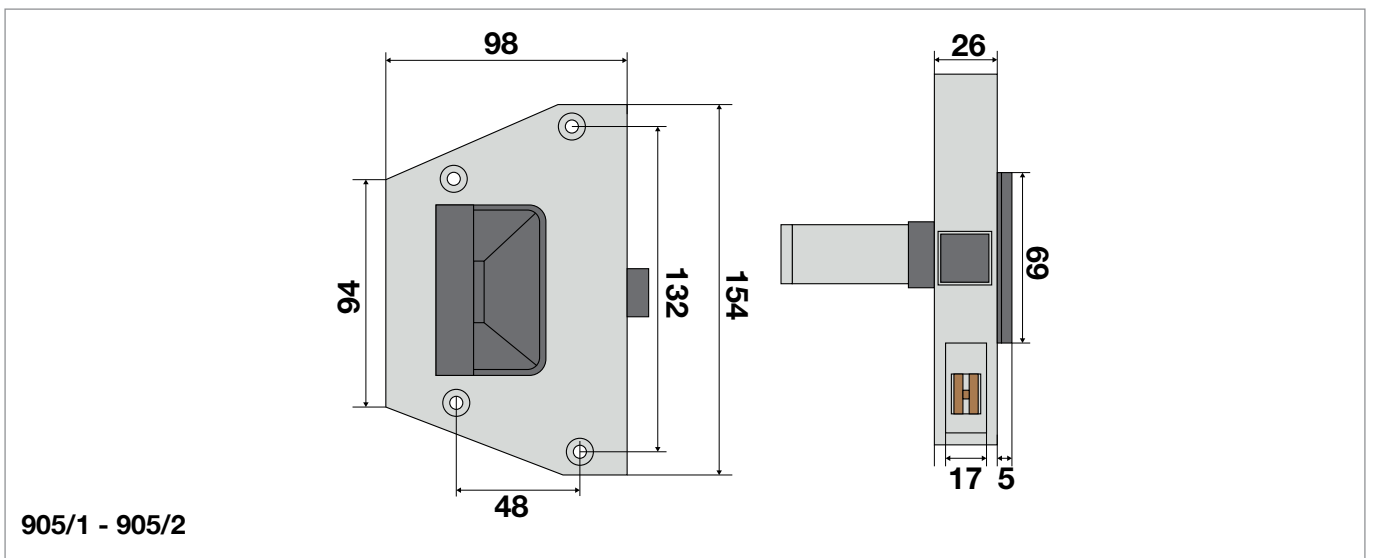

14

Codice / Code	Descrizione
905/1	Parte meccanica sovrapposta cromata con chiave serrature DMG
905/2	Parte meccanica sovrapposta ottonata con chiave serrature DMG
905/4	Parte meccanica sovrapposta cromata con pomolo serrature DMG
905/5	Parte meccanica sovrapposta ottonata con pomolo serrature DMG

PARTI MECCANICHE SERRATURE MANUALI OMOLOGATE DMG
MECHANICAL AND MANUAL APPROVED DOOR LOCKS DMG

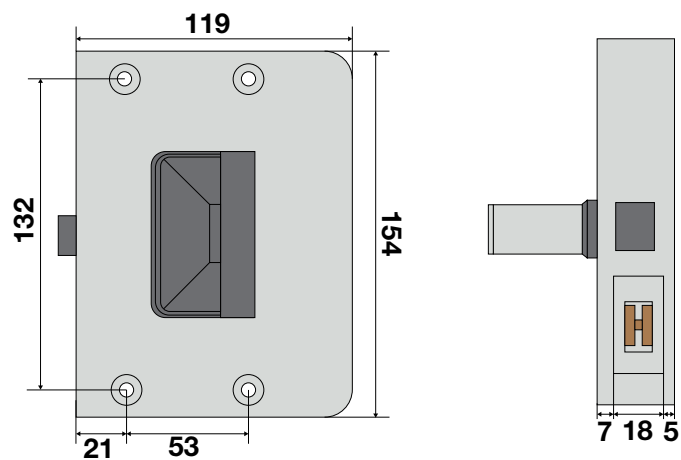

903 - 903/1

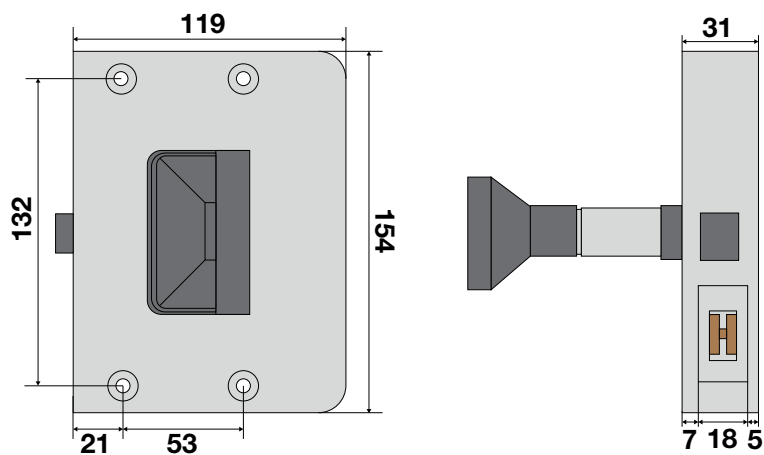

907 - 907/1

Codice / Code	Descrizione
903	Parte meccanica sovrapposta anodizzata con chiave serratura DMG
903/1	Parte meccanica sovrapposta ottonata con chiave serratura DMG
907	Parte meccanica sovrapposta anodizzata con pomolo serratura DMG
907/1	Parte meccanica sovrapposta ottonata con pomolo serratura DMG

SERRATURE MANUALI MANUAL DOOR LOCK



995

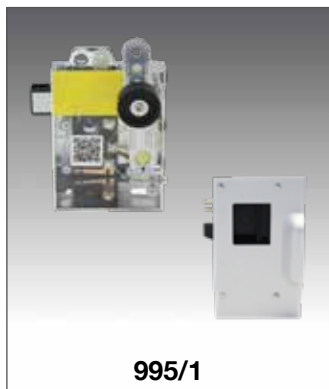

995/1



996

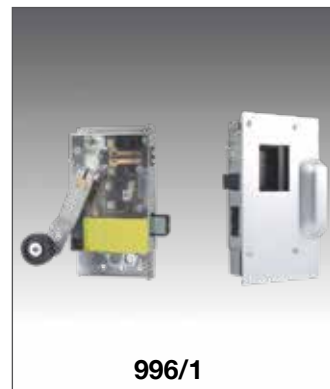

996/1

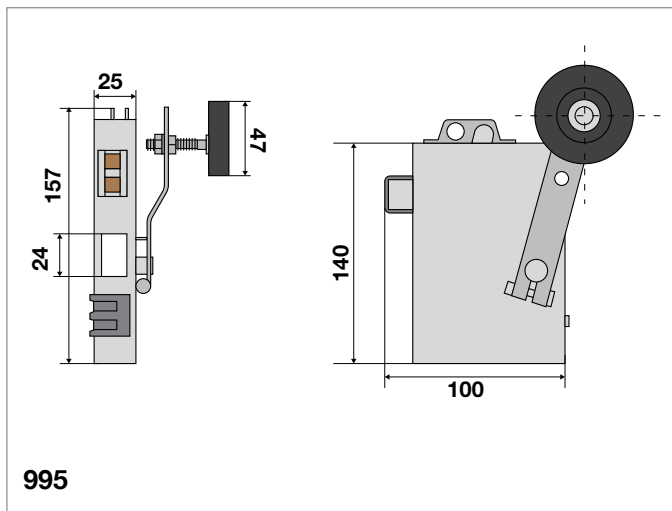

995

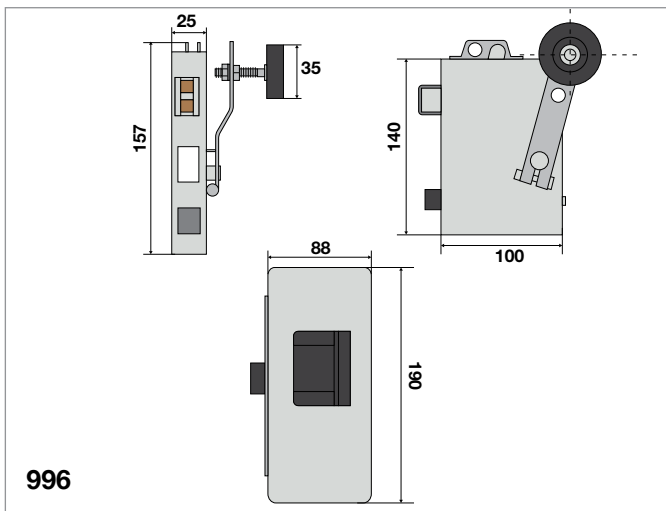

996

N.B. Disegnati kit anche con sole piastre singole. Ogni kit comprende serratura con leva e contatto.

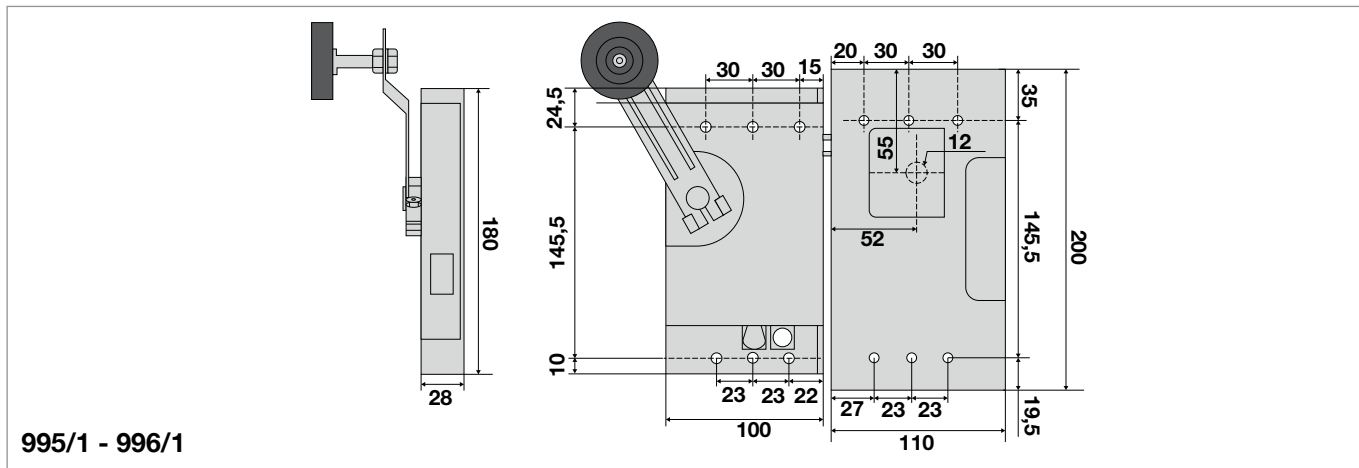

995/1 - 996/1

La serratura comprende kit di piastre con la possibilità di reinstallare il pomolo originale FALCONI, il pomolo delle serrature non è compreso come standard nel codice, e viene fornito su commessa.

The door lock kit includes the plate with the possibility of reinstalling the FALCONI original knob, the door lock knob is supplied by order, it's not included, as standard in the code.

Codice / Code	Descrizione
995	Kit serratura certificata per sostituzione serratura a pomolo FALCONI ad incasso non omologata
995/1	Kit serratura certificata per sostituzione serratura a pomolo FALCONI ad incasso omologata
996	Kit serratura certificata per sostituzione serratura a pomolo FALCONI sovrapposta non omologata
996/1	Kit serratura certificata per sostituzione serratura a pomolo FALCONI sovrapposta omologata

SERRATURE MANUALI MANUAL DOOR LOCKS

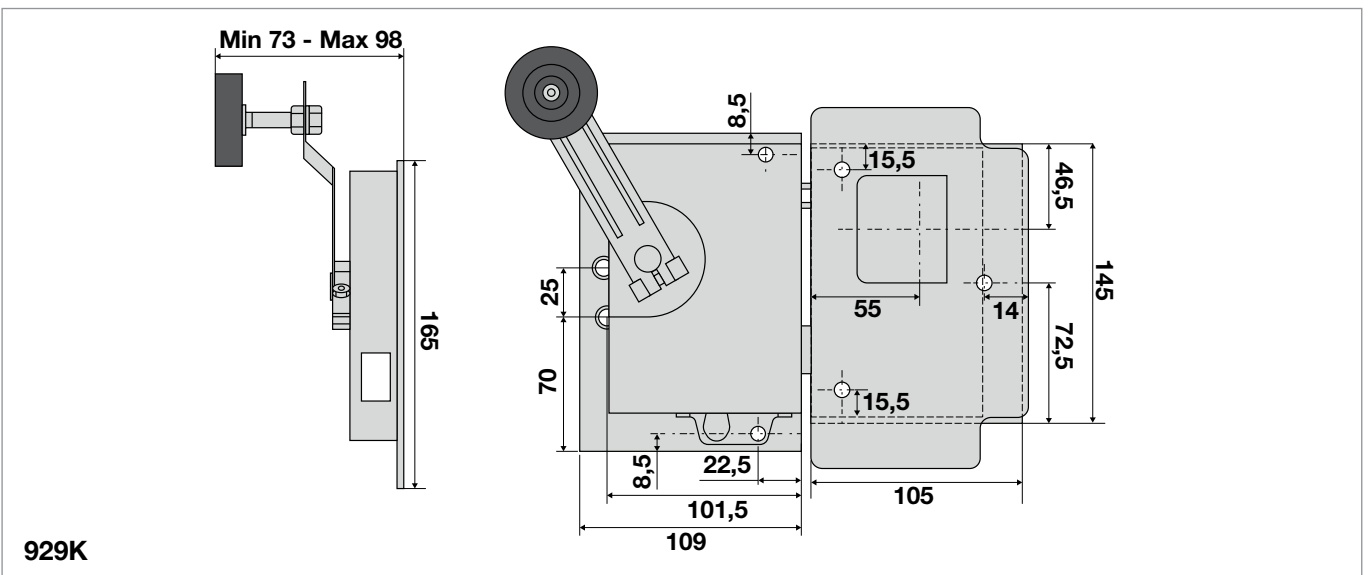
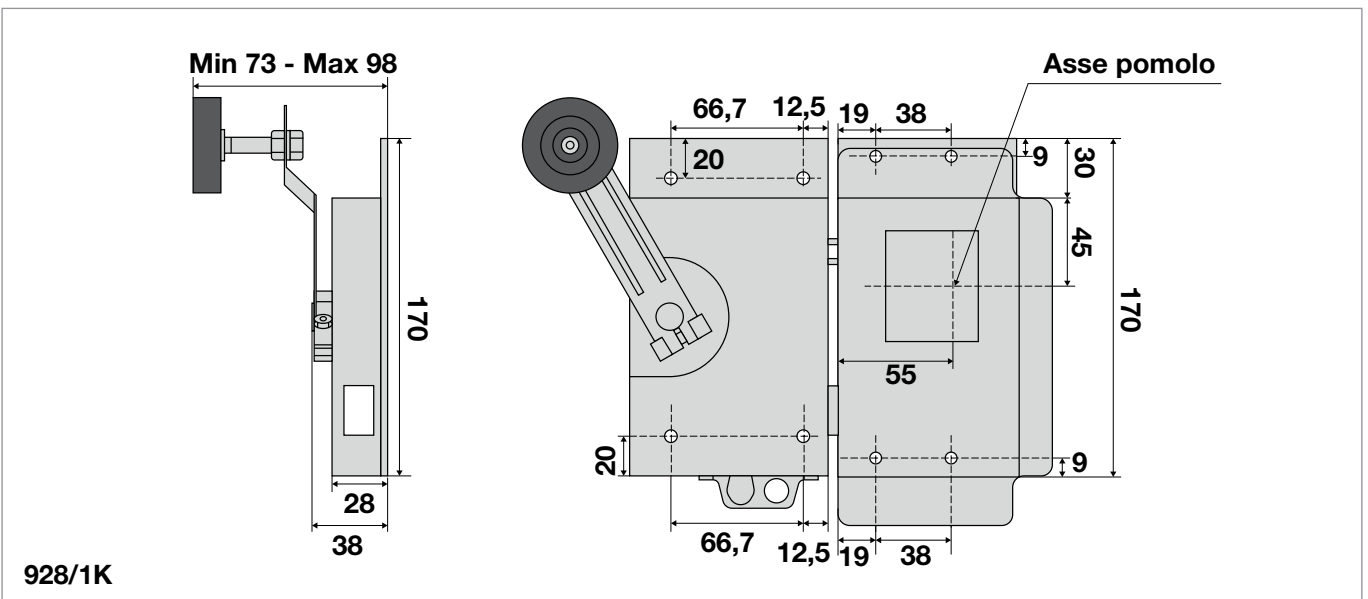

N.B. Disegnati kit anche con sole piastre singole. Ogni kit comprende serratura con leva e contatto.

Codice / Code	Descrizione
928/1K	Kit sostituzione serratura INSUBRIA-ATLAS manuale omologata
929K	Kit sostituzione serratura SABIEM E211 manuale omologata

SERRATURE A POMOLO FIAM FIAM DOOR LOCK WITH KNOB

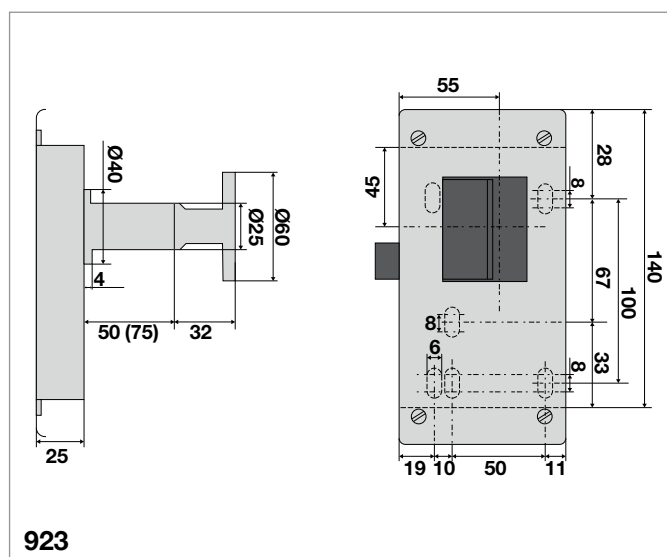
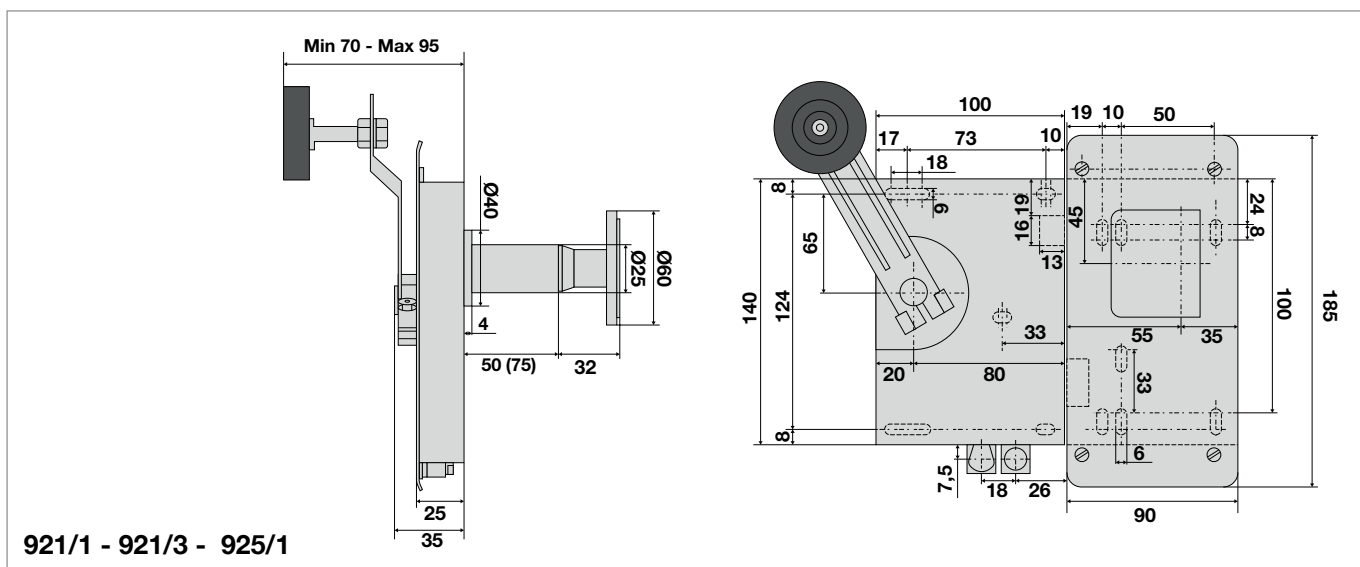
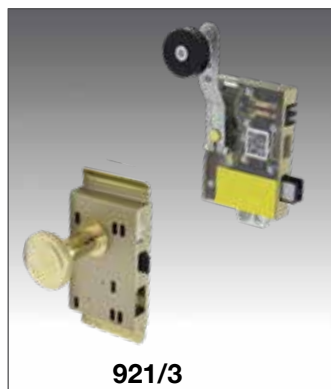

Codice / Code	Descrizione
921/1	Serratura a pomolo FIAM omologata EN81 IMQ
921/3	Serratura a pomolo ottone FIAM omologata EN81 IMQ
925/1	Serratura a pomolo con emergenza FIAM non omologata
923	Parte pomolo serratura FIAM non omologata

SERRATURE MANUALI MANUAL DOOR LOCKS



994/1K

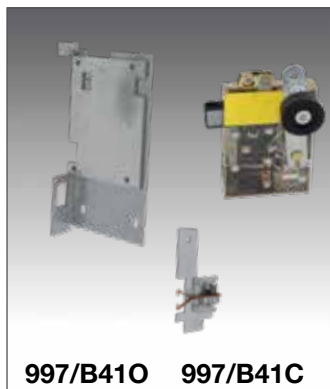

997/B41O 997/B41C

N.B. Disegnati kit anche con sole piastre singole. Ogni kit comprende serratura con leva e contatto.

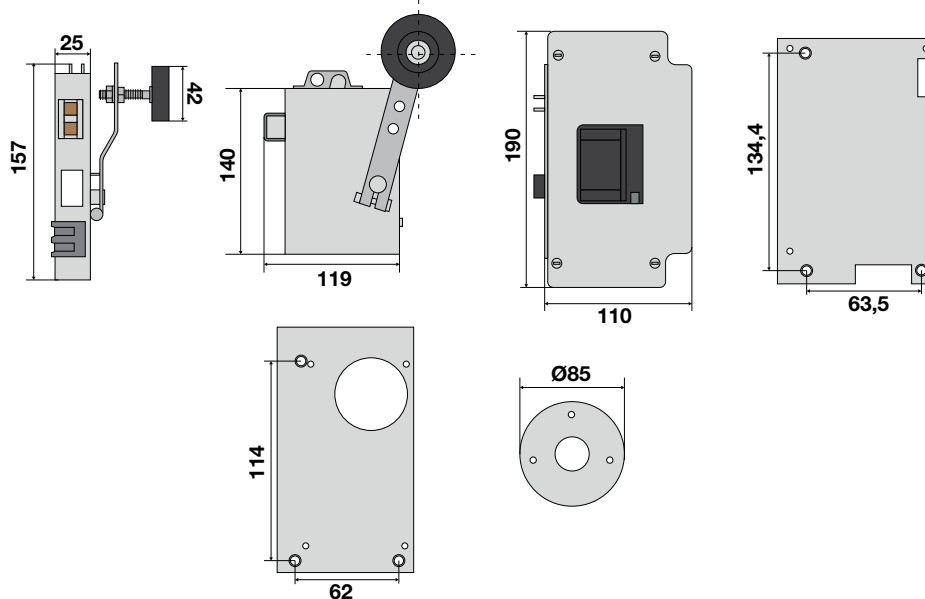

994/1K

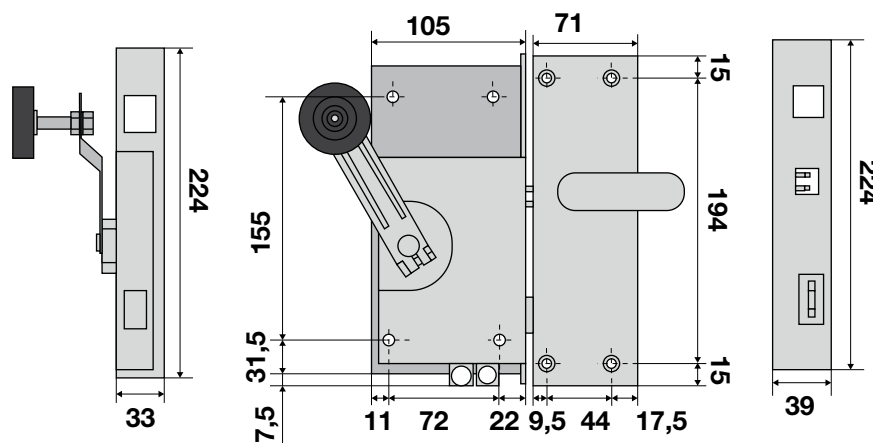

997/B41C 997/B41O

Codice / Code	Descrizione
994/1K	Kit sostituzione serratura a pomolo cromato FORSID-MONITOR omologata
997/B41C	Kit sostituzione serratura OTIS B41- B55 a pomolo cromata (pomolo da acquistare separatamente)
997/B41O	Kit sostituzione serratura OTIS B41 - B55 a pomolo ottonata (pomolo da acquistare separatamente)
997/41CP	Pomolo cromato per serratura cod.997/B41C

SERRATURE MANUALI MANUAL DOOR LOCKS

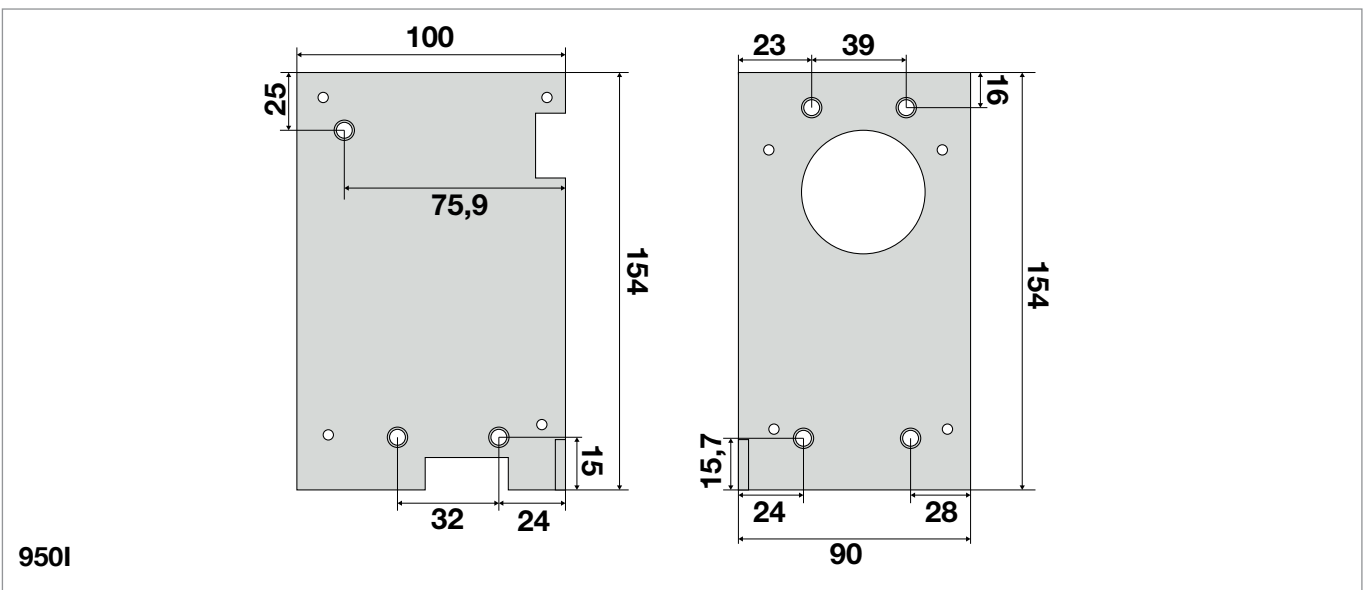
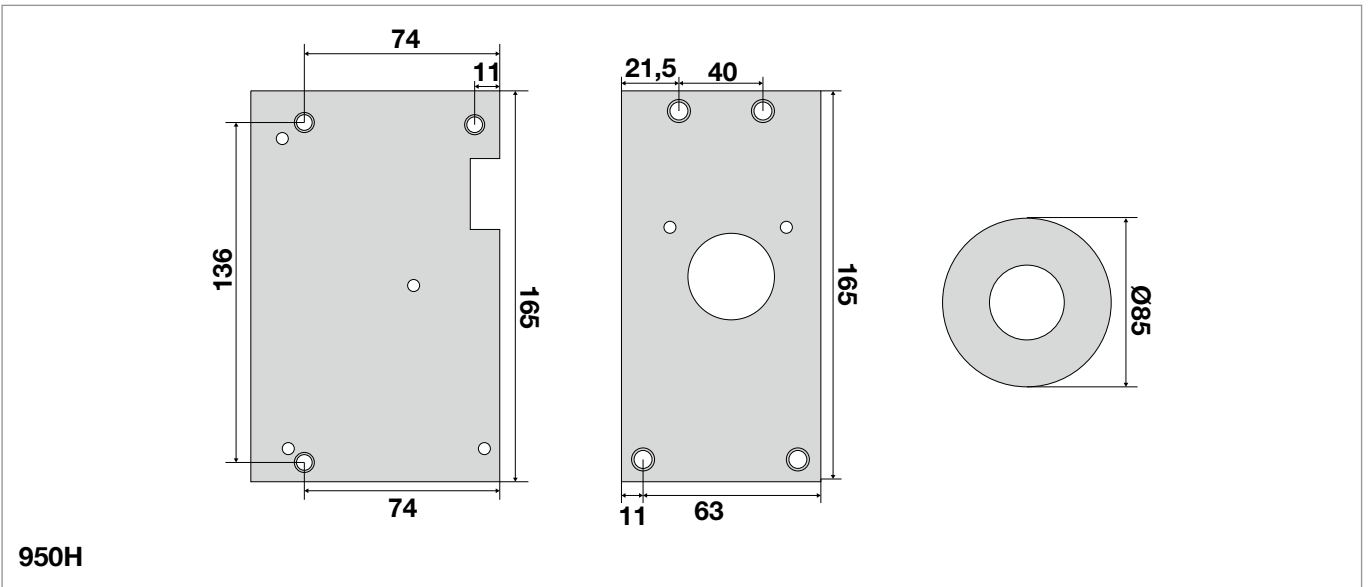
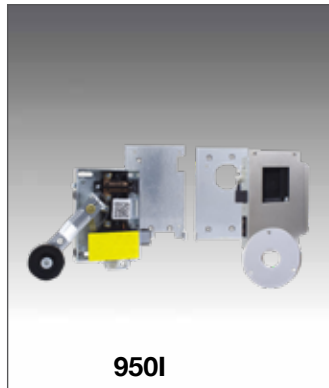

N.B. Disegnati kit anche con sole piastre singole. Ogni kit comprende serratura con leva e contatto.

Codice / Code	Descrizione
950H	Kit sostituzione serratura BOSISIO manuale
950I	Kit sostituzione serratura SCHLIEREN manuale omologata

RICAMBI PER SERRATURA DMG SPARE PARTS FOR DMG DOOR LOCKS

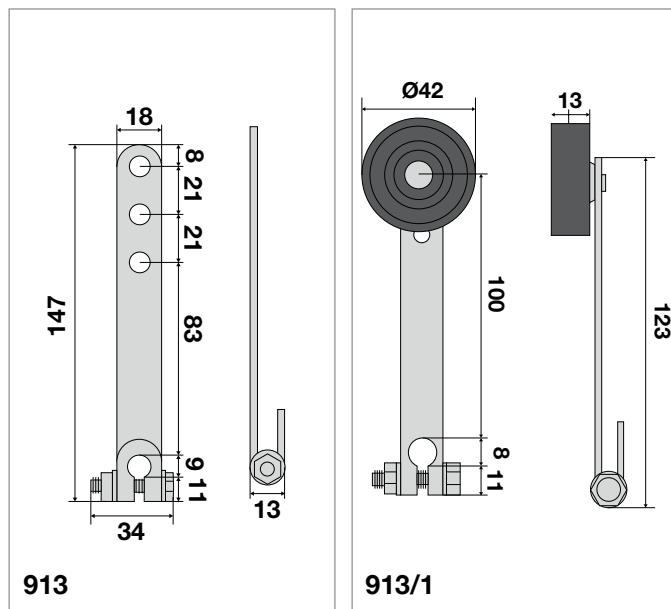
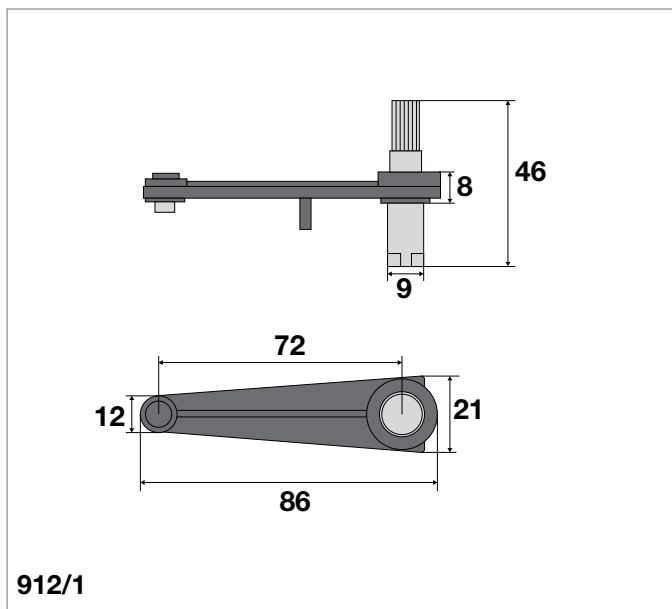
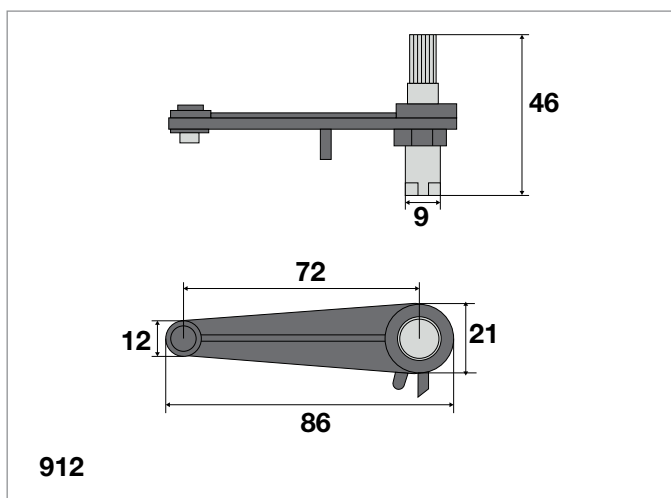
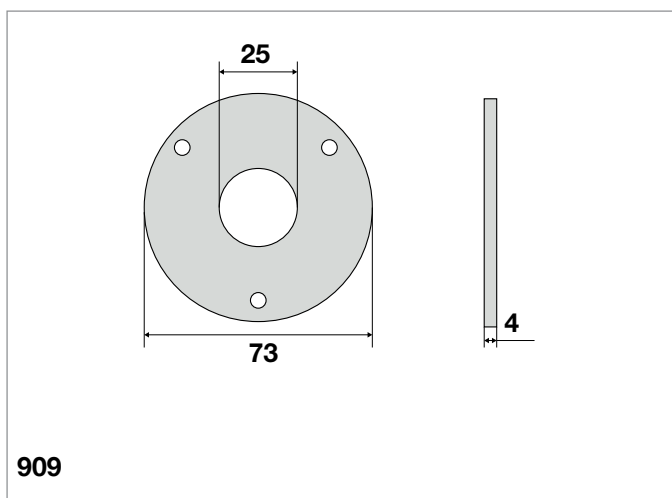

Codice / Code	Descrizione
909	Rosetta grande
912	Leva interna serratura non omologata
912/1	Leva interna serratura omologata
913	Leva a 3 fori
913/1	Leva con ruota Ø 42 mm

RICAMBI PER SERRATURA DMG SPARE PARTS FOR DMG DOOR LOCKS

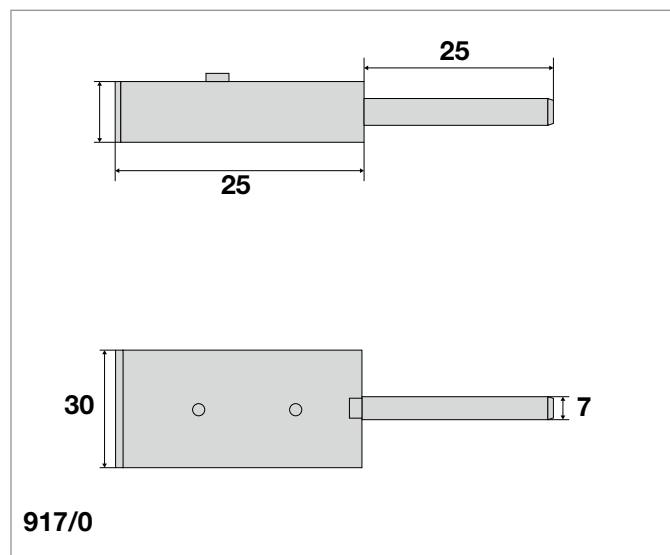
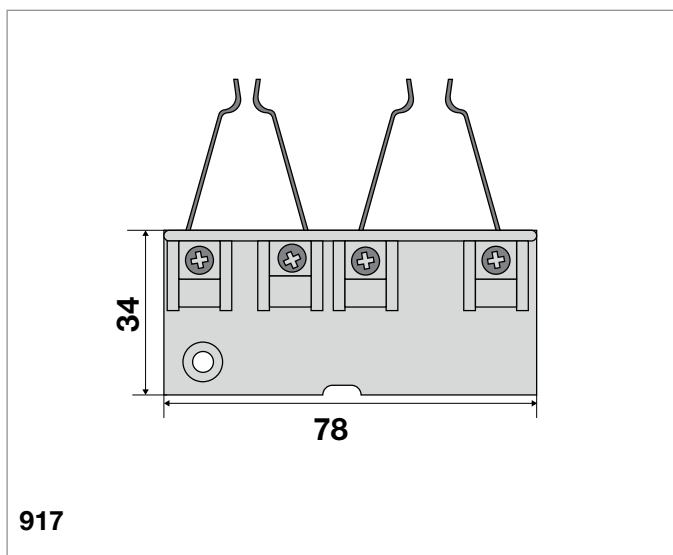
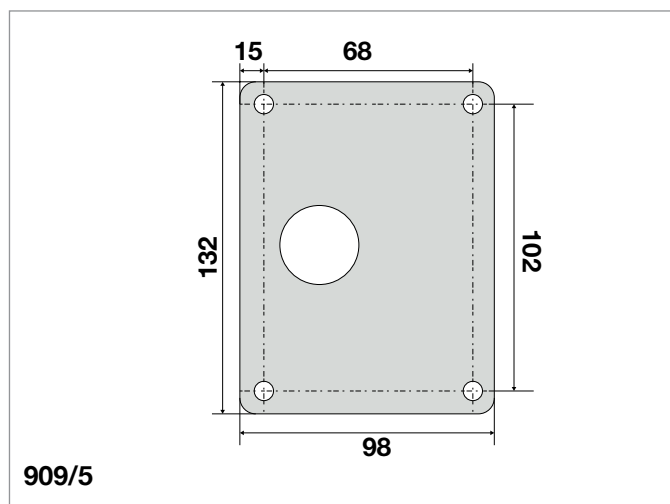
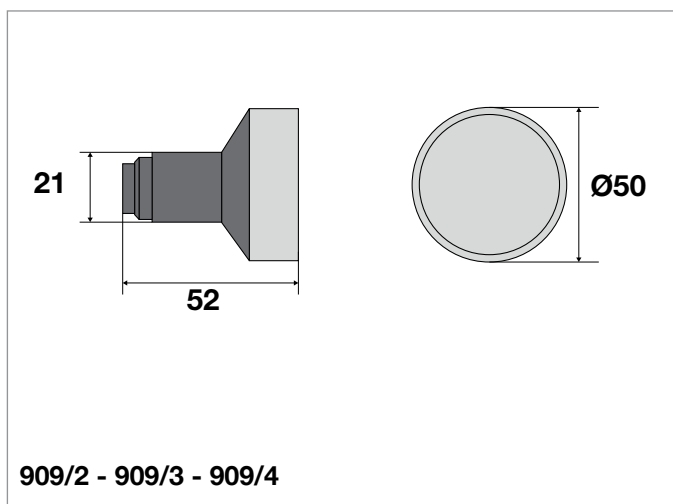

Codice / Code	Descrizione
909/2	Pomolo finitura anodizzata
909/3	Pomolo finitura cromata
909/4	Pomolo finitura ottonata
909/5	Coperchio serratura
917	Contatto blocco serratura
917/0	Catenaccio serratura omologata

RICAMBI PER SERRATURA DMG SPARE PARTS FOR DMG DOOR LOCKS

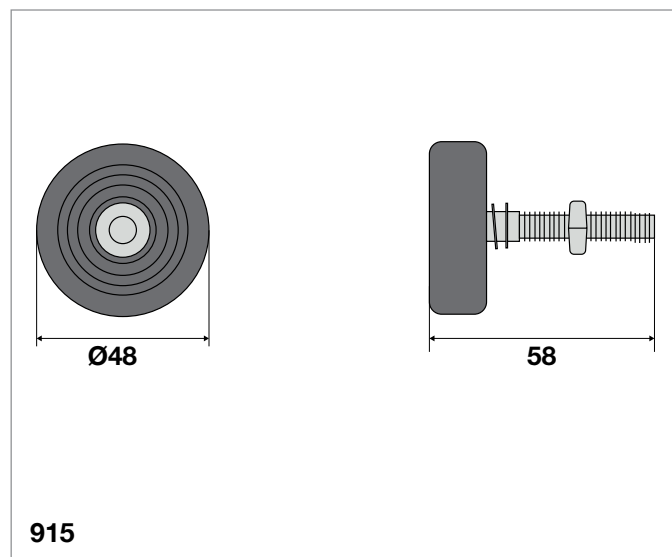
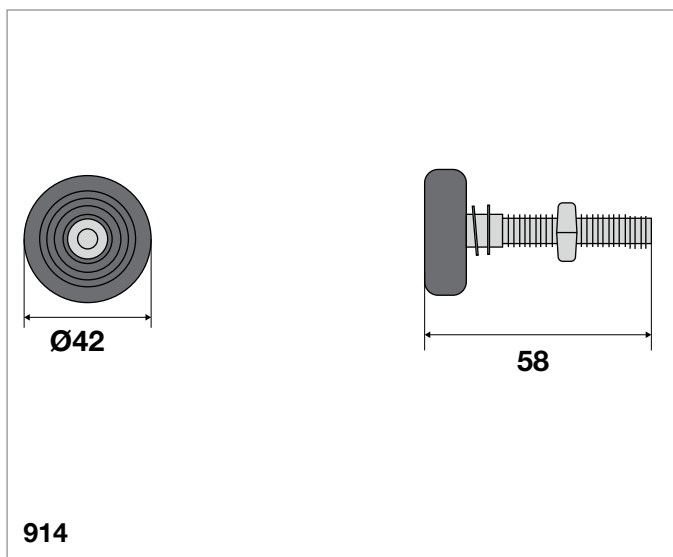
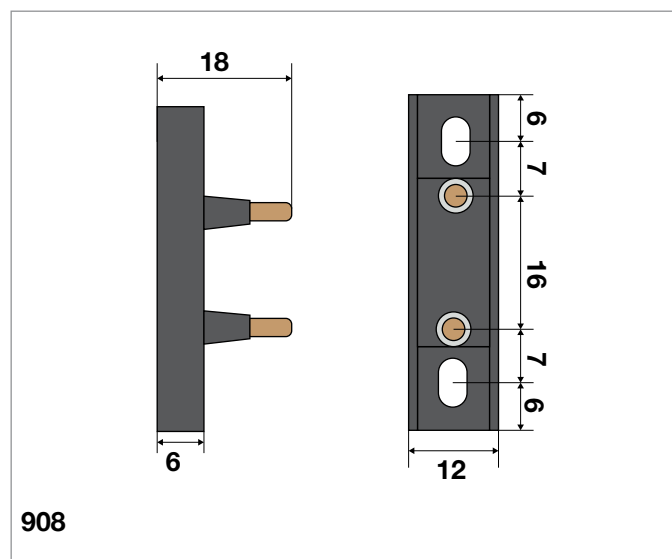
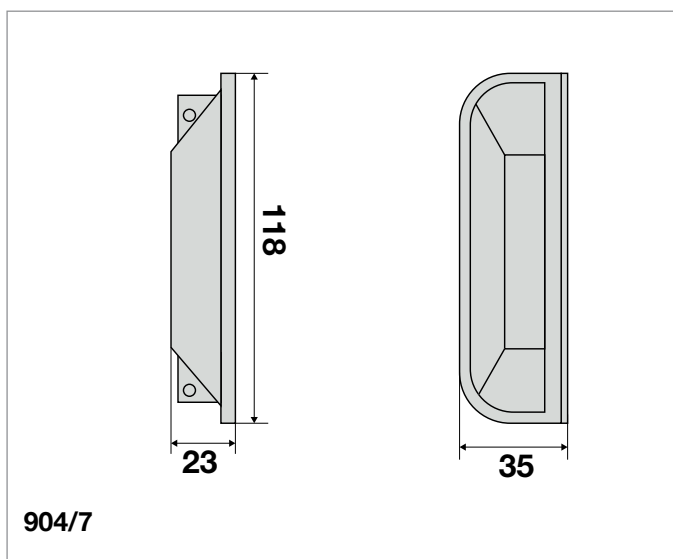

Codice / Code	Descrizione
904/7	Maniglia ad incasso a tirare per codice 904/4
908	Ponte asportabile
914	Ruota con perno Ø 42 mm
915	Ruota con perno Ø 48 mm

RICAMBI PER SERRATURA DMG SPARE PARTS FOR DMG DOOR LOCKS

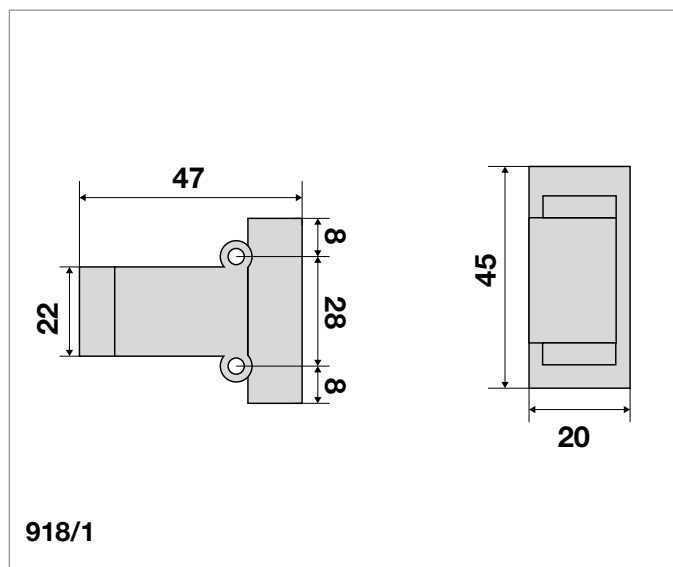
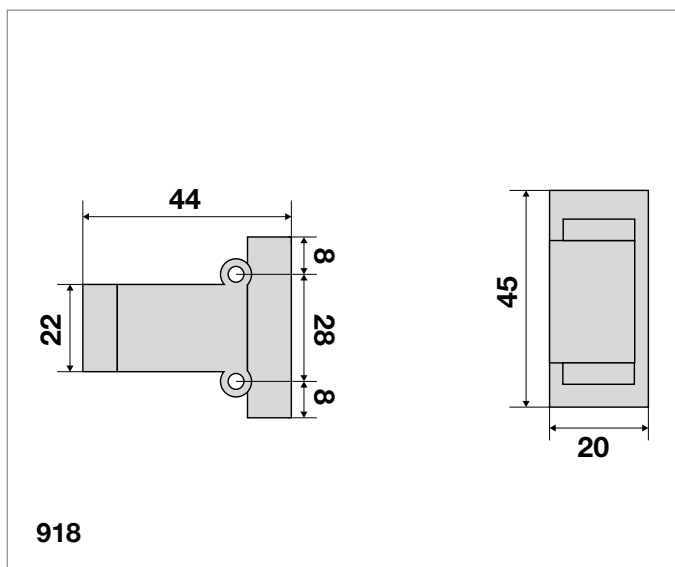
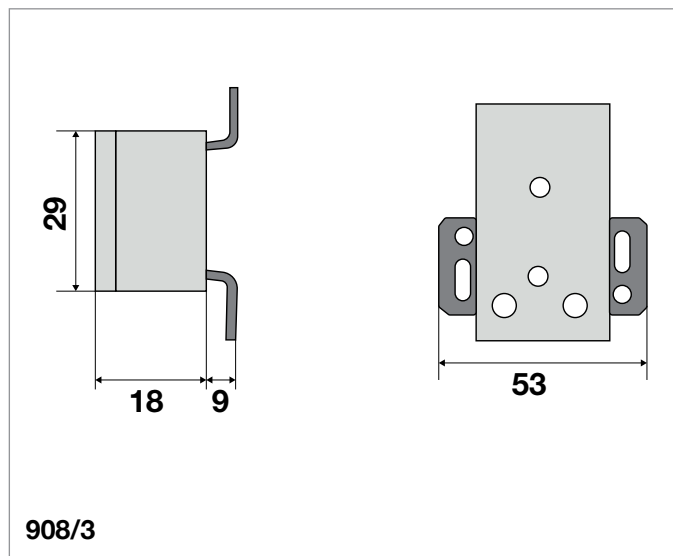
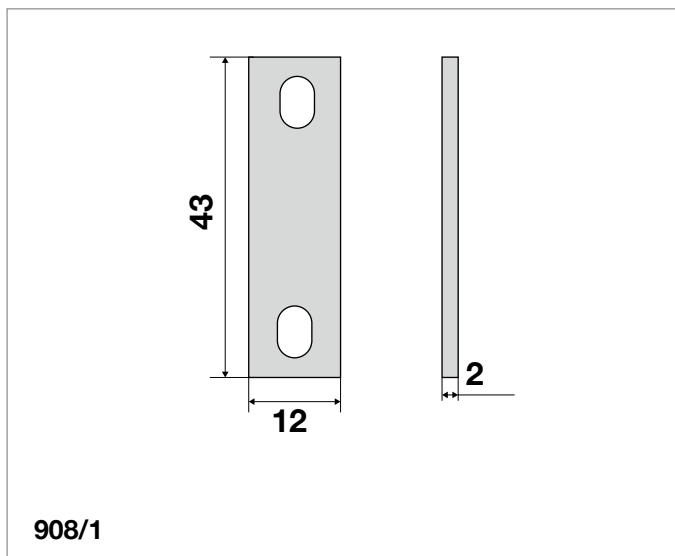

Codice / Code	Descrizione
908/1	Distanziale ponte asportabile
908/3	Contatto serratura
918	Contatto parte mobile per serratura non omologata
918/1	Contatto parte mobile per serratura omologata

RICAMBI PER SERRATURA DMG SPARE PARTS FOR DMG DOOR LOCKS

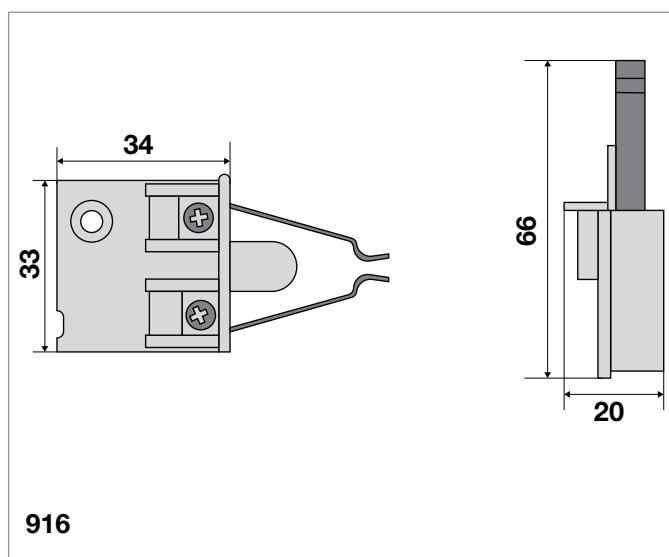
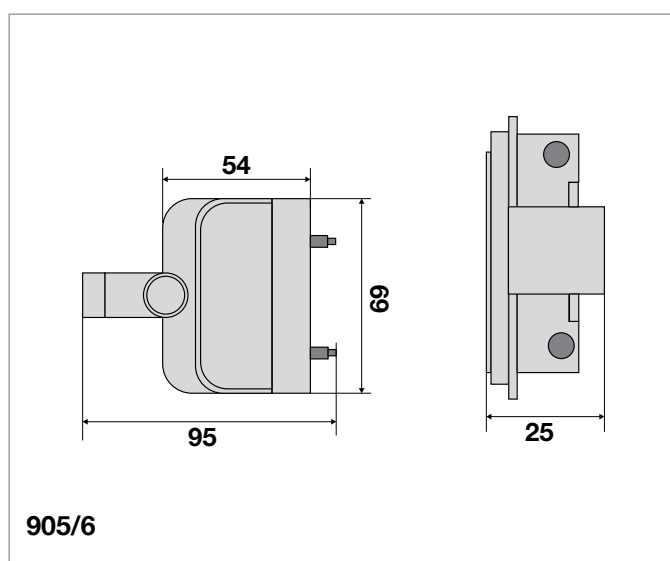
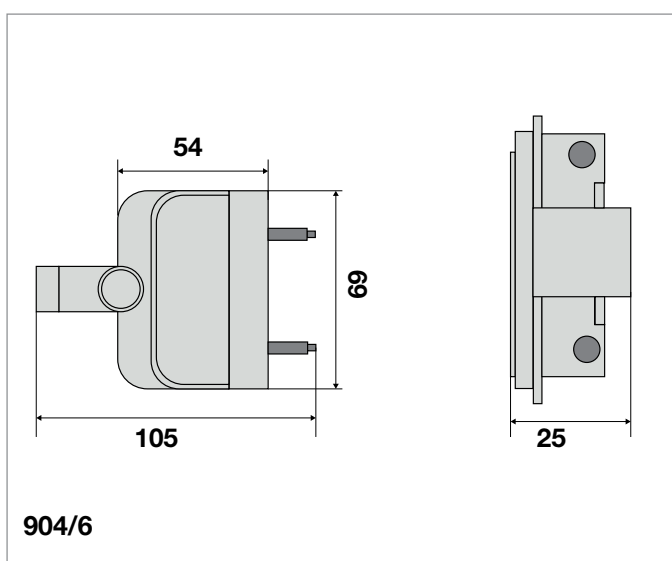
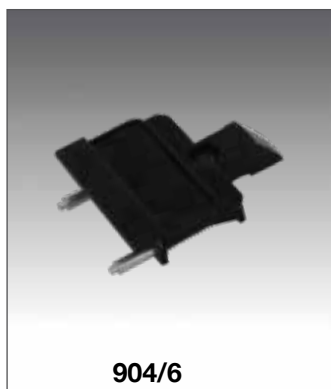

Codice / Code	Descrizione
904/6	Catenaccio in nylon per parte meccanica serratura codice 904/4 - 907
905/6	Catenaccio in nylon per parte meccanica serratura codice 905/4
908/2	Chiave serratura N°B3132
916	Contatto preliminare

RICAMBI PER SERRATURA ORIGINALE FIAM SPARE PARTS FOR FIAM ORIGINAL DOOR LOCKS



926/9



926/10



926/11



926/12

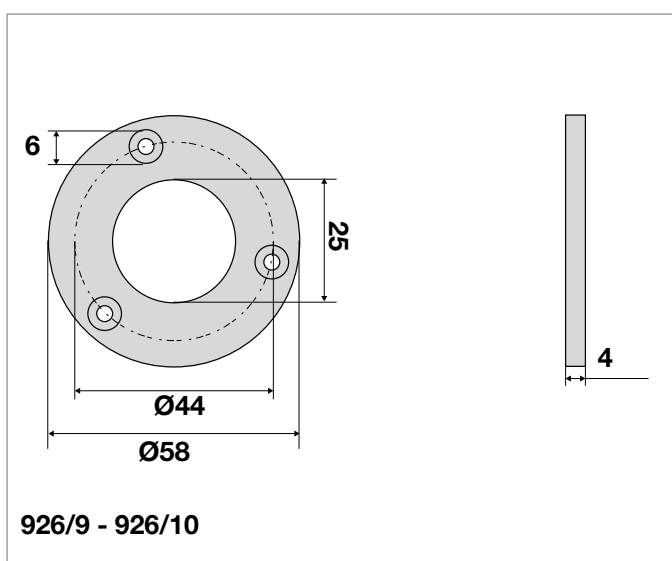

926/9 - 926/10

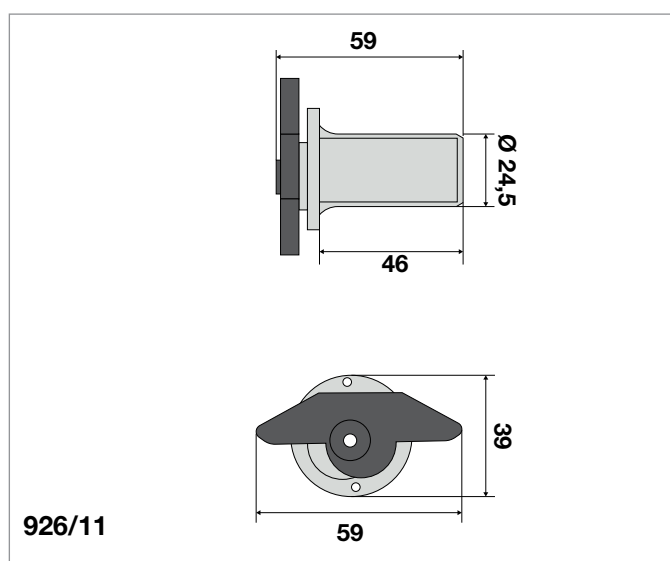

926/11

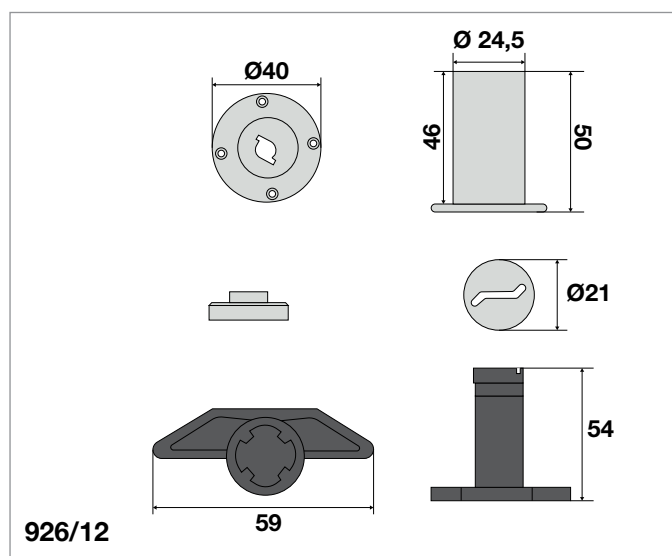

926/12

Codice / Code	Descrizione
926/9	Rosetta ottone cromato
926/10	Rosetta ottone lucido
926/11	Bocchetta chiave YALE completa di chiave per serratura 1B61
926/12	Bocchetta chiave FIAM per serratura 1B61

RICAMBI PER SERRATURA ORIGINALE FIAM SPARE PARTS FOR FIAM ORIGINAL DOOR LOCKS



926/15



926/21



926/22



926/23

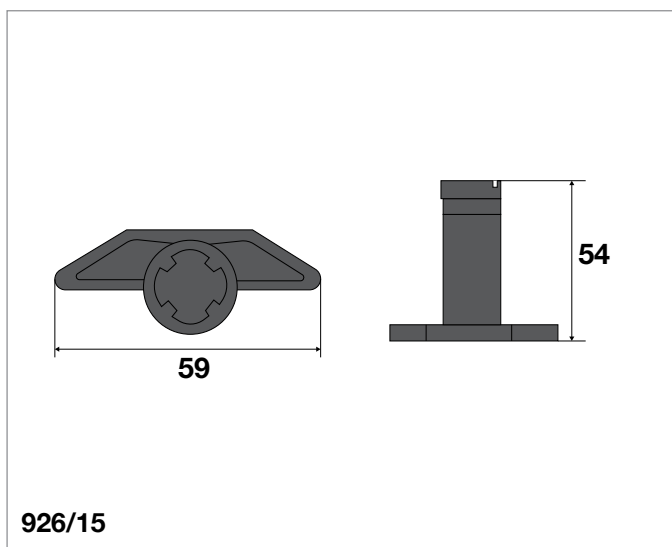

926/15

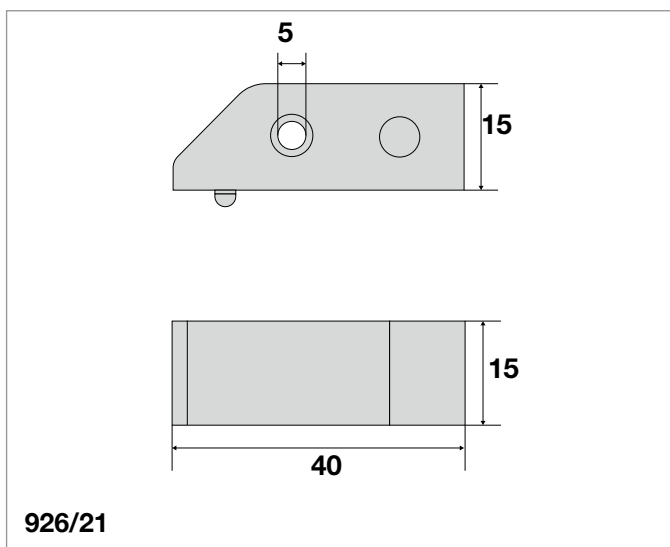

926/21

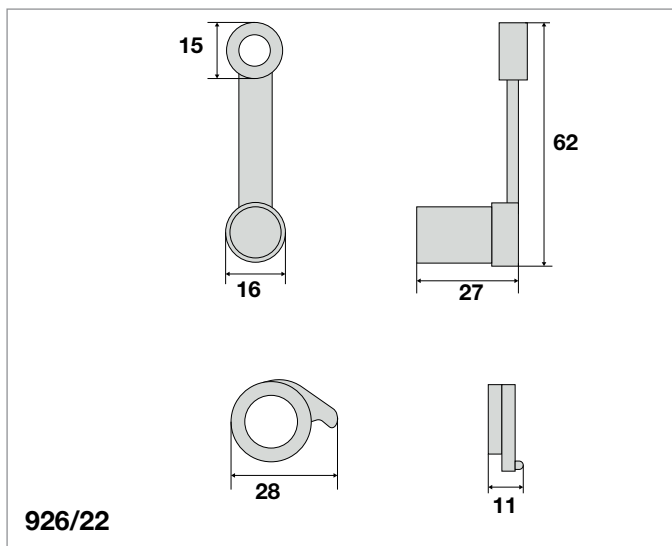

926/22

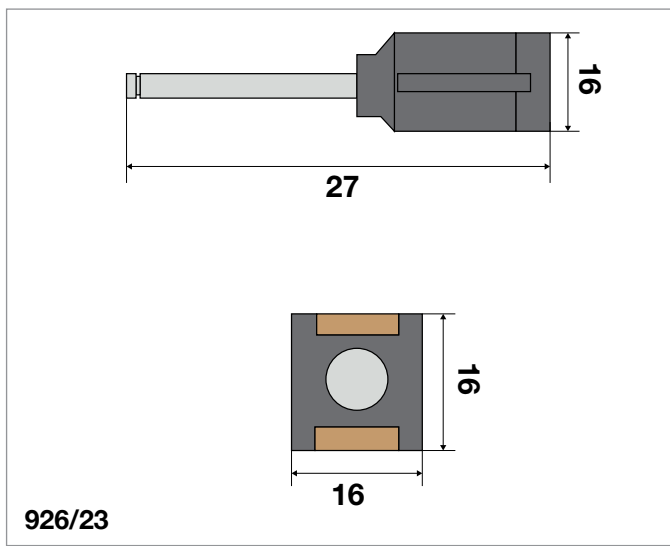

926/23

Codice / Code	Descrizione
926/15	Camma comando maniglia a pomolo
926/21	Basetta laterale lato preliminare
926/22	Leva interna con camma
926/23	Preliminare completo

RICAMBI PER SERRATURA ORIGINALE FIAM
SPARE PARTS FOR FIAM ORIGINAL DOOR LOCKS

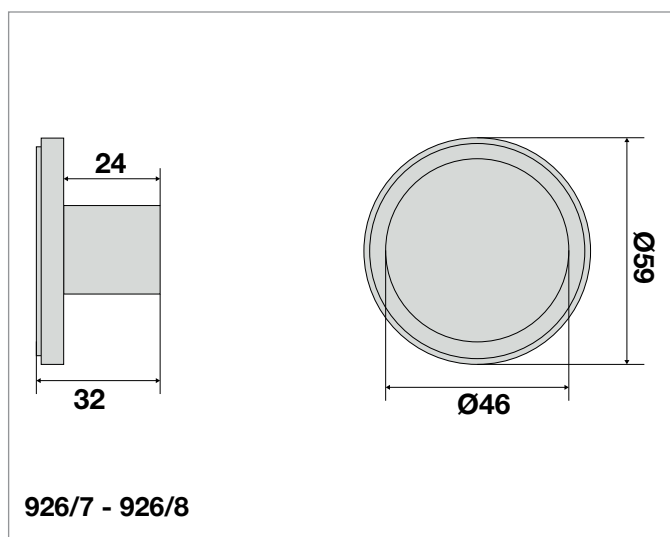
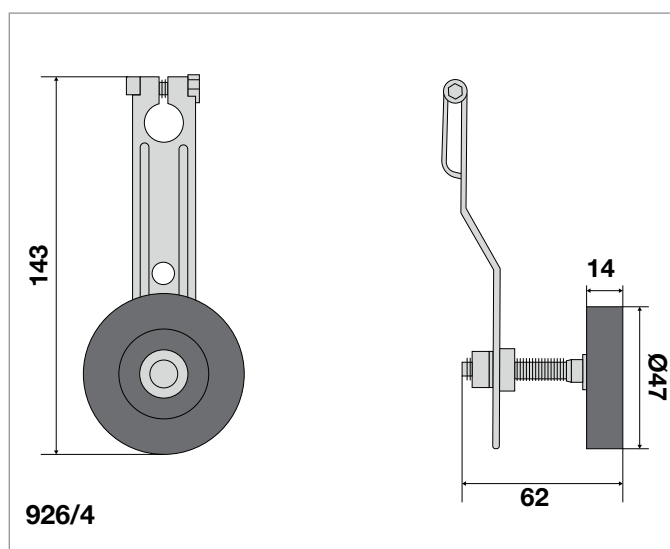
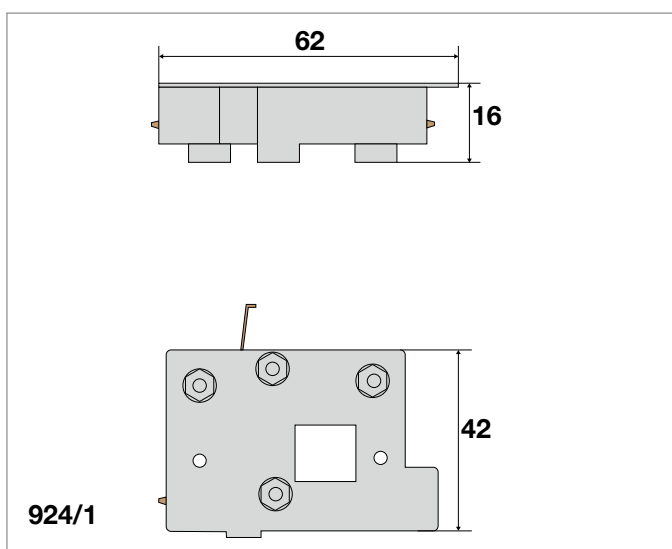

Codice / Code	Descrizione
924/1	Basetta centrale serratura omologata
926/4	Leva con rotella
926/7	Pomolo ottone cromato
926/8	Pomolo ottone lucido
926/19	Basetta centrale serratura non omologata

RICAMBI PER SERRATURA ORIGINALE FIAM
SPARE PARTS FOR FIAM ORIGINAL DOOR LOCKS

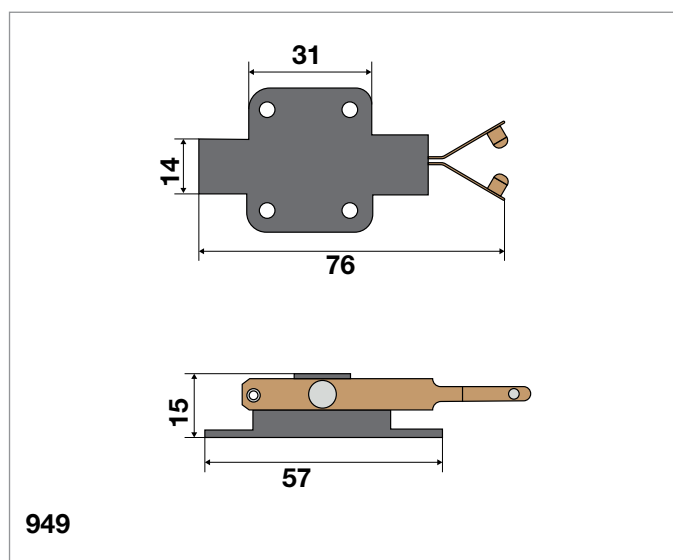
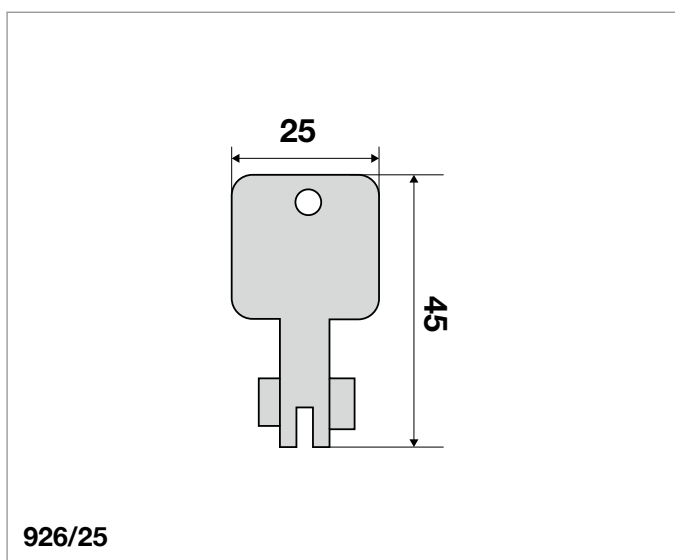
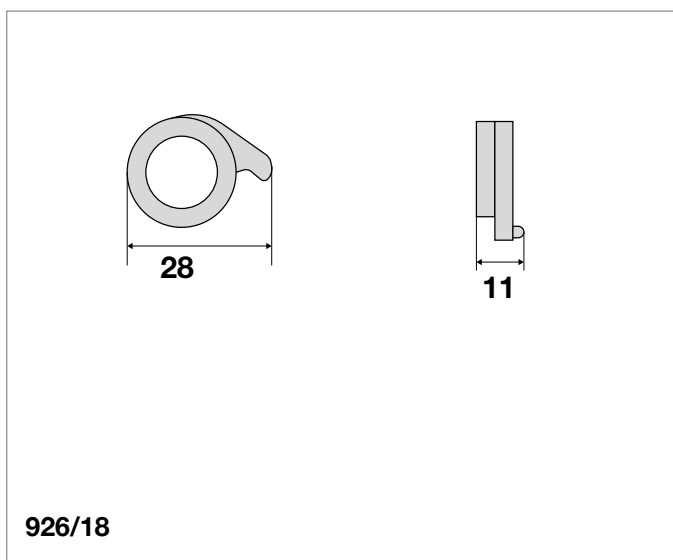
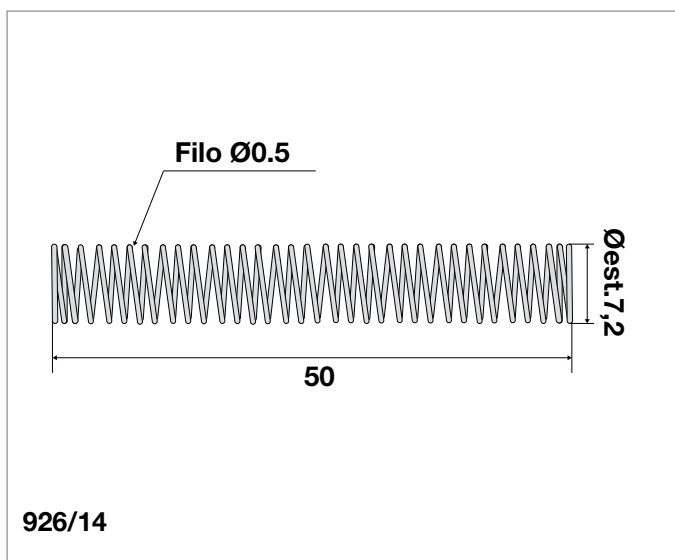

14

Codice / Code	Descrizione
926/14	Molla per preliminarare
926/18	Camma leva interna
926/25	Chiave serratura 1B61
949	Riscontro catenaccio

RICAMBI PER SERRATURA ORIGINALE FIAM SPARE PARTS FOR FIAM ORIGINAL DOOR LOCKS

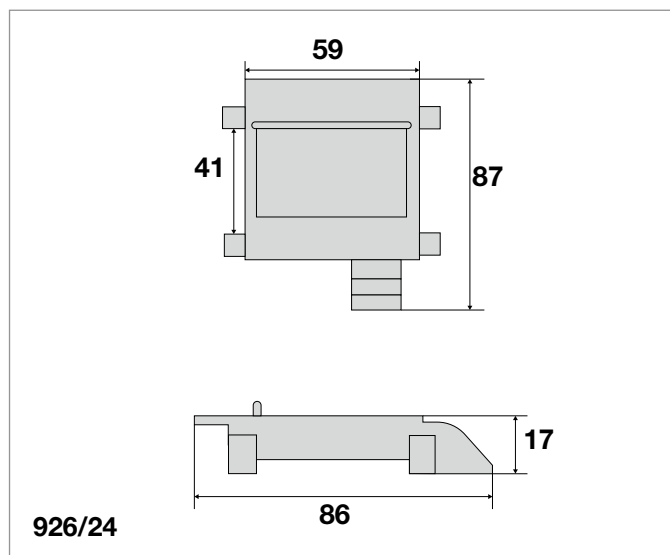
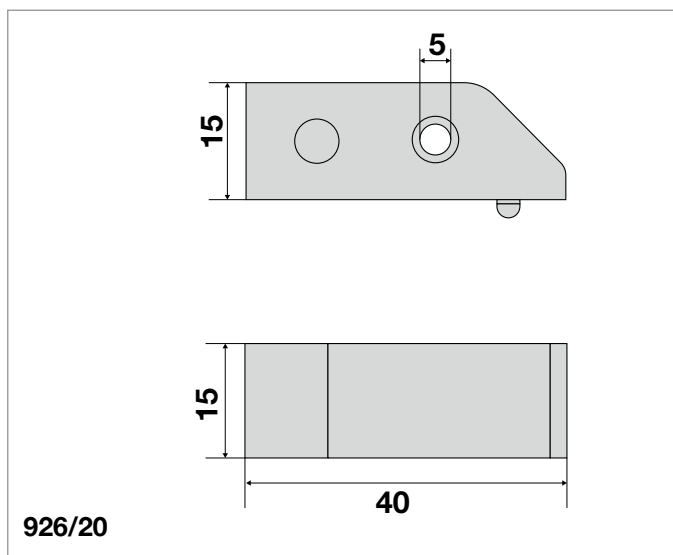
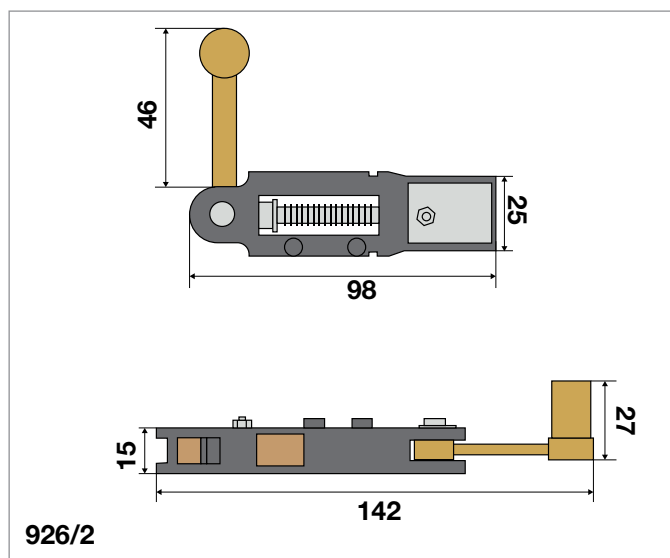
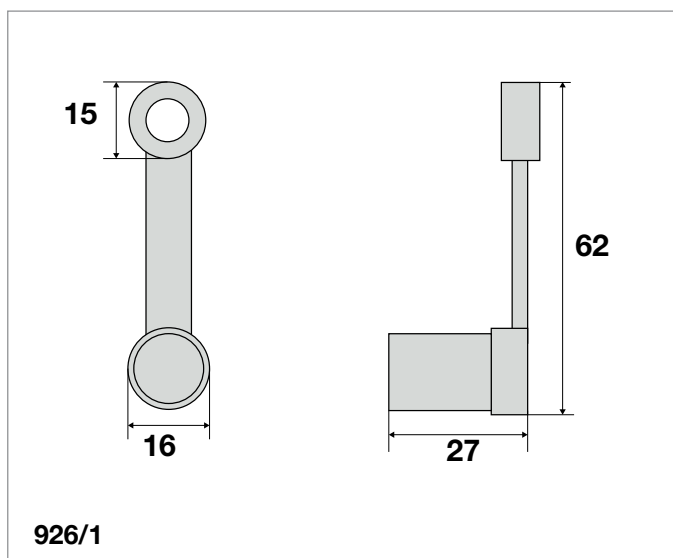

Codice / Code	Descrizione
926/1	Solo leva
926/2	Solo catenaccio
926/20	Basetta laterale lato catenaccio
926/24	Maniglia parte mobile

RICAMBI PER SERRATURA ORIGINALE FIAM SPARE PARTS FOR FIAM ORIGINAL DOOR LOCKS



925



926/5



926/13

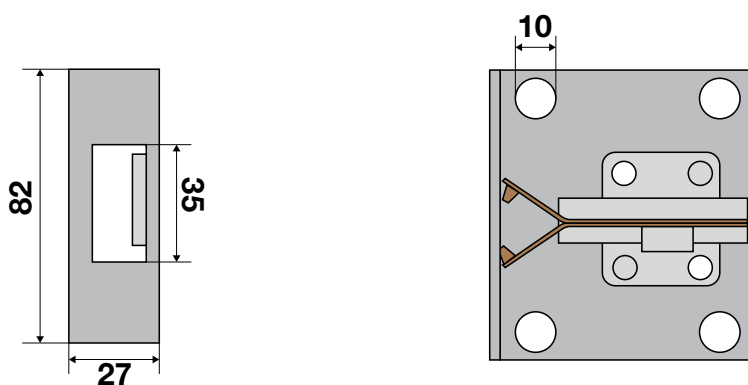

925

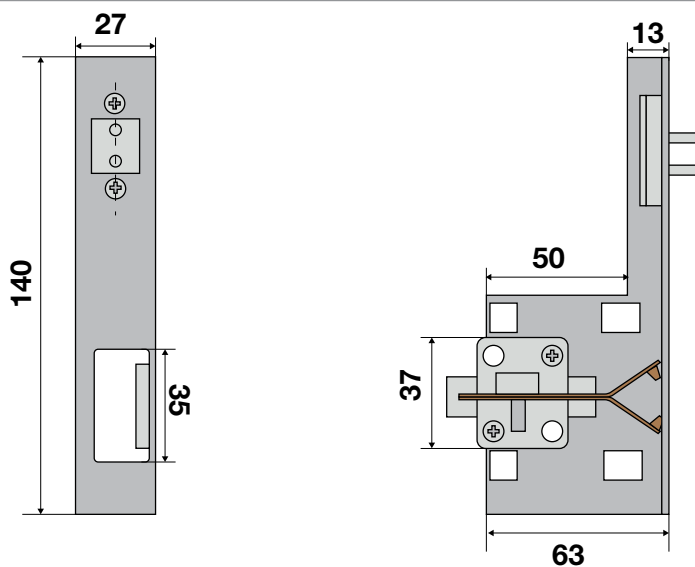

926/5

Codice / Code	Descrizione
925	Serratura tipo FIAM semiautomatica con emergenza
926/5	Solo parte mobile serratura premontata FIAM
926/13	Levetta a triangolo per stacco emergenza

RICAMBI PER SERRATURA ORIGINALE FIAM SPARE PARTS FOR FIAM ORIGINAL DOOR LOCKS

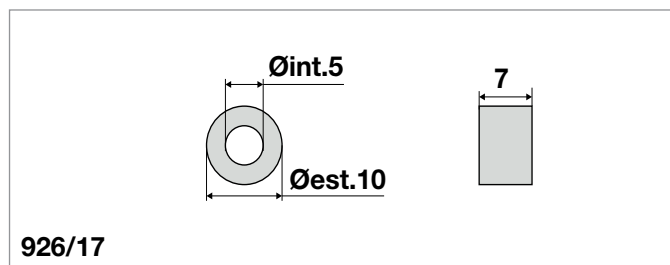
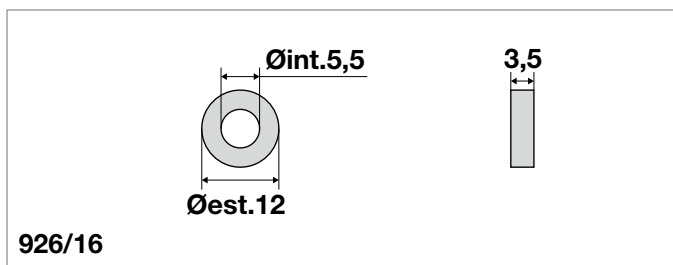
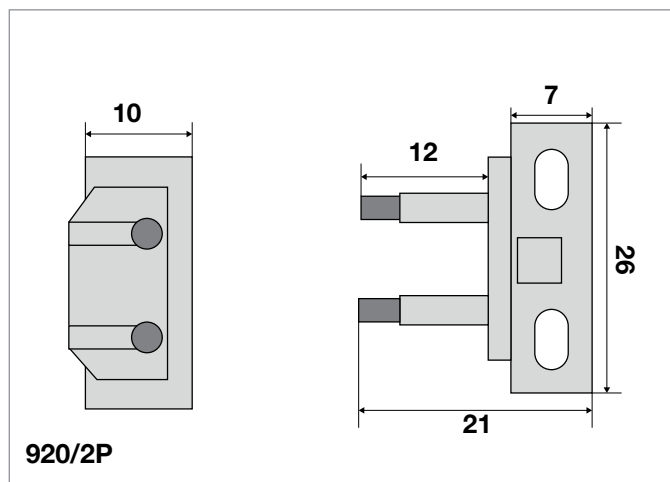
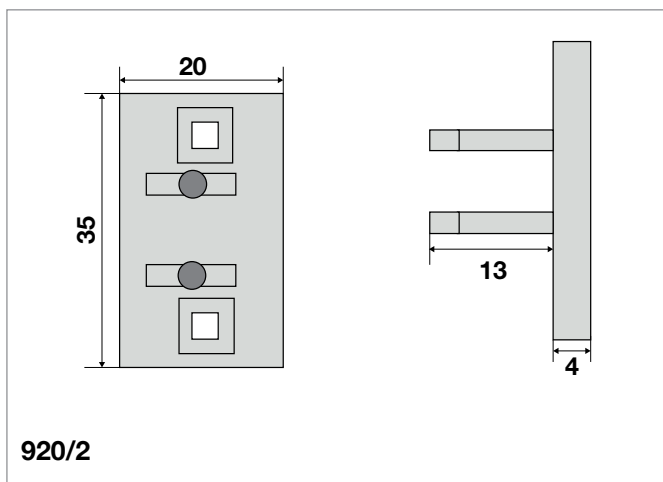
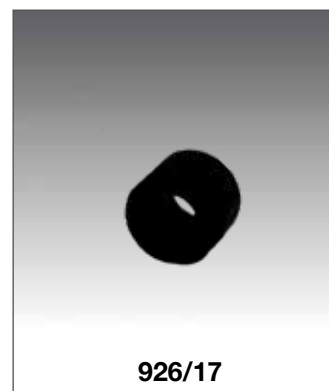

Codice / Code	Descrizione
920/2	Ponte per serratura semiautomatica
920/2P	Ponte per serratura a pomolo
926/16	Tampone in gomma preliminare
926/17	Tampone di fermo maniglia

BLOCCHETTO PER CHIAVE EMERGENZA PER SERRATURE DIVERSE
EMERGENCY KEY BLOCK FOR VARIOUS LOCKS

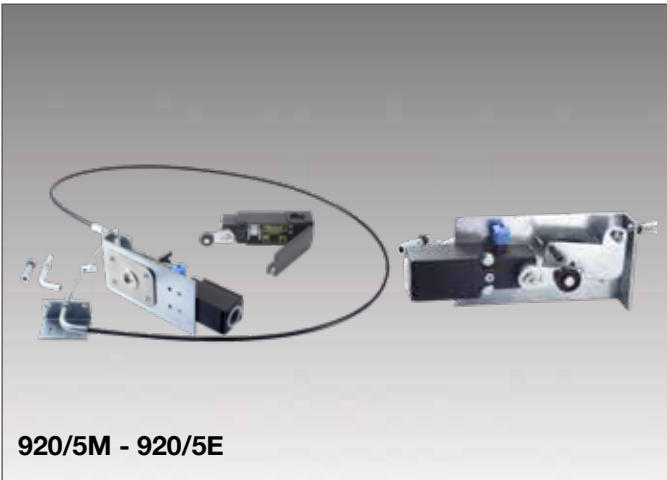

Codice / Code	Descrizione
920/5M	Apertura di emergenza con monitoraggio per EN81-21 con riarmo manuale
950/5E	Apertura di emergenza con monitoraggio per EN81-21 con riarmo elettrico tensioni: 24 VDC - 48 VDC - 230 VAC
926/29	Dispositivo per chiave di emergenza, sul volantino del portale, modello FIAM
994/BCE	Blocchetto chiave emergenza triangolare FIAM

BLOCCO CHIAVE EMERGENZA PER SERRATURA KRONENBERG KRONENBERG EXTERNAL EMERGENCY RELEASE & DOOR INTERLOCKS



NE-00-R(L)



NE-02-IP67-R(L)



NE-11-EX-2(4)-R(L)



N21-11 AEO

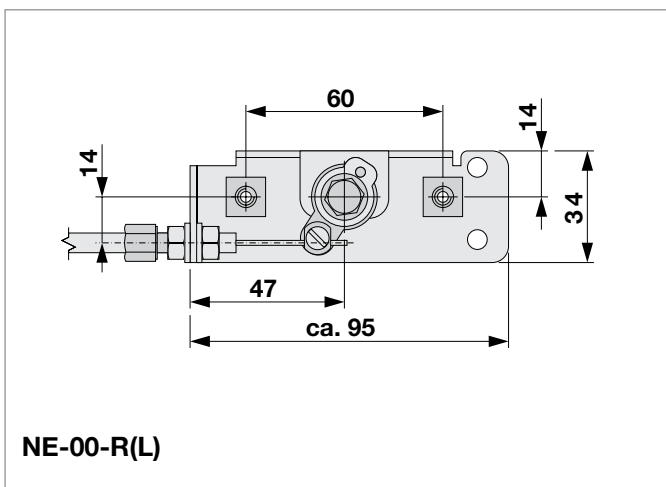

NE-00-R(L)

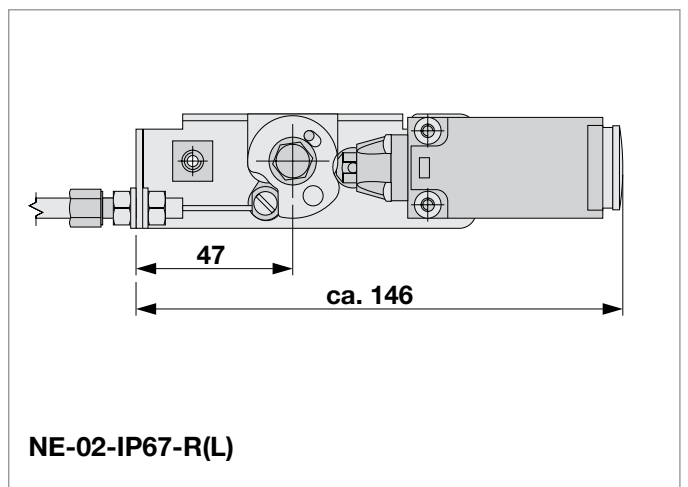

NE-02-IP67-R(L)

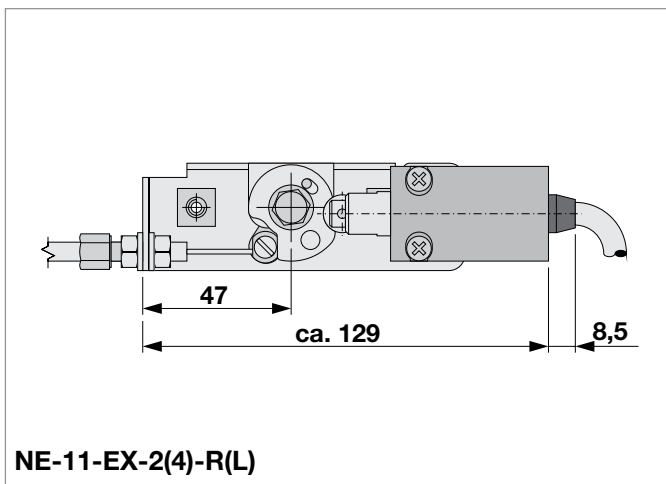

NE-11-EX-2(4)-R(L)

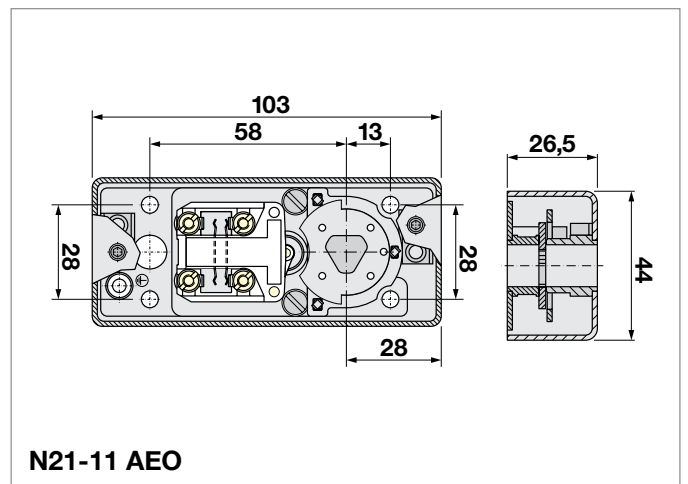

N21-11 AEO

Codice / Code	Descrizione
NE-00-R(L)	Blocco chiave emergenza a incasso con azionamento a cavo destro (R), sinistro (L)
NE-02-IP67-R(L)	Blocco chiave emergenza a incasso con azionamento a cavo destro (R), sinistro (L), IP67 con segnale (2NC)
NE-11-EX-2(4)-R(L)	Blocco chiave emergenza incasso con azionamento a cavo destro (R), sinistro (L), IP65 con segnale (1NC+1NC)
N21-11 AEO	Blocco chiave emergenza da sovrapposizione da montare in corrispondenza foro di accesso della serratura con perno a triangolo della serratura in opera destro (R), sinistro (L) con segnale elettrico (1NC)

PARTICOLARI PER SERRATURA KRONENBERG PARTICULAR FOR KRONENBERG DOOR LOCKS



980/A



980/1



981



981/1

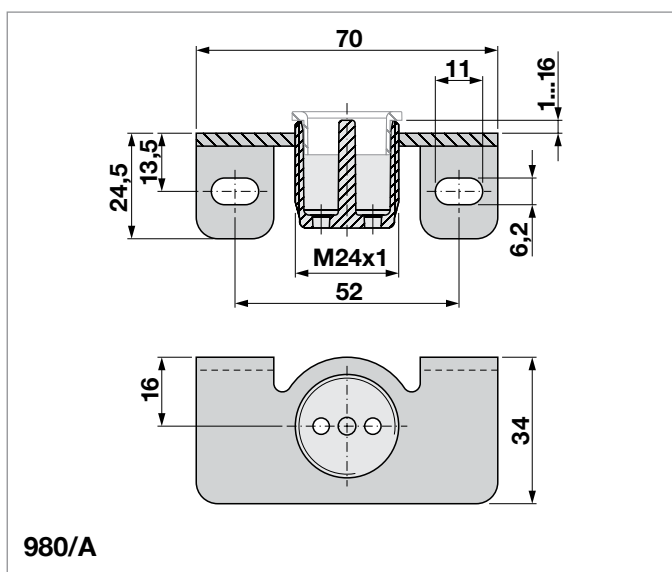

980/A

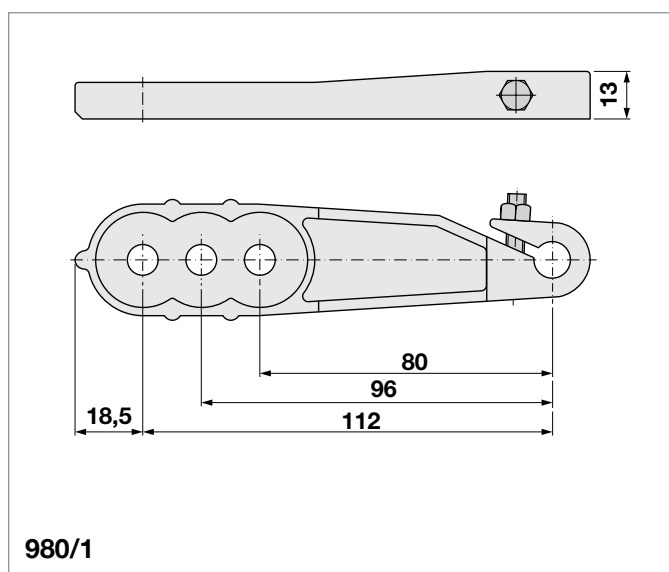

980/1

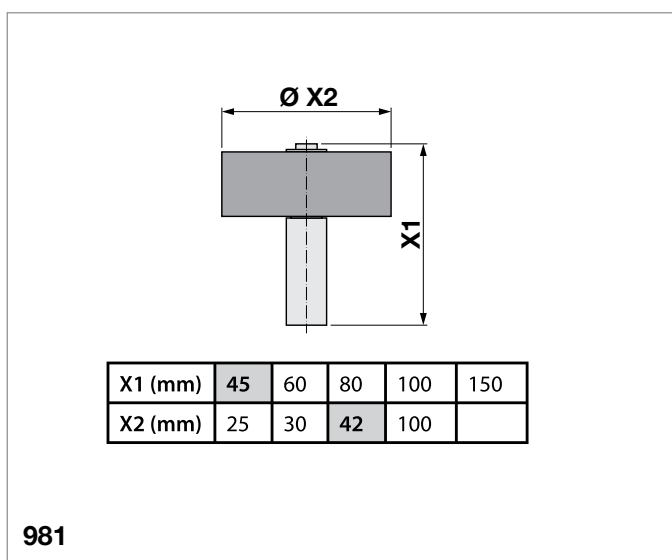

981

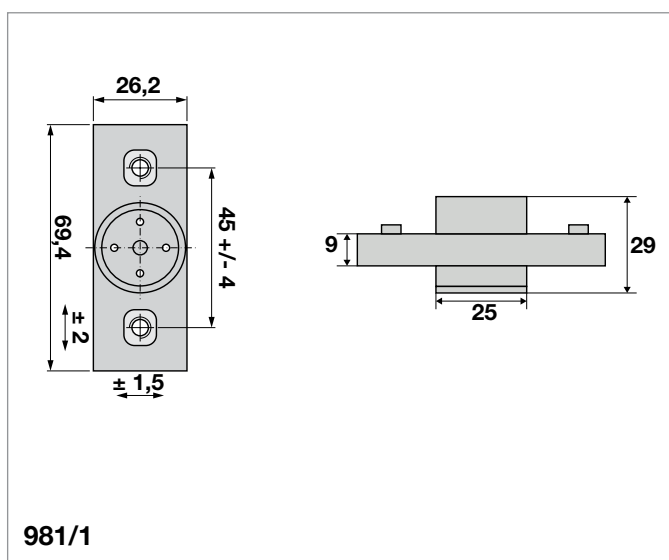

981/1

Codice / Code	Descrizione
980/A	Riscontro a angolo serratura KRONENBERG
980/1	Leva serratura KRONENBERG senza rotella
981	Rotella con perno diametro 42mm KRONENBERG
981/1	Riscontro serratura KRONENBERG

RICAMBI INTERNI SERRATURA SCHINDLER ORIGINALI
SPARE PARTS FOR SCHINDLER ORIGINAL INTERNAL DOOR LOCKS

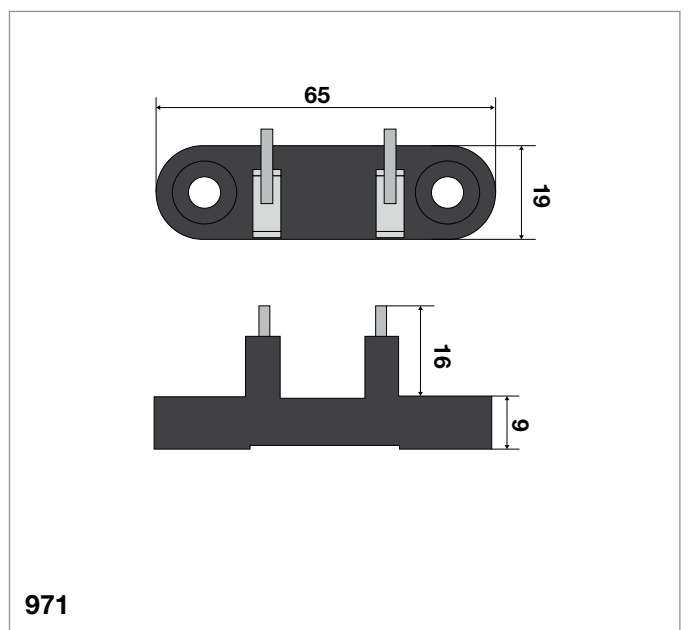
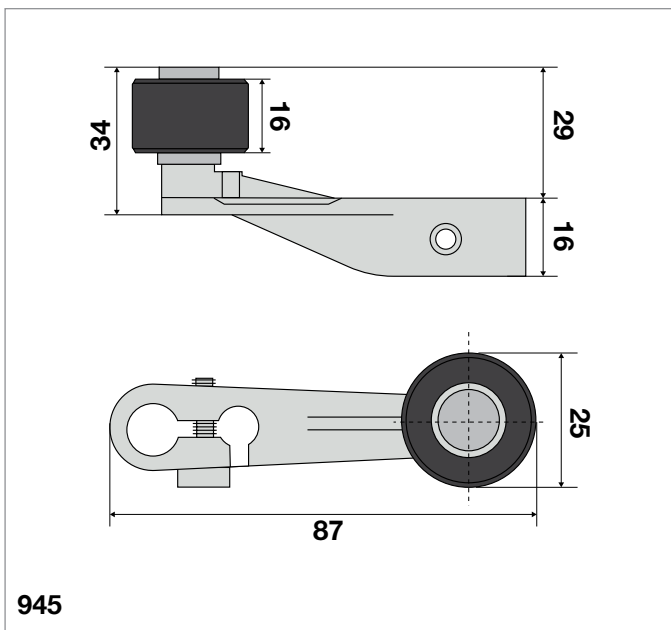
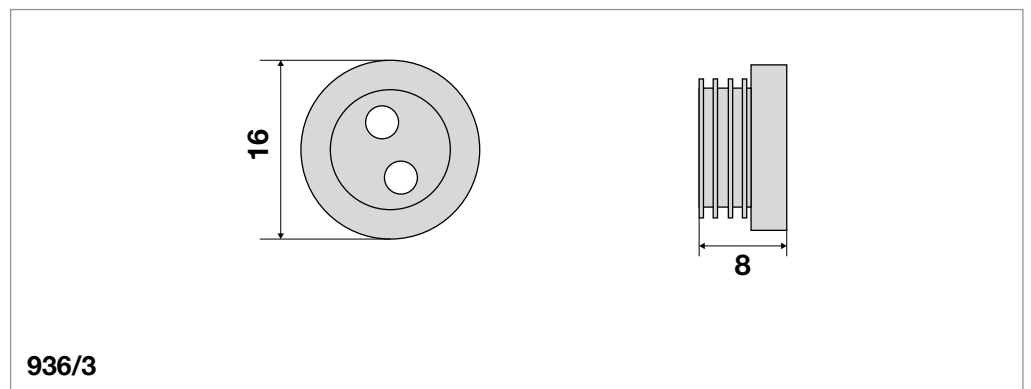
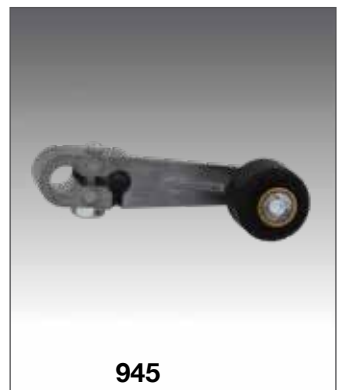
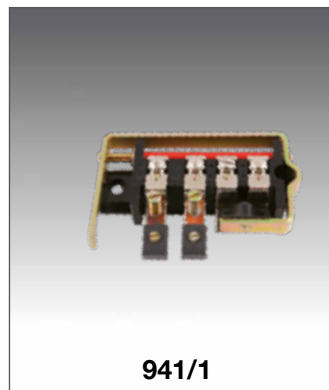
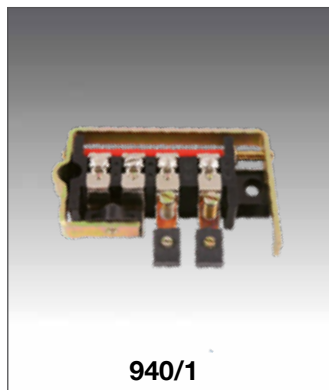

Codice / Code	Descrizione
936/3	Tappo emergenza porte semiautomatiche
940/1	Contatto serratura DX
941/1	Contatto serratura SX
945	Leva con ruota D.25
971	Ponte serratura

RICAMBI SERRATURA SEMIAUTOMATICA TF SPARE PARTS FOR TF SEMIAUTOMATIC DOOR LOCK



932



933



934



935

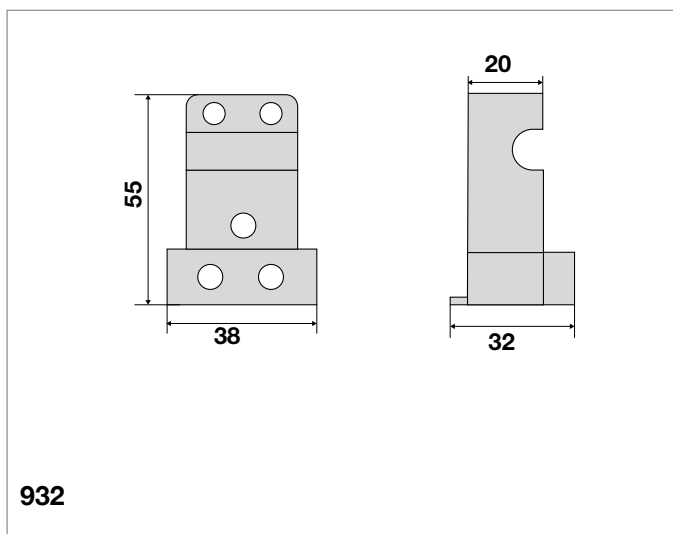

932

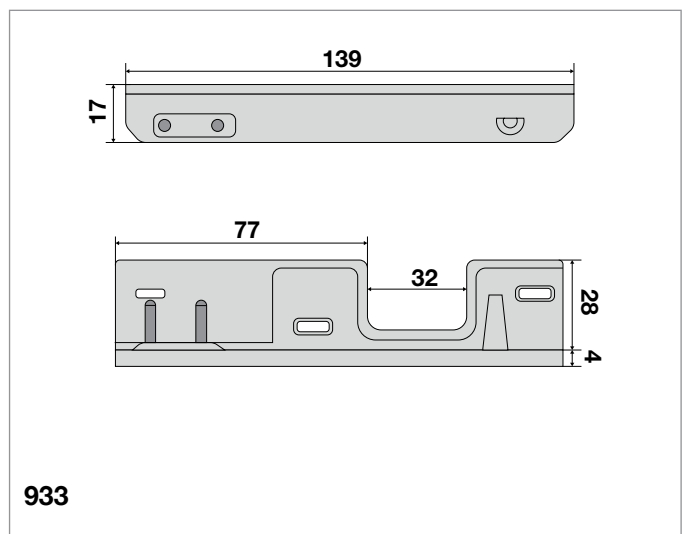

933

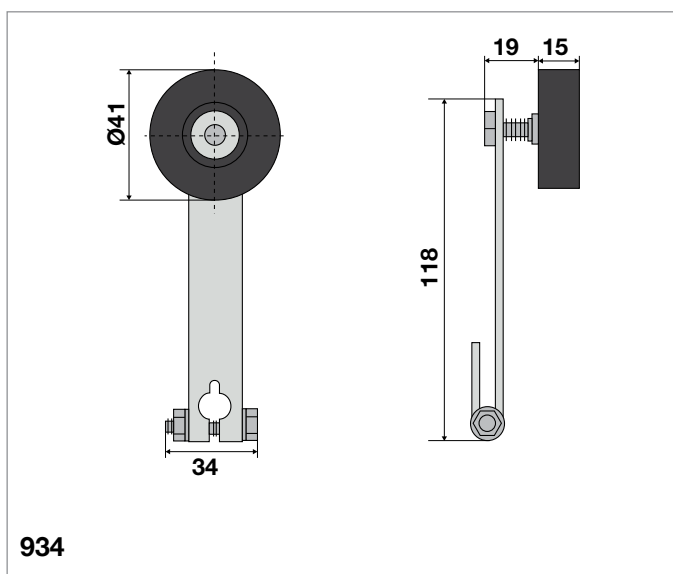

934

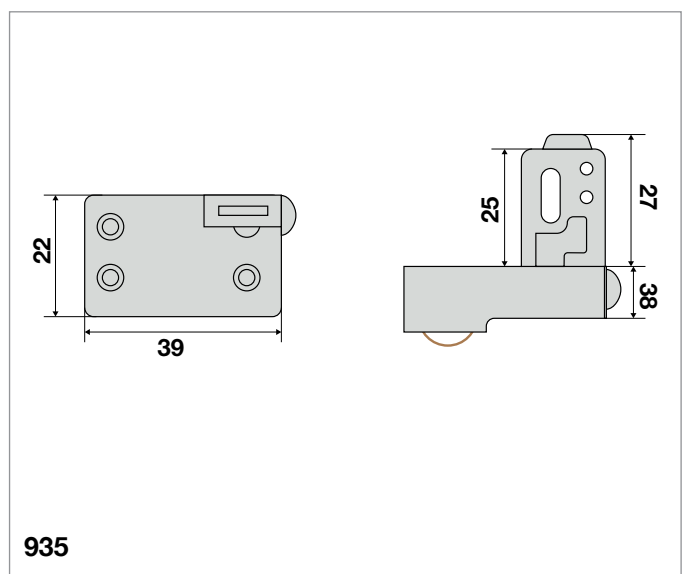

935

Codice / Code	Descrizione
932	Preliminare femmina serratura TF
933	Ponte maschio serratura TF
934	Leva con rotella serratura TF
935	Cursore serratura TF

RICAMBI SERRATURA SEMIAUTOMATICA TF SPARE PARTS FOR TF SEMIAUTOMATIC DOOR LOCK

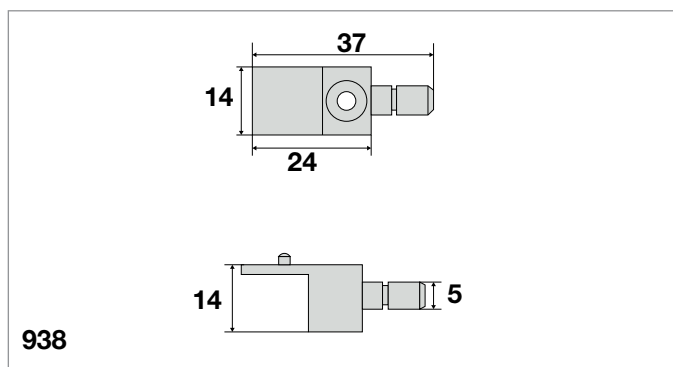
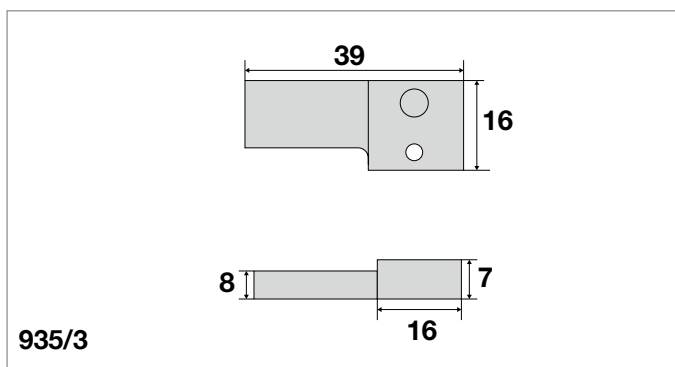
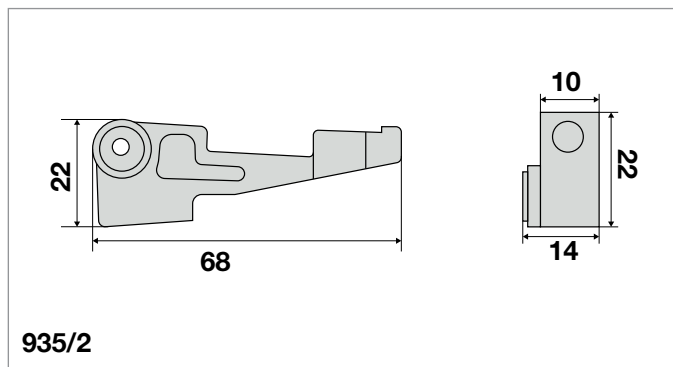
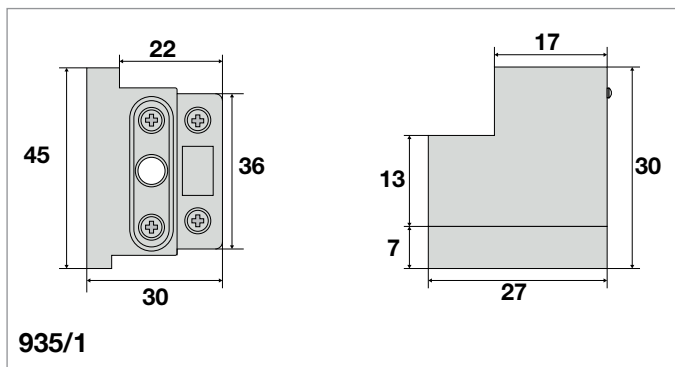
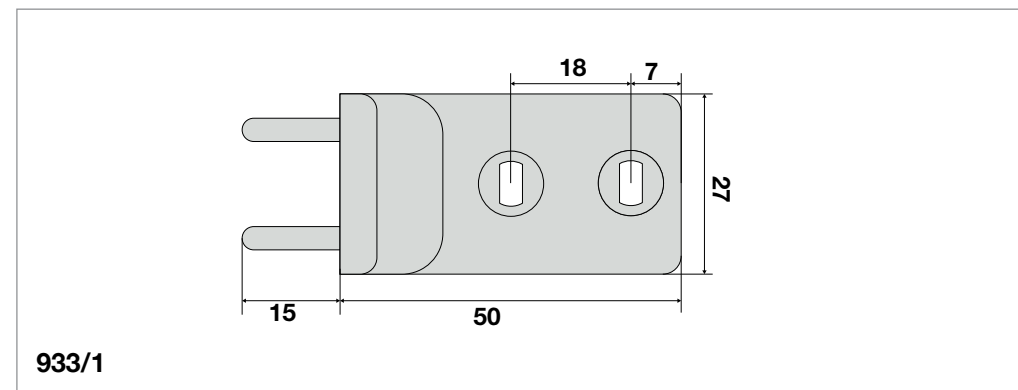
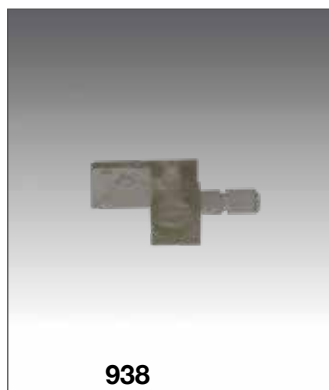
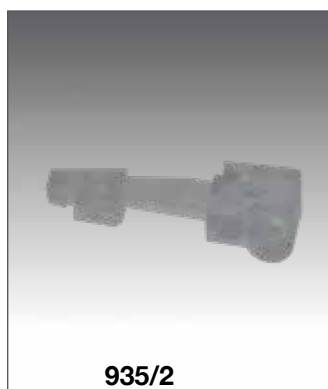
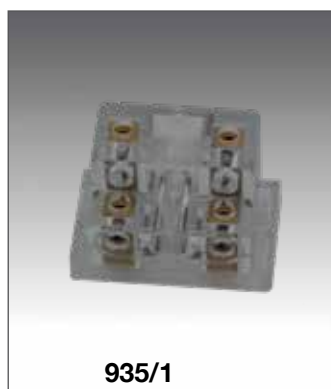

Codice / Code	Descrizione
933/1	Preliminare corto serratura TF
935/1	Basetta cursore serratura TF
935/2	Leva doppio blocco serratura TF
935/3	Fermo sicura serratura TF
938	Basetta doppio blocco serratura TF

FERODO - OLIATORI - STAFFE ED ANGOLARE PER OLIATORI
LUBRICATOR - OILERS - BRACKETS AND ANGLE BRACKET FOR OILERS

Ferodo senza amianto	15.2
<i>Lubricator free asbestos</i>	
Oliatore SCHINDLER, OTIS a feltrini flessibili e oliatore a botticella tipo FIAM	15.3
<i>SCHINDLER, OTIS oilers with flexible felts type FIAM</i>	
Olio e grasso	15.6
<i>Grease</i>	
Raccoglitore olio per guide	15.4
<i>Oil collector for guides</i>	
Staffe per oliatori	15.5
<i>Brackets for oilers</i>	

Note: I componenti sul catalogo con riportata una specifica marca di ascensore sono utilizzati abitualmente solo da questa marca. I particolari senza marca sono utilizzati da più marche di ascensori.

Note: The components in the catalogue with a specific lift brand are usually used only by the brand. Unbranded parts are used by multiple lift brands.

FERODO SENZA AMIANTO / *Lubricator free asbestos*

Il FERODO 3816F ha un coefficiente d'attrito elevato ed è particolarmente indicato nel settore ascensoristico, oltre all'uso in un'ampia gamma di applicazioni quali i freni industriali a ceppi e a nastro.

Disponibilità e gamma delle dimensioni Questo materiale è disponibile esclusivamente sotto forma di nastro in rotoli.		Dati Tecnici Coefficiente d'attrito	
Spessore	Da 3,17 mm a 19 mm	A secco	Statico 0,40 Dinamico 0,83
Larghezza del nastro	Da 12,7 a 508 mm		

Applicazioni
M10/1 ferodo 1000x95x6 mm
Freni a ceppi per impiego ascensoristico
Freni industriali a tamburo e a nastro
Svariate applicazioni in campo industriale

Caratteristiche fisiche		Condizioni di lavoro raccomandata	
Peso specifico	1,30 g/cm ³	Pressione specifica (dinamica)	70 : 790 KN/m ²
Massima resistenza alla trazione	23MN/m ²	Velocità massima di strascinamento	18 m/sec
Massima resistenza alla compressione	96,5 MN/m ²	Temperatura Massima	300°C
Massima resistenza al taglio	16,9 MN/m ²	Temperatura massima intermittente	200°C
Capacità di tenuta del ribattino	59,6 MN/m ²	Temperatura massima continua	150°C
Conduttività termica	0,76 W/m°C		

Per ordine si prega di utilizzare i seguenti codice	
M011/1 ferodo 1000 x 80 x 6 mm	M016 ferodo 1000 x 50 x 6,35 mm
M012/1 ferodo 1000 x 70 x 6 mm	M017 ferodo 1000 x 82 x 8 mm
M013/1 ferodo 1000 x 100 x 6 mm	M018 ferodo 1000 x 90 x 6,35 mm
M014/1 ferodo 1000 x 60 x 6 mm	M018/1 ferodo 1000 x 90 x 6 mm
M015 ferodo 1000 x 120 x 6,35	M020 taglio su misura ferodo
M015/1ferodo 1000 x 120 x 6 mm	

Incollaggio

Il ferodo 3816F può essere incollato con qualsiasi adesivo, tra quelli già affermati nel settore specifico, anche se i migliori risultati si ottengono con quelli termoindurenti.

Quindi devono poi essere incollate delle guarnizioni ad arco, nell'ordine si deve specificare quale delle due superfici deve essere preparata per l'incollaggio del FERODO durante la fabbricazione; altrimenti la superficie di incollaggio può essere preparata mediante rettifica, sabbiatura, pallinatura, smerigliatura a nastro, ecc...

OLIATORI OILERS



12402



12403



12403/1

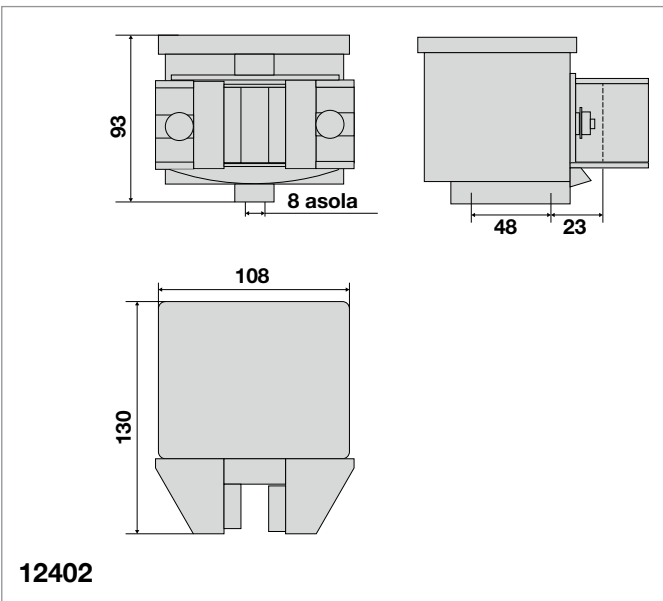

12402

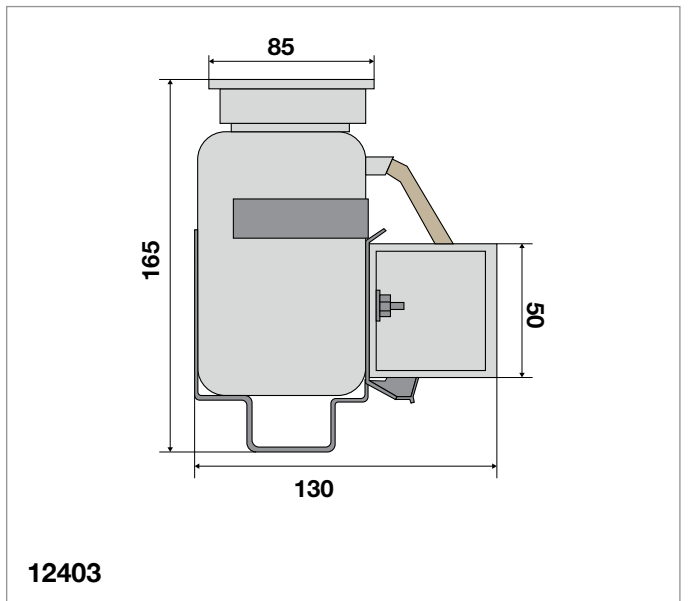

12403

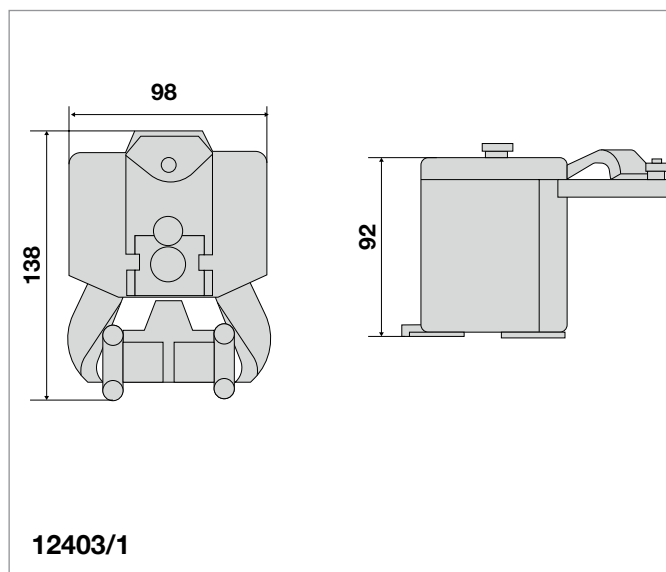

12403/1

Codice / Code	Descrizione
12402	Oliatore standard intercambiabile SCHINDLER
12403	Oliatore a botticella tipo FIAM
12403/1	Oliatore feltri "flessibili" tipo OTIS

RACCOGLITORE OLIO PER GUIDE OIL COLLECTOR FOR GUIDES



12400



12400/1

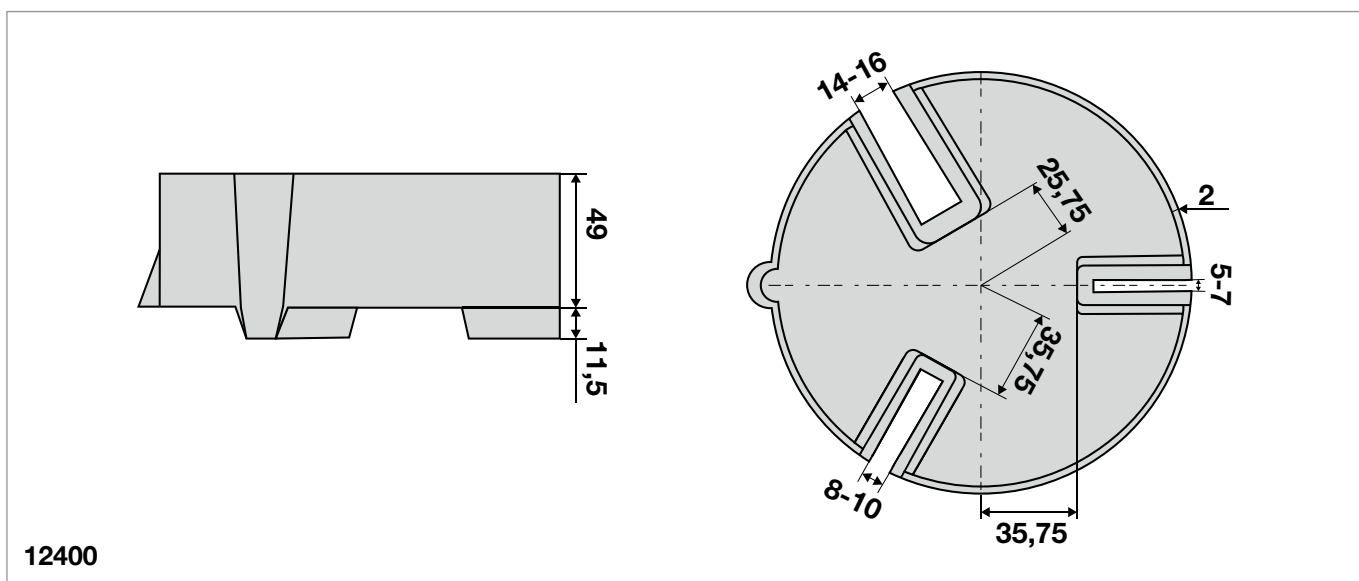

12400

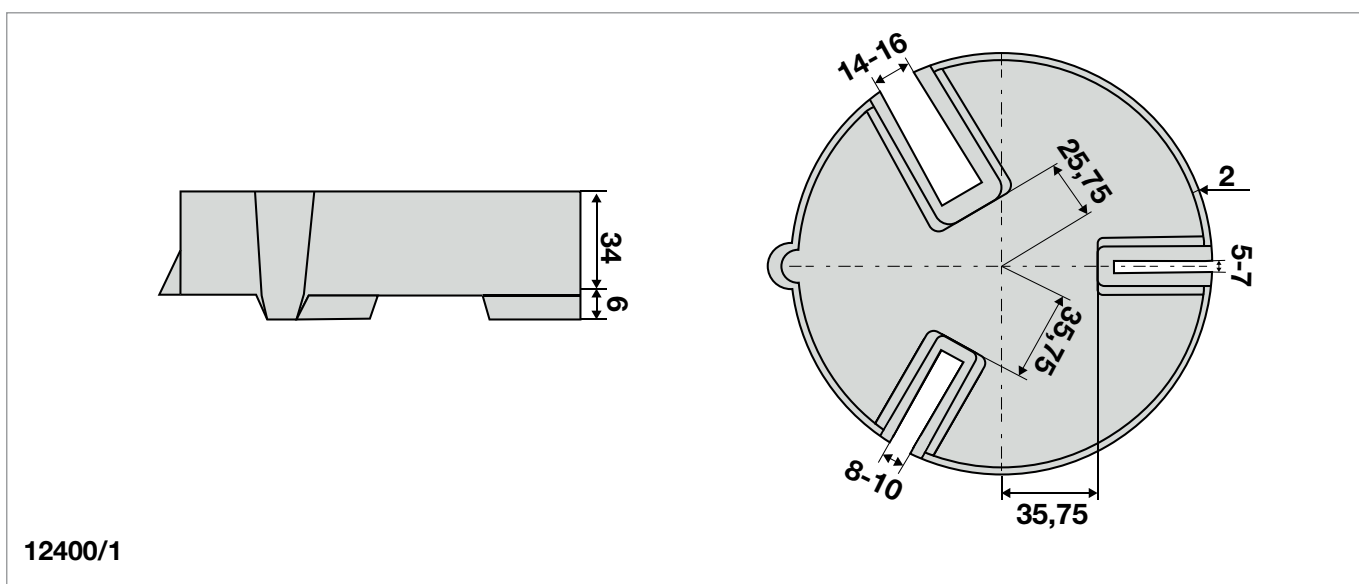

12400/1

15

Codice / Code	Descrizione
12400	Raccoglitore olio h.49 per guide 5-7 8-10 14-16
12400/1	Raccoglitore olio h.34 per guide 5-7 8-10 14-16

STAFFE PER OLIIATORI BRACKETS FOR OILERS

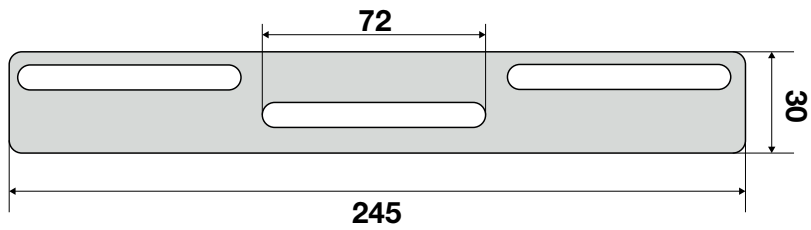
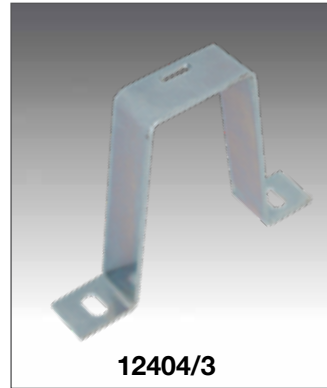
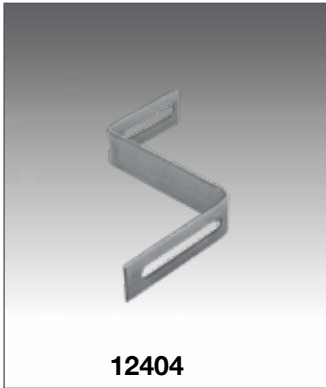

12404/2

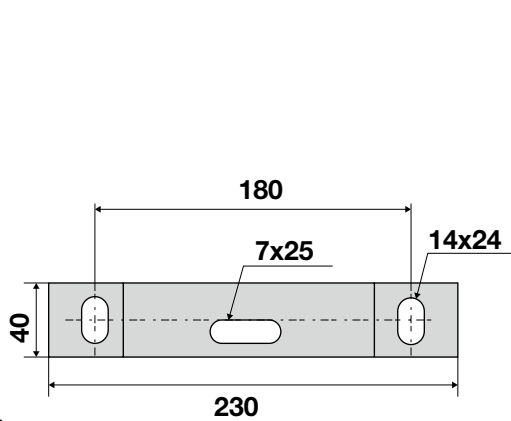

12404/3

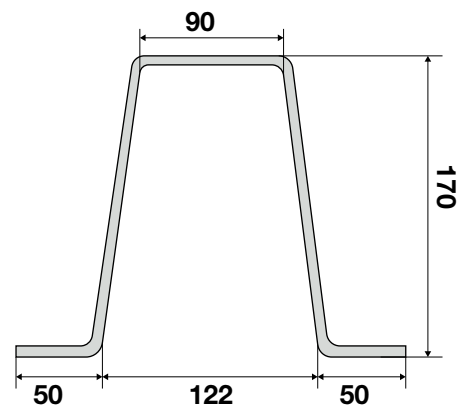

Codice / Code	Descrizione
12404	Staffa a "Z" per oliatore cod.12403/1
12404/2	Staffa piatta per oliatore cod.12403/1
12404/3	Staffa per oliatore a botticella tipo FIAM cod.12403

OLIO E GRASSO OILERS AND GREASE



15000A



15000B



15000C



15000D



15000E



15000F



15000G

Codice / Code	Descrizione
15000A	Pistola a stelo per cartucce lubroguide
15000B	Olio argani MEP 220 in latta da 20 litri
15000C	Olio idraulico per centraline HVI46 in latta da 20 litri
15000D	Grasso per bronzine e cuscinetti PVL3 in lattina da 4,5 kg.
15000E	Grasso spray multiuso in lattina TP1 400 ml
15000F	Olio per guide tipo ROTO EP320 in latta da 20 litri
15000G	Olio idraulico per centraline HVI68 in latta da 20 litri

**PUNTONE MOBILE DS - BRIDE PER GUIDE - CAPI FUNI E TIRANTI - MORSETTI A CAVALLOTTO E REDANCE
- FUNI ACCIAIO**

**PORTABLE STRUT DS - GUIDE RAIL CLIP - FLAT ROPE ANCHORAGE AND TENSION ROD - WIRE ROPE
CLIP AND CABLE THIMBLE - STEEL ROPE**

Bride per guide <i>Guide for rail clip</i>	16.3
Capifuni, tiranti, morsetti a cavallotto e redance <i>Flat rope anchorage, tension rod, wire rope clip and cable thimble</i>	16.4-16.5-16.6-16.7
Funi acciaio lucido preformate crociate certificate <i>Certified crossed polished steel rope</i>	16.8
Grembiule (paramento) <i>Toe-Guard</i>	16.9
Limitatori di velocità omologati con tenditori <i>Certified overspeed governors with tension</i>	16.10
Limitatori di velocità omologati <i>Certified overspeed governors</i>	16.11-16.12-16.13
Molla + distanziale + rondella <i>Spring + spacer + washer</i>	16.6
Puntone mobile DS <i>Portable Strut DS</i>	16.2
Tenditori a peso per limitatore con contatto <i>Tension Weight for overspeed governor with contact</i>	16.14

Note: I componenti sul catalogo con riportata una specifica marca di ascensore sono utilizzati abitualmente solo da questa marca. I particolari senza marca sono utilizzati da più marche di ascensori.

Note: The components in the catalogue with a specific lift brand are usually used only by the brand. Unbranded parts are used by multiple lift brands.

PUNTONE MOBILE DS PORTABLE STRUT DS

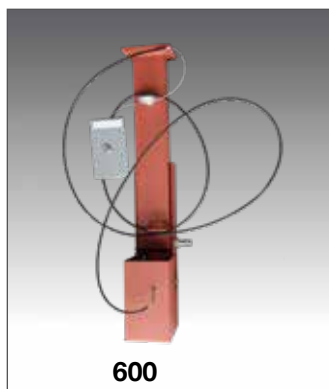

Puntone mobile DS è completo di scatola azionamento con serratura, 3 mt di cavo, morsetti e guaina.

Questo puntone è già stato installato e collaudato da vari ingegneri delle U.S.S.L. di Milano, Genova, Torino, Bologna, Palermo, etc.

Si garantisce la perfetta conformità al D.P.R 9/12/1987 N°587 Par. 2.3.

- Portata oltre 25000 N (2500 kg) calcolata al carico di punta coefficiente di sicurezza maggiore di 6.
- Il puntone è fornito con contatto IP31, su richiesta viene fornito anche in versione stagna IP65.
- Il carico non grava sul perno di rotazione ma direttamente sulla putrella a terra.
- Corredato da relazione di calcolo statico

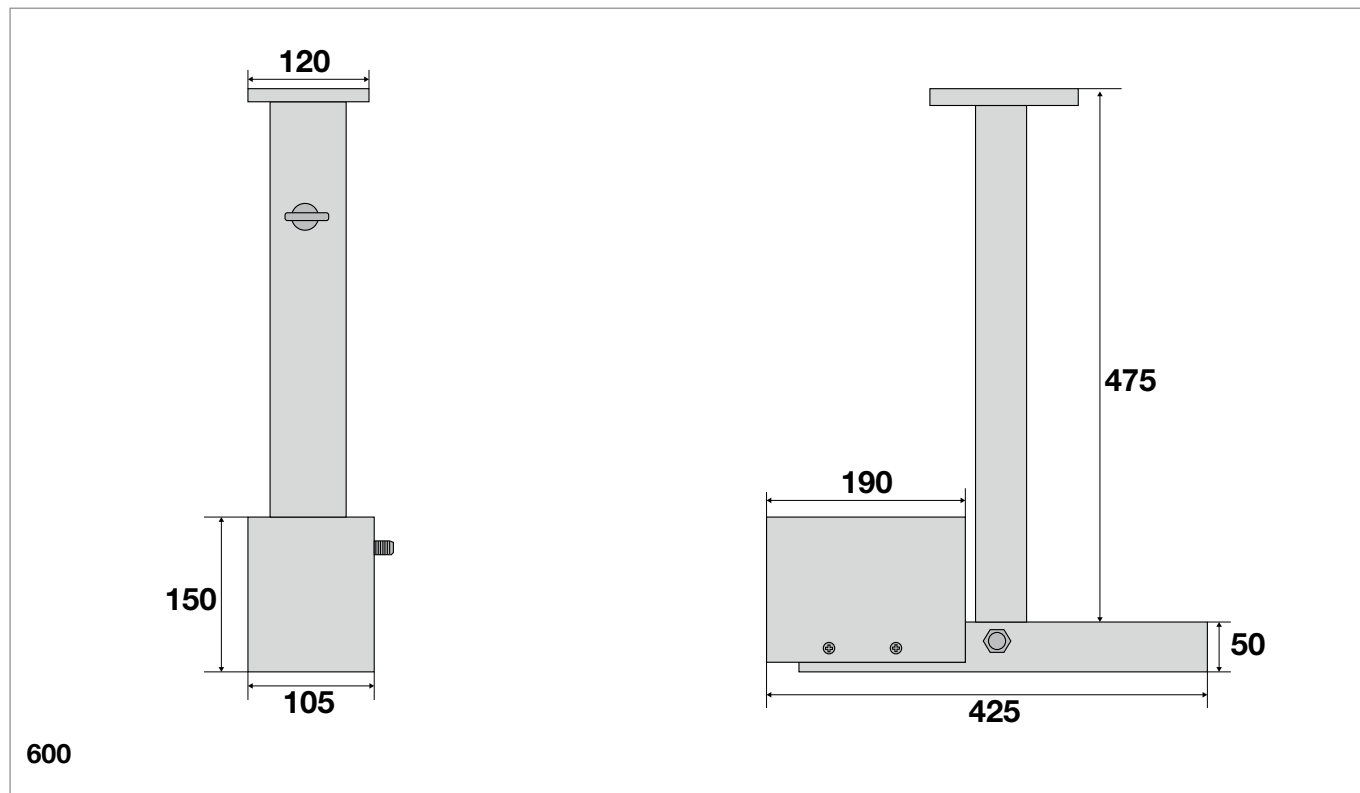

Codice / Code	Descrizione
600	Puntone mobile

**BRIDE PER GUIDE
GUIDE RAIL CLIP**

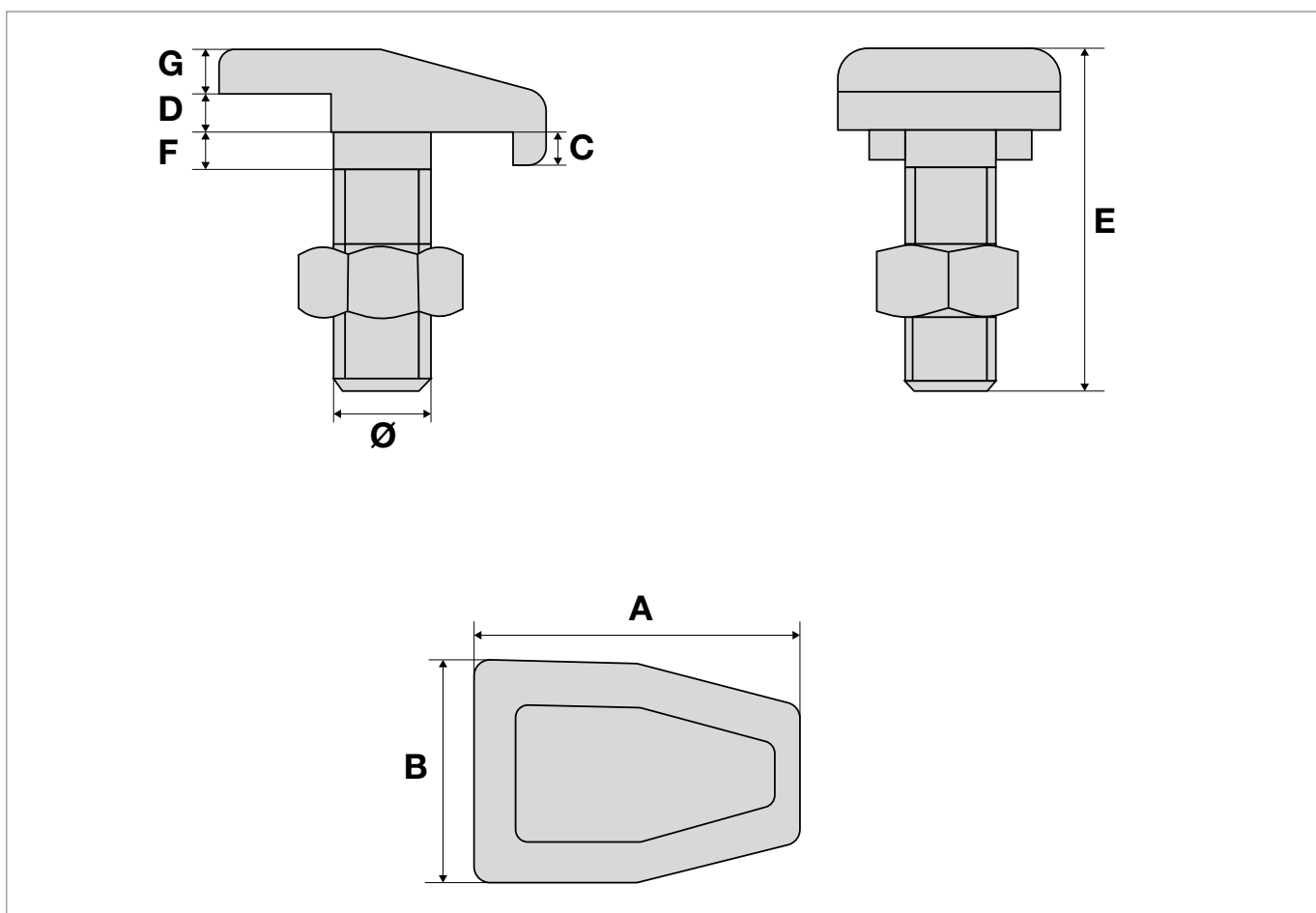

Codice / Code	Ø	A	B	C	D	E	F	G
BM10	M10	33	23	3	3	38	4,5	6
BM12	M12	40	38	3,5	4	44	7	7
BM14	M14	46	34	3,5	5	52	8	8
BM16	M16	53	37	5	7	57	6	7

CAPIFUNI FLAT ROPE ANCHORAGE

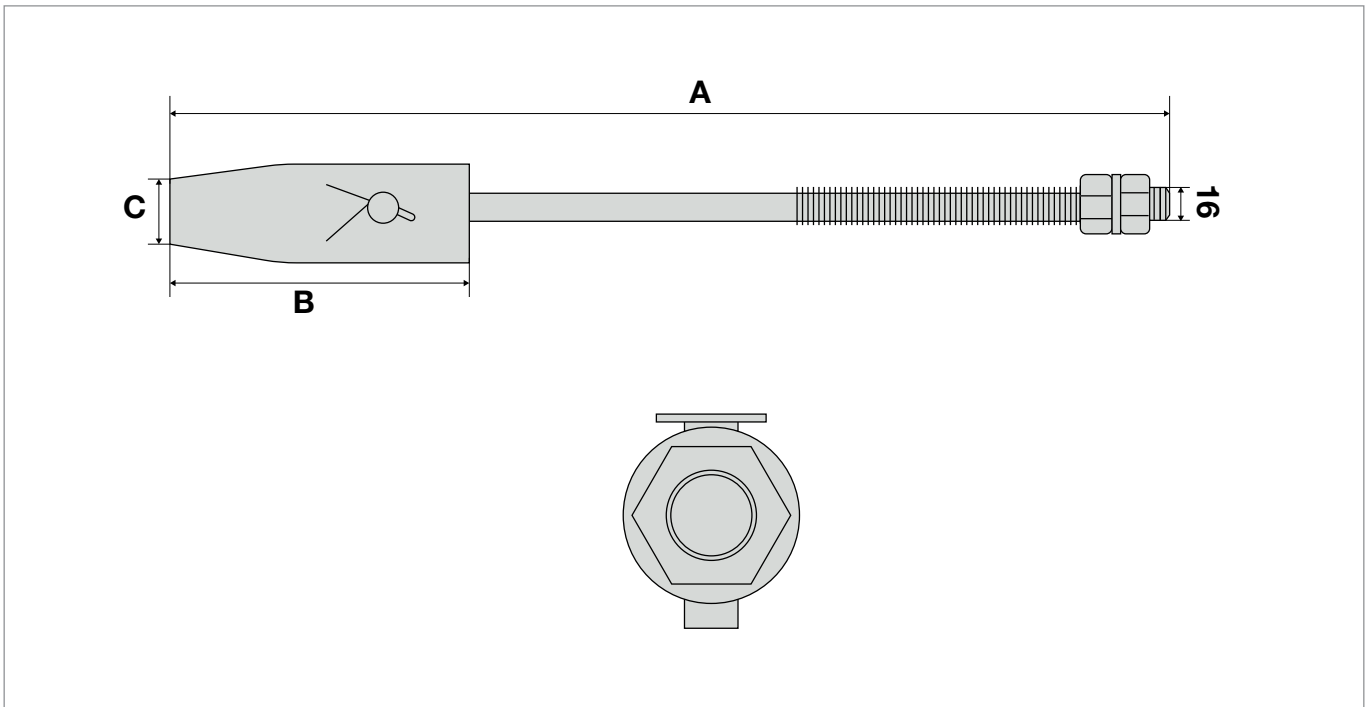

Codice / Code	Descrizione	A	B	C
482LT	Capofune tondo a cuneo Ø 9 - 10 senza molla	460	130	34
4821LT	Capofune tondo a cuneo Ø 11 senza molla	460	130	34
483LT	Capofune tondo a cuneo Ø 11 con molla	460	135	34
483LT1	Capofune tondo a cuneo Ø 12 con molla	460	135	34
4831LT	Capofune tondo a cuneo Ø 12 senza molla	460	135	34

CAPIFUNI FLAT ROPE ANCHORAGE

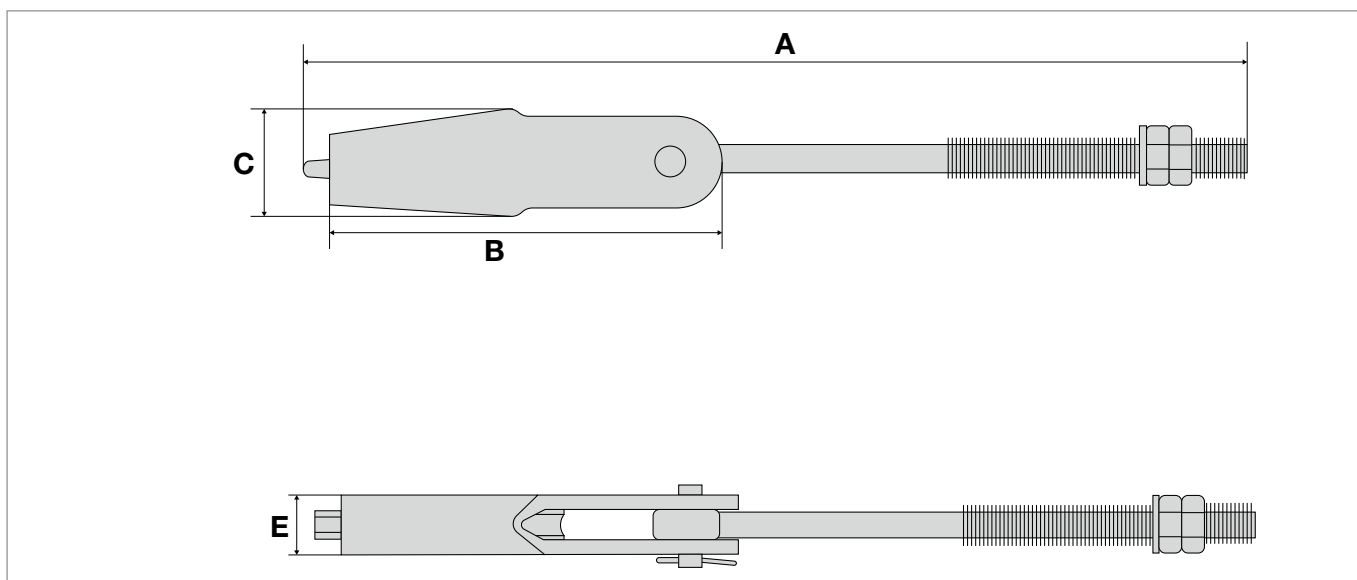
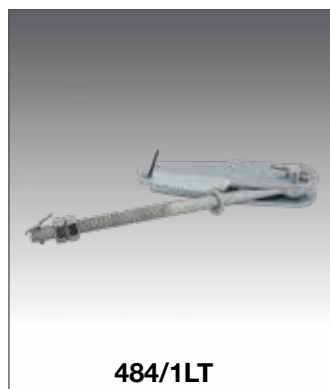
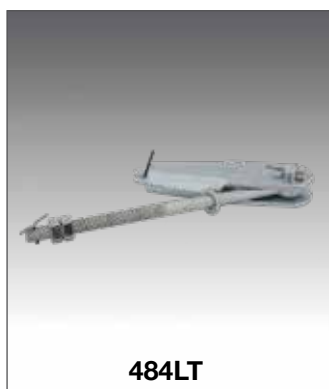

Codice / Code	A	B	C	D	E	Fune Ø
484LT	520	185	60	M16	30	9 - 11
484/1LT	615	190	60	M16	30	9 - 11
484/2LT	465	150	45	M12	20	6 - 8
485LT	542	230	77	M20	36	12 - 14

Codice / Code	Descrizione
484LT	Capofune piatto a cuneo Ø 9 - 11 barra L.300 mm senza molla
484/1LT	Capofune piatto a cuneo Ø 9 - 11 barra L.400 mm senza molla
484/2LT	Capofune piatto a cuneo Ø 6 - 8 senza molla
485LT	Capofune piatto a cuneo Ø 12 - 14 senza molla

TIRANTI TENSION ROD

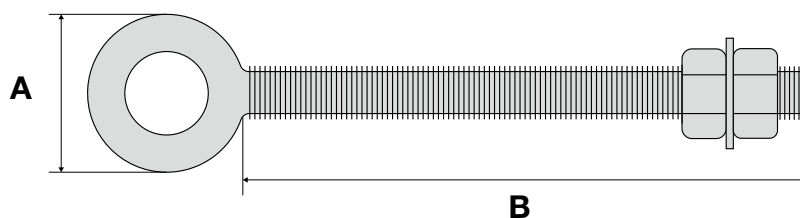
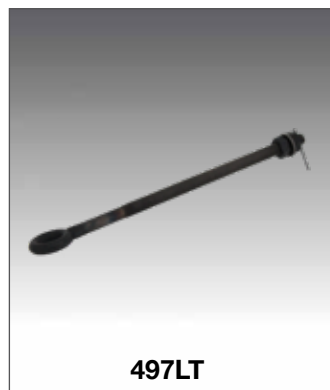

Codice / Code	Descrizione	A	B
494LT	Tirante ad occhio L.150mm M12 senza molla	Ø 38 mm	131 mm
495LT	Tirante ad occhio L.270mm M12 senza molla	Ø 45 mm	380 mm
496LT	Tirante ad occhio L.300mm M16 senza molla	Ø 45 mm	280 mm
497LT	Tirante ad occhio L.400mm M16 senza molla	Ø 38 mm	270 mm

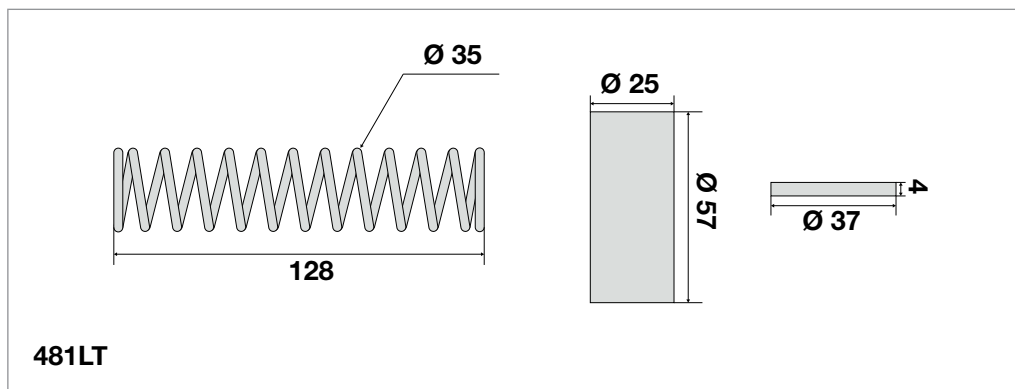

Codice / Code	Descrizione
481LT	Molla + distanziale + rondella

REDANCE - MORSETTI A CAVALLOTTO CABLE THIMBLE - WIRE ROPE CLIP



Morsetto a cavallotto



Morsetto a cavallotto

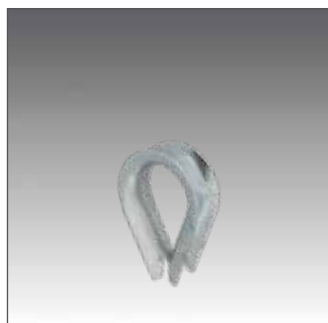

Redance



Redance

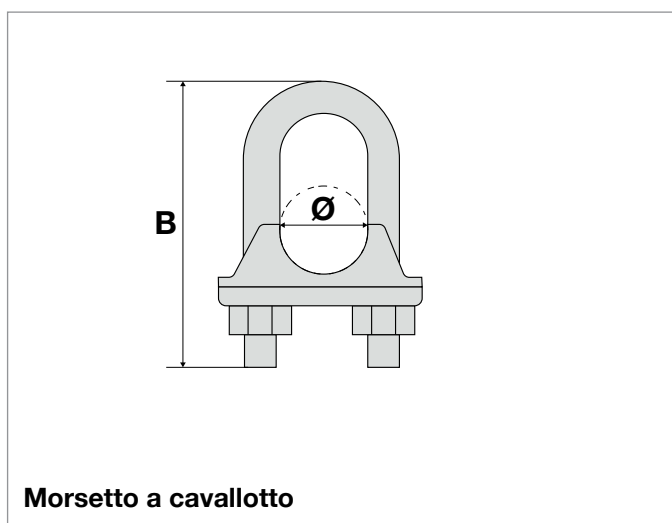

Morsetto a cavallotto

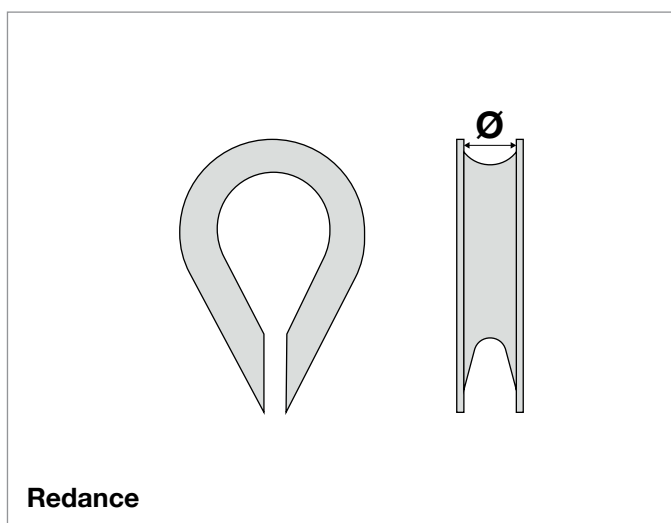

Redance

Codice / Code	Descrizione	Ø	Forza KN
488LT	Redance	5 - 6	100
489LT	Redance	7 - 8	50
490LT	Redance	9 - 10	44
491LT	Redance	11 - 12	64
492LT	Redance	13 - 14	74

Codice / Code	Descrizione	Ø	B
4859LT	Morsetto a cavallotto	3 - 4	20 mm
4871LT	Morsetto a cavallotto	5 - 6	29 mm
4862LT	Morsetto a cavallotto	7 - 8	36 mm
4860LT	Morsetto a cavallotto	9 - 10	43 mm
4861LT	Morsetto a cavallotto	11	44 mm
486LT	Morsetto a cavallotto	12 - 13	55 mm

FUNI IN ACCIAIO CROCIATE CERTIFICATE CERTIFIED CROSSED POLISHED STEEL ROPE

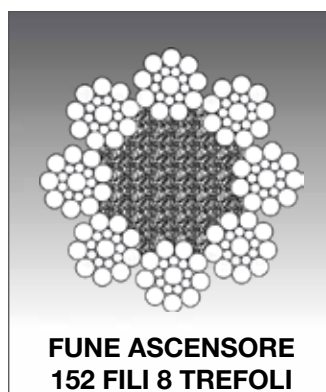
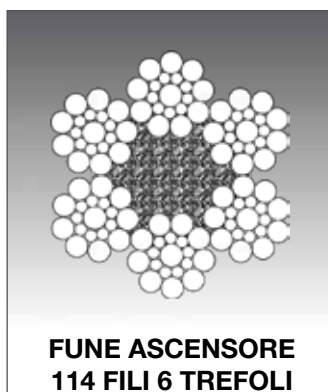
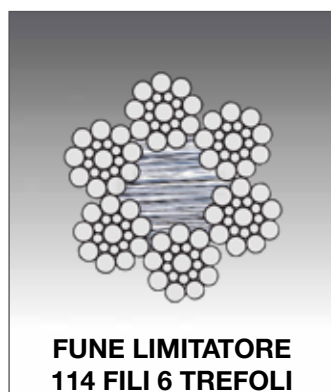

FUNE PER LIMITATORE 114 FILI 6 TREFOLI

Codice	Descrizione
FL114F6DX	Fune per limitatore 114 F. 6T + Seale Diam. 6 DX
FL114F7DX	Fune per limitatore 114 F. 6T + Seale Diam. 7 DX

FUNE PER ASCENSORE 114 FILI 6 TREFOLI

Codice	Descrizione
FT114F08DX	Fune Trazione 114 F. 6T + Seale Diam. 8 DX
FT114F08SX	Fune Trazione 114 F. 6T + Seale Diam. 8 SX
FT114F09DX	Fune Trazione 114 F. 6T + Seale Diam. 9 DX
FT114F09SX	Fune Trazione 114 F. 6T + Seale Diam. 9 SX
FT114F10DX	Fune Trazione 114 F. 6T + Seale Diam.10 DX
FT114F10SX	Fune Trazione 114 F. 6T + Seale Diam.10 SX
FT114F11DX	Fune Trazione 114 F. 6T + Seale Diam.11 DX
FT114F11SX	Fune Trazione 114 F. 6T + Seale Diam.11 SX
FT114F12DX	Fune Trazione 114 F. 6T + Seale Diam.12 DX
FT114F12SX	Fune Trazione 114 F. 6T + Seale Diam.12 SX
FT114F13DX	Fune Trazione 114 F. 6T + Seale Diam.13 DX
FT114F13SX	Fune Trazione 114 F. 6T + Seale Diam.13 SX

FUNE PER ASCENSORE 152 FILI 8 TREFOLI

Codice	Descrizione
FT152F08DX	Fune Trazione 152 F. 8T + Seale Diam. 8 DX
FT152F08SX	Fune Trazione 152 F. 8T + Seale Diam. 8 SX
FT152F09DX	Fune Trazione 152 F. 8T + Seale Diam. 9 DX
FT152F09SX	Fune Trazione 152 F. 8T + Seale Diam. 9 SX
FT152F10DX	Fune Trazione 152 F. 8T + Seale Diam.10 DX
FT152F10SX	Fune Trazione 152 F. 8T + Seale Diam.10 SX
FT152F11DX	Fune Trazione 152 F. 8T + Seale Diam.11 DX
FT152F11SX	Fune Trazione 152 F. 8T + Seale Diam.11 SX
FT152F12DX	Fune Trazione 152 F. 8T + Seale Diam.12 DX
FT152F12SX	Fune Trazione 152 F. 8T + Seale Diam.12 SX
FT152F13DX	Fune Trazione 152 F. 8T + Seale Diam.13 DX
FT152F13SX	Fune Trazione 152 F. 8T + Seale Diam.13 SX
FT152F14DX	Fune Trazione 152 F. 8T + Seale Diam.14 DX
FT152F14SX	Fune Trazione 152 F. 8T + Seale Diam.14 SX
FT152F15DX	Fune Trazione 152 F. 8T + Seale Diam.15 DX
FT152F15SX	Fune Trazione 152 F. 8T + Seale Diam.15 SX
FT152F16DX	Fune Trazione 152 F. 8T + Seale Diam.16 DX
FT152F16SX	Fune Trazione 152 F. 8T + Seale Diam.16 SX

**A richiesta funi trattate anticorrosione
per ascensori da esterno soggetto
parzialmente ad agenti atmosferici**

GREMBIULE (PARAMENTO) TOE-GUARD (METAL SHEET)

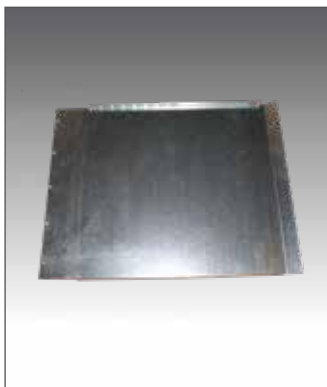

Ogni soglia di cabina, deve essere munita di un paramento che si estenda per tutta la larghezza di accesso delle porte di piano servite.

Comunicare la larghezza (luce netta della porta).
Il paramento sarà dotato di staffe di montaggio e sarà più largo della porta.

M1: modulo
NF: numero di fori
A: distanza dal bordo del grembiule al primo foro
M2: modulo 2 ovvero il grembiule è formato da 2 moduli di lamiera

Luce porte	M1	A	NF	M2
500/600	650	75	5	—
500/600	625	62,5	5	—
650	700	100	5	—
700	750	62,5	6	—
750	800	25	7	—
800/850	875	62,5	7	—
800/850	900	75	7	—
900/950	1000	62,5	8	—
1000/1100	1125	62,5	9	—
1150/1350	1375	62,5	11	—
1400/1450	1500	—	12	750
1500/1700	1750	—	14	875
1750/1950	2000	—	16	1000
2000/2200	2250	—	18	1125
2250/2700	2750	—	22	1375

CODICE DI ORDINAZIONE

Paramenti per impianti a fune			
PIF600	Paramento L 600	PIF800	Paramento L 800
PIF650	Paramento L 650	PIF850	Paramento L 850
PIF700	Paramento L 700	PIF900	Paramento L 900
PIF750	Paramento L 750	PIF1000	Paramento L 1000

Paramenti per impianti oleodinamici			
PIO600	Paramento L 600	PIO800	Paramento L 800
PIO650	Paramento L 650	PIO850	Paramento L 850
PIO700	Paramento L 700	PIO900	Paramento L 900
PIO750	Paramento L 750	PIO1000	Paramento L 1000

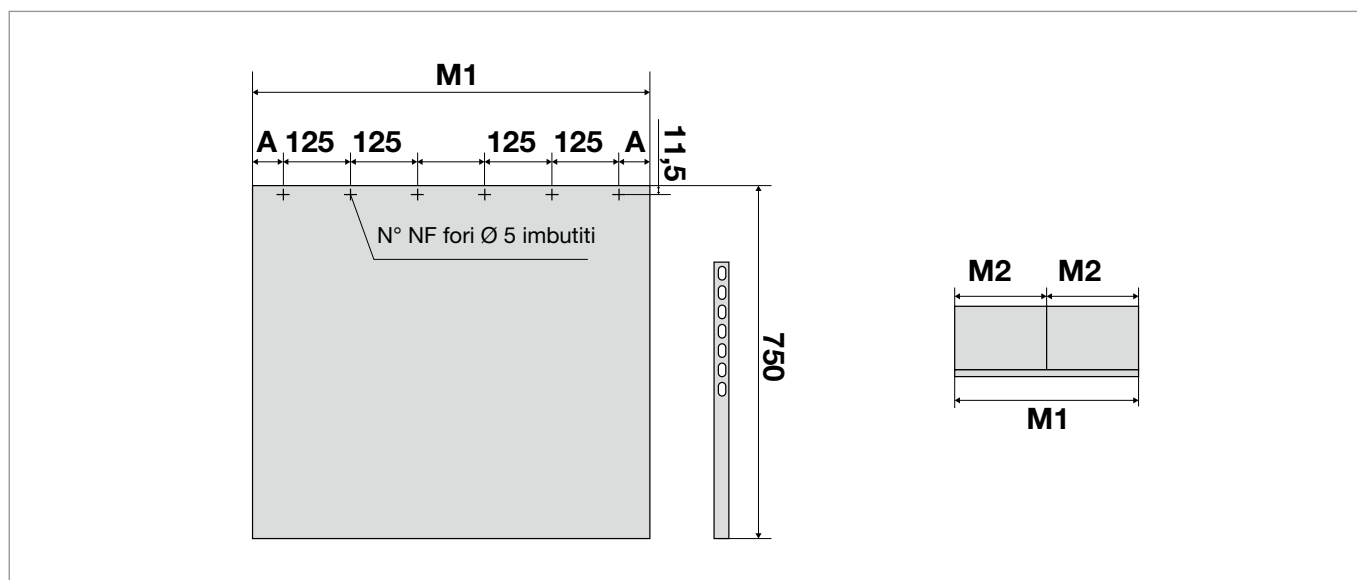

LIMITATORI DI VELOCITÀ OMOLOGATI CON TENDITORE CERTIFIED OVERSPEED GOVERNORS WITH TENSION

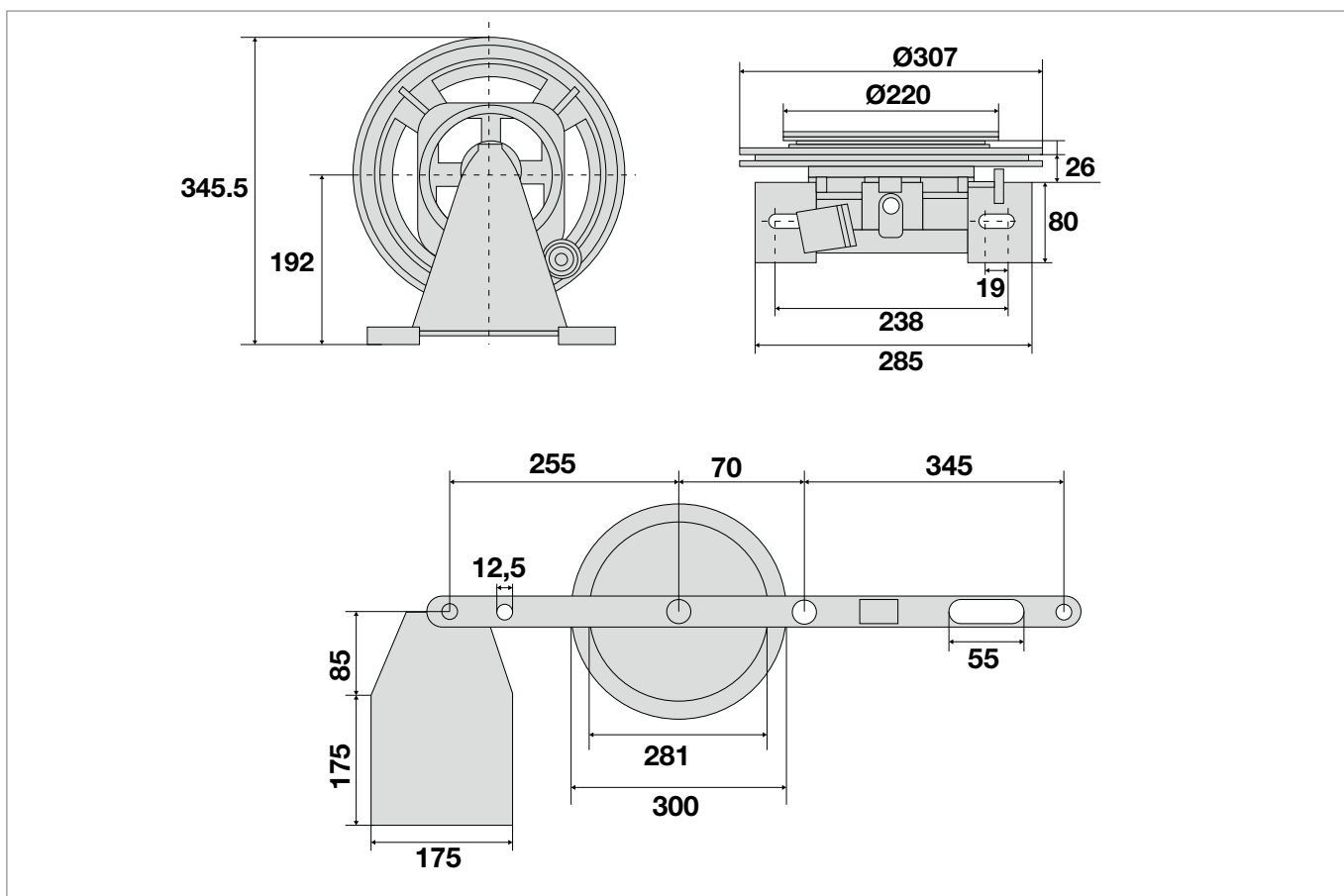

Limitatore di velocità bidirezionale omologato

Puleggia Ø 300.

Certificato EN81-50:2014 5.4

EN81-50: 2014 5 - 6.2.2.1 - 5.6.2.2 - 5.6.6 in conformità requisiti su ascensore 2014/33/AB modulo B-IVA

Bidirectional overspeed governor

Pulley Ø 300.

According to EN81-50:2014 5.4

EN81-50: 2014 5 - 6.2.2.1 - 5.6.2.2 - 5.6.6 in compliance with the requirement for lift 2014/33/AB form B-IVA

Codice / Code	Descrizione
542/1B1SET	Limitatore di velocità R1 300 bidirezionale VI=0,82 con tenditore
542/1B2SET	Limitatore di velocità R1 300 bidirezionale VI=0,92 con tenditore
542/1B3SET	Limitatore di velocità R1 300 bidirezionale VI=1,00 con tenditore

LIMITATORI DI VELOCITÀ OMOLOGATI CERTIFIED OVERSPEED GOVERNORS



Limitatore Bidirezionale omologato

Puleggia Ø 300. Omologato TÜV. A norma 95/16/CE ed EN81. Velocità nominale fino a 1,74 m/s a Velocità d'intervento da 0,40 m/s fino a 2,00 m/s. Fornibile con carter di protezione, gola indurita e sistema anticarrucolamento.

Bidirectional governors

Pulley Ø 300. Certified TÜV, to norms 95/16/EC and EN 81. Nominal speed up to 1,74 m/s. Intervention speed from 0,40 m/s to 2,00 m/s. Supplied with chain guard of protection, hardened throat and anti-derailment system.

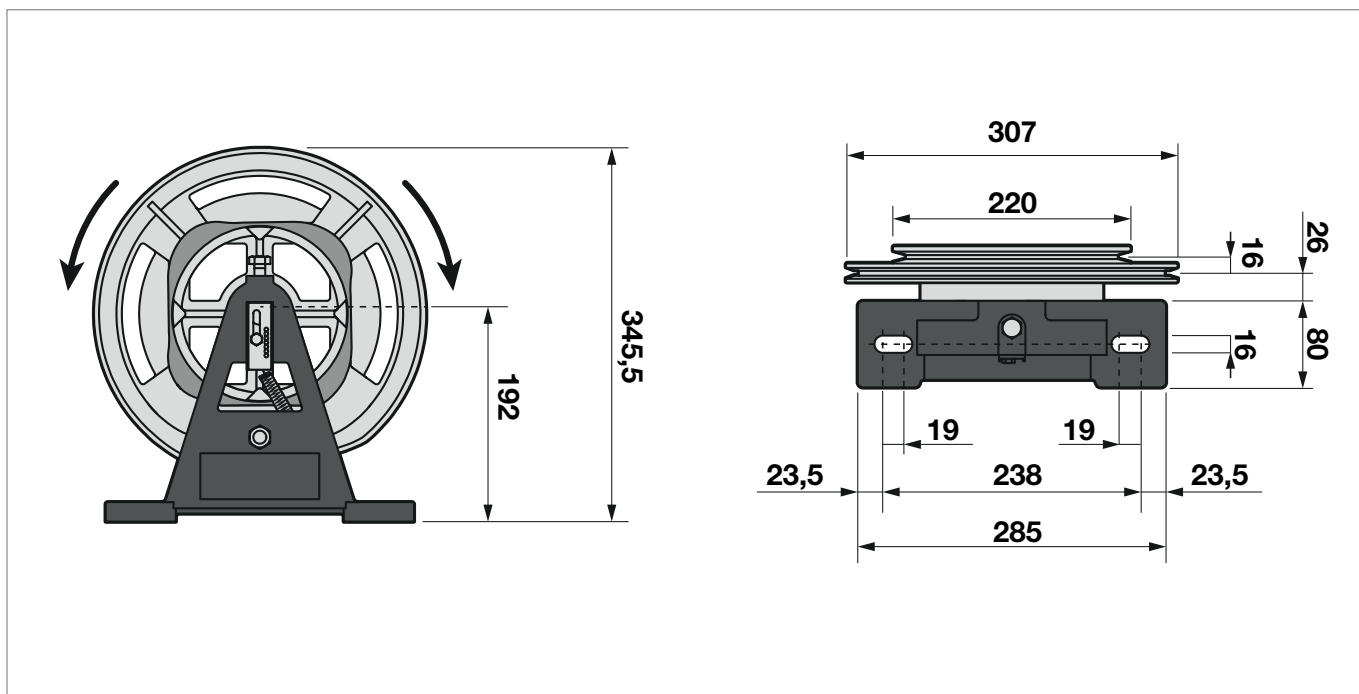

Codice / Code	Descrizione
542/1B1	Limitatore di velocità R1 300 bidirezionale VI=0,82
542/1B2	Limitatore di velocità R1 300 bidirezionale VI=0,92
542/1B3	Limitatore di velocità R1 300 bidirezionale VI=1,00
542/1B4	Limitatore di velocità R1 300 bidirezionale VI=1,25
542/1B5	Limitatore di velocità R1 300 bidirezionale VI=1,15

Codice / Code	Descrizione
542/1B6	Limitatore di velocità R1 200 bidirezionale VI=0,92

Codice / Code	Descrizione
542/1B7	Limitatore di velocità R1 250 bidirezionale VI=0,92
542/1B8	Limitatore di velocità R1 250 bidirezionale VI=1,00

LIMITATORI DI VELOCITÀ OMOLOGATI CERTIFIED OVERSPEED GOVERNORS



540 - 540/1 - 540/1A



542/1DX - 542/1SX

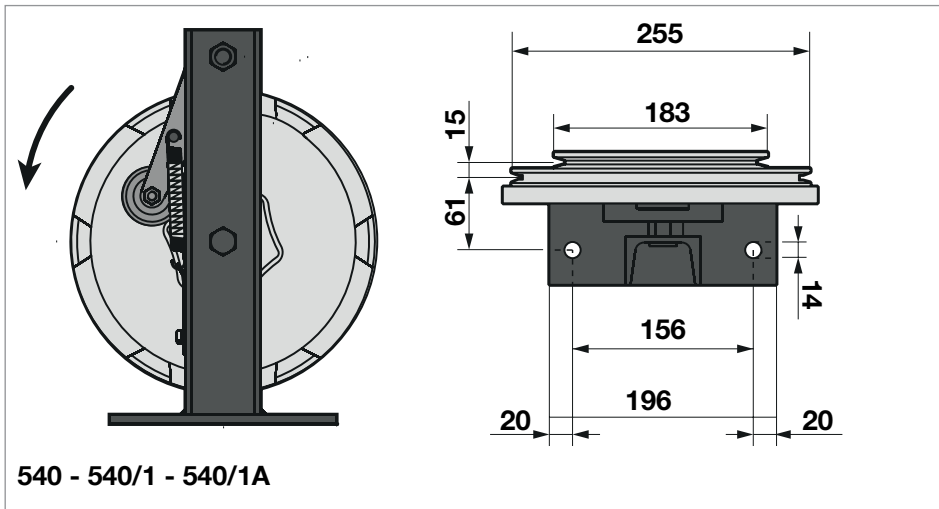

540 - 540/1 - 540/1A

Limitatore intercambiabile FIAM
Puleggia Ø 260. Fornibile anche con carter di protezione. Omologato TÜV secondo le norme 95/16/CE ed EN81. Velocità di intervento da 0,48 a 1,43 m. Fornibile anche con gola indurita.

Interchange governors FIAM
Pulley Ø 260. Certified TÜV, to norms 95/16/EC and EN 81. Nominal speed up to 1,24 m/s. Intervention speed from 0,48 m/s to 1,43 m/s. Supplied with hardened throat.

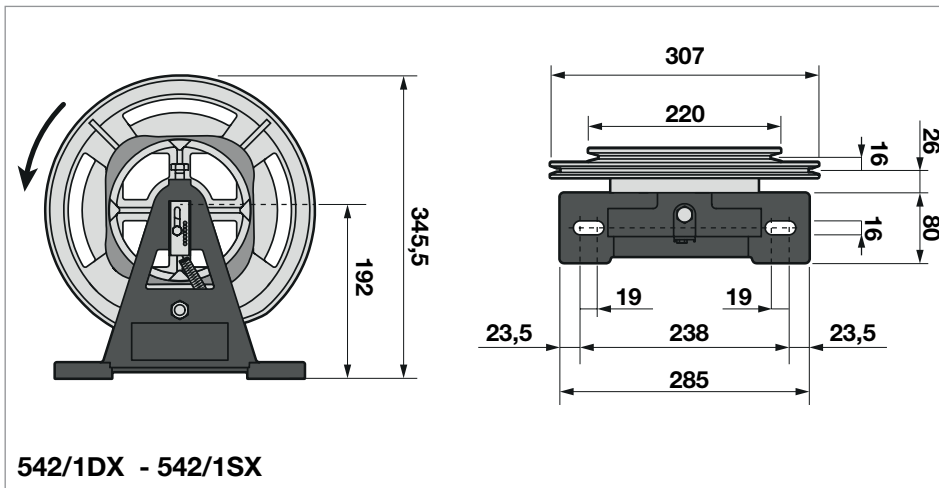

542/1DX - 542/1SX

Limitatore monodirezionale omologato
Puleggia Ø 300. Omologato TÜV. A norma 95/16/CE ed EN81.

Monodirectional governors
Pulley Ø 300. Certified TÜV, to norms 95/16/EC and EN 81.

Attenzione i limitatori di velocità monodirezionali sotto riportati sono disponibili fino ad esaurimento scorta di magazzino.

Codice / Code	Descrizione
540	Limitatore di velocità R3 D.260 EN81 FIAM DX VI=1,00
540/1	Limitatore di velocità R3 D.260 EN81 FIAM DX VI=0,82
540/1A	Limitatore di velocità R3 D.260 EN81 FIAM DX VI=0,92

Codice / Code	Descrizione
542/1DX	Limitatore di velocità R1 300 DX
542/1SX	Limitatore di velocità R1 300 SX

LIMITATORI DI VELOCITÀ OMOLOGATI HOMOLOGATED OVERSPEED GOVERNORS



540/2 - 540/3

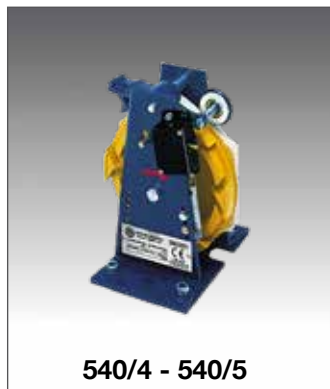

540/4 - 540/5

Limitatore completamente montato su cuscinetti omologato

Puleggia Ø 200. Omologato TÜV secondo le norme 95/16/CE ed EN81. Velocità nominale fino a 1,55 m/s. Velocità di intervento da 0,24 a 1,78 m/s. Fornibile anche con: basamento ad ingombro ridotto a salva fune, gola indurita, comando a distanza.

Certified governors completely mounted on bearings
Pulley Ø 200. Certified TÜV, according to 95/16/EC and EN 81. Nominal speed up to 1,55 m/s. Intervention speed from 0,24 up to 1,78. Supplied with: space-saving base for rope protection, hardened throat, remote control.

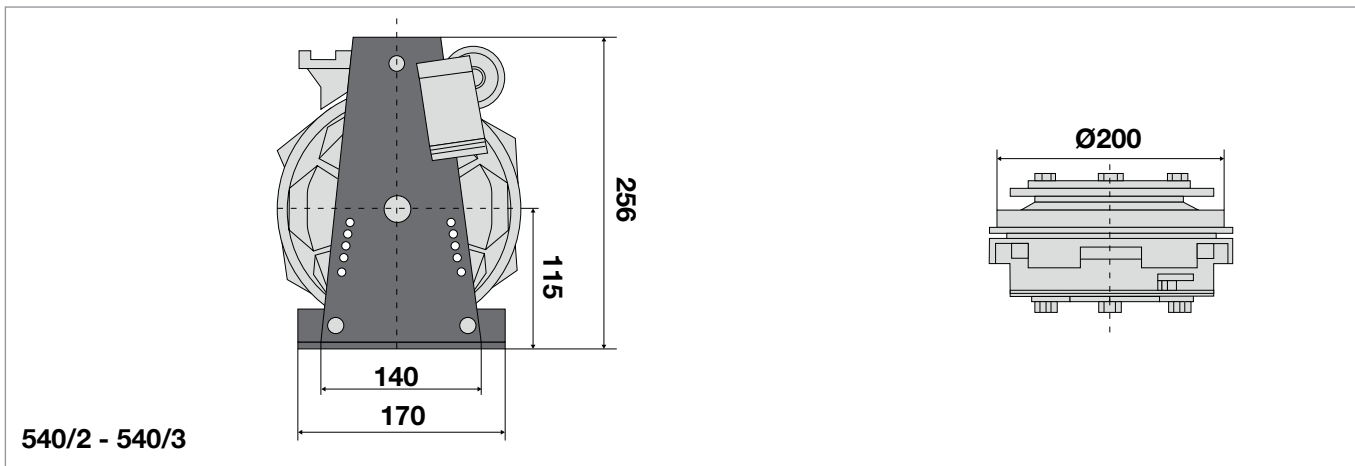

540/2 - 540/3

Limitatore completamente montato su cuscinetti omologato

Puleggia Ø 300. Omologato TÜV secondo le norme 95/16/CE ed EN81. Velocità nominale fino a 2,09 m/s. Velocità di intervento da 0,44 a 2,40 m/s. Fornibile anche con: basamento ad ingombro ridotto a salva fune, gola indurita, comando a distanza.

Certified governors completely mounted on bearings

Pulley Ø 300. Certified TÜV, according to 95/16/EC and EN 81. Nominal speed up to 2,09 m/s. Intervention speed from 0,44 up to 2,40. Supplied with: space-saving base for rope protection, hardened throat, remote control.

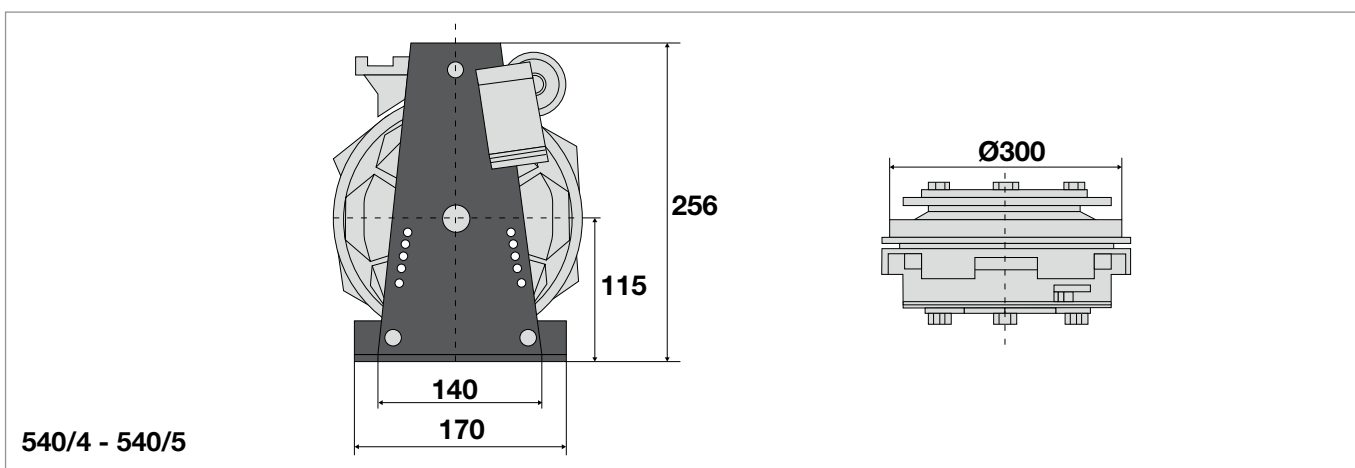

540/4 - 540/5

Codice / Code	
540/2	Limitatore di velocità DX VI=0 - 1,46 m/sec
540/3	Limitatore di velocità SX VI=0 - 1,68 m/sec
540/4	Limitatore di velocità SB DX VI=0 - 1,82 m/s
540/5	Limitatore di velocità SB SX VI=0 - 2,1 m/s

TENDITORE A PESO PER LIMITATORE CON CONTATTO OMOLOGATI CERTIFIED TENSION WEIGHT FOR OVERSPEED GOVERNOR WITH CONTACT



543 - 543/1 - 543/2



543/1V

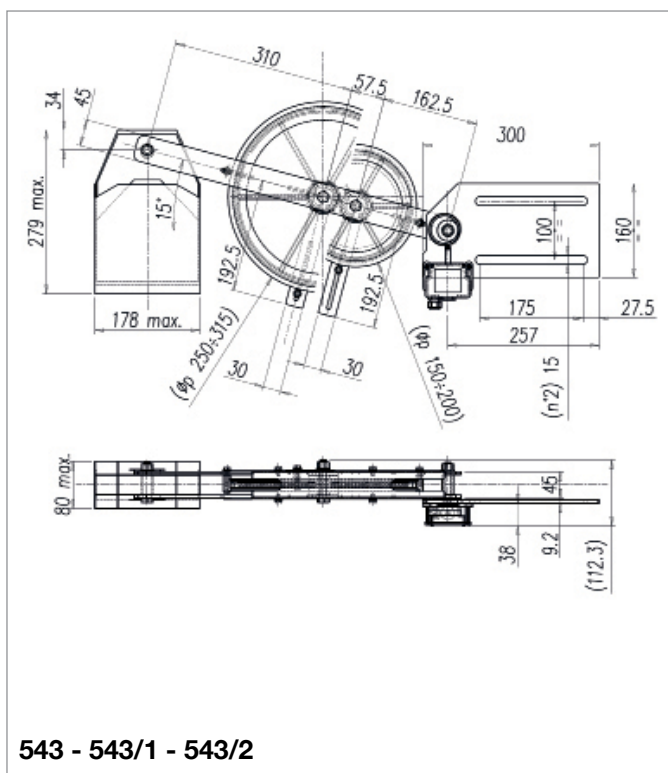

543 - 543/1 - 543/2

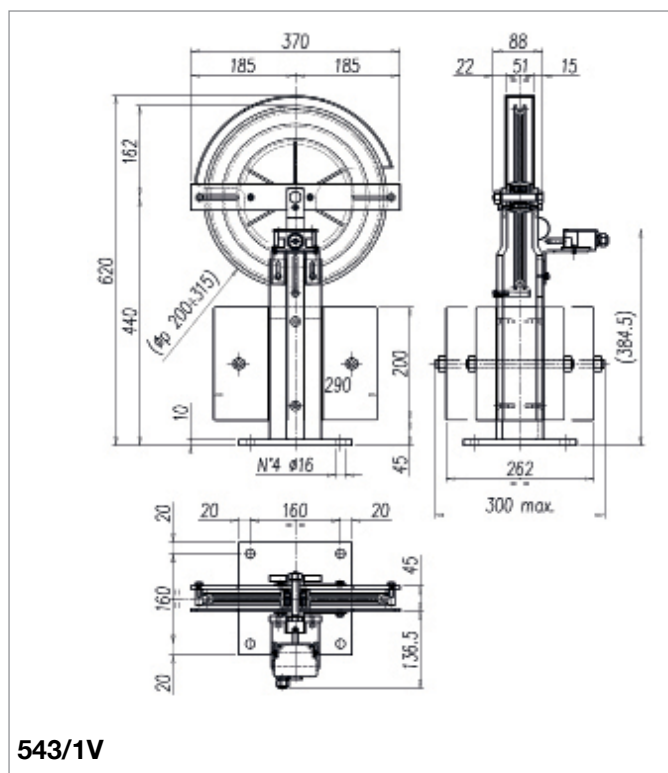

543/1V

Tenditori R4 Ø 200 - Ø 260 - Ø 300.

Completo di contrappeso in ghisa (30-60-104 kg) fornibili a richiesta: contatto di sicurezza, sistema antiscarrucolamento e carter di protezione.

Tension weight type R4 Ø 200 - Ø 300 and Ø 315 with complete cast iron counterweight (30-60-104 kg). supplied on demands with: safety switch, anti-derailment system and cover of protection .

Codice / Code	Descrizione
543	Tenditore peso + contatto per limitatore puleggia DIAM. 260
543/1	Tenditore peso + contatto per limitatore puleggia DIAM. 300
543/1V	Tenditore peso + contatto per limitatore R4 verticale DIAM. 300 contrappeso 30 kg
543/2	Tenditore peso + contatto per limitatore puleggia DIAM. 200
543/1C	Contrappeso da 10 kg. per tenditore cod. 543/1

SPESSORI - PIASTRINE
SHIM FOR GUIDE RAILS - MOUNTING PLATE

Piastrine spessoramento guide cabina FIAM 17.2
Thickness mounting plate for guide cabin FIAM

Spessore in fibra motori argano 27 - 3N - 5N - 55 FIAM 17.2
Fibre shim For traction machine 27 - 3N - 5N - 55 FIAM

Note: I componenti sul catalogo con riportata una specifica marca di ascensore sono utilizzati abitualmente solo da questa marca. I particolari senza marca sono utilizzati da più marche di ascensori.

Note: *The components in the catalogue with a specific lift brand are usually used only by the brand. Unbranded parts are used by multiple lift brands.*

SPESSORI - PIASTRINE SHIM FOR GUIDE RAILS - MOUNTING PLATE

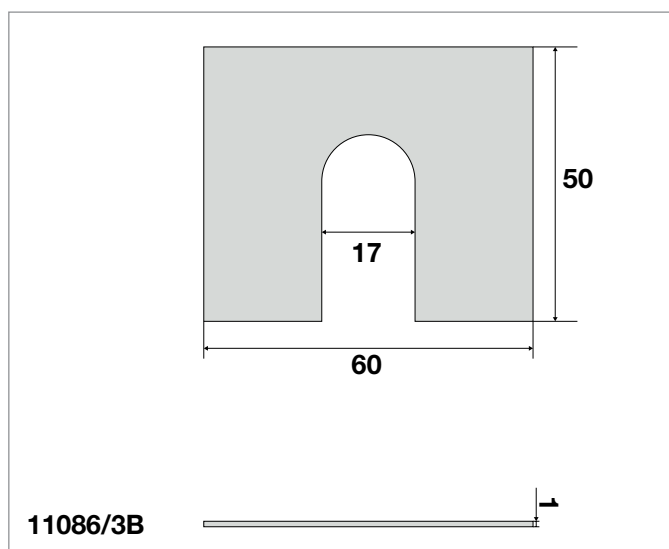
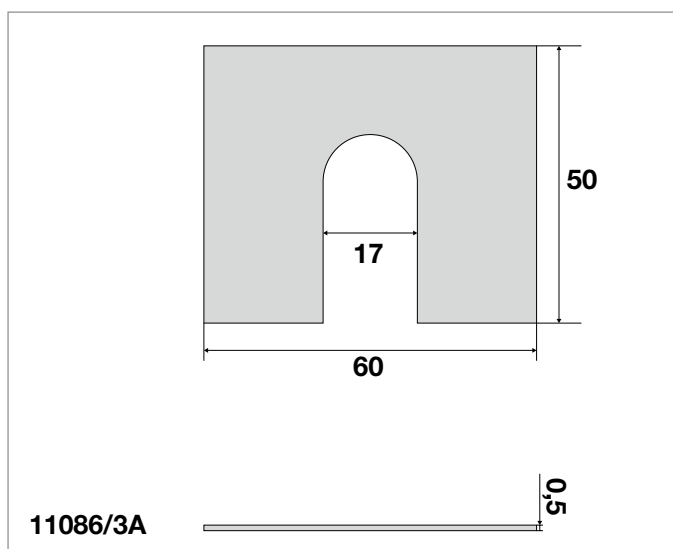
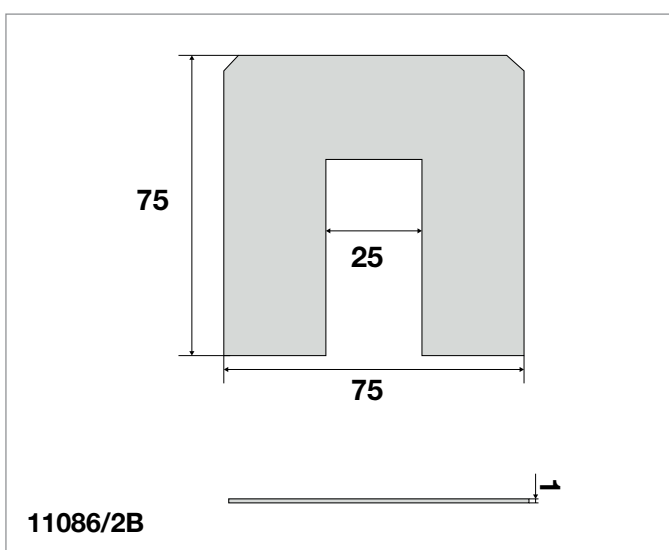
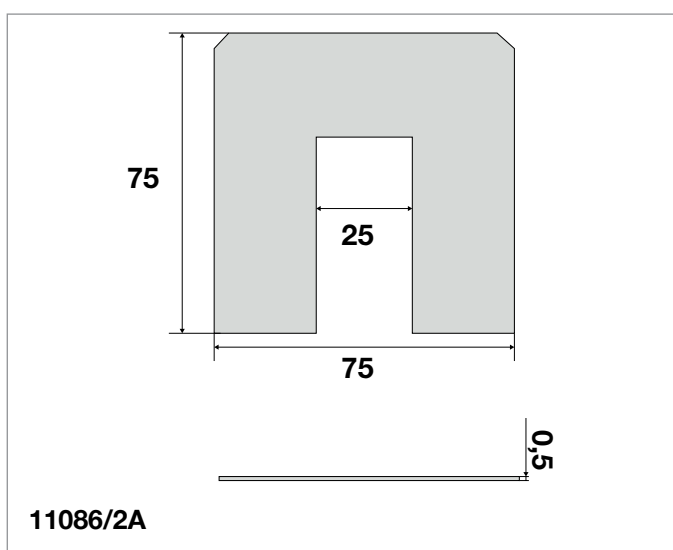
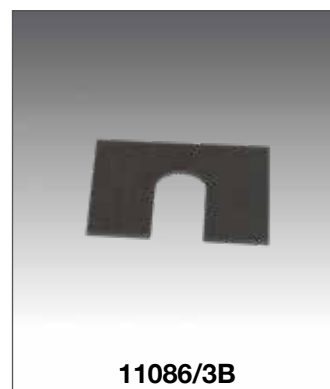
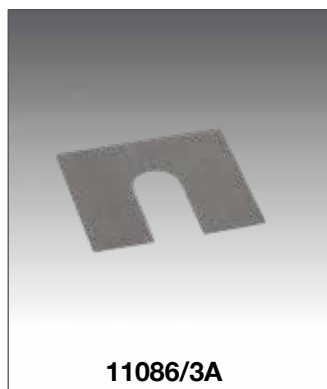

Codice / Code	Descrizione
11086/2A	Spessore in fibra per motori argano FIAM 27 - 3N - 5N - 55 dim. 75x75x0,5
11086/2B	Spessore in fibra per motori argano FIAM 27 - 3N - 5N - 55 dim. 75x75x1
11086/3A	Piastrine spessoramento guide cabina FIAM spessore 0,5 mm
11086/3B	Piastrine spessoramento guide cabina FIAM spessore 1 mm

SUPPORTI PATTINI (PORTA PATTINI) - PULEGGE DI TRAZIONE E RINVIO
GUIDE SHOE SUPPORT (GUIDE SHOE) - TRACTION SHEAVE

Pulegge di trazione e rinvio	18.4
<i>Traction and Tail Sheave</i>	
Supporto pattini portata 1000/2500/3500 kg	18.2
<i>Supports for guide shoes 1000/2500/3500 kg</i>	
Supporto pattino FALCONI - OTIS - STANDARD	18.3
<i>Support guide shoe FALCONI - OTIS - STANDARD</i>	

Note: I componenti sul catalogo con riportata una specifica marca di ascensore sono utilizzati abitualmente solo da questa marca. I particolari senza marca sono utilizzati da più marche di ascensori.

Note: *The components in the catalogue with a specific lift brand are usually used only by the brand. Unbranded parts are used by multiple lift brands.*

SUPPORTO PATTINI GUIDE SHOE SUPPORT

18

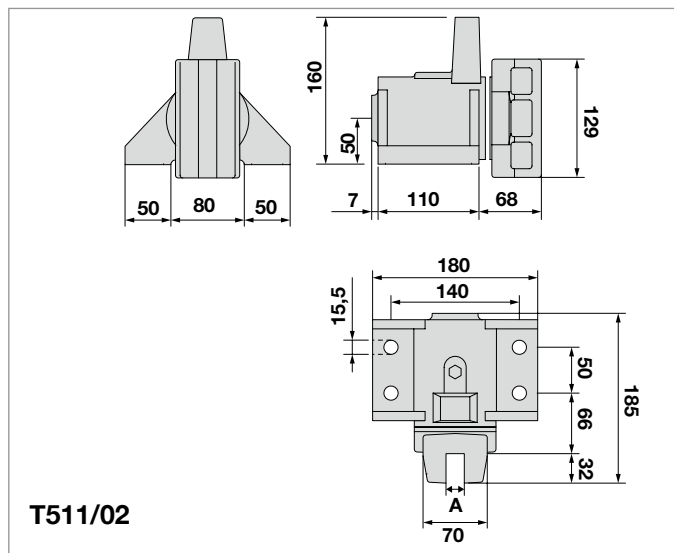
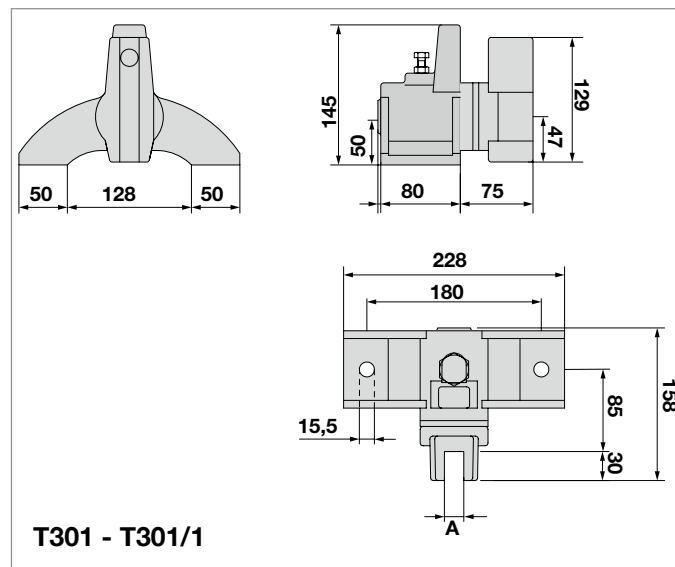
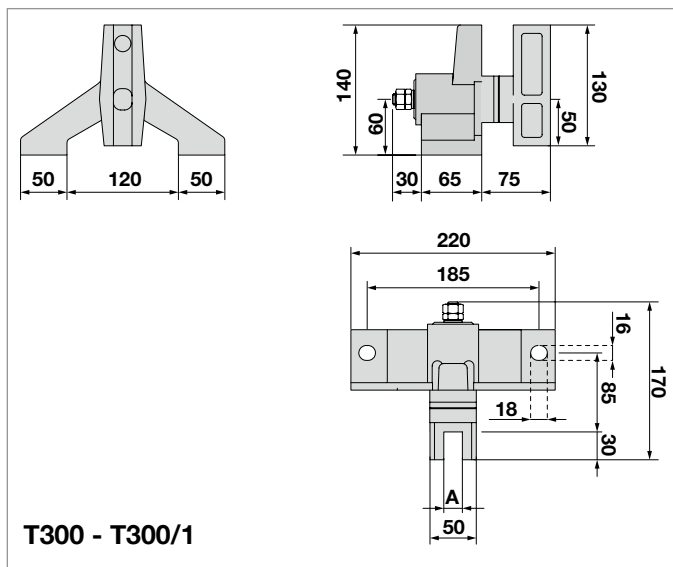

Codice / Code	Descrizione	A
T300	Supporto pattino in ghisa C 20 1000 Kg.	20
T300/1	Supporto pattino in ghisa C 24 1000 Kg.	24
T301	Supporto pattino in ghisa C 20 2500 Kg.	20
T301/1	Supporto pattino in ghisa C 24 2500 Kg.	24
T511/02	Supporto pattino in ghisa C 24 3500 Kg.	24

SUPPORTO PATTINI GUIDE SHOE SUPPORT

18

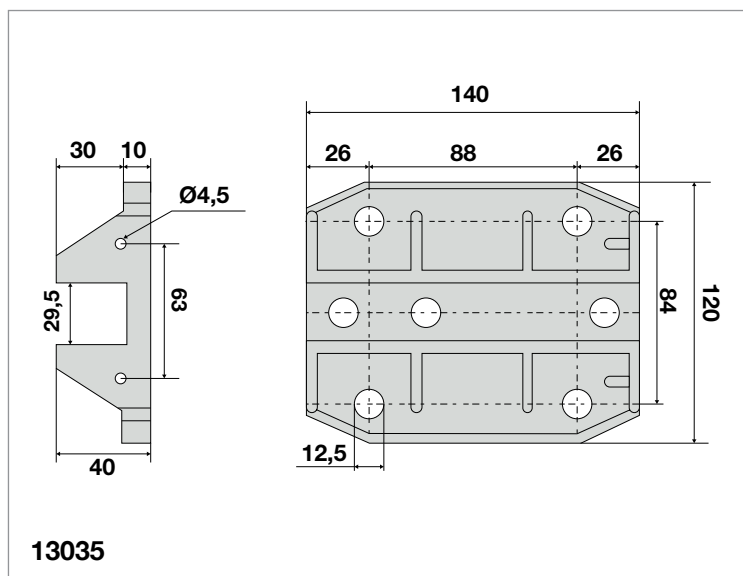
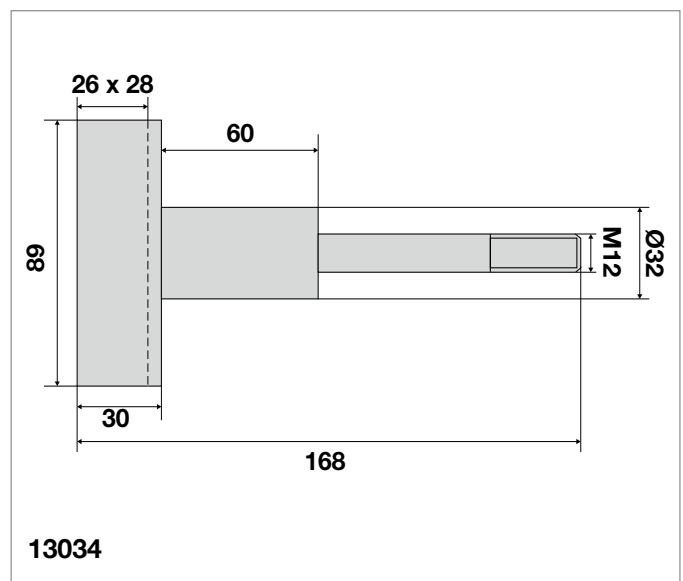
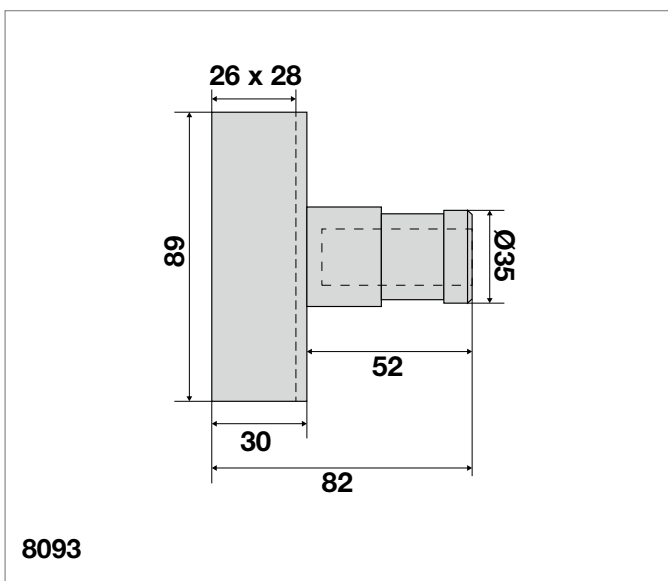

Codice / Code	Descrizione
8093	Porta pattino in metallo per guida arcata OTIS
13034	Porta pattino in metallo guida arcata L.90 FALCONI corto
13035	Porta pattino in alluminio per guida

PULEGGE DI TRAZIONE E RINVIO TRACTION AND TAIL SHEAVE



Materiale disponibile solo su ordinazione

Altre pulegge su richiesta precisare misure A V P.Max ed R

PULEGGE PORTANTI DI RINVIO

Ø P mm	Funi	A mm	R mm	Ø P mm	Funi	A mm	R mm
400	3x9+10	60	50	500	5x9+11	94	50
400	4x9+10	77	50	500	6x9+11	111	50
400	5x9+10	94	50	500	3x12	77	50
400	6x9+10	111	50	500	4x12	94	50
450	3x9+11	60	50	500	5x12	111	50
450	4x9+11	77	50	500	6x12	130	50
450	5x9+11	94	50	550	3x12+13	77	50
450	6x9+11	111	50	550	4x12+13	94	50
500	3x9+11	60	50	550	5x12+13	111	50
500	4x9+11	77	50	550	6x12+13	130	55

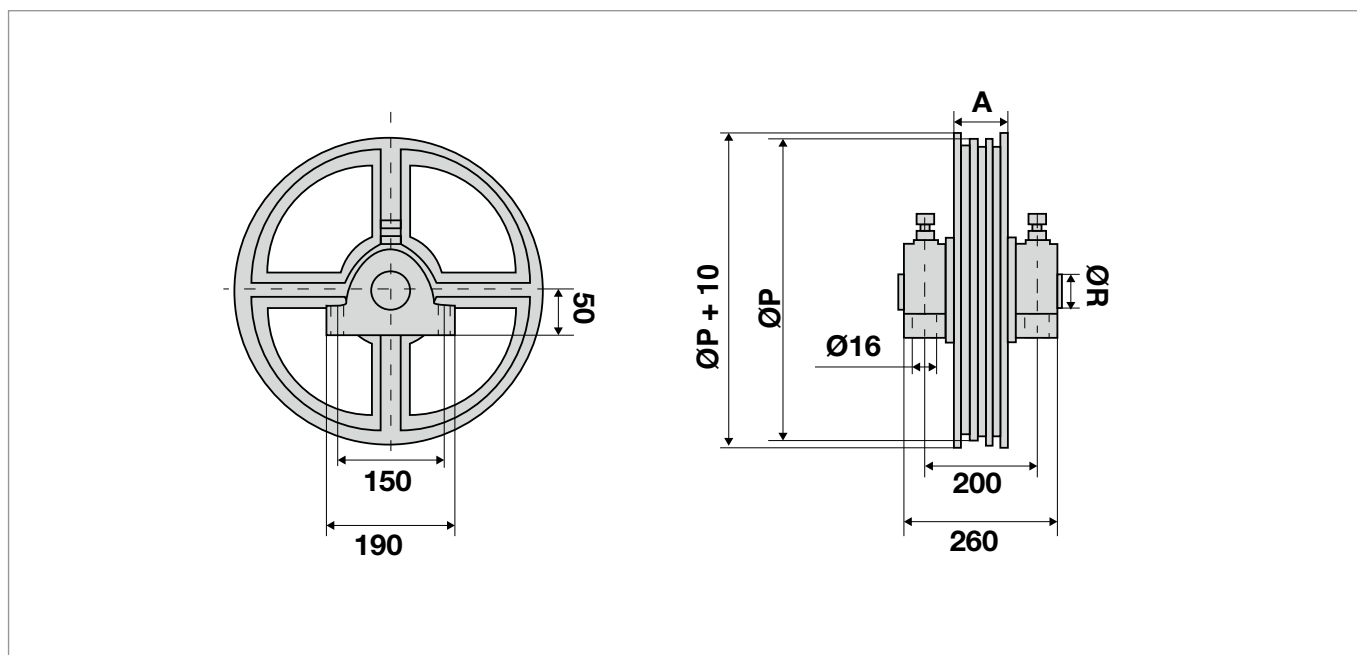

PATTINI, GUARNIZIONI, LARDONI PER GUIDE
GUIDE SHOE, GIB FOR GUIDE RAILS

Lardoni FIAM a 2 perni	19.17
<i>Guide shoes FIAM with 2 pivot</i>	
Lardoni OTIS in 3 pezzi a 1 perno	19.15
<i>OTIS Guide shoes in 3 pieces with 1 pivot</i>	
Pattini guida BASSETTI	19.17
<i>Guide shoe BASSETTI</i>	
Pattini guida FALCONI corto e lungo	19.15
<i>Guide shoe FALCONI short and long</i>	
Pattini guida FIAM BLP - Pattini guida FIAM tipo N	19.14
<i>Guide shoe FIAM BLP - Guide shoe FIAM type N</i>	
Pattini guida FIAM Vecchio lungo e Nuovo corto - tubetto in gomma per pattino guida FIAM	19.13
<i>Guide shoe FIAM long old and short new - rubber tube for guide shoe FIAM</i>	
Pattini guida FURINI	19.14
<i>Guide shoe FURINI</i>	
Pattini guida IGV	19.18
<i>Guide shoe IGV</i>	
Pattini guida SABIEM - Pattini arcata SABIEM	19.20
<i>SABIEM guide shoe - car frame guide shoe SABIEM</i>	
Pattini guida SABIEM L.200	19.21
<i>SABIEM guide shoe L.200</i>	
Pattino guida SALIVETTO	19.16
<i>Guide shoe SALIVETTO</i>	
Pattini guida SAFOV	19.21
<i>Guide shoe SAFOV</i>	
Pattini guida SCHINDLER L.100 - L.135 - L.180	19.19
<i>Guide shoe SCHINDLER L.100 - L.135 - L.180</i>	

Pattini guida SCHLIEREN	19.14
<i>Guide shoe SCHLIEREN</i>	
Pattini standard utilizzati da varie marche BASSETTI, FALCONI, FIAM, ect...	19.6-19.7-19.8-19.9-19.10-19.11-19.12
<i>Guide shoes Standard for various brands BASSETTI, FALCONI, FIAM, ect,..</i>	
PATTINI MONOBLOCCO	
ONE-PIECE SLIDING SHOE	
Pattino monoblocco AKRON	19.22
<i>One-piece sliding shoe AKRON</i>	
Pattino monoblocco BASSETTI	19.22
<i>One-Piece Sliding Shoe BASSETTI</i>	
PATTINI FUNE	
ROPE GUIDE SHOE	
Pattini Standard multi marche a 3 funi	19.25
<i>Guide shoes Standard various brands with 3 rope</i>	
Pattini BASSETTI a 2 funi - Pattini BASSETTI ROMBO 1 fune	19.26
<i>Guide shoes BASSETTI with 2 ropes - Guide shoe BASSETTI ROMBO 1 rope</i>	
Pattini FALCONI 3 funi	19.24
<i>Guide shoes FALCONI 3 rope</i>	
Pattini FIAM A 1 e a 2 funi	19.23
<i>Guide shoes FIAM A 1 and 2 rope</i>	
Pattini FORSID/MONITOR a 3 funi	19.25
<i>Guide shoes FORSID/MONITOR with 3 rope</i>	
Pattini OTIS 1 fune	19.23
<i>Guide shoes OTIS 1 rope</i>	
Pattini SABIEM 1 fune	19.23
<i>Guide shoes SABIEM 1 rope</i>	
Pattini SCHINDLER 1 fune rotondo - Pattini SCHINDLER 1 fune quadrato	19.24
<i>Guide shoes SCHINDLER 1 round rope - Guide shoe SCHINDLER1 square rope</i>	

PATTINI C/PESO
COUNTER WEIGHT GUIDE SHOE

Pattino c/peso a squadra	19.29
<i>Guide shoes c/weight in rectangular</i>	
Pattini c/peso standard quadro 70x65	19.30
<i>Standard guide shoes c/weight rectangular 70x65</i>	
Pattini c/peso standard con bussole	19.29
<i>Standard guide shoes c/weight with bushes</i>	
Pattini c/peso DELTA	19.30
<i>DELTA guide shoe c/weight</i>	
Pattini c/peso FIAM L.94	19.28
<i>Guide shoes c/weight FIAM L.94</i>	
Pattini c/peso FIAM L.112	19.28
<i>Guide shoes c/weight FIAM L.112</i>	
Pattini c/peso ROMBO standard	19.28
<i>Guide shoes c/weight standard ROMBO</i>	
Pattini c/peso ROMBO standard largo	19.29
<i>Standard ROMBO large guide shoes c/weight</i>	
Pattini c/peso SABIEM	19.27
<i>Guide shoes c/weight SABIEM</i>	
Pattini c/peso con lamella SABIEM	19.27
<i>Guide shoes c/weight with blade SABIEM</i>	
Pattini c/peso SAFOV	19.27
<i>Guide shoes c/weight SAFOV</i>	
Pattini c/peso SCHINDLER	19.27
<i>Guide shoes c/weight SCHINDLER</i>	

PATTINI PORTE AUTOMATICHE SCORREVOLI
GUIDE SHOES FOR AUTOMATIC AND SLIDING DOORS

Pattini a farfalla per soglia cava 12 -14 e 26 mm	19.33
<i>Butterfly gib sill for slot 12 -14 and 26 mm</i>	
Pattino cancelli standard	19.33
<i>Guide shoes for standard gate door</i>	
Pattini per portine a squadra lungo e corto	19.33
<i>Guide shoes Long and short for square door</i>	
Pattini soglia BASSETTI	19.31
<i>Gibs sill BASSETTI</i>	
Pattini soglia FALCONI	19.31
<i>Gibs sill FALCONI</i>	
Pattini soglia FIAM porta automatica e porta automatica S	19.32
<i>Gibs sill FIAM automatic door and automatic door S</i>	
Pattini soglia FORSID/MONITOR per porta automatica tipo Zip e tipo 92VF	19.32
<i>Gibs sill FORSID/MONITOR for automatic door type Zip and type 92VF</i>	
Pattino soglia OTIS M0 251 AWI - OTIS LM - OTIS 9779 mod.80 - OTIS ORLY	19.34
<i>Gibs sill OTIS M0 251 AWI - OTIS LM - OTIS 9779 mod.80 - OTIS ORLY</i>	
Pattini soglia SCHINDLER con feltrini	19.31
<i>Gibs sill SCHINDLER with felt</i>	
Pattini soglia SCHINDLER	19.31
<i>Gibs sill SCHINDLER</i>	
Pattino porte a ghigliottina OTIS TIEFFE	19.35
<i>Gibs guillotine doors OTIS TIEFFE</i>	

RONDELLE SPESSORAMENTO PORTA PATTINI
RUBBER WASHER SUPPORT GUIDE SHOE

Rondella grande morbida e rondella grande rigida	19.36
<i>Big soft rubber washer and big hard rubber washer</i>	
Rondella piccola morbida e rondella piccola rigida FIAM	19.36
<i>Big soft rubber washer and small hard rubber washer FIAM</i>	

Note: I componenti sul catalogo con riportata una specifica marca di ascensore sono utilizzati abitualmente solo da questa marca. I particolari senza marca sono utilizzati da più marche di ascensori.

Note: *The components in the catalogue with a specific lift brand are usually used only by the brand. Unbranded parts are used by multiple lift brands.*

PATTINI GUIDE SHOES

19

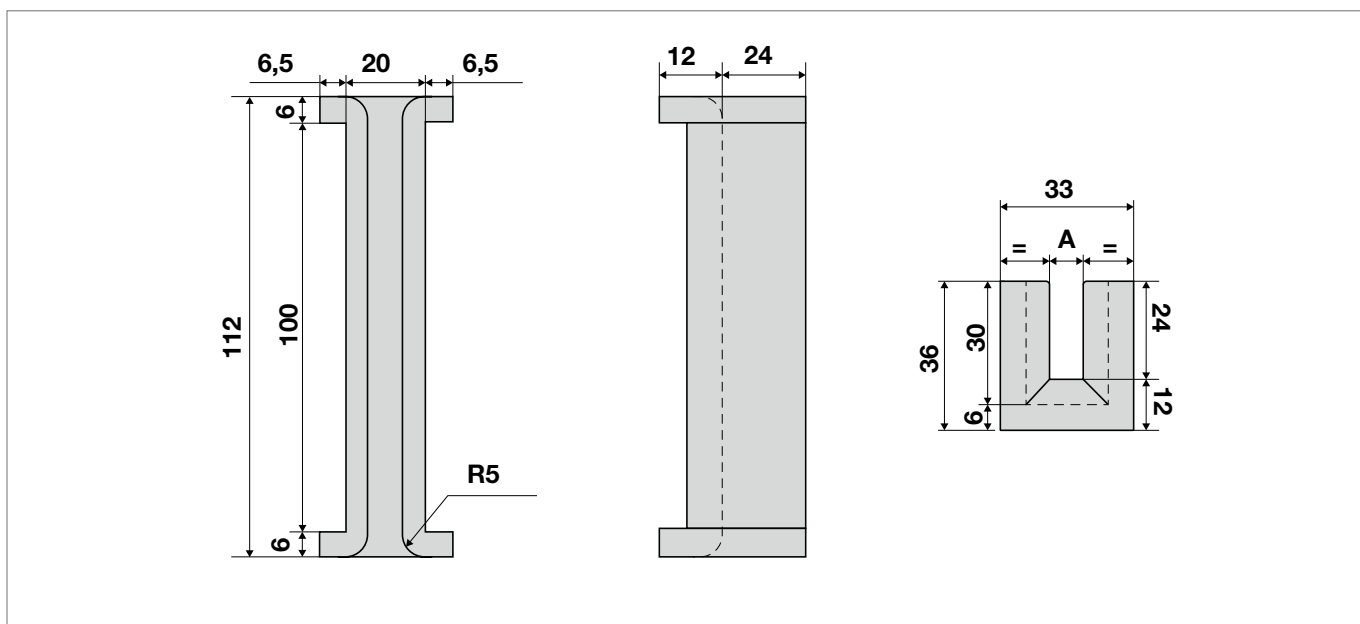
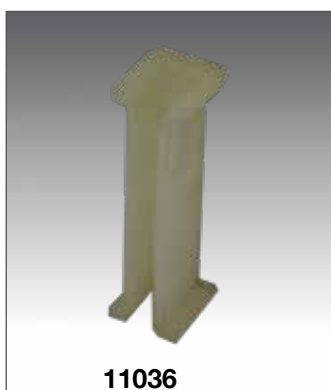
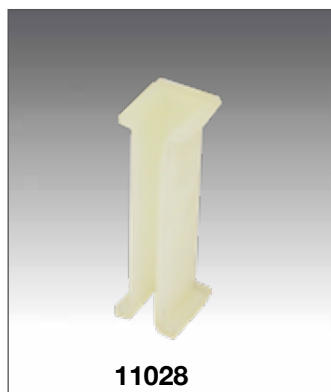

Codice / Code	Descrizione	Guida	A
11028	Pattino L.100 Desmopan	T50	6,5
11030	Pattino L.100 Desmopan	T60	7,5
11032	Pattino L.100 Desmopan	T70	8,5
11034	Pattino L.100 Desmopan	T80	9,5
11036	Pattino L.100 Desmopan	T100	10,5
11026	Pattino L.100 Desmopan	T12	12,5

PATTINI GUIDE SHOES

19

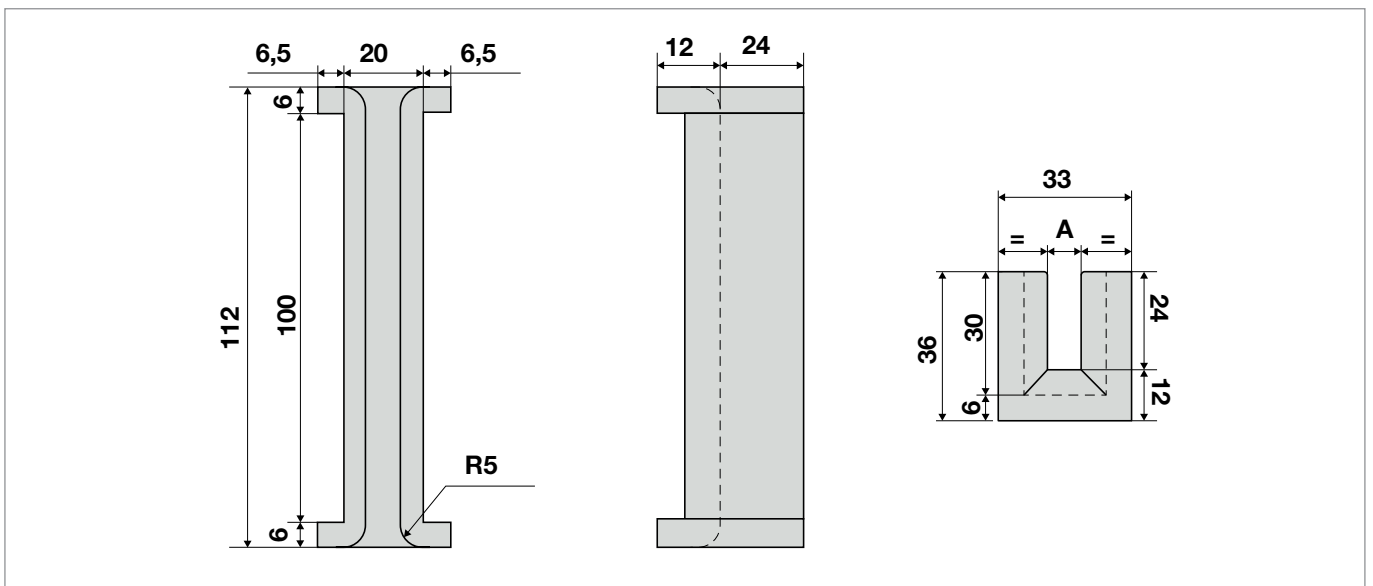
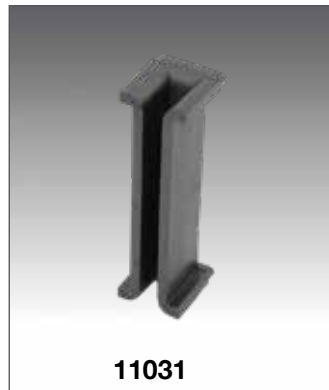

Codice / Code	Descrizione	Guida	A
11029	Pattino L.100 Nylon	T40	5,5
11031/1	Pattino L.100 Nylon	T50	6,5
11031	Pattino L.100 Nylon	T60	7,5
11033	Pattino L.100 Nylon	T70	8,5
11035	Pattino L.100 Nylon	T80	9,5
11037	Pattino L.100 Nylon	T100	10,5
11039	Pattino L.100 Nylon	T12	12,5

PATTINI GUIDE SHOES

19

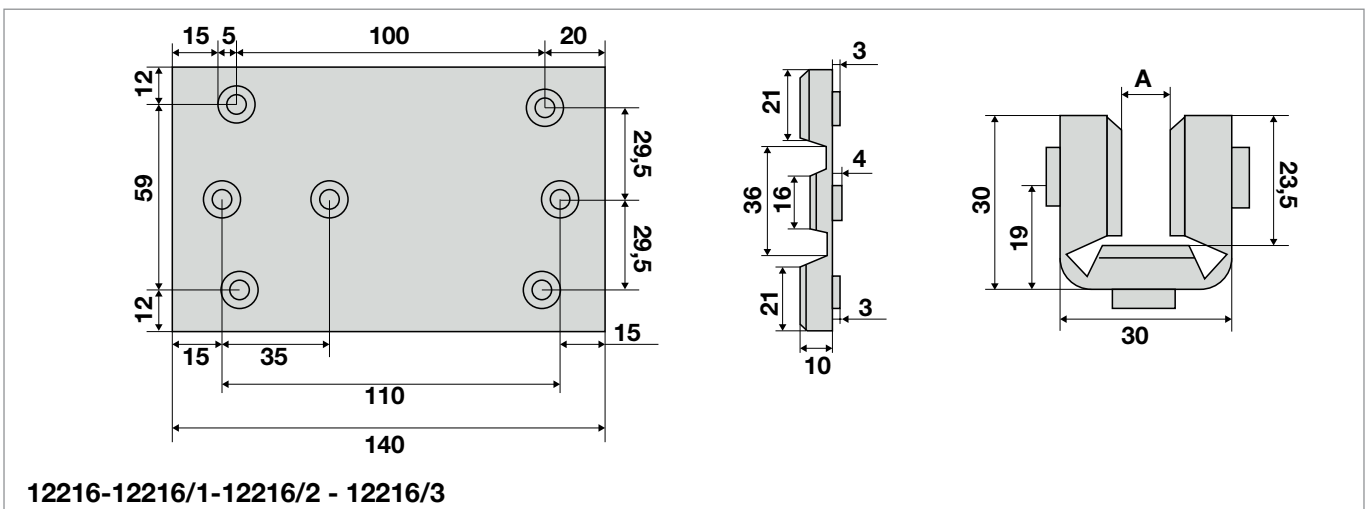
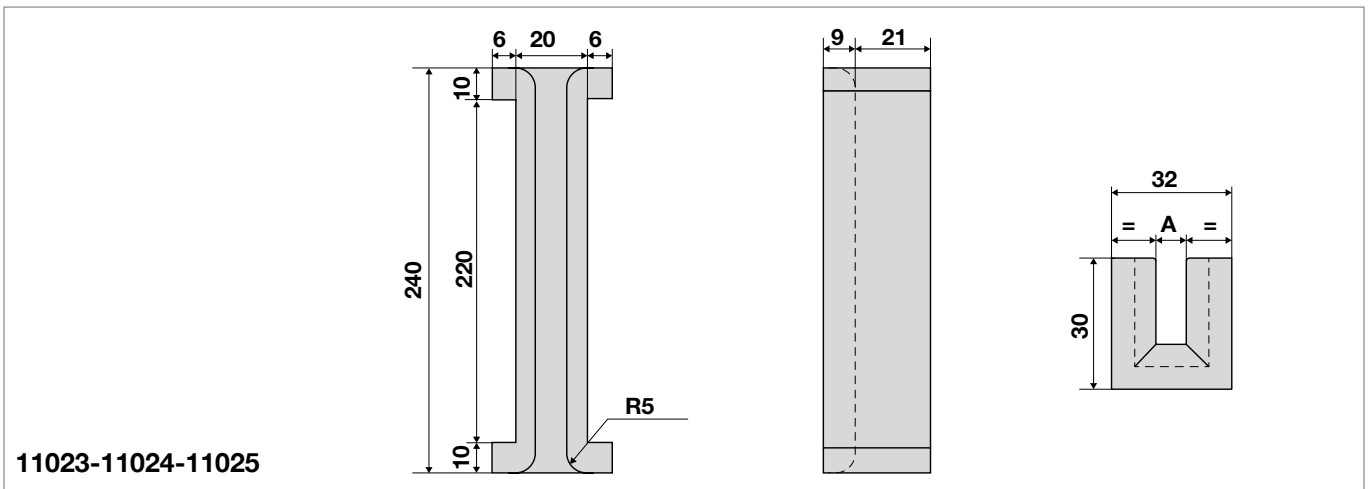

Codice / Code	Descrizione	Guida	A
11023	Pattino L.220	T70	8,5
11024	Pattino L.220	T80	9,5
11025	Pattino L.220	T100	10,5

Codice / Code	Descrizione	Guida	A
12216	Pattino per supporto pattino cod. 13035	T8	8,5
12216/1	Pattino per supporto pattino cod. 13035	T9	9,5
12216/2	Pattino per supporto pattino cod. 13035	T10	10,5
12216/3	Pattino per supporto pattino cod. 13035	T16	16,5

PATTINI GUIDE SHOES

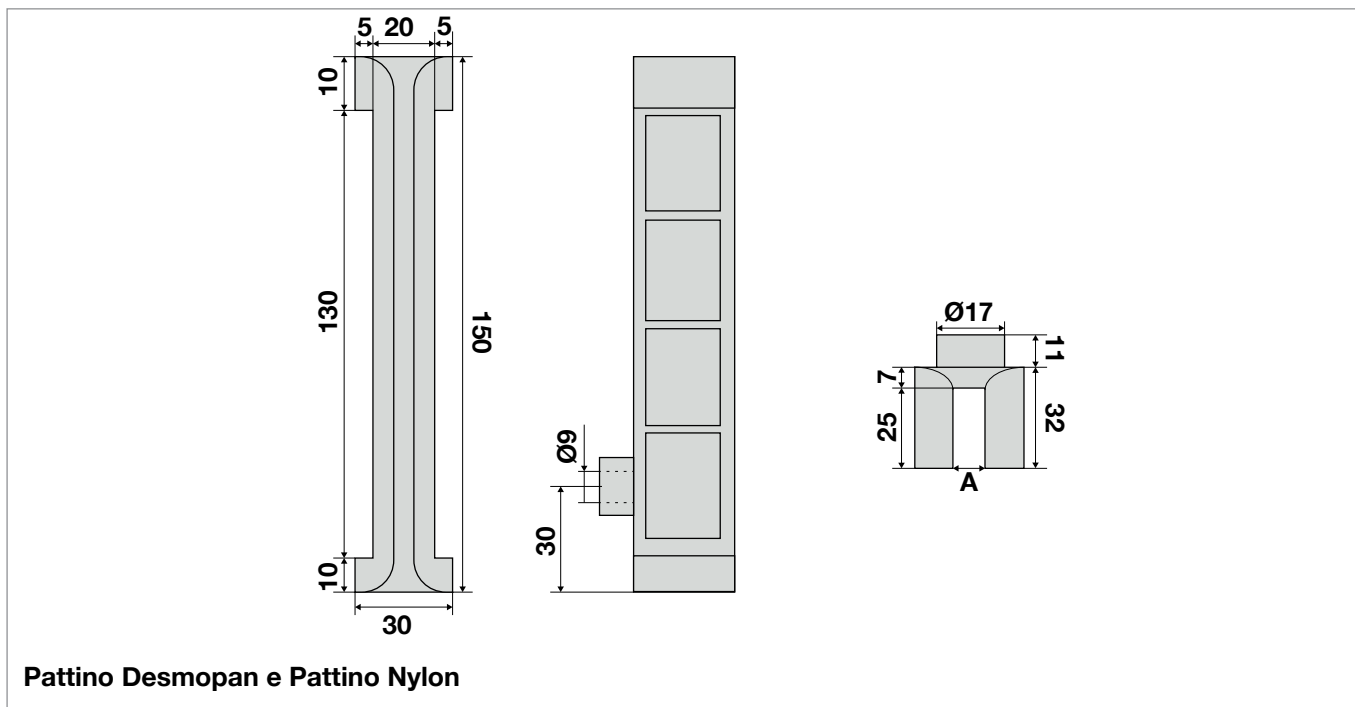

Codice / Code	Descrizione	Guida	A
11001	Pattino L.130 Desmopan	T50	6,5
11003	Pattino L.130 Desmopan	T60	7,5
11005	Pattino L.130 Desmopan	T70	8,5
11007	Pattino L.130 Desmopan	T80	9,5
11009	Pattino L.130 Desmopan	T100	10,5
11011	Pattino L.130 Desmopan	T12	12,5

Codice	Descrizione	Guida	A
11002	Pattino L.130 Nylon	T50	6,5
11004	Pattino L.130 Nylon	T60	7,5
11006	Pattino L.130 Nylon	T70	8,5
11008	Pattino L.130 Nylon	T80	9,5
11010	Pattino L.130 Nylon	T100	10,5
11012	Pattino L.130 Nylon	T12	12,5

PATTINI GUIDE SHOES

19

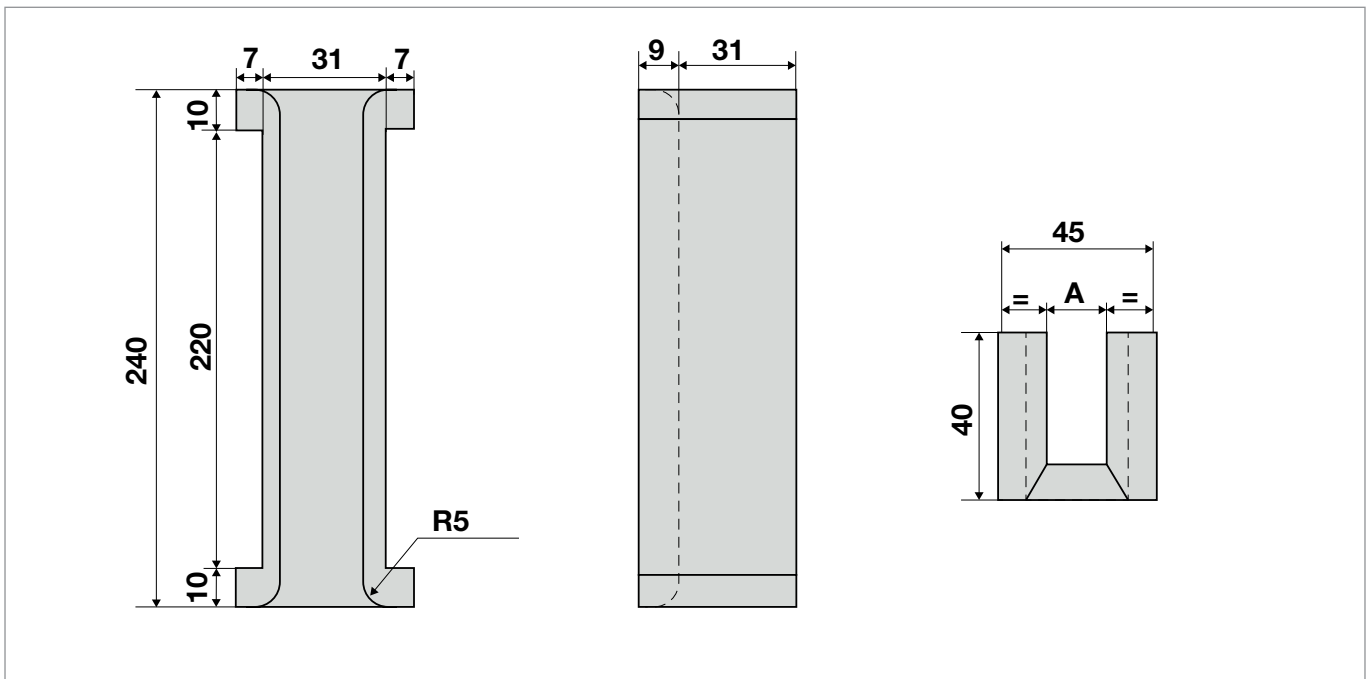

Codice / Code	Descrizione	Guida	A
11019	Pattino L.220	T70	8,5
11020	Pattino L.220	T80	9,5
11021	Pattino L.220	T100	10,5
11022	Pattino L.220	T12	12,5
11017	Pattino L.220	T14	14,5
11018	Pattino L.220	T16	16,5

PATTINI GUIDE SHOES

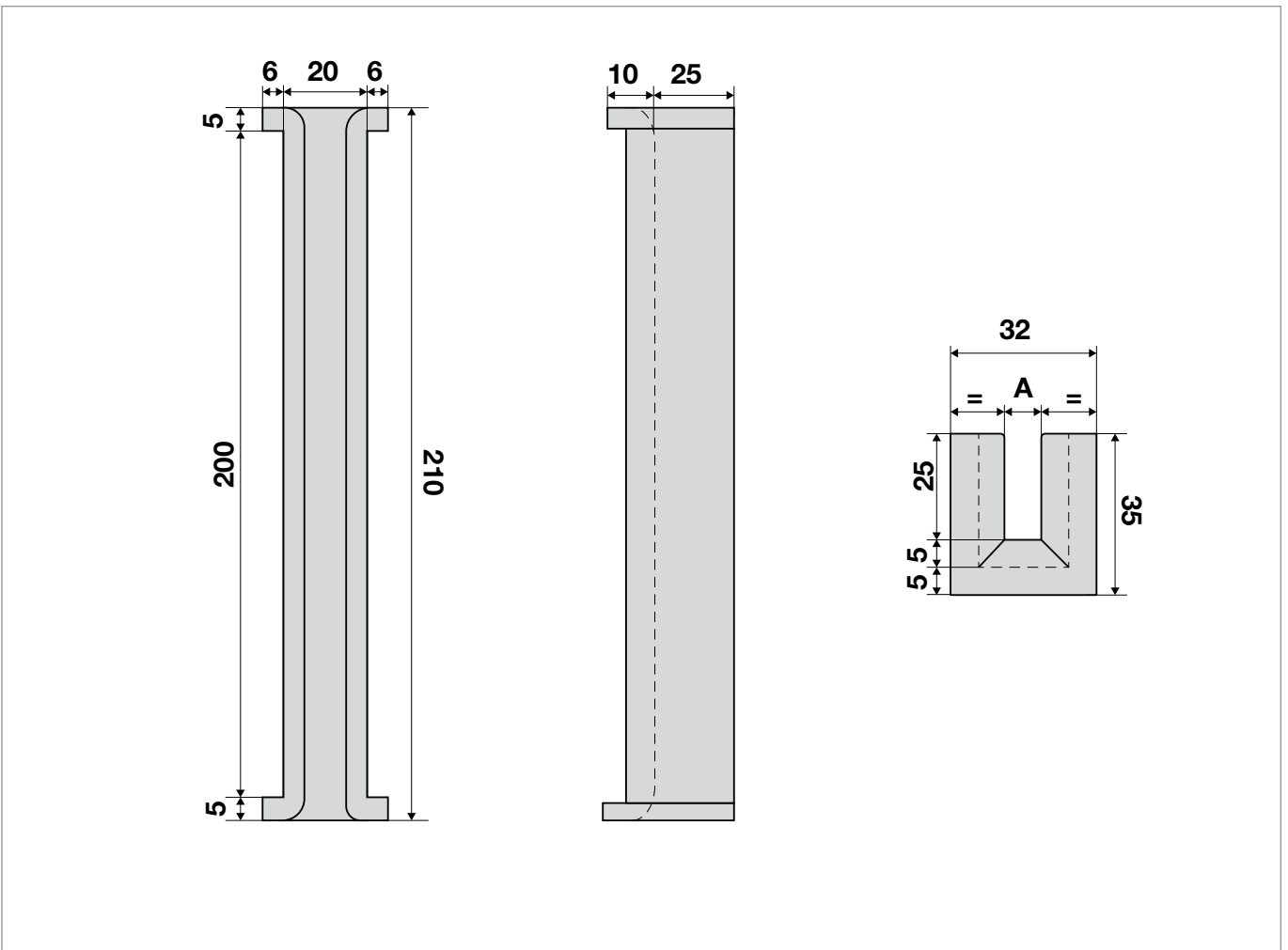

Codice / Code	Descrizione	Guida	A
11013	Pattino L.200	T70	8,5
11014	Pattino L.200	T80	9,5
11015	Pattino L.200	T100	10,5
11016	Pattino L.200	T12	12,5

PATTINI FIAM GUIDE SHOES FIAM



FIAM tipo vecchio



FIAM tipo nuovo

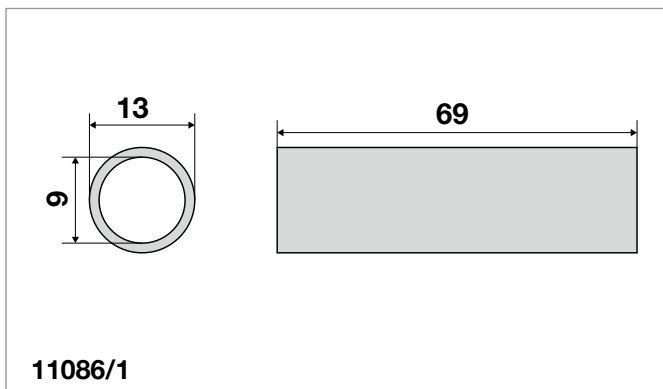

11086/1

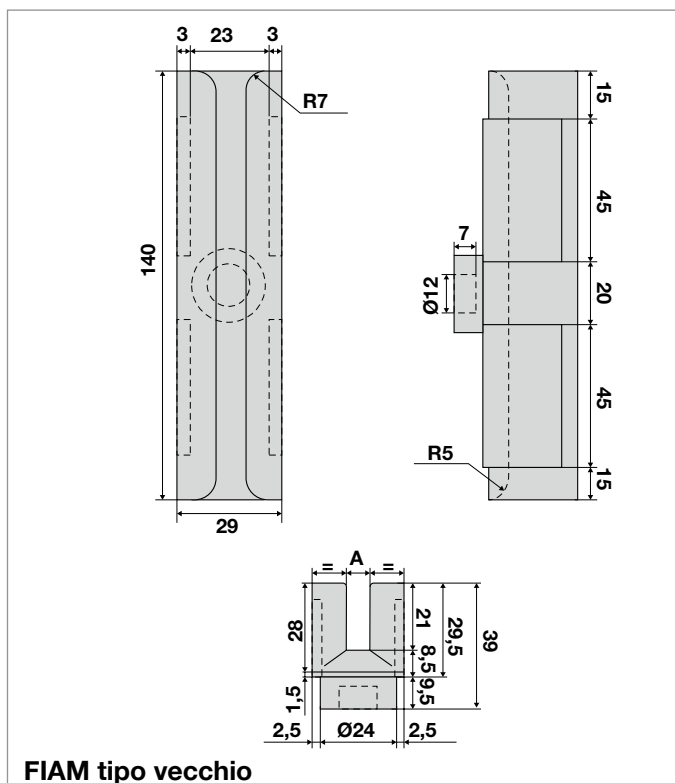

FIAM tipo vecchio

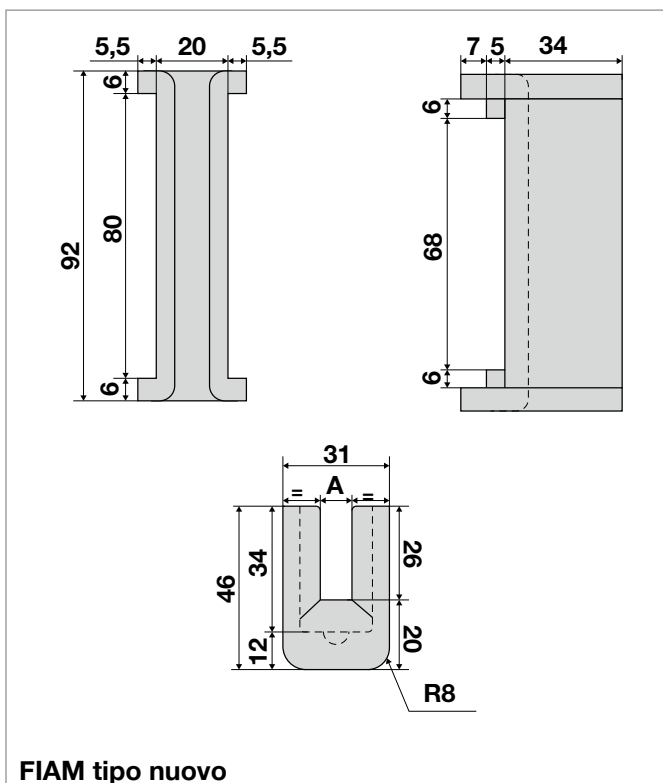

FIAM tipo nuovo

Codice / Code	Descrizione	Guida	A
11049	Pattino guida L.140 FIAM tipo vecchio	T60	7,5
11050	Pattino guida L.140 FIAM tipo vecchio	T70	8,5
11051	Pattino guida L.140 FIAM tipo vecchio	T80	9,5
11051/1	Pattino guida L.140 FIAM tipo vecchio	T90	10,5
11051/2	Pattino guida L.140 FIAM tipo vecchio	T12	12,5
11051/3	Pattino guida L.140 FIAM tipo vecchio	T14	14,5
Codice / Code	Descrizione	Guida	A
11052	Pattino guida L.80 FIAM tipo nuovo	T60	7,5
11053	Pattino guida L.80 FIAM tipo nuovo	T70	8,5
11054/1	Pattino guida L.80 FIAM tipo nuovo	T80	9,5
11054	Pattino guida L.80 FIAM tipo nuovo	T100	10,5
11086/1	Tubetto in gomma pattino guida FIAM		

PATTINI FIAM - FURINI - SCHLIEREN

GUIDE SHOES FIAM - FURINI - SCHINDLER

19

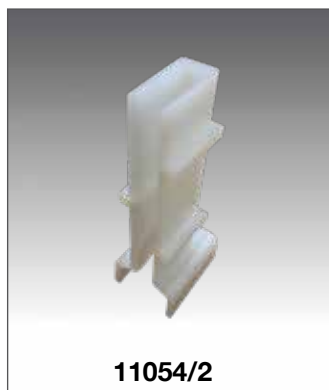

11054/2



FIAM "BLP"



12108



Pattino arcata FURINI

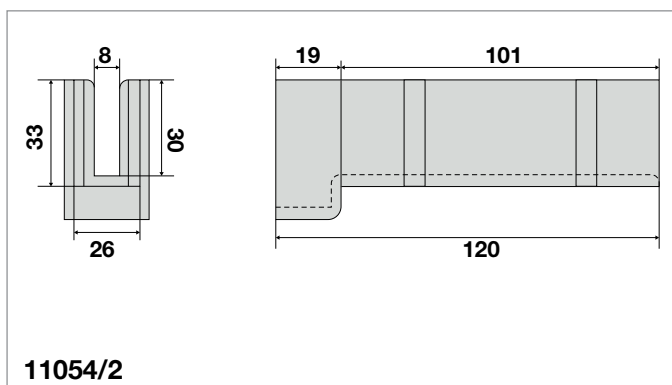

11054/2

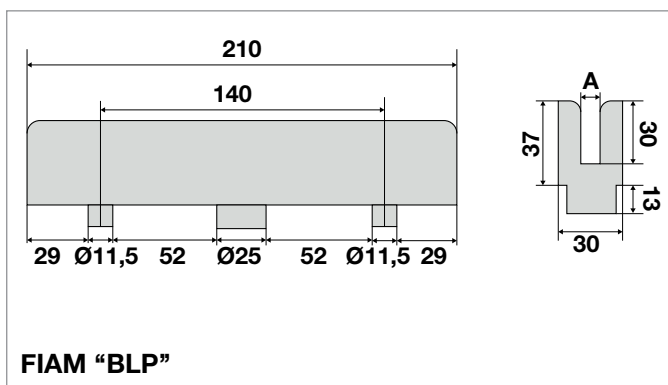

FIAM "BLP"

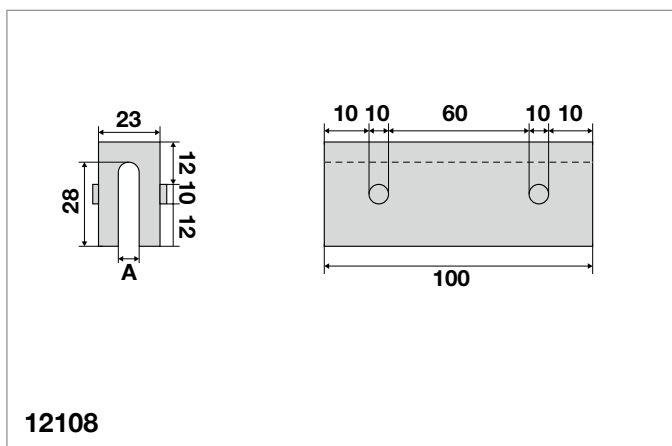

12108

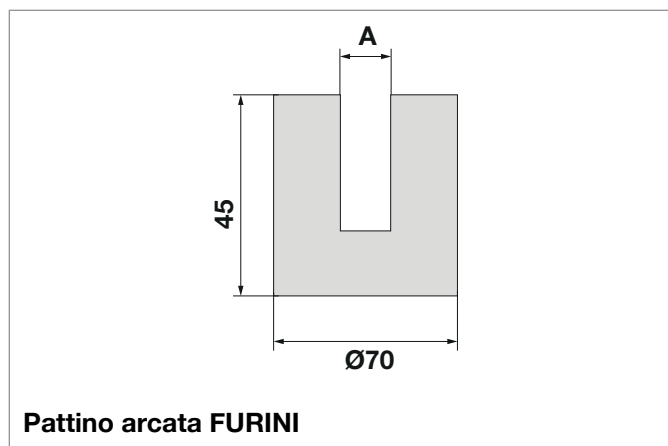

Pattino arcata FURINI

Codice / Code	Descrizione	Guida	A
11054/2	Pattino guida FIAM tipo "N"		
Codice / Code	Descrizione	Guida	A
11054/3	Pattino guida FIAM BLP	T12	12,5
11054/4	Pattino guida FIAM BLP	T16	16,5
Codice / Code	Descrizione	Guida	A
12108	Pattino guida SCHLIEREN	T90	10,5
Codice / Code	Descrizione	Guida	A
11082A	Pattino guida FURINI	T70	8,5
11082B	Pattino guida FURINI	T80	9,5
11082C	Pattino guida FURINI	T90	10,5

PATTINI FALCONI - OTIS GUIDE SHOES FALCONI - OTIS

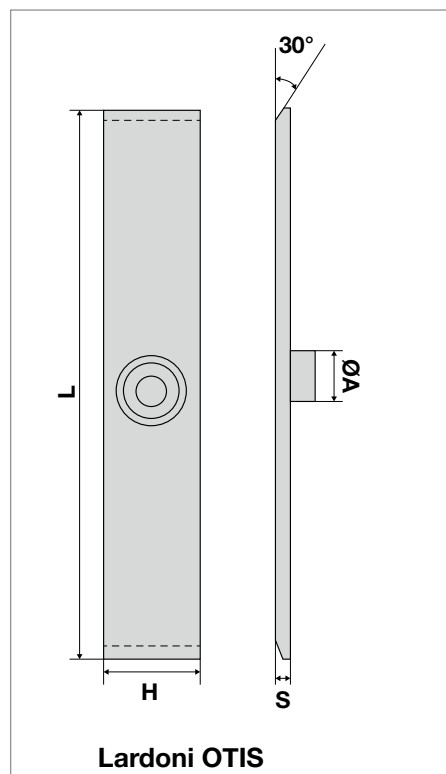
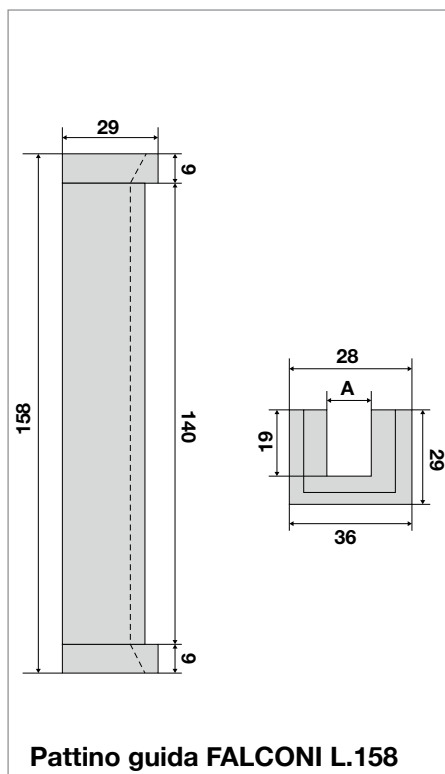
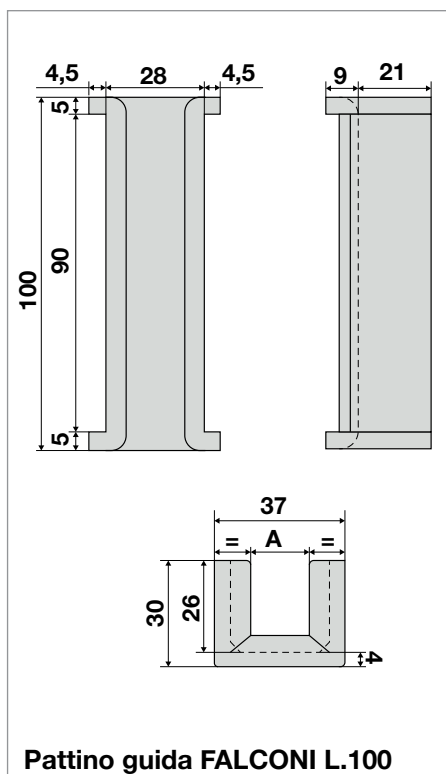

Codice	Descrizione (L.100)	Guida	A	Codice	Descrizione (L.158)	Guida	A
11060	Pattino per guida a "T" FALCONI	T60	7,5	11061/1	Pattino per guida a "T" FALCONI	T70	8,5
11061	Pattino per guida a "T" FALCONI	T70	8,5	11062/2	Pattino per guida a "T" FALCONI	T80	9,5
11062	Pattino per guida a "T" FALCONI	T80	9,5	11062/3	Pattino per guida a "T" FALCONI	T90	10,5
11063	Pattino per guida a "T" FALCONI	T100	10,5	11062/4	Pattino per guida a "T" FALCONI	T12	12,5
11064	Pattino per guida a "T" FALCONI	T12	12,5	11062/5	Pattino per guida a "T" FALCONI	T14	14,5
11065	Pattino per guida a "T" FALCONI	T14	14,5	11062/6	Pattino per guida a "T" FALCONI	T16	16,5
11066	Pattino per guida a "T" FALCONI	T16	16,5				

Composto da 3 pezzi

Codice	Descrizione	L	2 pz H	1 pz H	A	S	Codice	Descrizione	L	2 pz H	1 pz H	A	S
12211	Lardoni OTIS	120	25	16	14	5	12214	Lardoni OTIS	180	30	20	16	6
12212	Lardoni OTIS	130	30	20	16	6	12215	Lardoni OTIS	200	30	20	16	6
12213	Lardoni OTIS	150	30	20	16	6							

PATTINI SALIVETTO GUIDE SHOES SALIVETTO

19

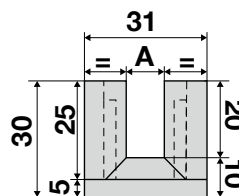
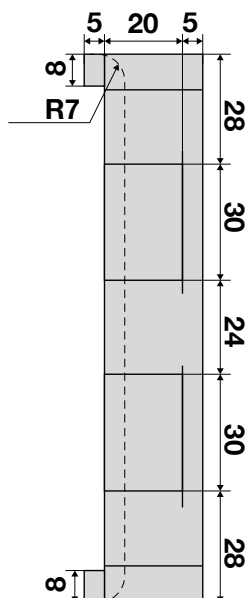
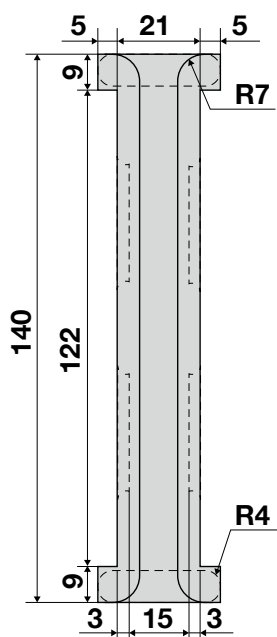

SALIVETTO

Codice	Descrizione	Guida	A
11059/1	Pattino guida SALIVETTO	T70	8,5
11059	Pattino guida SALIVETTO	T80	9,5

PATTINI BASSETTI - FIAM GUIDE SHOES BASSETTI - FIAM

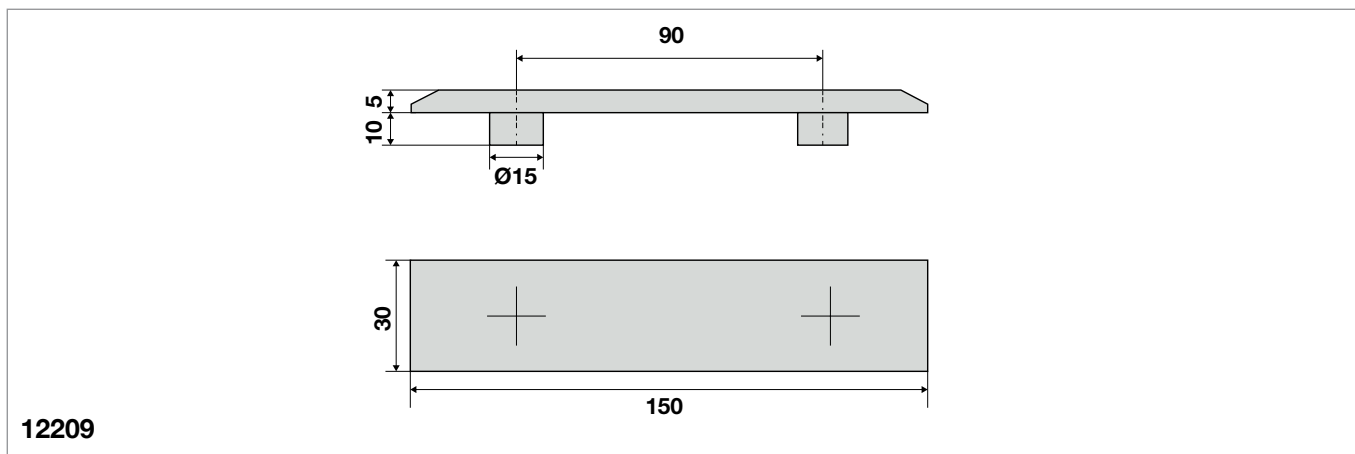
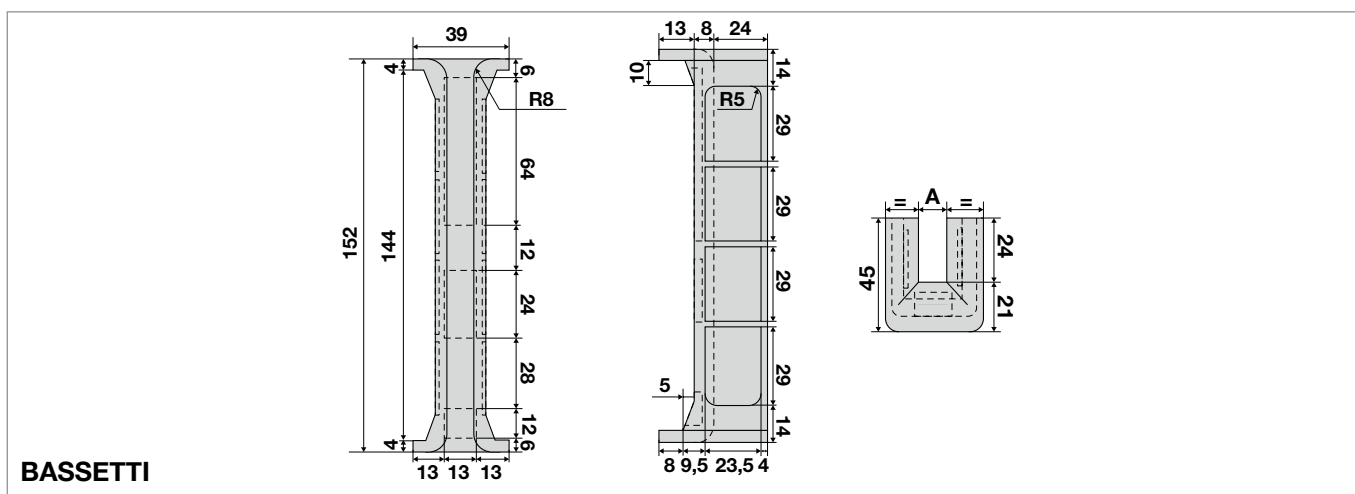

Codice	Descrizione	Guida	A
11055	Pattino guida BASSETTI L.144	T60	7,5
11056	Pattino guida BASSETTI L.144	T70	8,5
11057	Pattino guida BASSETTI L.144	T80	9,5
11057/A	Pattino guida BASSETTI L.144	T12	12,5
11057/B	Pattino guida BASSETTI L.144	T16	16,5

Codice / Code	Descrizione
12209	Lardone per pattino 2 perni diam.15 FIAM

PATTINI IGV GUIDE SHOES IGV

19

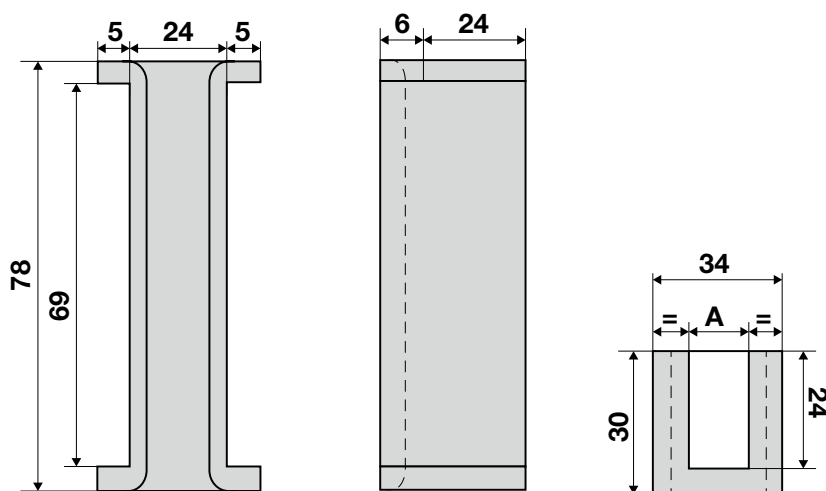

Pattino guida IGV

Codice	Descrizione	Guida	A
12217	Pattino guida IGV L901801 69 x 24	T70	8,5
12217/1	Pattino guida IGV L901801 69 x 24	T80	9,5
12217/2	Pattino guida IGV L901801 69 x 24	T16	16,5

PATTINI GUIDE SCHINDLER

GUIDE SHOES SCHINDLER

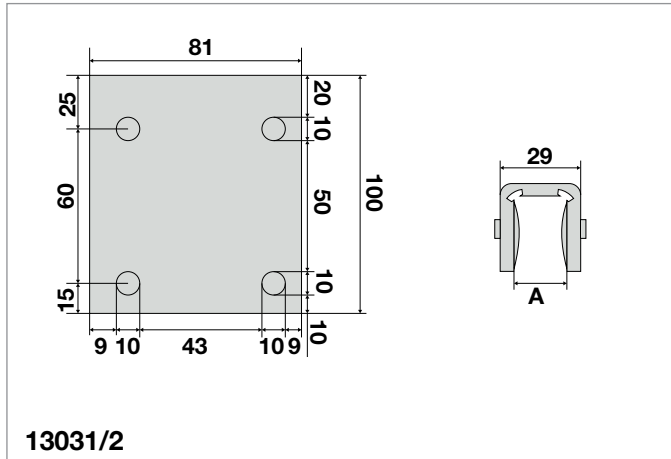
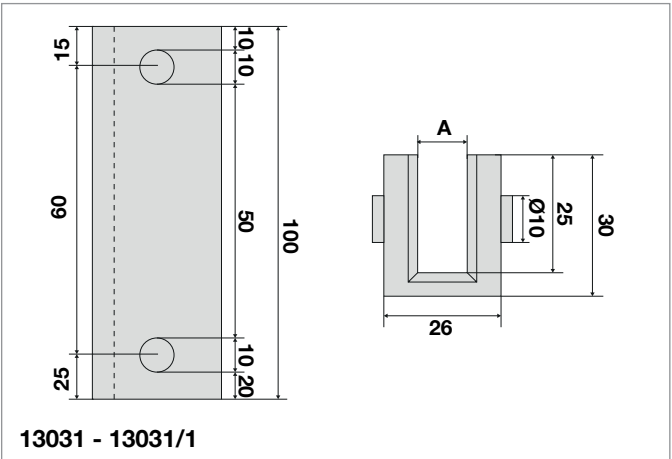
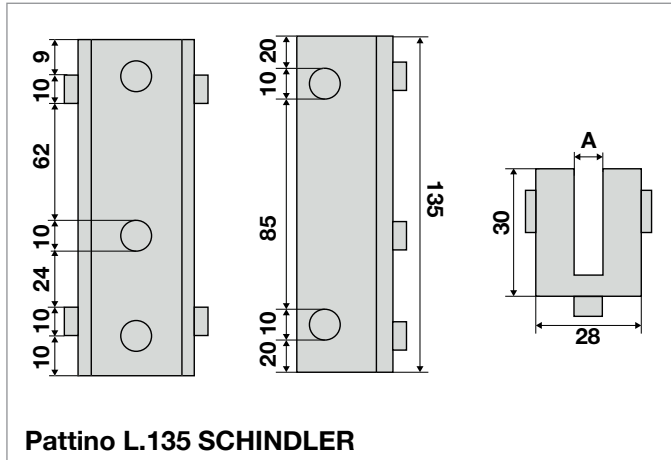
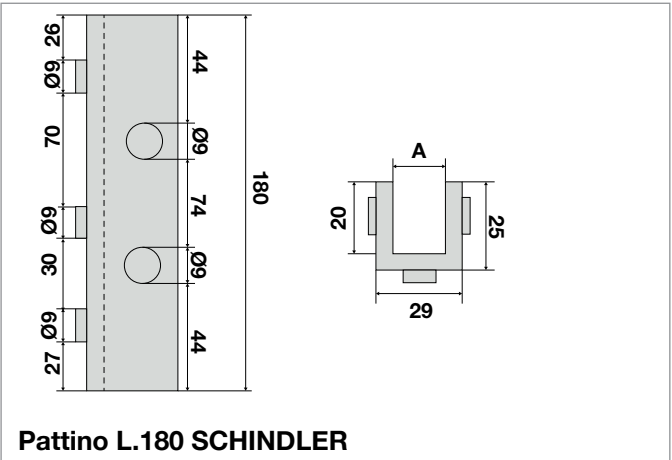
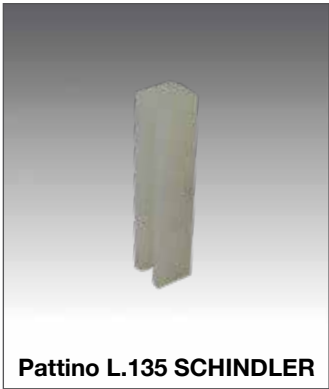

Codice	Descrizione	Guida	A	Codice	Descrizione	Guida	A
11069	Pattino L.180 SCHINDLER	T50	6,5	11073	Pattino L.135 SCHINDLER	T60	7,5
11070	Pattino L.180 SCHINDLER	T60	7,5	11074	Pattino L.135 SCHINDLER	T70	8,5
11071	Pattino L.180 SCHINDLER	T70	8,5	11075	Pattino L.135 SCHINDLER	T80	9,5
11072	Pattino L.180 SCHINDLER	T80	9,5	11075/1	Pattino L.135 SCHINDLER	T12	12,5
11072/1	Pattino L.180 SCHINDLER	T90	10,5	11075/2	Pattino L.135 SCHINDLER	T16	16,5

Codice / Code	Descrizione	Guida	A
13031	Pattino L.100 SCHINDLER	T70	8,5
13031/1	Pattino L.100 SCHINDLER	T80	9,5
13031/2	Pattino L.100 SCHINDLER in elastolane silenzioso (Acla)	T70	8,5
13031/3	Pattino L.100 SCHINDLER	T90	10,5

PATTINI GUIDE SABIEM GUIDE SHOES SABIEM

19



Pattino guida SABIEM

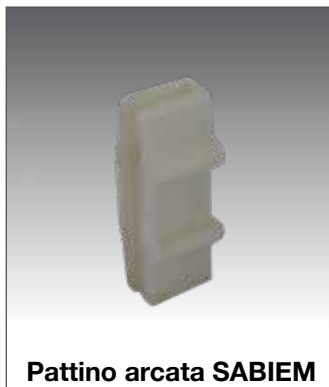

Pattino arcata SABIEM

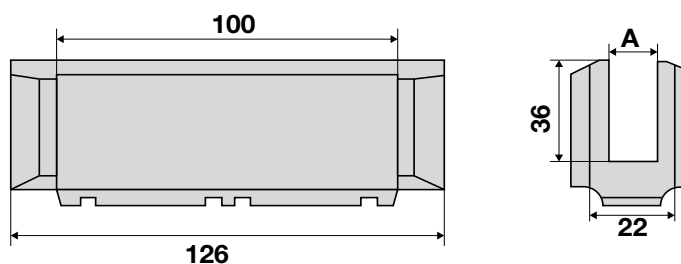

Pattino guida SABIEM

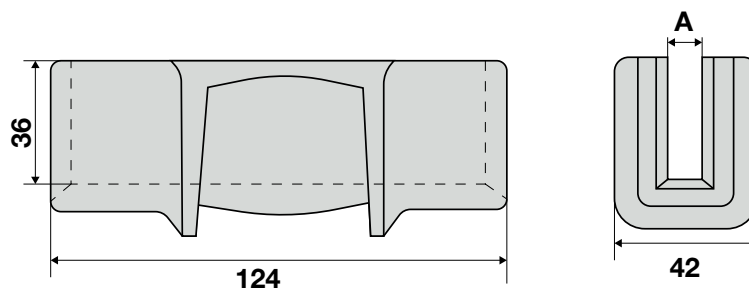

Pattino arcata SABIEM

Codice / Code	Descrizione	Guida	A
11081/1	Pattino guida SABIEM	T60	7,5
11081/2	Pattino guida SABIEM	T70	8,5
11081	Pattino guida SABIEM	T80	9,5
11081/4	Pattino guida SABIEM	T12	12,5

Codice / Code	Descrizione	Guida	A
11082/1	Pattino arcata SABIEM	T60	7,5
11082	Pattino arcata SABIEM	T70	8,5
11082/2	Pattino arcata SABIEM	T80	9,5
11082/3	Pattino arcata SABIEM	T90	10,5
11082/4	Pattino arcata SABIEM	T12	12,5

PATTINI GUIDE SAFOV - SABIEM GUIDE SHOES SAFOV - SABIEM

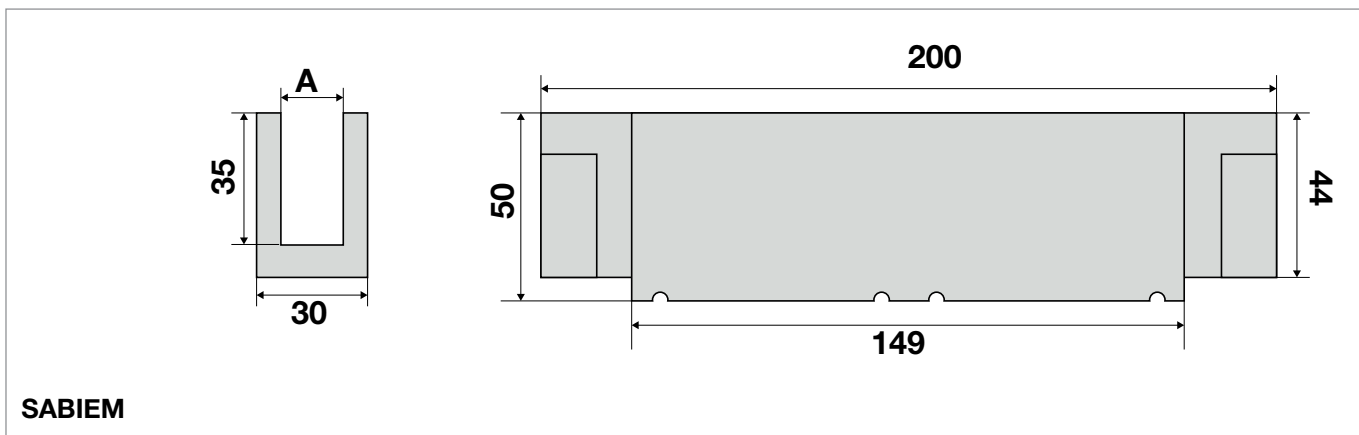
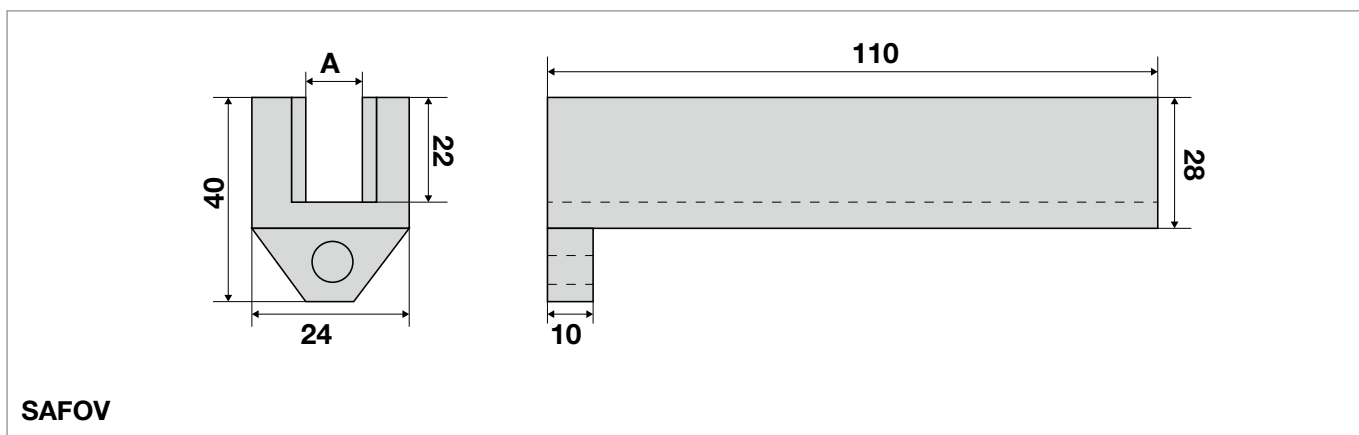

Codice / Code	Descrizione	Guida	A
11076	Pattino guida SAFOV L.110	T50	6,5
11077	Pattino guida SAFOV L.110	T60	7,5
11078	Pattino guida SAFOV L.110	T70	8,5
11079	Pattino guida SAFOV L.110	T80	9,5

Codice / Code	Descrizione	Guida	A
11082/5	Pattino guida SABIEM L.200	T 70	8,5
11082/6	Pattino guida SABIEM L.200	T12	12,5
11082/7	Pattino guida SABIEM L.200	T16	16,5

PATTINI MONOBLOCCO GUIDE AKRON - BASSETTI

ONE-PIECE SLIDING SHOE AKRON - BASSETTI

19

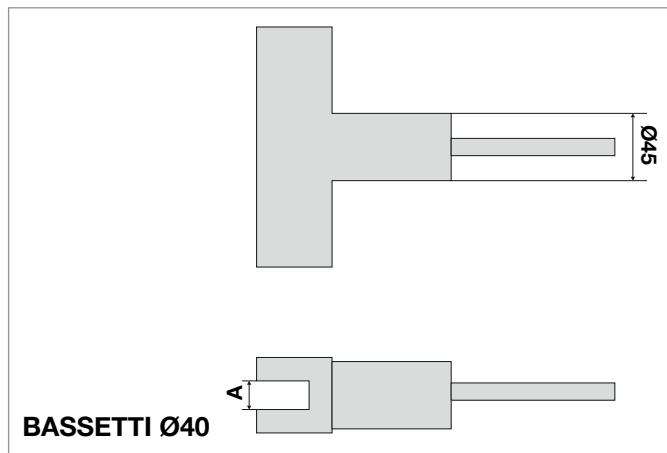
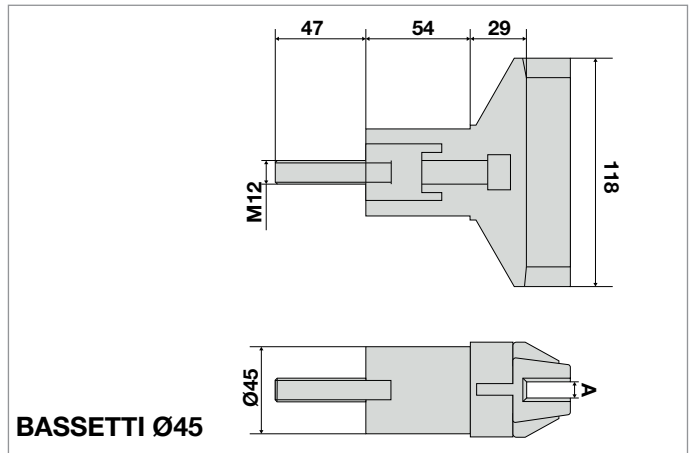
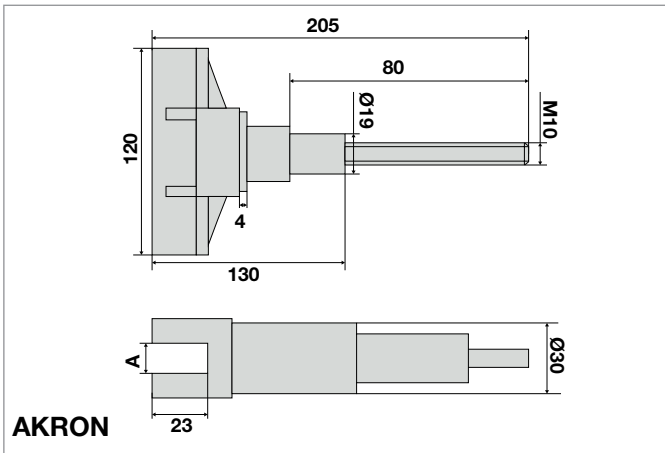

Codice / Code	Descrizione	Guida	A
11058/2	Pattino monoblocco AKRON Diam.30	T60	7,5
11058/1	Pattino monoblocco AKRON Diam.30	T80	9,5

Codice	Descrizione	Guida	A	Codice	Descrizione	Guida	A
11057/2	Pattino monoblocco arcata cabina BASSETTI Diam.45	T60	7,5	11057/7	Pattino monoblocco arcata cabina BASSETTI Diam.40	T60	7,5
11057/3	Pattino monoblocco arcata cabina BASSETTI Diam.45	T70	8,5	11057/6	Pattino monoblocco arcata cabina BASSETTI Diam.40	T70	8,5
11057/4	Pattino monoblocco arcata cabina BASSETTI Diam.45	T80	9,5	11057/8	Pattino monoblocco arcata cabina BASSETTI Diam.40	T80	9,5

PATTINI FUNE FIAM - SABIEM - OTIS
GUIDE SHOES FOR ROPES FIAM - SABIEM - OTIS

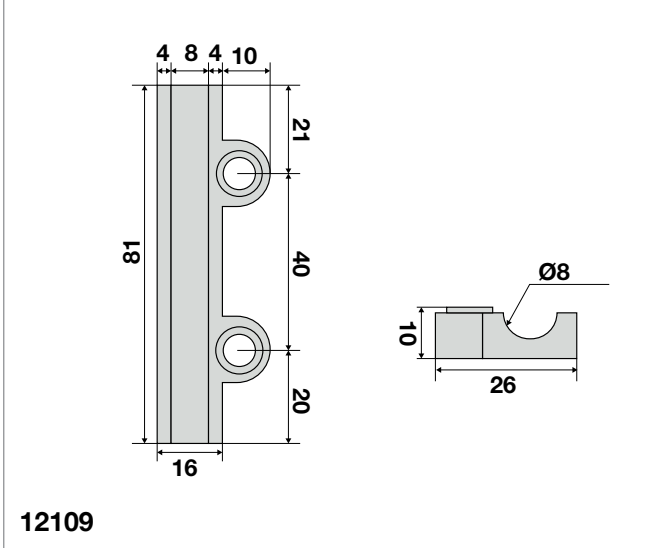
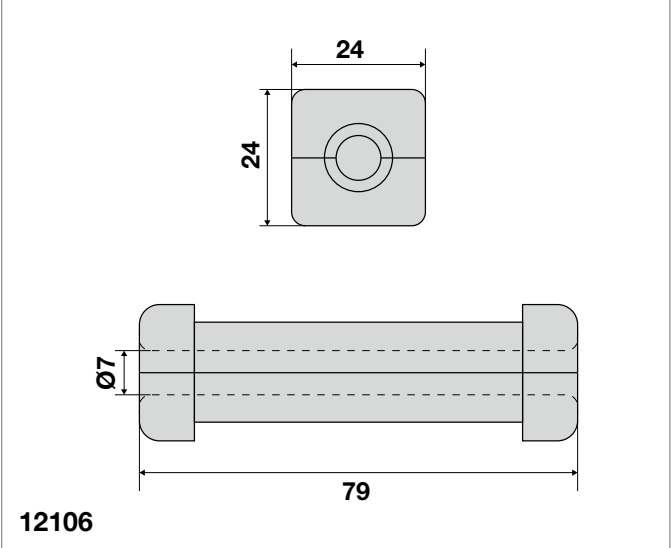
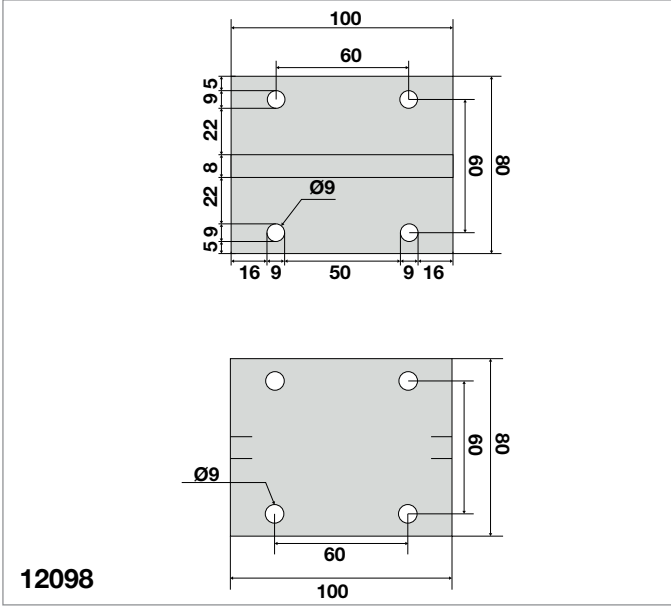
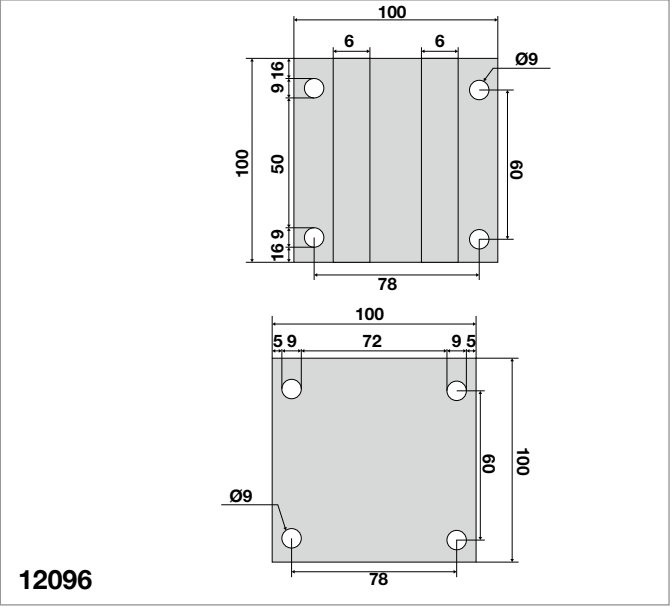

Codice / Code	Descrizione
12095	Pattino guida c/peso guidato bord. 1 o 2 funi
12096	Pattino c/peso a 2 funi FIAM per fune Ø 6 (codice per 1 coppia)
12098	Pattino c/peso a 1 fune FIAM per fune Ø 8 (codice per 1 coppia)
12106	Pattino fune SABIEM (codice per 1 coppia)
12109	Pattino fune OTIS (codice per 1 coppia)

PATTINI FUNE SCHINDLER - FALCONI GUIDE SHOES FOR ROPES SCHINDLER - FALCONI

19

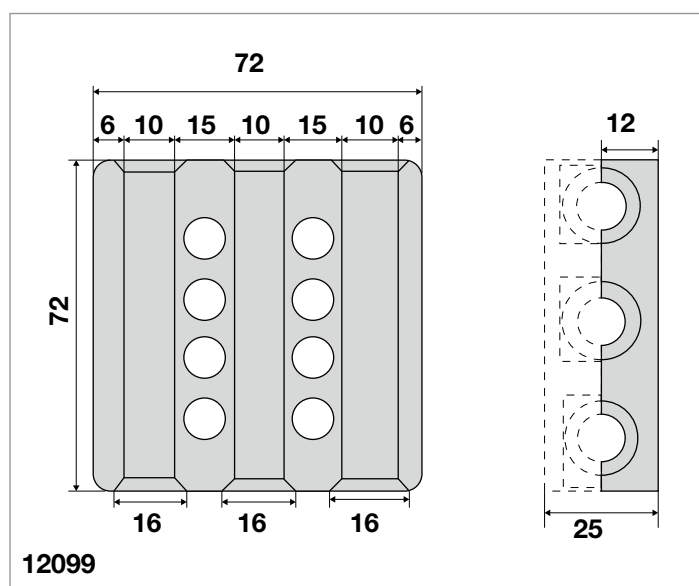
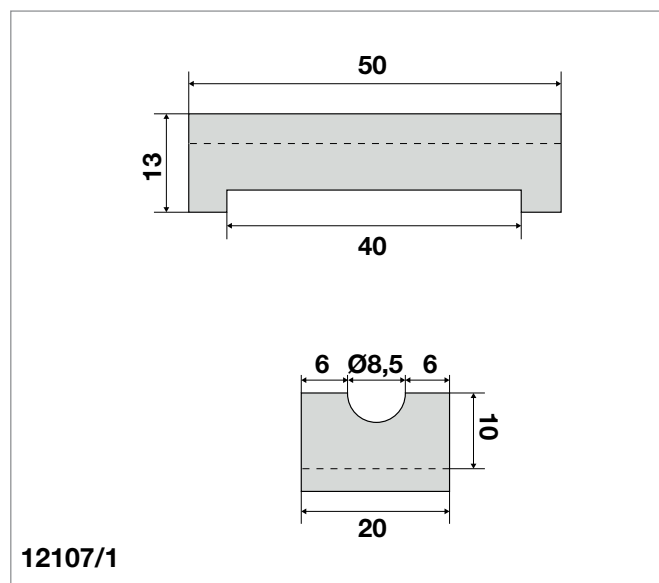
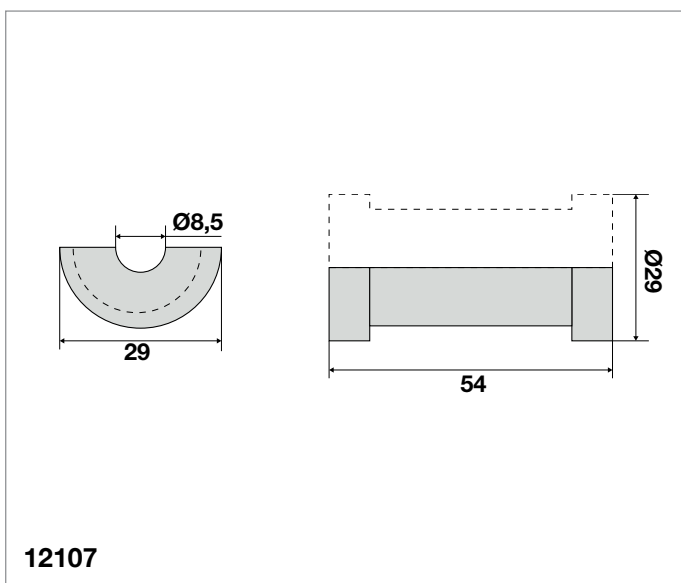

Codice / Code	Descrizione
12107	Pattino fune SCHINDLER rotondo per fune Ø 8 (codice per 1 coppia)
12107/1	Pattino fune SCHINDLER quadrato 50 x 20 per fune Ø 8 (codice per 1 coppia)
12099	Pattino fune FALCONI (codice per 1 coppia)

PATTINI FUNE FORSID/MONITOR - STANDARD

GUIDE SHOES FOR ROPES FORSID/MONITOR - STANDARD

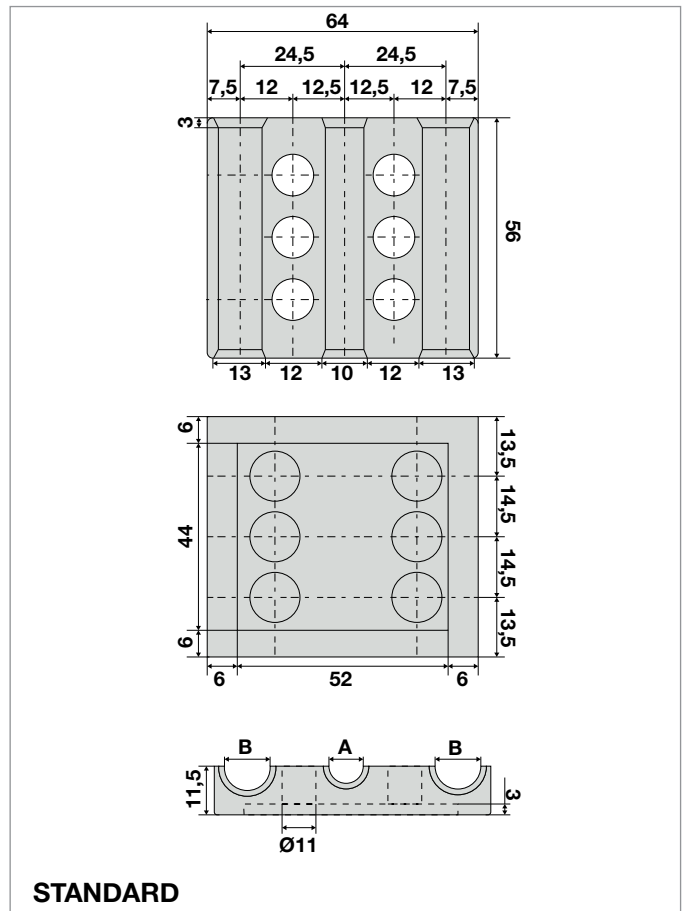
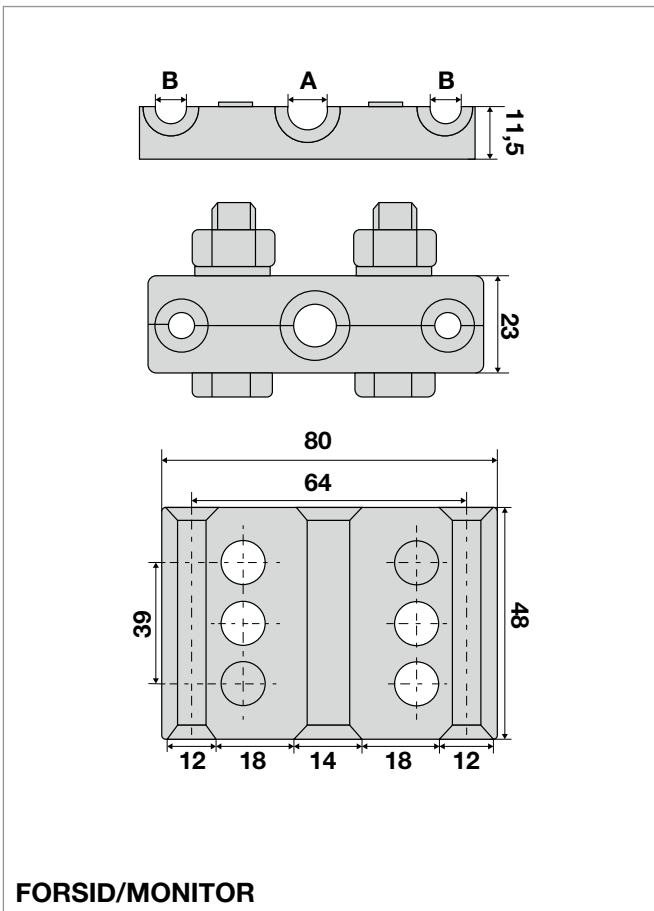

Codice / Code	Descrizione	Combinazione Diametri	A	B
12097	Pattino fune FORSID/MONITOR	1 fune Ø8 - 2 funi Ø 6	8,5	6,5
12097/02	Pattino fune FORSID/MONITOR	1 fune Ø10 - 2 funi Ø 8	10,5	8,5

Codice	Descrizione	Codice	Descrizione	Combinazione Diametri	A	B
12100/01	Pattino fune Nylon	12101/01	Pattino fune Desmopan	1 fune Ø 8 - 2 funi Ø 6	8,5	6,5
12100A/02	Pattino fune Nylon	12101A/02	Pattino fune Desmopan	1 fune Ø 9 - 2 funi Ø 7	9,5	7,5
12100B/03	Pattino fune Nylon	12101B/03	Pattino fune Desmopan	1 fune Ø 10 - 2 funi Ø 8	10,5	8,5
12100C/04	Pattino fune Nylon	12101C/04	Pattino fune Desmopan	1 fune Ø 11 - 2 funi Ø 8	11,5	8,5

PATTINI FUNE BASSETTI GUIDE SHOES FOR ROPES BASSETTI

19

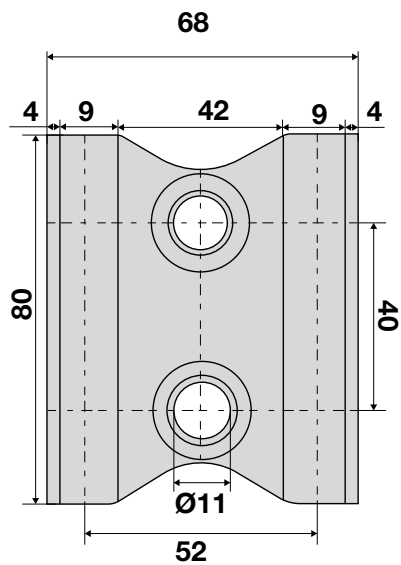
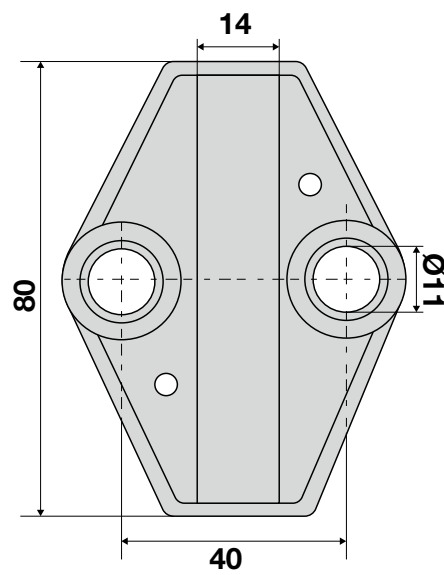

Codice / Code	Descrizione
12110	Pattino a 1 fune BASSETTI (codice per 1 coppia)
12110/1	Pattino per bordiglione a 2 funi BASSETTI (codice per 1 coppia)

PATTINI CONTRAPESO SAFOV - SCHINDLER - SABIEM
GUIDE SHOES C/WEIGHT SAFOV - SCHINDLER - SABIEM

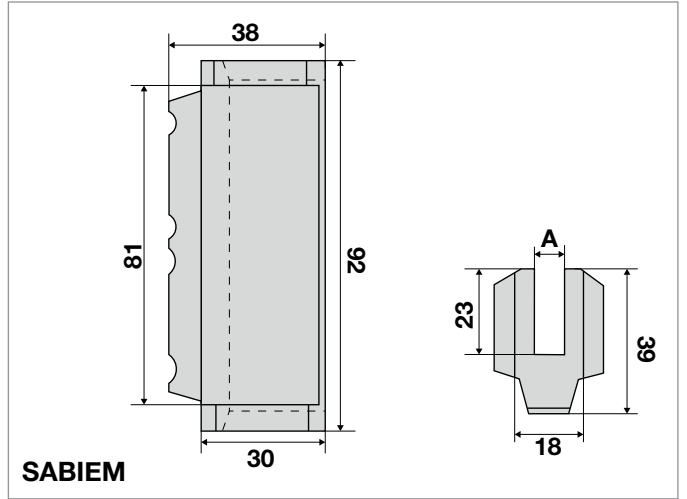
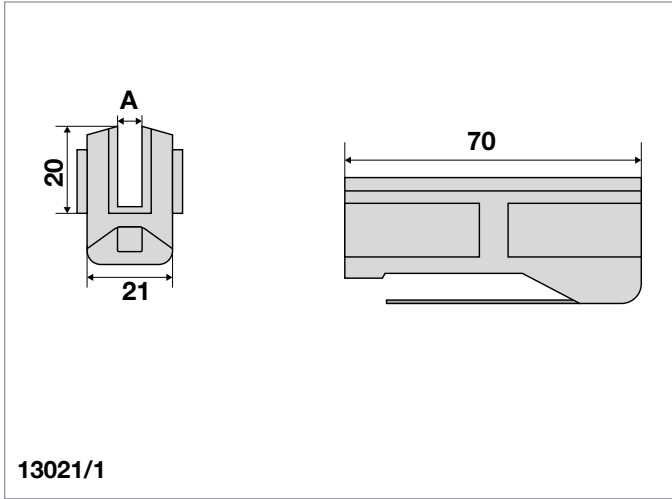
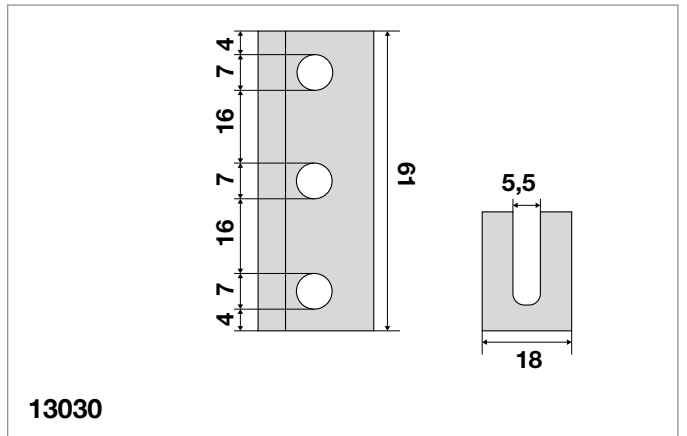
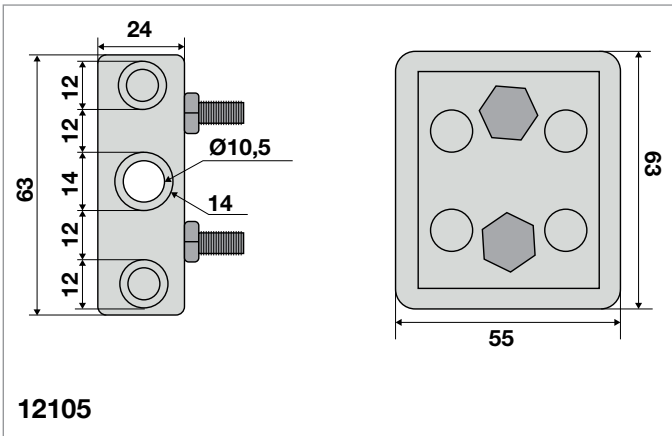

Codice / Code	Descrizione
12105	Pattino contrappeso SAFOV
13030	Pattino contrappeso rigido SCHINDLER

Codice / Code	Descrizione	Guida	A
13021/1	Pattino contrappeso con lamella SABIEM	T50	6,5

Codice	Descrizione	Guida	A	Codice	Descrizione	Guida	A
13022/5	Pattino contrappeso SABIEM	T50	6,5	13022/3	Pattino contrappeso SABIEM	T90	10,5
13022/1	Pattino contrappeso SABIEM	T60	7,5	13022/4	Pattino contrappeso SABIEM	T12	12,5
13022	Pattino contrappeso SABIEM	T70	8,5				

PATTINI CONTRAPESO FIAM - STANDARD

GUIDE SHOES C/WEIGHT FIAM - STANDARD

19

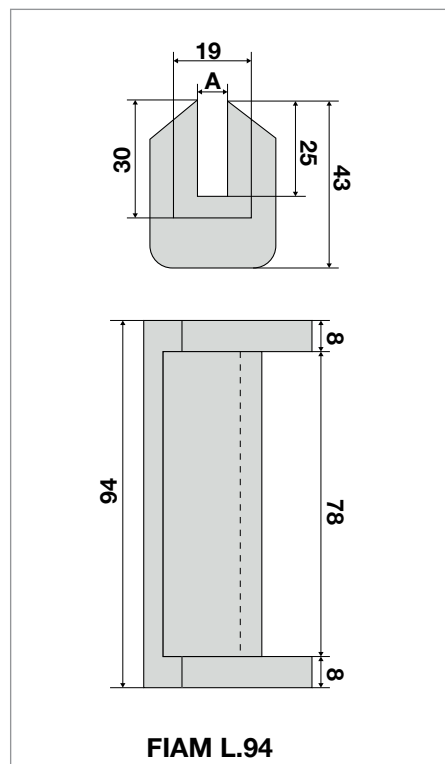
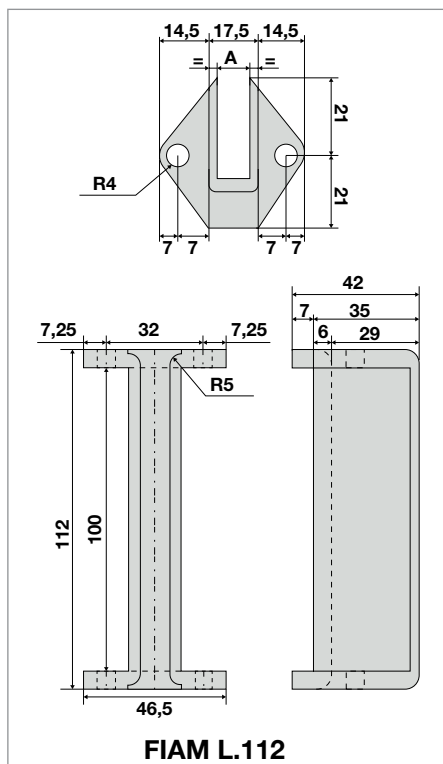
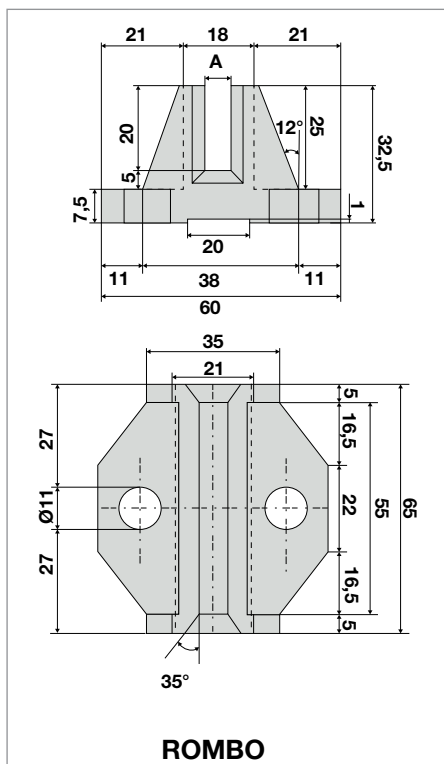

Codice	Descrizione	Guida	A	Codice	Descrizione	Guida	A
13001	Pattino c/peso ROMBO Desmopan	T40	5,5	13004	Pattino c/peso ROMBO Nylon	T50	6,5
13002	Pattino c/peso ROMBO Nylon	T40	5,5	13005	Pattino c/peso ROMBO Nylon	T60	7,5
13003	Pattino c/peso ROMBO Desmopan	T50	6,5	13006	Pattino c/peso ROMBO Nylon	T70	8,5

Codice / Code	Descrizione	Guida	A
13018/2	Pattino contrappeso FIAM L.112	T50	6,5
13018/3	Pattino contrappeso FIAM L.112	T60	7,5
13018/1	Pattino contrappeso FIAM L.112	T70	8,5
13018	Pattino contrappeso FIAM L.112	T80	9,5
13018/4	Pattino contrappeso FIAM L.112	T90	10,5

Codice / Code	Descrizione	Guida	A
13019/1	Pattino contrappeso FIAM L.94	T50	6,5
13019	Pattino contrappeso FIAM L.94	T70	8,5

PATTINI CONTRAPPEO STANDARD GUIDE SHOES C/WEIGHT STANDARD



Pattino Rombo



Pattino a squadra



13016

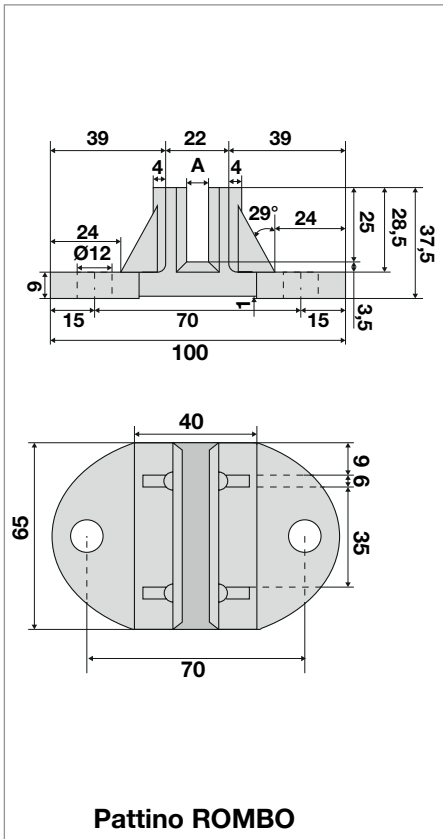

Pattino ROMBO

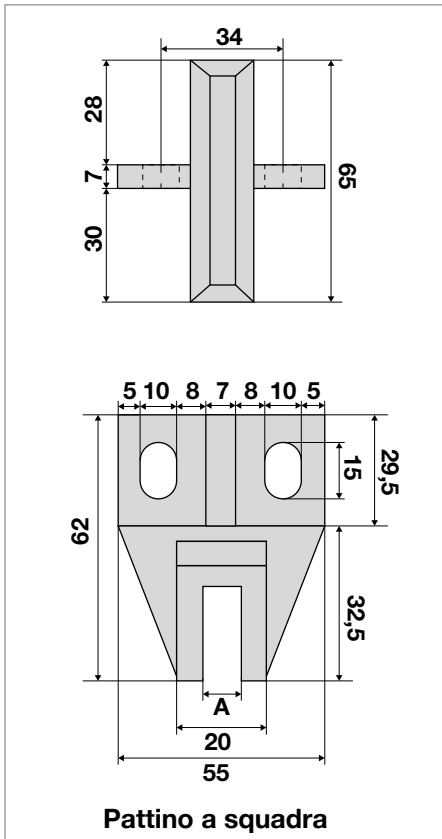

Pattino a squadra

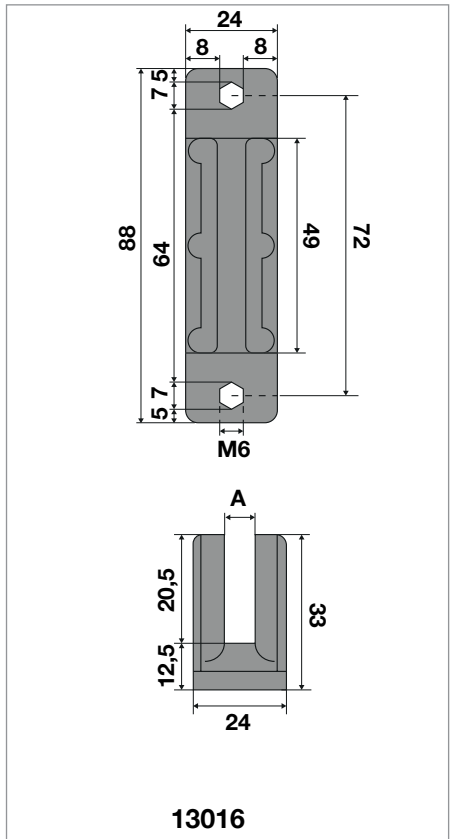

13016

Codice / Code	Descrizione	Guida	A
13008	Pattino contrappeso ROMBO largo Nylon	T40	5,5
13009	Pattino contrappeso ROMBO largo Nylon	T50	6,5
13010	Pattino contrappeso ROMBO largo Nylon	T60	7,5
13011	Pattino contrappeso ROMBO largo Nylon	T70	8,5
13012	Pattino contrappeso ROMBO largo Nylon	T100	10,5
Codice / Code	Descrizione	Guida	A
13013	Pattino contrappeso a squadra Nylon	T40	5,5
13014	Pattino contrappeso a squadra Nylon	T50	6,5
13015	Pattino contrappeso a squadra Nylon	T60	7,5
Codice / Code	Descrizione	Guida	A
13016	Pattino contrappeso con bussole	T50	6,5

PATTINI CONTRAPPESO DELTA - STANDARD GUIDE SHOES C/WEIGHT DELTA - STANDARD

19

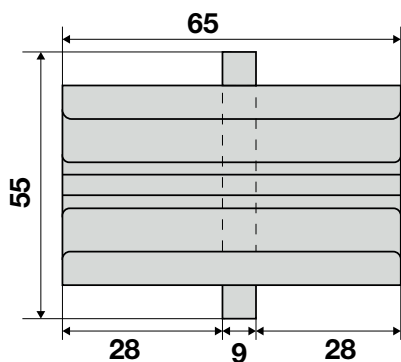

13025

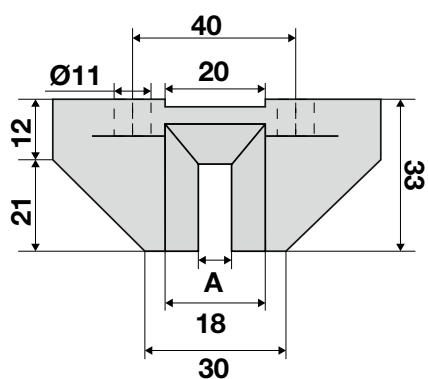
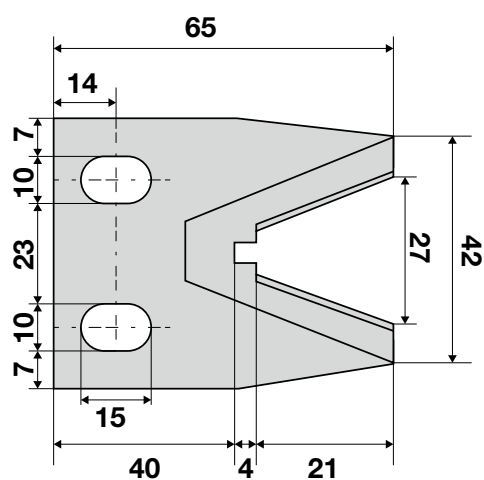

PATTINO CONTRAPPESO QUADRO

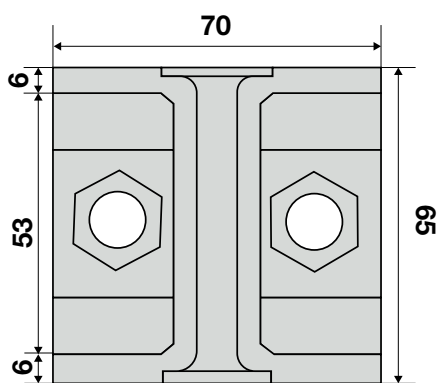

Codice / Code	Descrizione	Guida	A
13025	Pattino contrappeso DELTA		
13032/1	Pattino contrappeso quadro	T40	5,5
13032	Pattino contrappeso quadro	T50	6,5
13033	Pattino contrappeso quadro	T60	7,5

PATTINI PER PORTE SCORREVOLI SCHINDLER - FALCONI - BASSETTI
GUIDE SHOES FOR SLIDING DOOR SCHINDLER - FALCONI - BASSETTI



12203



12204



12207



12207/1

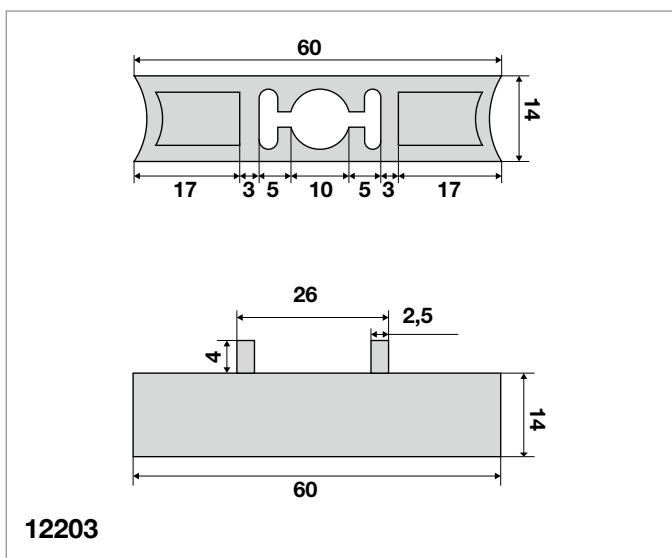

12203

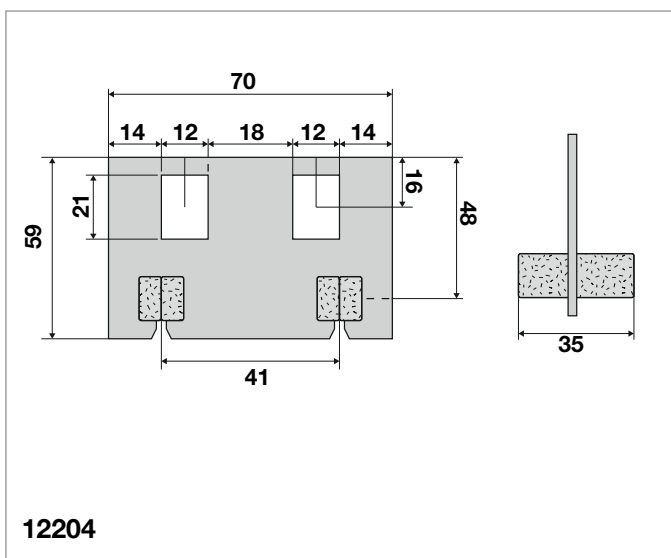

12204

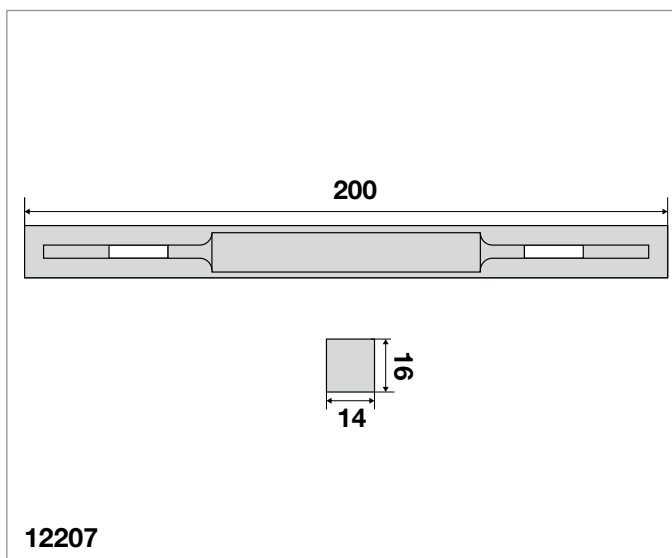

12207

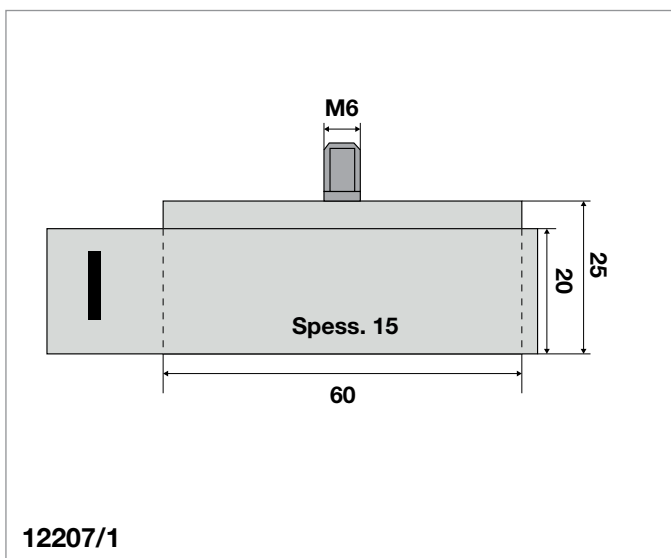

12207/1

Codice / Code	Descrizione
12203	Pattino soglia SCHINDLER
12204	Pattino soglia SCHINDLER con feltrini per porta automatica
12207	Pattino soglia FALCONI P-1352 16 x 200
12207/1	Pattino soglia BASSETTI per porta automatica in feltro

PATTINI PER PORTE SCORREVOLI FIAM - FORSID/MONITOR GUIDE SHOES FOR SLIDING DOOR FIAM - FORSID/MONITOR

19

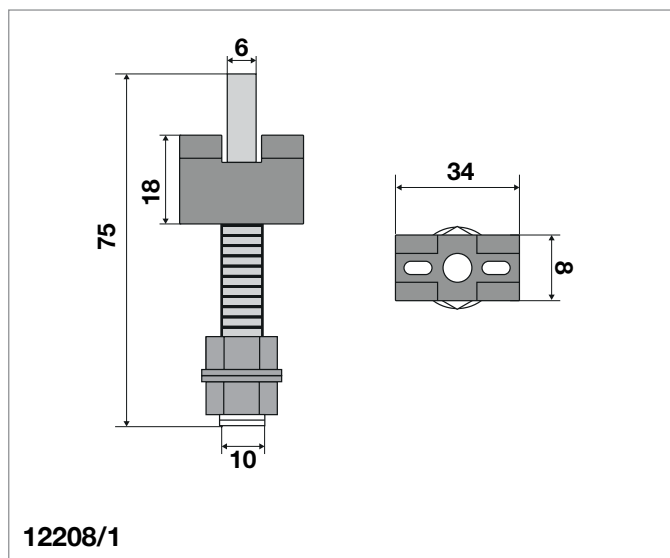
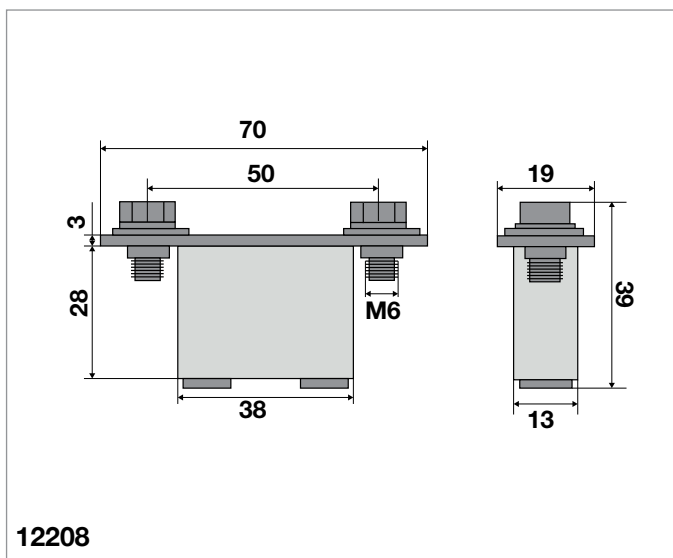
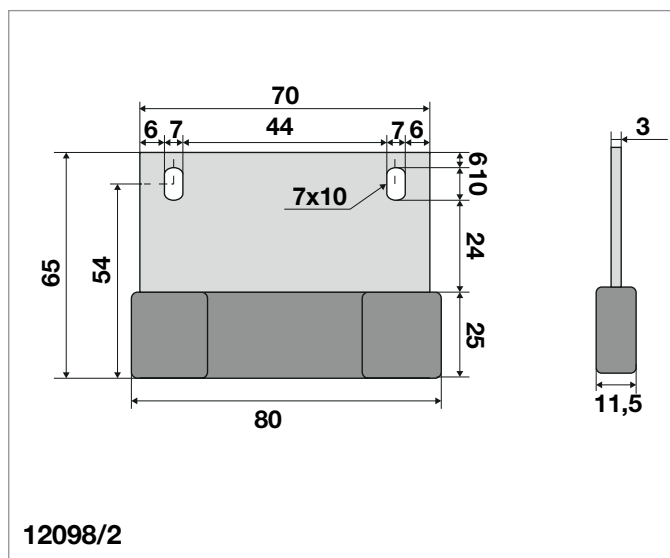
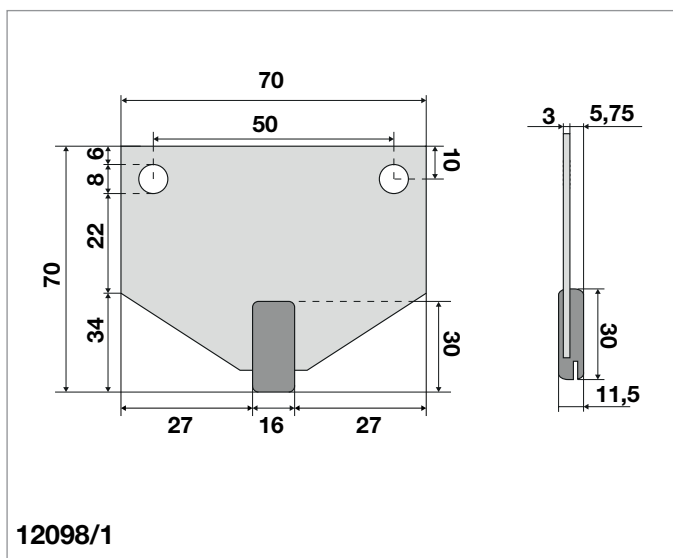

Codice / Code	Descrizione
12098/1	Pattino soglia FIAM per porte automatiche
12098/2	Pattino soglia FIAM per porta automatica tipo S
12208	Pattino soglia FORSID/MONITOR per porta automatica tipo ZIP
12208/1	Pattino soglia FORSID/MONITOR per porta automatica tipo 92VF

PATTINI PER PORTE SCORREVOLI

GUIDE SHOES FOR SLIDING DOOR

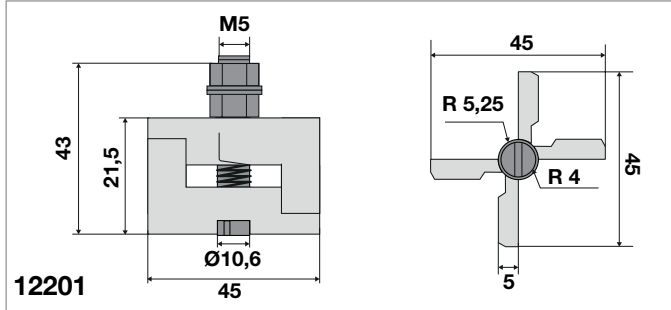
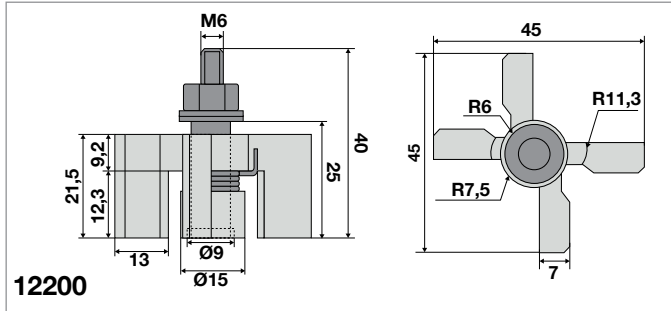
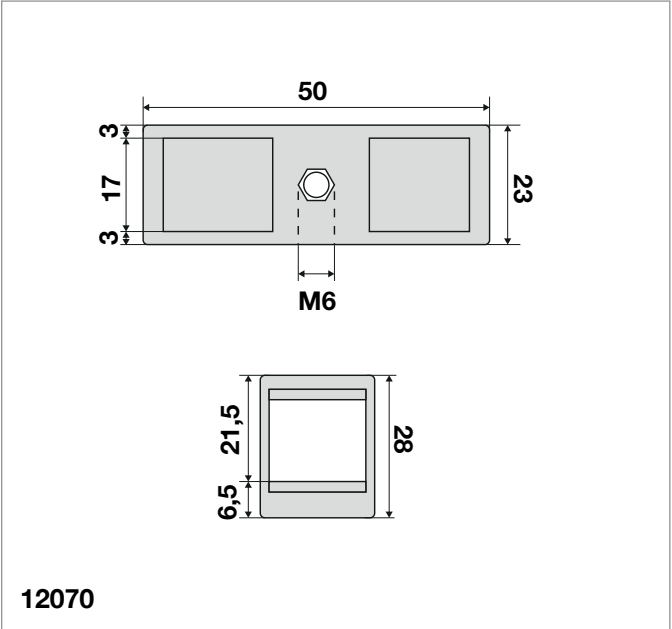
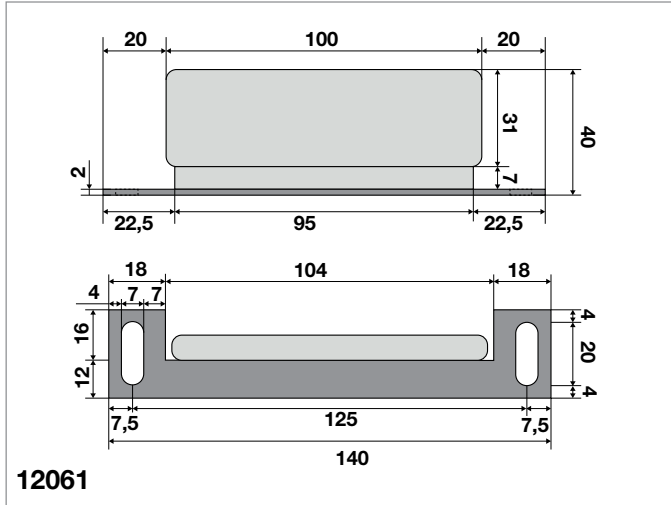
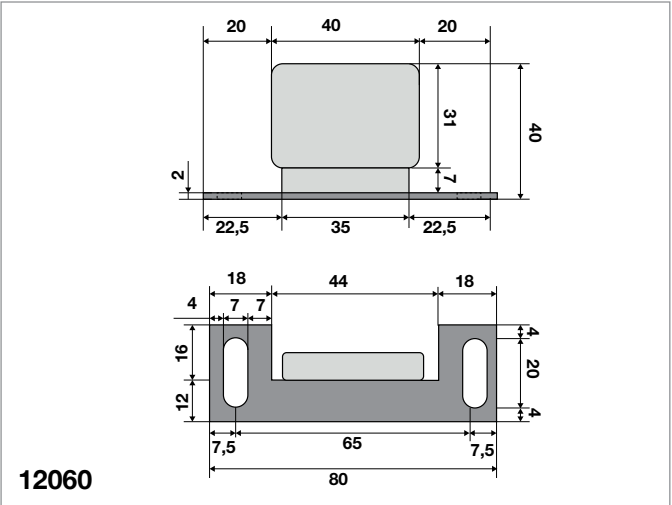
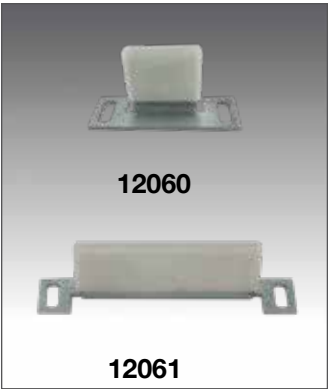

Codice / Code	Descrizione
12060	Pattino per portine a squadra corto
12061	Pattino per portine a squadra lungo
12070	Pattino per cancelli 50 x 23 x 28 M6
12200	Pattino a farfalla per soglia cava 14 e 16 mm
12201	Pattino a farfalla per soglia cava 12 mm

PATTINI SOGLIA OTIS SILL GUIDE SHOES OTIS

19

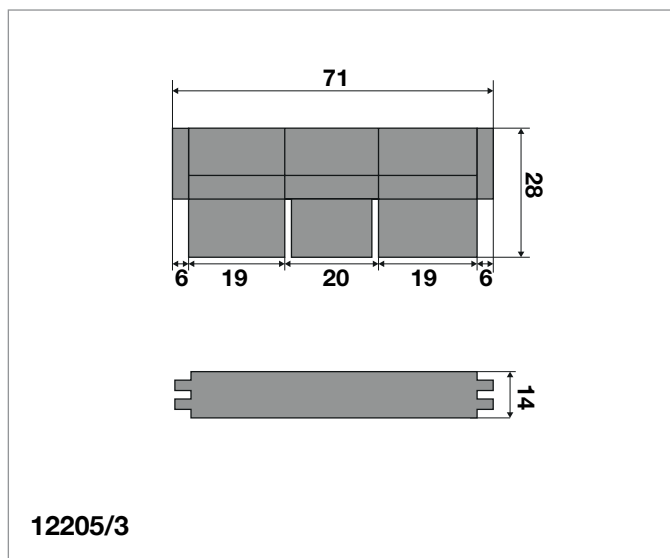
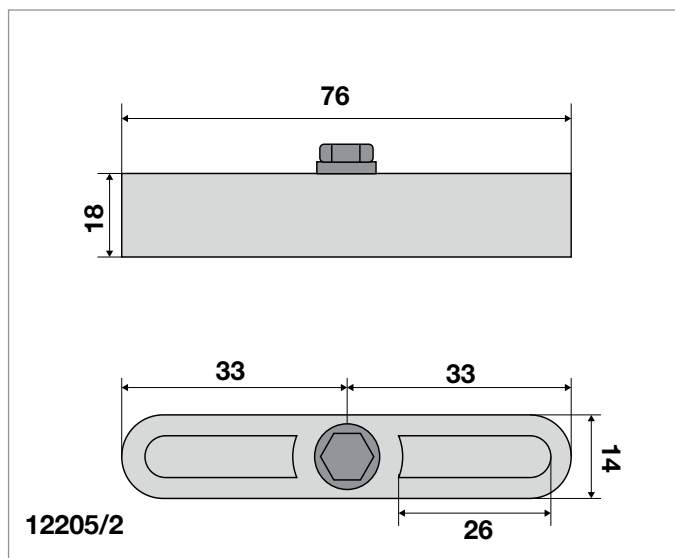
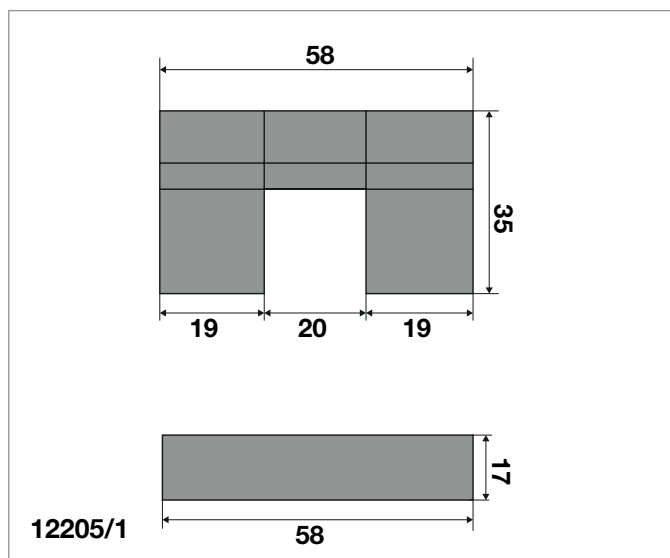
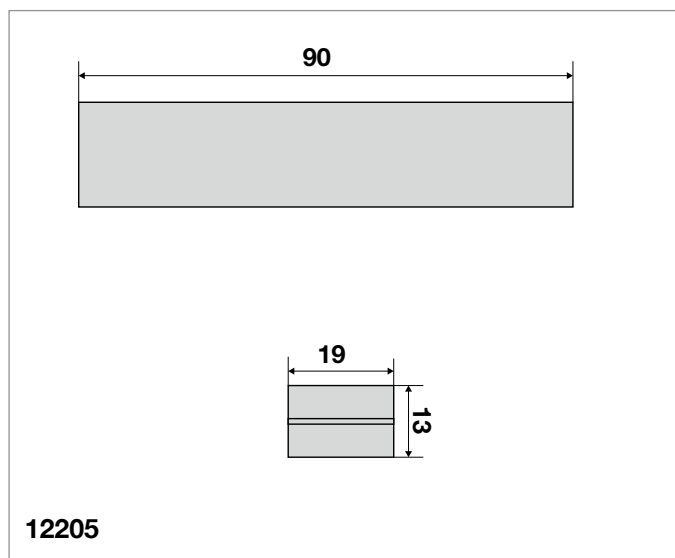
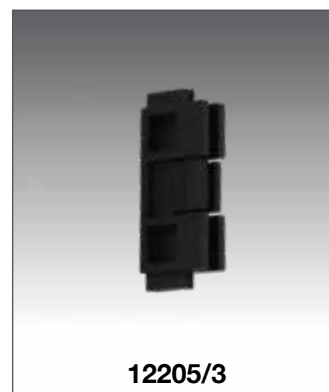
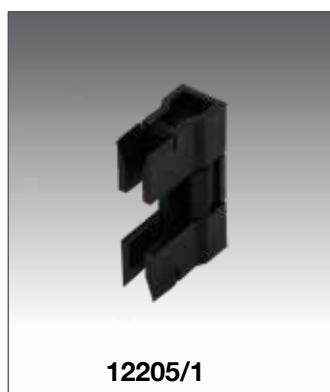

Codice / Code	Descrizione
12205	Pattino soglia OTIS M0 251 AWI
12205/1	Pattino LM OTIS misure 58 x 35 x 17 mm
12205/2	Pattino OTIS 9779 Mod. 80 misure 76 x 18 x 14 mm
12205/3	Pattino ORLY OTIS misure 58 x 28 x 13 mm

PATTINO PORTE A GHIGLIOTTINA OTIS TIEFFE
GIB GUILLOTINE DOORS OTIS TIEFFE

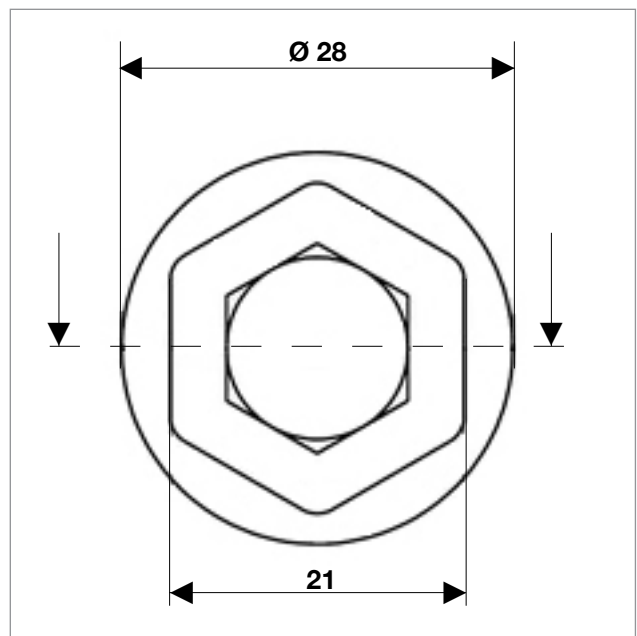
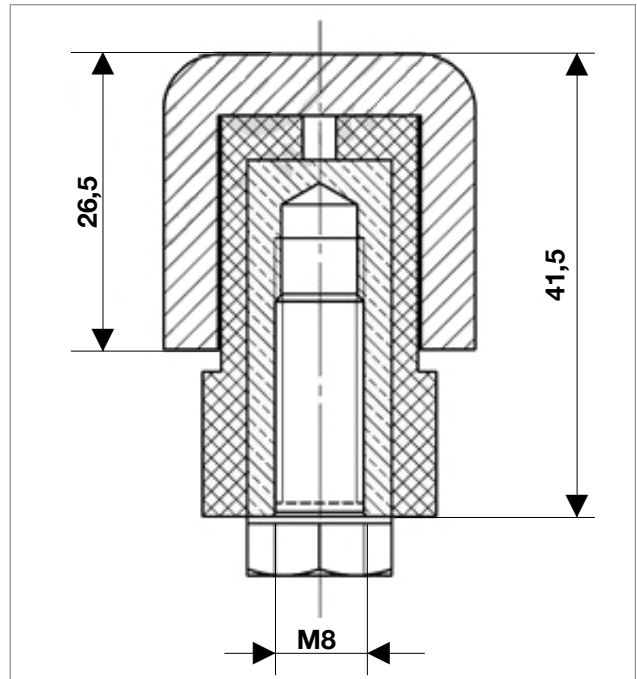

Codice / Code	Descrizione	Guida	A
12205/6	Pattino porta a ghigliottina OTIS TIEFFE	Profilo a "U"	30

RONDELLE PORTA PATTINI RUBBER WASHER FOR GUIDE SHOES

19

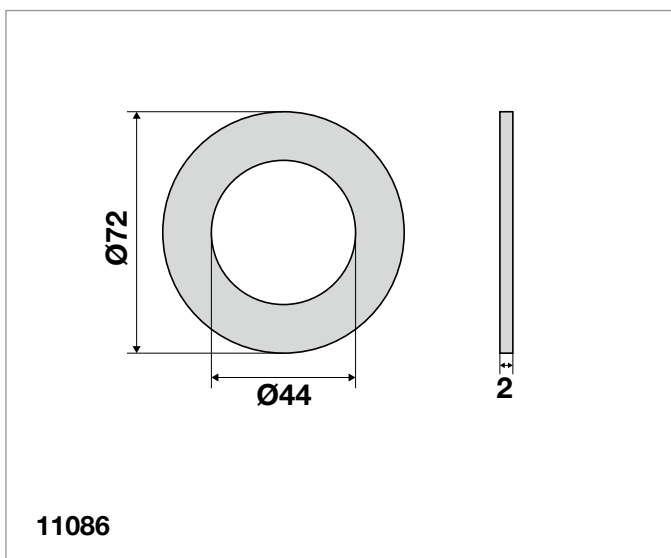
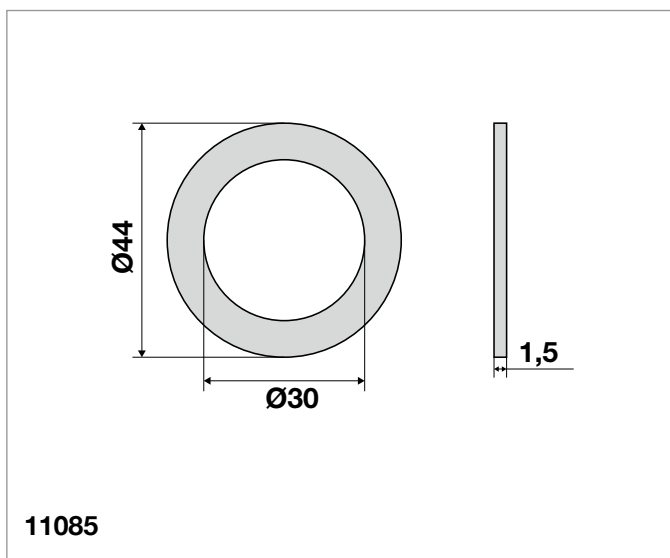
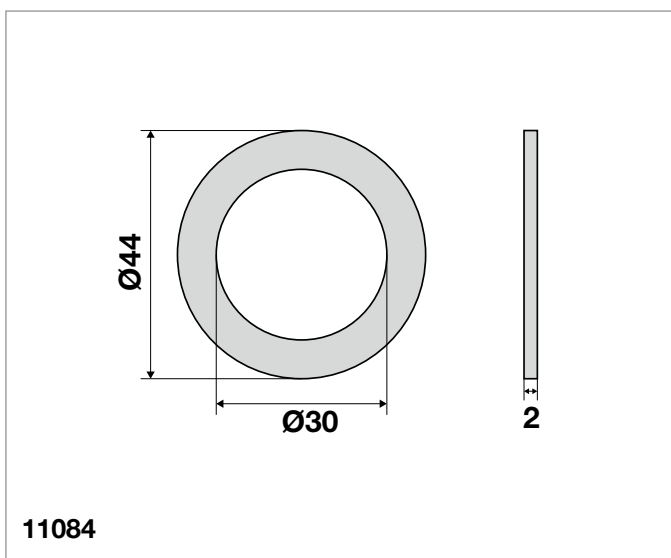
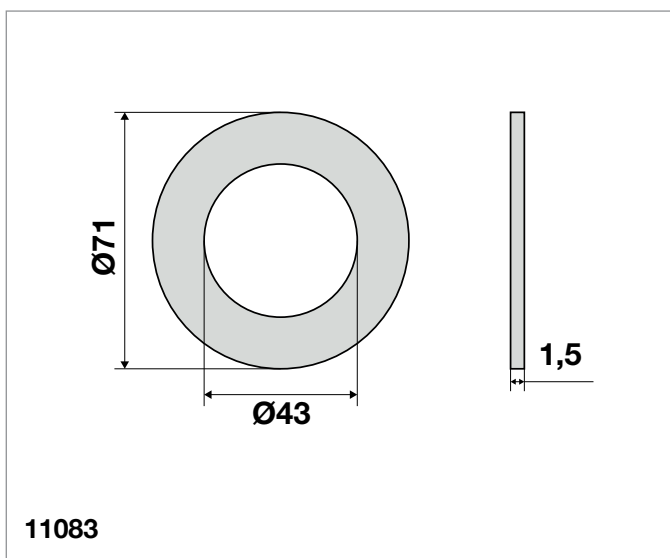
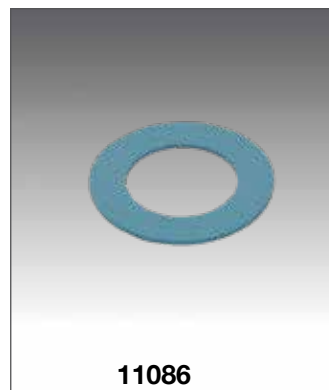
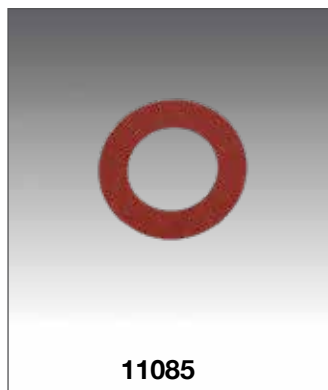

Codice / Code	Descrizione
11083	Rondella grande rigida in fibra D.I.43 D.E.71 Sp. 1,5
11084	Rondella piccola morbida FIAM D.I.30 D.E.44 Sp. 2 esente amianto
11085	Rondella piccola rigida FIAM in fibra D.I.30 D.E.44 Sp. 1,5
11086	Rondella grande morbida D.I.44 D.E.72 Sp. 2 esente amianto

PROFILI IN GOMMA PER BATTUTA PORTE SCORREVOLI E CANCELLI A GHIGLIOTTINA
STOP RUBBER PROFILES FOR SLIDING DOORS AND GUILLOTINE GATES

FIAM - Standard 20.2

Note: I componenti sul catalogo con riportata una specifica marca di ascensore sono utilizzati abitualmente solo da questa marca. I particolari senza marca sono utilizzati da più marche di ascensori.

Note: *The components in the catalogue with a specific lift brand are usually used only by the brand. Unbranded parts are used by multiple lift brands.*

PROFILI IN GOMMA PER BATTUTA PORTINE SCORREVOLI E CANCELLI A GHIGLIOTTINA
STOP RUBBER PROFILES FOR SLIDING DOORS AND GUILLOTINE GATES

20

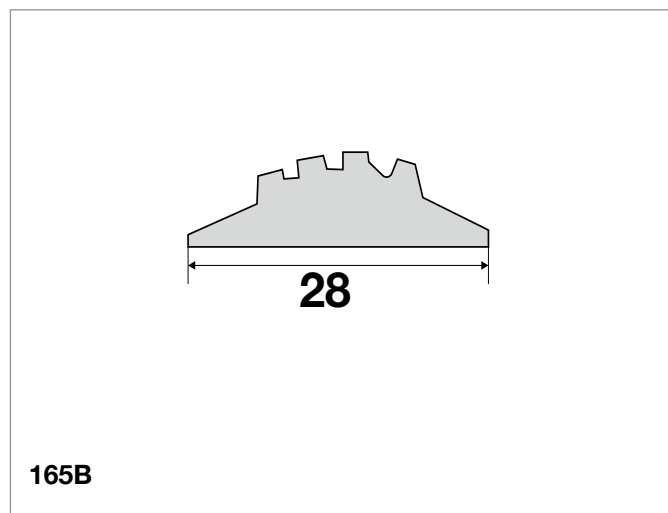
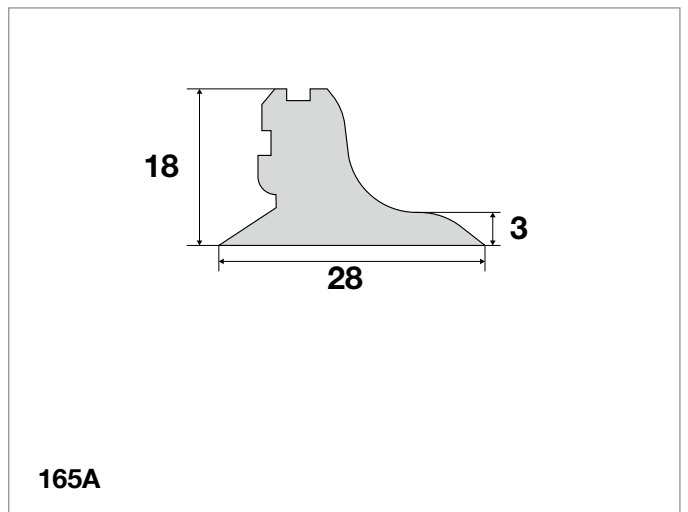
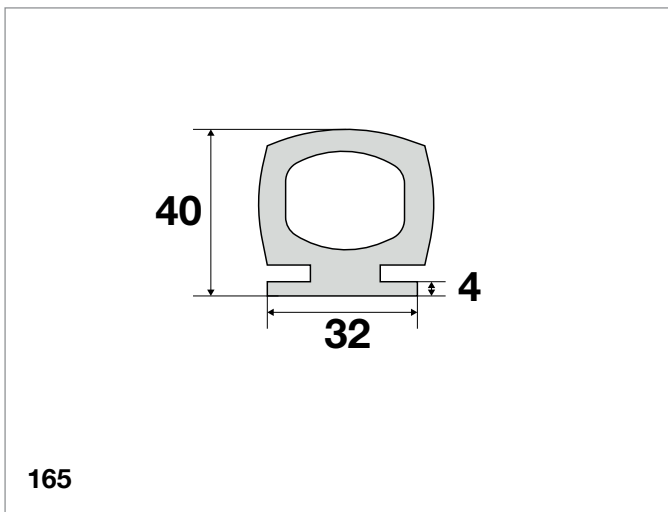

Codice / Code	Descrizione
165	Gomma di battuta cancelli a ghigliottina FIAM (spezzone da 2 mt.)
165A	Profilo di battuta in gomma per porte automatiche tipo vecchio FIAM (spezzone da 2 mt.)
165B	Profilo di battuta in gomma per porte automatiche (spezzone da 2 mt.)

CAVO PIATTO E ACCESSORI
FLAT CABLES AND ACCESSORIES

Cavo piatto IMQ per ascensori	21.2
<i>Flat cable IMQ for lifts</i>	
Ferma cavi	21.4
<i>Terminal block</i>	
Morsettiere	21.3
<i>Terminal board</i>	
Zeppa fissacavo	21.5
<i>Wedge-lock cable clip</i>	

Note: I componenti sul catalogo con riportata una specifica marca di ascensore sono utilizzati abitualmente solo da questa marca. I particolari senza marca sono utilizzati da più marche di ascensori.

Note: The components in the catalogue with a specific lift brand are usually used only by the brand. Unbranded parts are used by multiple lift brands.

CAVO PIATTO FLESSIBILE PER ASCENSORI IMQ FLEXIBLE FLAT CABLE FOR IMQ LIFTS

21



CAVO PIATTO FLESSIBILE PER ASCENSORI DI QUALITÀ - IMQ -

Codice / Code	N° Conduttori 1 mmq
C3	3 x 1 mmq
C6	6 x 1 mmq
C9	9 x 1 mmq
C12	12 x 1 mmq
C16	16 x 1 mmq
C20	20 x 1 mmq

Codice / Code	N° Conduttori 0,75 mmq
C3/1	3 x 0,75 mmq
C6/1	6 x 0,75 mmq
C9/1	9 x 0,75 mmq
C12/1	12 x 0,75 mmq
C16/1	16 x 0,75 mmq
C20/1	20 x 0,75 mmq

Vendita con taglio in misura o vendita in bobina da 500 metri

MORSETTIERE TERMINAL BOARD



3950

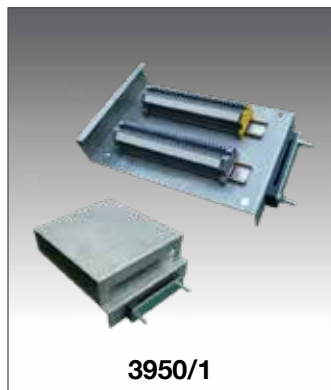

3950/1



3951

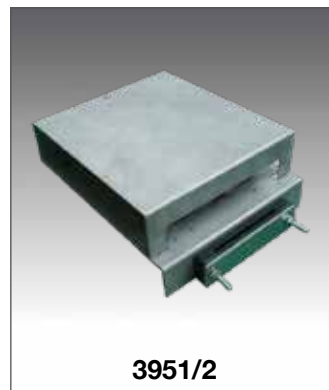

3951/2

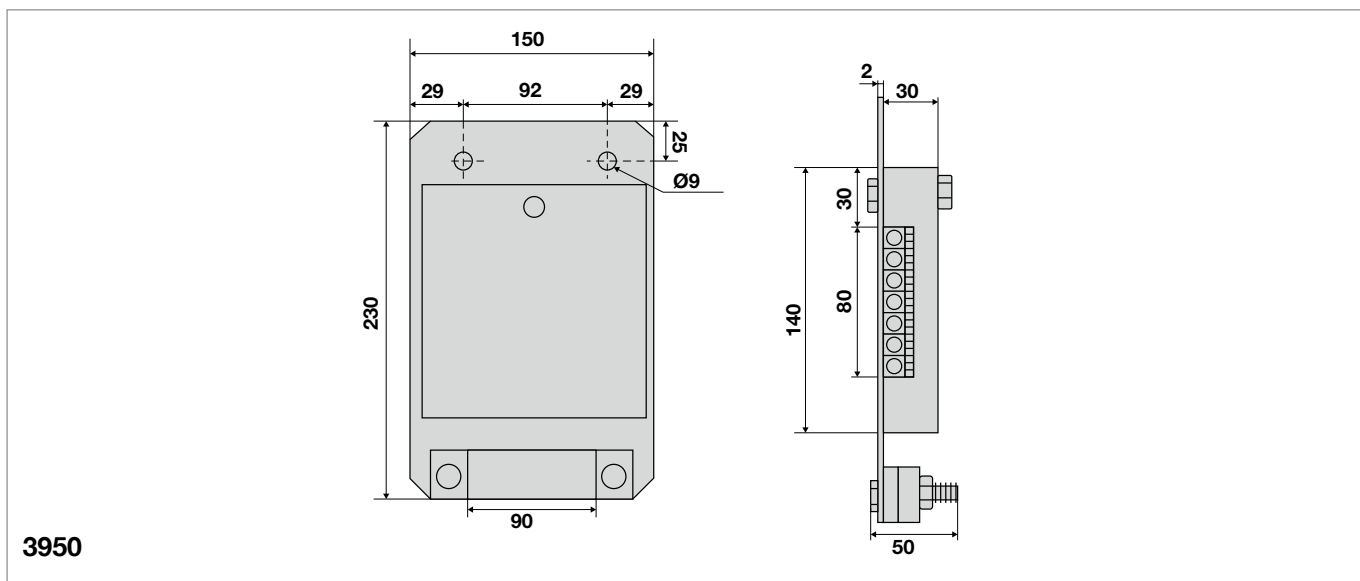

3950

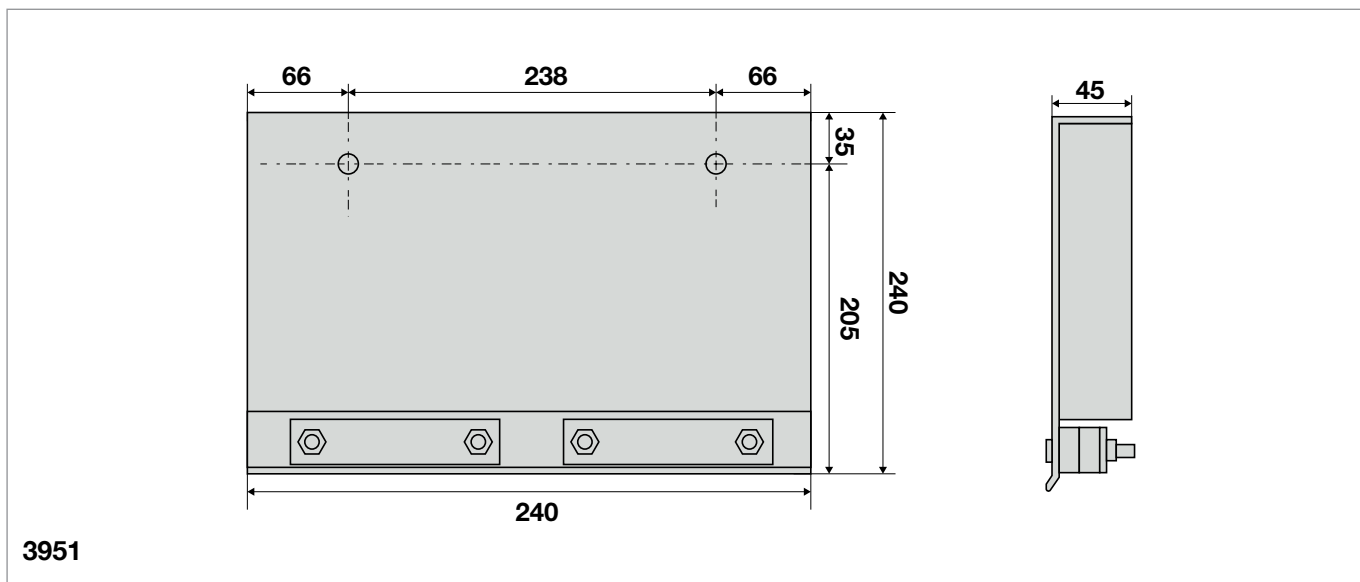

3951

Codice / Code	Descrizione
3950	Morsettiera a 60 morsetti
3950/1	Morsettiera a 60 morsetti a norme EN.50.045 dimensioni esterni: 205 x 300x 55 mm
3951	Morsettiera a 36 morsetti
3951/2	Morsettiera a 40 morsetti a norme EN.50.045 dimensioni esterni: 205 x 250 x 55 mm

FERMO CAVO TERMINAL BLOCK

21



3952



3954

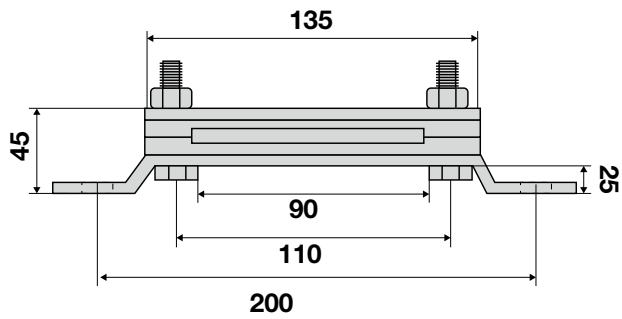

3952

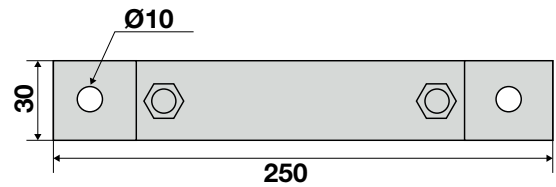

3954

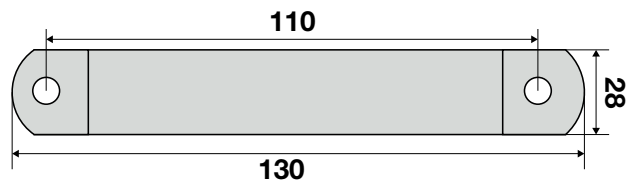

Codice / Code	Descrizione
3952	Fermo cavo a muro
3954	Gomma passacavi per cod. 3952

ZEPPA FISSACAVO WEDGE-LOCK CABLE CLIP



3953



3953/1

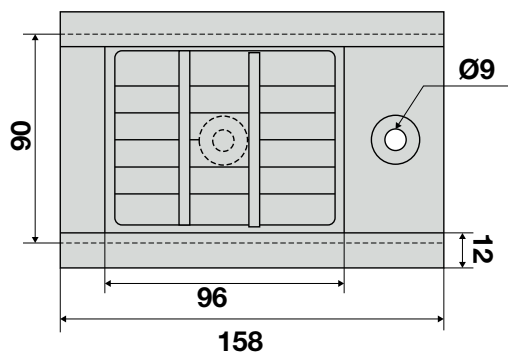

3953

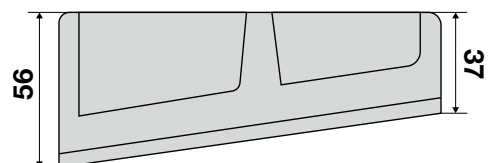

21

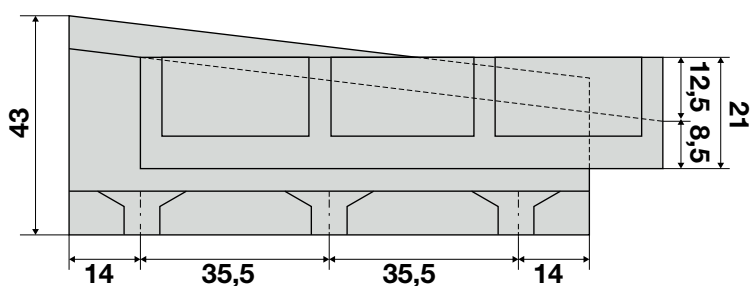

3953/1

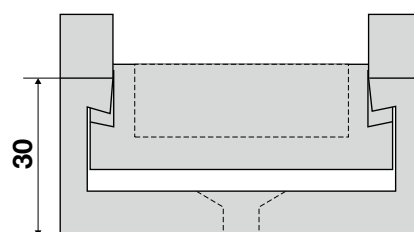

Codice / Code	Descrizione
3953	Zeppa fissacavo Nylon
3953/1	Zeppa fissacavo BASSETTI Dim. 70x100

NOTE

FRIZIONI
CLUTCHES

Frizione operatore FIAM tipo S2PO	22.2
<i>Clutch for operator FIAM type S2PO</i>	
Ruota di frizione operatore FIAM tipo S.....	22.2
<i>Roller for clutch operator FIAM type S</i>	
Kit sostituzione frizione FIAM A/2PO.....	22.2
<i>Replacement kit clutch FIAM A/2PO</i>	

Note: I componenti sul catalogo con riportata una specifica marca di ascensore sono utilizzati abitualmente solo da questa marca. I particolari senza marca sono utilizzati da più marche di ascensori.

Note: *The components in the catalogue with a specific lift brand are usually used only by the brand. Unbranded parts are used by multiple lift brands.*

FRIZIONI CLUTCHES



22

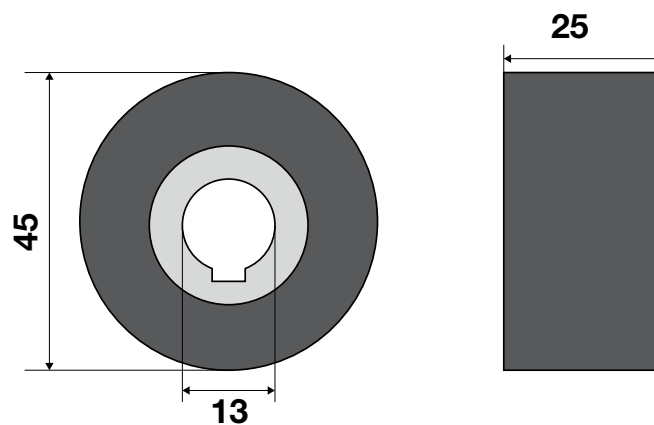
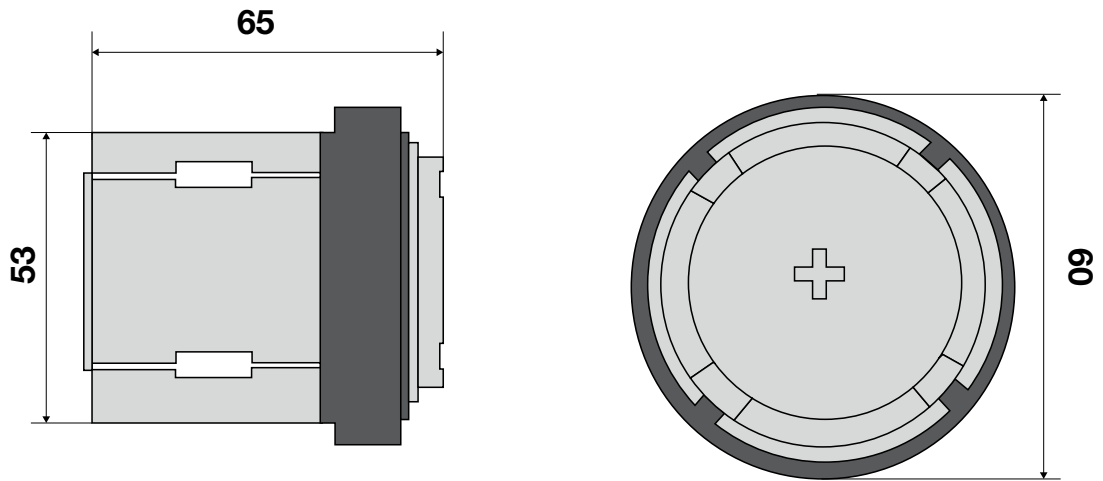

Codice / Code	Descrizione
4550	Frizione per operatore di cabina FIAM tipo S/2PO
4551	Ruota di frizione per guarnizione FIAM tipo S
4552FI	Kit sostituzione frizione FIAM A/2PO

LAMPADINE E PLAFONIERE PER ASCENSORI
LAMPS AND CEILING LIGHT FOR LIFT

LAMPADINE
LAMPS

SCHINDLER - OTIS - SABIEM - FALCONI - SAFOV - BASSETTI - IGV FORSID - CEAM da 23.2 a 23.22

N.B: Si prega di comunicare dimensioni - tipologia (esempio: Siluro), Volt e Watt.
Disponibili su ordinazione anche altri modelli fuori catalogo

Att.n: *Please inform us the dimension - type - Volt - Watt.*
The other models that are not included in catalogue are available on demand.

PLAFONIERE
CEILING LIGHT

Plafoniera BASSETTI 23.23

BASSETTI ceiling light

Plafoniera OTIS 23.23

OTIS ceiling light

Plafoniera SCHINDLER 23.23

SCHINDLER ceiling light

Plafoniere a LED 23.23

Ceiling light in LED

LAMPADE PORTATILI
PORTABLE LAMPS

Lampada portatile 220 V tipo "officina" 23.24

Portable lamp 220 V type "workshop"

Note: I componenti sul catalogo con riportata una specifica marca di ascensore sono utilizzati abitualmente solo da questa marca. I particolari senza marca sono utilizzati da più marche di ascensori.

Note: *The components in the catalogue with a specific lift brand are usually used only by the brand. Unbranded parts are used by multiple lift brands.*

LAMPADINE LAMPS

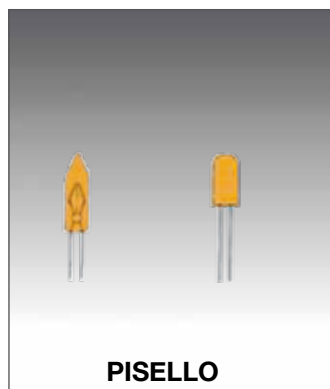
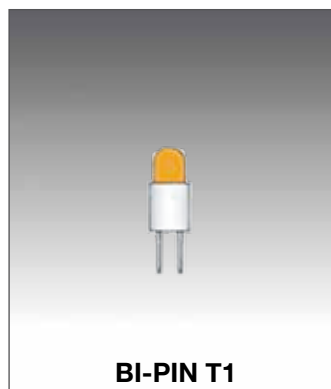

BI-PIN T1

Codice / Code	Passo	Dimensioni	V	mA	MSCP	Filam
BP1.27005	1,27	3,17 x 9,15	5	60	.050	C-2R
BP1.27.012	1,27	3,17 x 9,15	12	60	.150	C-2V
BP2.54.005	2,54	3,17 x 9,65	5	60	.050	C-2R
BP2.54.006	2,54	3,17 x 9,65	6	115	.150	C-2R
BP2.54.012	2,54	3,17 x 9,65	12	60	.150	C-2V
BP2.54.018	2,54	3,17 x 9,65	18	26	.150	C-2F
BP2.54.024	2,54	3,17 x 9,65	24	24	.150	CC-2F
BP2.54.028	2,54	3,17 x 9,65	28	24	.150	CC-2F
BP2.54.036	2,54	3,17 x 9,65	36	20	.150	CC-2F
BP3.17.005	3,17	3,17 x 10	5	60	.050	C-2R
BP3.17.012	3,17	3,17 x 10	12	60	.150	C-2V
BP3.17.028	3,17	3,17 x 10	28	24	.150	CC-2F

PISELLO

Codice / Code	Tipo	Dimensioni	V	mA	MSCP	Filam
P03.06.005	T1	3,2 x 6,35	5	115	.150	C-2R
P03.06.006	T1	3,2 x 6,35	6	70	.120	C-2R
P03.06.012	T1	3,2 x 6,35	12	60	.150	CC-2V
P03.06.028	T1	3,2 x 6,35	28	24	.150	C-2F

Codice / Code	Tipo	Dimensioni	V	mA	MSCP	Filam
P05.16.003	Stagnati	5 x 16	3,5	100	senza cc	C-2R
P05.16.006	Stagnati	5 x 16	6	120	senza cc	C-2R
P05.16.012	Stagnati	5 x 16	12	100	senza cc	C-2V
P05.16.018	Stagnati	5 x 16	18	80	senza cc	CC-2V
P05.16.024	Stagnati	5 x 16	24	50	senza cc	CC-2F

LAMPADINE LAMPS

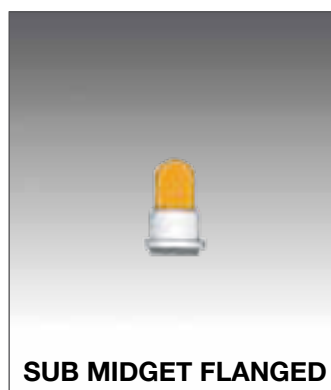

BAIONETTA 7 X 20

Codice / Code	Base	Dimensioni	V	W-mA	Filam
B07.20.006A	Ba7s	7 x 20	6	0,6	C-2R
B07.20.006C	Ba7s	7 x 20	6	1,2	C-2R
B07.20.006F	Ba7s	7 x 20	6	2	C-2R
B07.20.012C	Ba7s	7 x 20	12	1,2	C-2V
B07.20.012F	Ba7s	7 x 20	12	2	C-2V
B07.20.024A	Ba7s	7 x 20	24	0,6	C-2F
B07.20.024C	Ba7s	7 x 20	24	1,2	C-2F
B07.20.024D	Ba7s	7 x 20	24	1,5	C-2F
B07.20.024F	Ba7s	7 x 20	24	2	C-2F
B07.20.024I	Ba7s	7 x 20	24	3	C-2F
B07.20.028M	Ba7s	7 x 20	28	0,55-20mA	C-2F
B07.20.028D	Ba7s	7 x 20	28	1,5	C-2F
B07.20.028R	Ba7s	7 x 20	28	1,7-60mA	C-2F
B07.20.030D	Ba7s	7 x 20	30	1,5	C-2F
B07.20.030F	Ba7s	7 x 20	30	2	C-2F
B07.20.036E	Ba7s	7 x 20	36	1,8	C-2F
B07.20.048C	Ba7s	7 x 20	48	1,2	CC-2F
B07.20.060C	Ba7s	7 x 20	60	1,2	CC-2F

BAIONETTA 7 X 23

Codice / Code	Base	Dimensioni	V	W-mA	Filam
BNO.23.085	Ba7s	7 x 23	85	neon	elettrodi
BNO.23.110	Ba7s	7 x 23	110	neon	elettrodi
BNO.23.220	Ba7s	7 x 23	220	neon	elettrodi

SUB MIDGET FLANGED

Codice / Code	BASE	Dimensioni	V	mA	MSCP	Filam
F03.09.005	T1	3,2 x 9,5	5	60	.030	C-2R
F03.09.012	T1	3,2 x 9,5	12	60	.150	C-2V
F03.09.028	T1	3,2 x 9,5	28	24	.150	CC-2F

LAMPADINE LAMPS

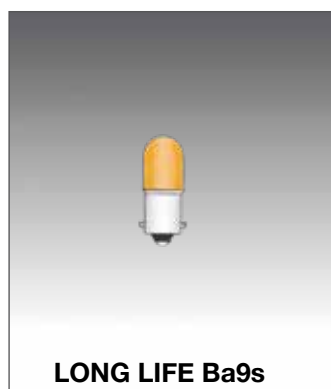

LONG LIFE Ba9s 10 x 28

Codice / Code	BASE	Dimensioni	V	W	Filamento
B50.28.012	Ba9s	10 x 28	12	2	C-2F
B50.28.024	Ba9s	10 x 28	24	2	C-2F
B50.28.030	Ba9s	10 x 28	30	2	C-3A
B50.28.048	Ba9s	10 x 28	48	2	CC-3A
B50.26.060	Ba9s	10 x 28	60	2	CC-3A
B50.28.130	Ba9s	10 x 28	130	2,6	CC-6A
B50.28.220F	Ba9s	10 x 28	220/230	2	CC-7A

BAIONETTA 10 X 28

Codice / Code	Base	Dimensioni	V	W	Filamento
B10.28.006A	Ba9s	10 x 28	6	0,6	C-2R
B10.28.006C	Ba9s	10 x 28	6	1,2	C-2R
B10.28.006F	Ba9s	10 x 28	6	2	C-2R
B10.28.006I	Ba9s	10 x 28	6	3	C-2R
B10.28.006V	Ba9s	10 x 28	6,3	250mA	C-2R
B10.28.007F	Ba9s	10 x 28	7	300mA	C-2R
B10.28.012A	Ba9s	10 x 28	12	0,6	C-2R
B10.28.012C	Ba9s	10 x 28	12	1,2	C-2V
B10.28.012D	Ba9s	10 x 28	12	1,5	C-2V
B10.28.012F	Ba9s	10 x 28	12	2	C-2V
B10.28.012I	Ba9s	10 x 28	12	3	C-2V
B10.28.014F	Ba9s	10 x 28	14	2	C-2V
B10.28.018E	Ba9s	10 x 28	18	1,8	C-2V
B10.28.024A	Ba9s	10 x 28	24	0,6	C-2V
B10.28.024C	Ba9s	10 x 28	24	1,2	C-2F
B10.28.024F	Ba9s	10 x 28	24	2	C-2F

LAMPADINE LAMPS

BAIONETTA 10 X 28

Codice / Code	Base	Dimensioni	V	W	Filamento
B10.28.024I	Ba9s	10 x 28	24	3	C-2F
B10.28.027F	Ba9s	10 x 28	24/30	2	C-2F
B10.28.028C	Ba9s	10 x 28	28	1,2	C-2F
B10.28.028F	Ba9s	10 x 28	28	2	C-2F
B10.28.028I	Ba9s	10 x 28	28	3	C-2F
B10.28.030C	Ba9s	10 x 28	30	1,2	C-2F
B10.28.030D	Ba9s	10 x 28	30	1,5	C-2F
B10.28.030F	Ba9s	10 x 28	30	2	C-2F
B10.28.030I	Ba9s	10 x 28	30	3	C-2F
B10.28.036E	Ba9s	10 x 28	36	1,8	C-2F
B10.28.036I	Ba9s	10 x 28	36	3	C-2F
B10.28.042F	Ba9s	10 x 28	42	2	C-2F
B10.28.048C	Ba9s	10 x 28	48	1,2	C-2F
B10.28.048F	Ba9s	10 x 28	48	2	C-2F
B10.28.048I	Ba9s	10 x 28	48	3	C-2F
B10.28.060C	Ba9s	10 x 28	60	1,2	C-2F
B10.28.060F	Ba9s	10 x 28	60	2	C-2F
B10.28.060G	Ba9s	10 x 28	60	2,4	C-2F
B10.28.060I	Ba9s	10 x 28	60	3	C-2F
B10.28.080F	Ba9s	10 x 28	80	2	C-3A
B10.28.120N	Ba9s	10 x 28	110/130	10mA	C-6A
B10.28.120O	Ba9s	10 x 28	110/130	20mA	C-5A
B10.28.110F	Ba9s	10 x 28	110	2	C-5A
B10.28.130F	Ba9s	10 x 28	130	2	C-5A
B10.28.130H	Ba9s	10 x 28	130	2,6	C-5A
B10.28.160F	Ba9s	10 x 28	160	2	C-5A
B10.28.160I	Ba9s	10 x 28	160	3	C-5A
B10.28.220I	Ba9s	10 x 28	220	3	C-7A
B10.28.230I	Ba9s	10 x 28	230	3	C-7A
B10.28.240I	Ba9s	10 x 28	240	3	C-7A
B10.28.240G	Ba9s	10 x 28	240	2,4	CC-7A
B10.28.250G	Ba9s	10 x 28	220/260	2/3	CC-7A
B10.28.260I	Ba9s	10 x 28	260	3	CC-7A
B10.28.380I	Ba9s	10 x 28	380	3	CC-7A

LAMPADINE LAMPS



LONG LIFE E10 10 X 28

Codice / Code	Base	Dimensioni	V	W	Filamento
E50.28.012	E10	10 x 28	12	2	C-2F
E50.28.024	E10	10 x 28	24	2	C-2F
E50.28.030	E10	10 x 28	30	2	C-3A
E50.28.048	E10	10 x 28	48	2	CC-3A
E50.26.060	E10	10 x 28	60	2	CC-3A
E50.28.130	E10	10 x 28	130	2,6	CC-6A

BAIONETTA 9 X 23

Codice / Code	Base	Dimensioni	V	W	Filamento
B09.23.006A	Ba9s	9 x 23	6	0,6	C-2R
B09.23.006C	Ba9s	9 x 23	6	1,2	C-2R
B09.23.006F	Ba9s	9 x 23	6	2	C-2R
B09.23.006I	Ba9s	9 x 23	6	3	C-2R
B09.23.006P	Ba9s	8,8 x 26	6	4	C-2R
B09.23.012C	Ba9s	9 x 23	12	1,2	C-2V
B09.23.012D	Ba9s	9 x 23	12	1,5	C-2V
B09.23.012F	Ba9s	9 x 23	12	2	C-2V
B09.23.012I	Ba9s	9 x 23	12	3	C-2V
B09.23.012P	Ba9s	8,8 x 26	12	4	C-2V
B09.23.024C	Ba9s	9 x 23	24	1,2	C-2F
B09.23.024F	Ba9s	9 x 23	24	2	C-2F
B09.23.024I	Ba9s	9 x 23	24	3	C-2F
B.09.23.024P	Ba9s	8,8 x 26	24	4	C-2F
B09.23.028F	Ba9s	9 x 23	28	2	C-2F
B09.23.030C	Ba9s	9 x 23	30	1,2	C-2F
B09.23.030F	Ba9s	9 x 23	30	2	C-2F
B09.23.030I	Ba9s	9 x 23	30	3	C-2F
B09.23.036E	Ba9s	9 x 23	36	1,8	C-2F

LAMPADINE LAMPS

BAIONETTA 9 X 23

Codice / Code	Base	Dimensioni	V	W	Filamento
B09.23.036I	Ba9s	9 x 23	36	3	C-2F
B09.23.048C	Ba9s	9 x 23	48	1,2	C-2F
B09.23.048F	Ba9s	9 x 23	48	2	C-2F
B09.23.048I	Ba9s	9 x 23	48	3	C-2F
B09.23.060C	Ba9s	9 x 23	60	1,2	C-2F
B09.23.060F	Ba9s	9 x 23	60	2	C-2F
B09.23.060G	Ba9s	9 x 23	60	2,4	C-2F
B09.23.060I	Ba9s	9 x 23	60	3	C-2F
B09.23.110F	Ba9s	9 x 23	110	2	C-5A
B09.23.130F	Ba9s	9 x 23	130	2	C-5A
B09.23.130H	Ba9s	9 x 23	130	2,6	C-5A
B09.23.160F	Ba9s	9 x 23	160	2	C-5A
B09.23.160I	Ba9s	9 x 23	160	3	C-5A
B09.23.220I	Ba9s	9 x 23	220	3	CC-7A
B09.23.240G	Ba9s	9 x 23	240	2,4	CC-7A
B09.23.250G	Ba9s	9 x 23	220/260	2/3	CC-7A

BAIONETTA 16 X 54

Codice / Code	Base	Dimensioni	V	W	Filamento
B16.54.006L	Ba15d	16 x 54	6	5	C-2R
B16.54.012L	Ba15d	16 x 54	12	5	C-2R
B16.54.024I	Ba15d	16 x 54	24	3	C-2V
DC004	Ba15d	16 x 54	24	5	C-2V
B16.54.024X	Ba15d	16 x 54	24	10	C-2V
B16.54.024Y	Ba15d	16 x 54	24	15	C-2V
B16.54.024Z	Ba15d	16 x 54	24	25	C-2V
B16.54.030L	Ba15d	16 x 54	30	5	C-2F
B16.54.048L	Ba15d	16 x 54	48	5	C-3A
B16.54.060L	Ba15d	16 x 54	60	5	C-3A
DC003	Ba15d	16 x 54	80	5	C-3A
B16.54.110L	Ba15d	16 x 54	110	5	C-5A
B16.54.130L	Ba15d	16 x 54	130	5	C-5A
B16.54.140L	Ba15d	16 x 54	110/140	3/5	C-5A
B16.54.160L	Ba15d	16 x 54	160	5	C-5A
B16.54.220L	Ba15d	16 x 54	220	5	C-7A
B16.54.220X	Ba15d	16 x 54	220	10	C-7A

LAMPADINE LAMPS

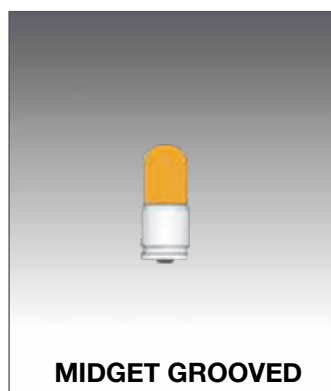

BAIONETTA 16 X 54

Codice / Code	Base	Dimensioni	V	W	Filamento
B16.54.220Y	Ba15d	16 x 54	220	15	C-7A
B16.54.230F	Ba15d	16 x 54	230	15	smerigliata
B16.54.240I	Ba15d	16 x 54	220/260	3/5	C-7A
B16.54.240L	Ba15d	16 x 54	220/260	5/7	C-7A
B16.54.260L	Ba15d	16 x 54	260	5	C-7A
B16.54.380L	Ba15d	16 x 54	380	5	CC-7A
B16.54.380X	Ba15d	16 x 54	380	10	CC-7A
B16.54.024C	Ba15d	16 x 54	24	3C	C-2V
B16.54.110C	Ba15d	16 x 54	110/130	3C	C-5A
B16.54.160C	Ba15d	16 x 54	160	3C	C-5A
B16.54.220C	Ba15d	16 x 54	220	3C	C-5A
B16.54.380C	Ba15d	16 x 54	380	3C	CC-7A

MIDGET GROOVED

Codice / Code	Base	Dimensioni	V	mA	MSCP	Filamento
G06.16.006V	T1 3/4	5,7 x 16	6	200	.60	C-2R
G06.16.014V	T1 3/4	5,7 x 16	14	80	.50	C-2V
G06.16.024P	T1 3/4	5,7 x 16	24	25	.15	C-2F
G06.16.024R	T1 3/4	5,7 x 16	24	40	.15	C-2F
G06.16.028P	T1 3/4	5,7 x 16	28	25	.15	C-2F
G06.16.028R	T1 3/4	5,7 x 16	28	40	.34	C-2F
G06.16.036O	T1 3/4	5,7 x 16	36	20	.20	CC-2F
G06.16.048O	T1 3/4	5,7 x 16	48	20	.15	CC-2F
G06.16.060O	T1 3/4	5,7 x 16	60	20	.30	CC-2F
G06.16.070P	T1 3/4	5,7 x 16	70	20	.30	CC-2F
GNO16.110	T1 3/4	5,7 x 16	110	neon	—	elettrodi
GNO16.220	T1 3/4	5,7 x 16	220	neon	—	elettrodi

LAMPADINE LAMPS

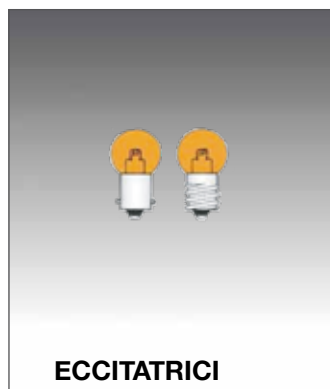

MIDGET FLANGED

Codice / Code	Base	Dimensioni	V	mA	MSCP	Filamento
F06.16.006V	T1 3/4	5,7 x 16	6	200	.60	C-2R
F06.16.012R	T1 3/4	5,7 x 16	12	40	.12	C-2V
F06.16.014R	T1 3/4	5,7 x 16	14	40	.15	C-2V
F06.16.014T	T1 3/4	5,7 x 16	14	80	.50	C-2V
F06.16.024P	T1 3/4	5,7 x 16	24	25	.15	C-2F
F06.16.024R	T1 3/4	5,7 x 16	24	40	.15	C-2F
F06.16.028P	T1 3/4	5,7 x 16	28	25	.15	C-2F
F06.16.028R	T1 3/4	5,7 x 16	28	40	.36	C-2F
F06.16.036O	T1 3/4	5,7 x 16	36	20	.20	CC-2F
F06.16.036R	T1 3/4	5,7 x 16	36	40	.30	CC-2F
F06.16.048O	T1 3/4	5,7 x 16	48	20	.15	CC-2F
F06.16.048P	T1 3/4	5,7 x 16	48	25	.20	CC-2F
F06.16.060O	T1 3/4	5,7 x 16	60	20	.30	CC-2F
F06.16.070P	T1 3/4	5,7 x 16	70	20	.30	CC-2F
FNO.16.110	T1 3/4	5,7 x 16	110	neon	—	elettrodi
FNO.16.220	T1 3/4	5,7 x 16	220	neon	—	elettrodi

ECCITATRICI

Codice / Code	Base	Dimensioni	V	W	GAS	Filamento
E90.71.004	E10	15 x 28	4	2	argon	C-6U
E90.59.006	E10	15 x 28	6	2	argon	C-6U
Codice / Code	Base	Dimensioni	V	W	GAS	Filamento
E90.69.004	Ba9s	15 x 28	4	2	argon	C-6U
E90.69.006	Ba9s	15 x 28	6	2	argon	C-6U

LAMPADINE SFERETTE 11 X 24 - 15 X 29

LAMPS SFERETTE

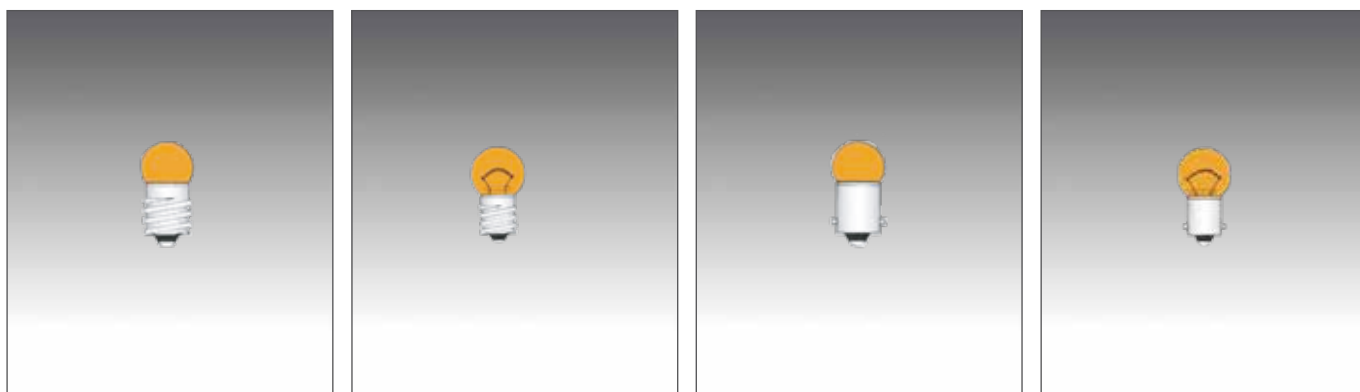

Codice / Code	Base	Dimensioni	V	W	Filamento
E11.24.001	E10	11 x 24	1,5	0,2A	C-2R
E11.24.002	E10	11 x 24	2,5	0,3A	C-2R
E11.24.103	E10	11 x 24	3,5	0,2A	C-2R
E11.24.003	E10	11 x 24	3,7	0,3A	C-2R
E11.24.203	E10	11 x 24	3,8	0,3A	C-2R
E11.24.004	E10	11 x 24	4,8	0,3A	C-2R
E11.24.206	E10	11 x 24	6	2	C-2R
E11.24.006	E10	11 x 24	6	3	C-2R
E11.24.012	E10	11 x 24	12	3	C-2V
E11.24.016	E10	11 x 24	16	3	C-2V
E11.24.024	E10	11 x 24	24	3	C-2F
E11.24.028F	E10	11 x 24	28	2	C-2F
E11.024.028	E10	11 x 24	28	3	C-2F
E11.24.048	E10	11 x 24	48	3	C-2F
E11.24.060	E10	11 x 24	60	3	C-2F

Codice / Code	Base	Dimensioni	V	W	Filamento
E15.28.006	E10	15 x 29	6	6 krypton	C-2R
E15.28.312	E10	15 x 29	12	3	C-2V
E15.28.012	E10	15 x 29	12	6 krypton	C-2V
E15.28.024	E10	15 x 29	24	5	C-2F

Codice / Code	Base	Dimensioni	V	W	Filamento
B11.24.006	Ba9s	11 x 24	6	3	C-2R
B11.24.012	Ba9s	11 x 24	12	3	C-2V
B11.24.024	Ba9s	11 x 24	24	3	C-2F

Codice / Code	Base	Dimensioni	V	W	Filamento
B15.28.006	Ba9s	15 x 29	6	6 krypton	C-2R
B15.28.312	Ba9s	15 x 29	12	3 - 2CP	C-2V
B15.28.012	Ba9s	15 x 29	12	6 krypton	C-2V
B15.28.024	Ba9s	15 x 29	24	5	C-2F

LAMPADINE LAMPS

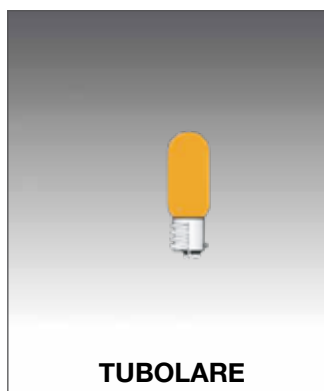
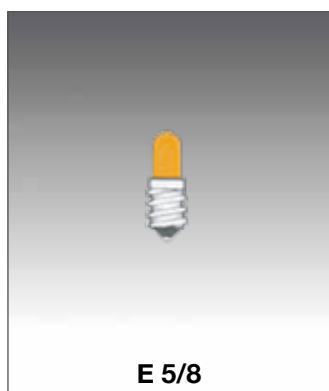
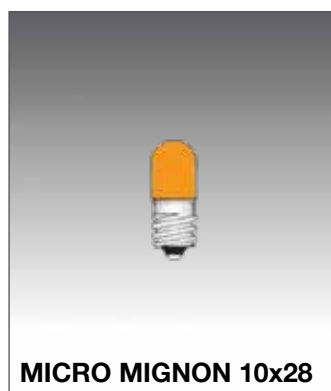

MICRO MIGNON 10 x 28

Codice / Code	Base	Dimensioni	V	W	Filamento
E10.28.006C	E10	10 x 28	6	1,2	C-2R
E10.28.006F	E10	10 x 28	6	2	C-2R
E10.28.006I	E10	10 x 28	6	3	C-2R
E10.28.006V	E10	10 x 28	6,3	250mA	C-2R
E10.28.012C	E10	10 x 28	12	1,2	C-2V
E10.28.012F	E10	10 x 28	12	2	C-2V
E10.28.012I	E10	10 x 28	12	3	C-2V
E10.28.024C	E10	10 x 28	24	1,2	C-2F
E10.28.024F	E10	10 x 28	24	2	C-2F
E10.28.024I	E10	10 x 28	24	3	C-2F
E10.28.028F	E10	10 x 28	28	2	C-2F
E10.28.030C	E10	10 x 28	30	1,2	C-2F
E10.28.030F	E10	10 x 28	30	2	C-2F
E10.28.030I	E10	10 x 28	30	3	C-2F
E10.28.036E	E10	10 x 28	36	1,8	C-2F
E10.28.036I	E10	10 x 28	36	3	C-2F
E10.28.048F	E10	10 x 28	48	2	C-2F
E10.28.048I	E10	10 x 28	48	3	C-2F
E10.28.060C	E10	10 x 28	60	1,2	C-2F
E10.28.060F	E10	10 x 28	60	2	C-2F
E10.28.060I	E10	10 x 28	60	3	C-2F
E10.28.080F	E10	10 x 28	80	2	C-3A
E10.28.120O	E10	10 x 28	110/130	20 mA	C-5A
E10.28.110F	E10	10 x 28	110	2	C-5A
E10.28.130F	E10	10 x 28	130	2	C-5A
E10.28.130H	E10	10 x 28	130	2,6	C-5A
E10.28.160I	E10	10 x 28	160	3	C-5A

LAMPADINE LAMPS

MICRO MIGNON 10 x 28

Codice / Code	Base	Dimensioni	V	W	Filamento
E10.28.220I	E10	10 x 28	220	3	C-5A
E10.28.240G	E10	10 x 28	240	2,4	C-5A
E10.28.250G	E10	10 x 28	220/260	2/3	CC-7A
E10.28.260I	E10	10 x 28	260	3	CC-7A

E 5/8

Codice / Code	Base	Dimensioni	V	W-mA	USA	MSCP
E05.17.003	T1 3/4	5,1 x 17,5	3,5	200		0,22
E05.17.006	T1 3/4	5,1 x 17,5	6	40		0,04
E05.17.406	T1 3/4	5,1 x 17,5	6	0.9W		0,32
E05.17.206	T1 3/4	5,1 x 17,5	6	200		0,50
E05.17.412	T1 3/4	5,1 x 17,5	12	40		0,15
E05.17.128	T1 3/4	5,1 x 17,5	12	80		0,30
E05.17.018	T1 3/4	5,1 x 17,5	18	40	373	0,30
E05.17.424	T1 3/4	5,1 x 17,5	24	40		0,24
E05.17.524	T1 3/4	5,1 x 17,5	24	1,2 W		0,20
E05.17.028	T1 3/4	5,1 x 17,5	28	40	335	0,34
E05.17.036	T1 3/4	5,1 x 17,5	36	20		0,80
E05.17.060	T1 3/4	5,1 x 17,5	60	20		0,15

TUBOLARE

Codice / Code	Base	Dimensioni	V	W	Filamento
B22.60.130 Y	Ba15d	22 x 60	130	15	C-5A
B22.60.130Z	Ba15d	22 x 60	130	25	C-5A
B22.60.240Y	Ba15d	22 x 60	240	15	CC-7A
B22.60.240Z	Ba15d	22 x 60	240	25	CC-7A
B26.80.240P	Ba15d	26 x 80	240	40	CC-7A

Codice / Code	Base	Dimensioni	V	W	Filamento
E22.60.130Y	E14	22 x 60	130	15	C-5A
E22.60.130Z	E14	22 x 60	130	25	C-5A
E22.60.240Y	E14	22 x 60	240	15	CC-7A
E22.60.240Z	E14	22 x 60	240	25	CC-7A
E20.80.024Z	E14	22 x 80	24	25	C-2F
E26.80.024Z	E14	26 x 80	24	25	C-2F
E26.80.024P	E14	26 x 80	24	40	C-2F
E26.80.130P	E14	26 x 80	130	40	C-5A
E26.80.240P	E14	26 x 80	240	40	CC-7A

LAMPADINE LAMPS

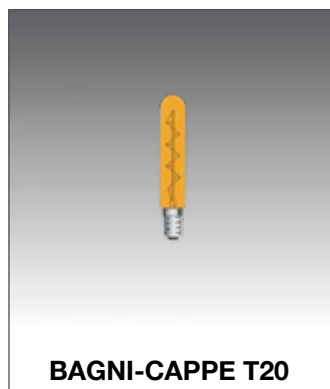

MICRO MIGNON 9 X 23

Codice / Code	Base	Dimensioni	V	W	Filamento
E09.23.006C	E10	9 x 23	6	1,2	C-2R
E09.23.006F	E10	9 x 23	6	2	C-2R
E09.23.006I	E10	9 x 23	6	3	C-2R
E09.23.012F	E10	9 x 23	12	2	C-2V
E09.23.012I	E10	9 x 23	12	3	C-2V
E09.23.024F	E10	9 x 23	24	2	C-2F
E09.23.024I	E10	9 x 23	24	3	C-2F
E09.23.030C	E10	9 x 23	28	2	C-2F
E.09.23.036E	E10	9 x 23	36	1,8	C-2F
E09.23.036I	E10	9 x 23	36	3	C-2F
E09.23.048F	E10	9 x 23	48	2	C-2F
E09.23.060C	E10	9 x 23	60	1,2	C-2F
E09.23.06F	E10	9 x 23	60	2	C-2F
E09.23.060I	E10	9 x 23	60	3	C-2F
E09.23.110F	E10	9 x 23	110	2	C-5A
E09.23.130H	E10	9 x 23	130	2,6	C-5A
E09.23.160F	E10	9 x 23	160	2	C-5A
E09.23.220I	E10	9 x 23	220	3	CC-7A
E09.23.240G	E10	9 x 23	240	2,4	CC-7A

BAGNI-CAPPE T20

Codice / Code	Base	Dimensioni	V	W	Filamento
E20.15.220	E14	20 x 112	220	15	C-8Z
E20.25.220	E14	20 x 112	220	25	C-8Z
E20.40.220	E14	20 x 112	220	40	C-8Z

LAMPADINE LAMPS

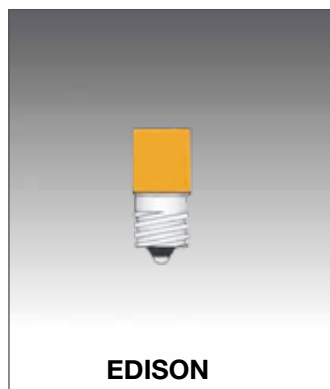

EDISON

Codice / Code	Base	Dimensioni	V	W	Filamento
E14.30.006C	E14	14 x 30	6	1,2	C-2R
E14.30.012I	E14	14 x 30	12	3	C-2R
E14.30.024I	E14	14 x 30	24	3	C-2V
E14.30.030I	E14	14 x 30	30	3	C-2F
E14.30.048I	E14	14 x 30	48	3	C-3A
E14.30.060I	E14	14 x 30	60	3	C-3A
E14.30.130H	E14	14 x 30	130	2,6	C-5A
E14.30.220I	E14	14 x 30	220	3	CC-7A

Codice / Code	Base	Dimensioni	V	W	Filamento
E16.35.006L	E14	16 x 35	6	5	C-2R
E16.35.012L	E14	16 x 35	12	5	C-2R
E16.35.024I	E14	16 x 35	24	3	C-2V
E16.35.024L	E14	16 x 35	24	5	C-2V
E16.35.030I	E14	16 x 35	30	3	C-2F
E16.35.030L	E14	16 x 35	30	5	C-2F
E16.35.036L	E14	16 x 35	36	5	C-2F
E16.35.048I	E14	16 x 35	48	3	C-3A
E16.35.048L	E14	16 x 35	48	5	C-3A
E16.35.060I	E14	16 x 35	60	3	C-3A
E16.35.060L	E14	16 x 35	60	5	C-3A
E16.35.130L	E14	16 x 35	130	5	C-5A
E16.35.160L	E14	16 x 35	160	5	C-5A
E16.35.220L	E14	16 x 35	220	5	CC-7A
E16.35.240L	E14	16 x 35	240	5	CC-7A
E16.35.260L	E14	16 x 35	220/260	3/5	CC-7A
E16.35.260H	E14	16 x 35	220/260	5/7	CC.7A

LAMPADINE SILURO LAMPS SILURO

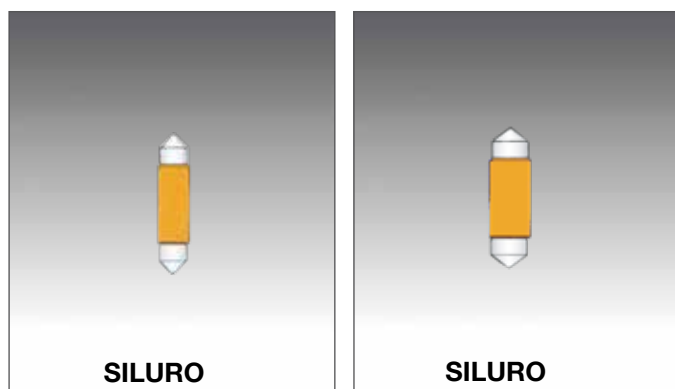

SILURO

Codice / Code	Base	Dimensioni	V	W	Durata
S06.28.006	S6	6 x 28 ± 1	6	3	1.000
S06.28.012	S6	6 x 28 ± 1	12	3	1.000
S06.28.024D	S6	6 x 28 ± 0,5	24	1,5	2.000
S06.28.024	S6	6 x 28 ± 1	24	3	1.000
S06.28.030	S6	6 x 28 ± 1	30	3	1.000

Codice / Code	Base	Dimensioni	V	W	Durata
S06.31.006	S6	6 x 31 ± 1	6	3	1.000
S06.31.012D	S6	6 x 31 ± 0,5	12	1,5	2.000
S06.31.012	S6	6 x 31 ± 1	12	3	1.000
S06.31.015D	S6	6 x 31 ± 0,5	15	1,5	2.000
S06.31.015F	S6	6 x 31 ± 0,5	15	2	2.000
S06.31.025D	S6	6 x 31 ± 0,5	24	1,5	2.000
S06.31.024	S6	6 x 31 ± 1	24	3	1.000
S06.31.030	S6	6 x 31 ± 0,5	30	1,5	2.000
S06.31.030I	S6	6 x 31 ± 0,5	30	3	2.000
S06.31.036	S6	6 x 31 ± 0,5	36	3	2.000

Codice / Code	Base	Dimensioni	V	W	Durata
S06.36.006	S6	6 x 36 ± 1	6	3	1.000
S06.36.012	S6	6 x 36 ± 1	12	3	1.000
S06.36.024	S6	6 x 36 ± 1	24	3	1.000
S06.36.036	S6	6 x 36 ± 0,5	36	3	2.000
S06.36.048	S6	6 x 36 ± 0,5	48	3	2.000
S06.36.060	S6	6 x 36 ± 0,5	60	3	2.000

LAMPADINE SILURO LAMPS SILURO

SILURO

Codice / Code	Base	Dimensioni	V	W	Durata
S06.38.006	S6	6 x 38 ± 1	6	3	1.000
S06.38.012	S6	6 x 38 ± 1	12	3	1.000
S06.38.015	S6	6 x 38 ± 0,5	15	3	2.000
S06.38.024	S6	6 x 38 ± 1	24	3	1.000
S06.38.030	S6	6 x 38 ± 0,5	30	3	2.000
S06.38.036	S6	6 x 38 ± 0,5	36	3	2.000
S06.38.048	S6	6 x 38 ± 0,5	48	3	2.000

Codice / Code	Base	Dimensioni	V	W	Durata
S08.31.006	S7	8 x 31 ± 1	6	3	1.000
S08.31.012D	S7	8 x 31 ± 0,5	12	1,5	2.000
S08.31.012	S7	8 x 31 ± 1	12	3	1.000
S08.31.012L	S7	8 x 31 ± 1	12	5	1.000
S08.31.015	S7	8 x 31 ± 0,5	15	3	2.000
S08.31.024C	S7	8 x 31 ± 0,5	24	1,2	2.000
S08.31.024D	S7	8 x 31 ± 0,5	24	1,5	2.000
S08.31.024	S7	8 x 31 ± 1	24	3	1.000
S8.31.030	S7	8 x 31 ± 0,5	30	3	2.000
S08.31.030L	S7	8 x 31 ± 0,5	30	5	2.000
S08.31.032	S7	8 x 31 ± 0,5	32	3	2.000
S08.31.048	S7	8 x 31 ± 0,5	48	5	2.000
S08.31.060	S7	8 x 31 ± 0,5	60	3	2.000

Codice / Code	Base	Dimensioni	V	W	Durata
S08.36.006	S7	8 x 36 ± 1	6	3	1.000
S08.36.012	S7	8 x 36 ± 1	12	3	1.000
S08.36.024	S7	8 x 36 ± 1	24	3	1.000
S08.36.030	S7	8 x 36 ± 0,5	30	3	2.000
S08.36.060	S7	8 x 36 ± 0,5	60	3	2.000

Codice / Code	Base	Dimensioni	V	W	Durata
S08.39.012D	S7	8 x 39 ± 0,5	12	1,5	2.000
S08.38.012X	S7	8 x 39 ± 0,5	12	10	2.000
S08.39.024D	S7	8 x 39 ± 0,5	24	1,6	2.000
S08.39.30	S7	8 x 39 ± 0,5	30	3	2.000

LAMPADINE LAMPS

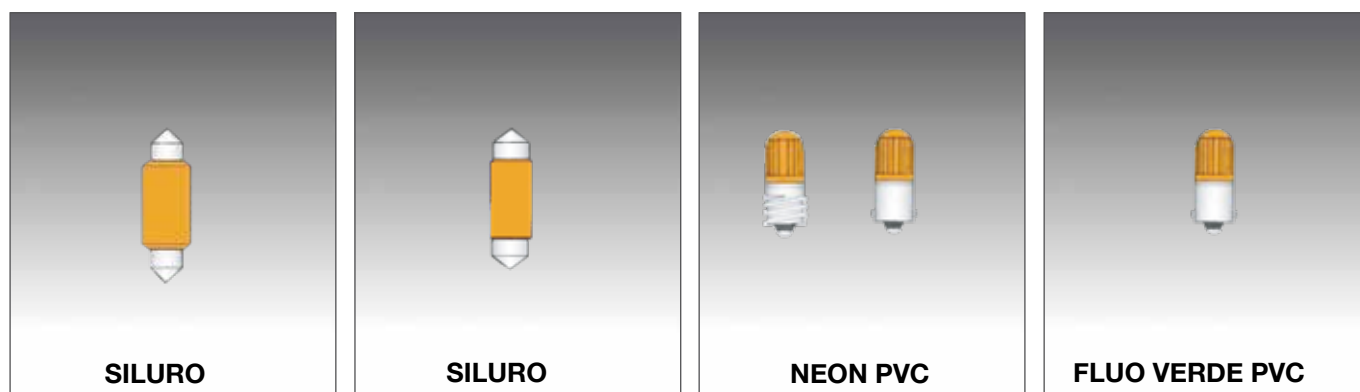

SILURO

Codice / Code	Base	Dimensioni	V	W
S11.39.006	S8,5	11 x 39 ± 1	6	5
S11.39.106	S8,5	11 x 39 ± 1	6	10
S11.39.312	S8,5	11 x 39 ± 1	12	3
S11.39.012	S8,5	11 x 39 ± 1	12	5
S11.39.024	S8,5	11 x 39 ± 1	24	5
S11.39.124	S8,5	11 x 39 ± 1	24	10
S11.39.030	S8,5	11 x 39 ± 0,5	30	3
S11.39.048	S8,5	11 x 39 ± 0,5	48	5
S11.30.060	S8,5	11 x 39 ± 0,5	60	5

Codice / Code	Base	Dimensioni	V	W
S11.44.106	S8,5	11 x 44 ± 1	6	5
S11.44.012D	S8,5	11 x 44 ± 1	12	1,5
S11.44.012	S8,5	11 x 44 ± 1	12	3
S11.44.112	S8,5	11 x 44 ± 1	12	5
S11.44.212	S8,5	11 x 44 ± 1	12	10
S11.44.124	S8,5	11 x 44 ± 1	24	5
S11.44.224	S8,5	11 x 44 ± 1	24	10
S11.44.030	S8,5	11 x 44 ± 0,5	30	5
S11.44.048	S8,5	11 x 44 ± 0,5	48	5

LAMPADINE LAMPS

SILURO

Codice / Code	Base	Dimensioni	V	W
S15.44.306	S8,5	15 x 44 ± 1	6	15
S15.44.112	S8,5	15 x 44 ± 1	12	5
S15.44.212	S8,5	15 x 44 ± 1	12	10
S15.44.312	S8,5	15 x 44 ± 1	12	18
S15.44.412	S8,5	15 x 44 ± 1	12	20
S15.44.124	S8,5	15 x 44 ± 1	24	5
S15.44.224	S8,5	15 x 44 ± 1	24	10
S15.44.324	S8,5	15 x 44 ± 1	24	15
S15.44.024	S8,5	15 x 44 ± 1	24	18
S15.44.030	S8,5	15 x 44 ± 0,5	30	10

23

NEON PVC

Codice / Code	Base	Dimensioni	V	W	Filamento
BNP.28.110	Ba9s	10 x 23	110	1,8	rosso
BNP.28.220	Ba9s	10 x 23	220	1,8	rosso
BNP.28.380	Ba9s	10 x 23	380	1,8	rosso

Codice / Code	Base	Dimensioni	V	W	Filamento
ENP.28.110	E10	10 x 28	110	1,8	rosso
ENP.28.220	E10	10 x 28	220	1,8	rosso
ENP.28.380	E10	10 x 28	380	1,8	rosso

FLUO VERDE PVC

Codice / Code	Base	Dimensioni	V	W	Filamento
BFP.28.110	Ba9s	10 x 28	110	1,8	verde
BFP.28.220	Ba9s	10 x 28	220	1,8	verde
BFP.28.380	Ba9s	10 x 28	380	1,8	verde

LAMPADINE LAMPS

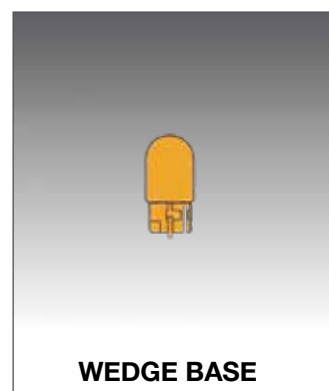
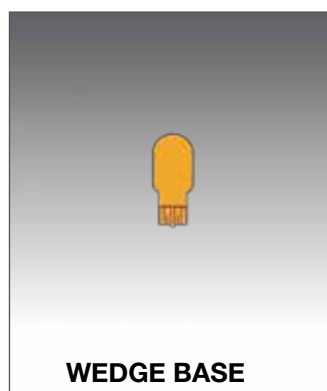
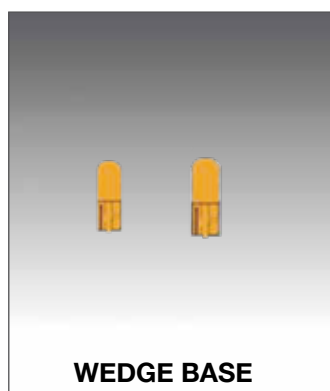

NEON

Codice / Code	Base	Dimensioni	V	W
SN6.28.110	S6	6 x 28 ± 1	110	neon
SN6.28.220	S6	6 x 28 ± 1	220	neon
SN6.28.380	S6	6 x 28 ± 1	380	neon
SF6.28.110	S6	6 x 28 ± 1	110	fluo-verde
SF6.28.220	S6	6 x 28 ± 1	220	fluo-verde
SF6.28.380	S6	6 x 28 ± 1	380	fluo-verde

WEDGE BASE

Codice / Code	Base	Dimensioni	V	W-mA
DC013	T5	5 x 20	6	1
			6	1,2
			12	1,2
			24	1
			24	1,2
			28	40mA
			30	40mA

Codice / Code	Base	Dimensioni	V	W-mA
W10.28.006	T10	10 x 28	6	3
W10.28.163	T10	10 x 28	6,3	150mA
W10.28.063	T10	10 x 28	6,3	250mA
W10.28.112	T10	10 x 28	12	1,2
W10.28.115	T10	10 x 28	12	1,5
W10.28.212	T10	10 x 28	12	2
W10.28.312	T10	10 x 28	12	3-2CP
W10.28.512	T10	10 x 28	12	5
W10.28.512A	T10	10 x 28	12	5

LAMPADINE LAMPS

WEDGE BASE

Codice / Code	Base	Dimensioni	V	W-mA
W10.28.512B	T10	10 x 28	12	5
W10.28.224	T10	10 x 28	24	2
W10.28.324	T10	10 x 28	24	3
W10.28.524	T10	10 x 28	24	5
W10.28.028	T10	10 x 28	28	60mA
W10.28.060	T10	10 x 28	48/60	40mA

Codice / Code	Base	Dimensioni	V	W-mA
W15.125	T15	15 x 36	12	5
W15.1216	T15	15 x 36	12	16
W15.1216A	T15	15 x 36	12	16
W15.1221	T15	15 x 36	12	21
W15.1221A	T15	15 x 36	12	21
W15.1281	T15	15 x 36	12,8	12,8
W15.2421	T15	15 x 36	24	21

Codice / Code	Base	Dimensioni	V	W-mA
W20.1221	T20	20 x 48	12	21
W20.1221A	T20	20 x 48	12	21
W20.12521	T20	20 x 48	12	5/21
W20.12521A	T20	20 x 48	12	5/21

LAMPADINE NEON VETRO LAMPS NEON GLASS

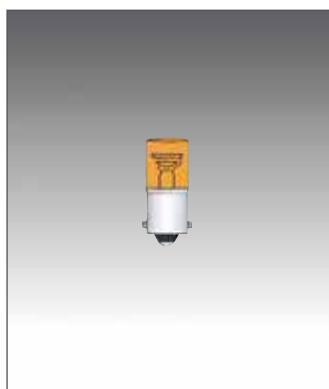
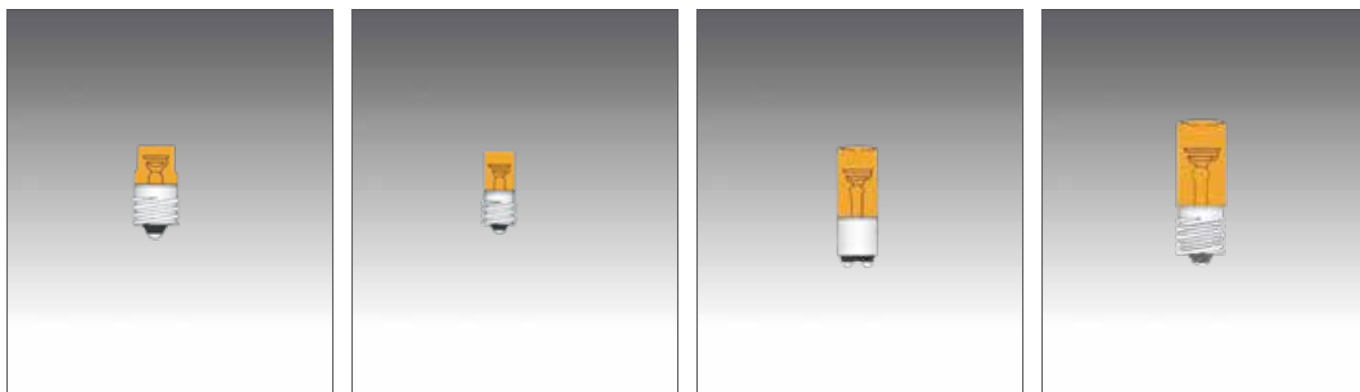

Codice / Code	Base	Dimensioni	V	mA	Filamento
BNO.28.110	Ba9s	9 x 25	110	0,9	rosso
BNO.28.220	Ba9s	9 x 25	220	1,3	rosso
BNO.28.380	Ba9s	9 x 25	380	0,9	rosso

Codice / Code	Base	Dimensioni	V	mA	Filamento
ENO.28.110	E10	10 x 28	110	0,9	rosso
ENO.28.220	E10	10 x 28	220	1,3	rosso
ENO.28.380	E10	10 x 28	380	0,9	rosso

Codice / Code	Base	Dimensioni	V	mA	Filamento
BNO.54.110	Ba15d	16 x 54	110	2	rosso
BNO.54.220	Ba15d	16 x 54	220	3	rosso
BNO.54.380	Ba15d	16 x 54	380	2	rosso

Codice / Code	Base	Dimensioni	V	mA	Filamento
ENO.30.110	E14	14 x 30	110	1,3	rosso
ENO.30.220	E14	14 x 30	220	2,6	rosso
ENO.30.380	E14	14 x 30	380	1,5	rosso
ENO.54.110	E14	16 x 54	110	2	rosso
ENO.54.220	E14	16 x 54	220	3	rosso
ENO.54.380	E14	16 x 54	380	2	rosso

LAMPADINE MONOLED 10 LAMPS MONOLED 10

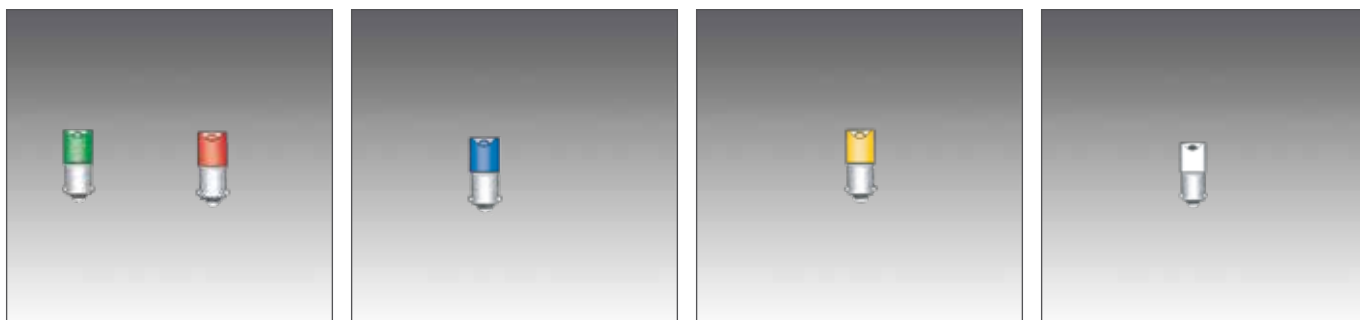

MONOLED E10

Codice / Code	Base	colore	nm	V ac	mA	mCD	angolo
1E10.006R	E10	rosso	666	6 (max8)	20	4800	20
1E10.006V	E10	verde	520	6 (max8)	20	4000	20
1E10.006G	E10	ambra	585	6 (max8)	20	3700	20
1E10.006W	E10	bianco	0,3X - 0,3Y	6 (max8)	20	6000	20
1E10.006B	E10	blu	468	6 (max8)	20	1800	15
1E10.012R	E10	rosso	666	12 (max16)	20	4800	20
1E10.012V	E10	verde	520	12 (max16)	20	4000	20
1E10.012G	E10	ambra	585	12 (max16)	20	3700	20
1E10.012W	E10	bianco	0,3X - 0,3Y	12 (max16)	20	6000	20
1E10.012B	E10	blu	468	12 (max16)	20	1800	15
1E10.024R	E10	rosso	666	24 (max30)	20	4800	20
1E10.024V	E10	verde	520	24 (max30)	20	4000	20
1E10.240G	E10	ambra	585	24 (max30)	20	3700	20
1E10.024W	E10	bianco	0,3X-0,3Y	24 (max30)	20	6000	20
1E10.024B	E10	blu	468	24 (max30)	20	1800	15
1E10.048R	E10	rosso	666	48 (MAX 60)	10	2500	20
1E10.048V	E10	verde	520	48 (MAX 60)	10	2500	20
1E10.048G	E10	ambra	585	48 (MAX 60)	10	1900	20
1E10.048W	E10	bianco	0,3X-0,3Y	48 (MAX 60)	10	3000	20
1E10.0.048B	E10	blu	468	48 (MAX 60)	10	900	15
1E10.11R	E10	rosso	666	110 (max130)	4	1400	20
1E10.110V	E10	verde	520	110 (max130)	4	1200	20
1E10.110G	E10	ambra	585	110 (max130)	4	1100	20
1E10.110W	E10	bianco	0.3X-0,3Y	110 (max130)	4	1600	20
1E10.110B	E10	blu	468	110 (max130)	4	600	15
1E10.220R	E10	rosso	666	220 (max240)	2	800	20
1E10.220V	E10	verde	520	220 (max240)	2	700	20
1E10.220G	E10	ambra	585	220 (max240)	2	600	20
1E10.220W	E10	bianco	0,3X-0,3Y	220 (max240)	2	1000	20
1E10.220B	E10	blu	468	220 (max240)	2	500	15

PLAFONIERE CEILING LIGHT

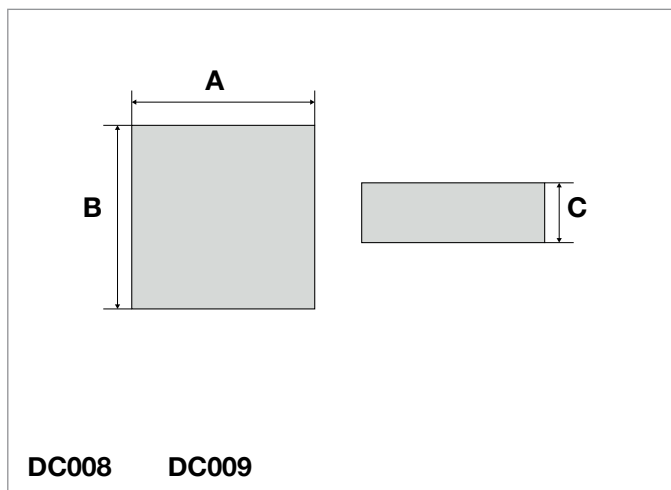
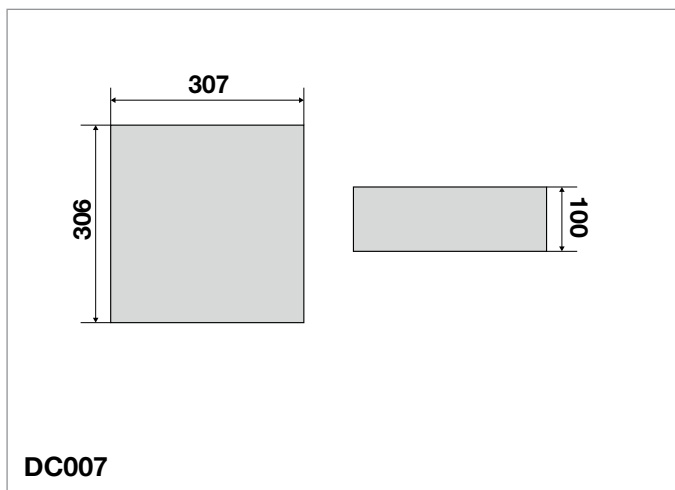
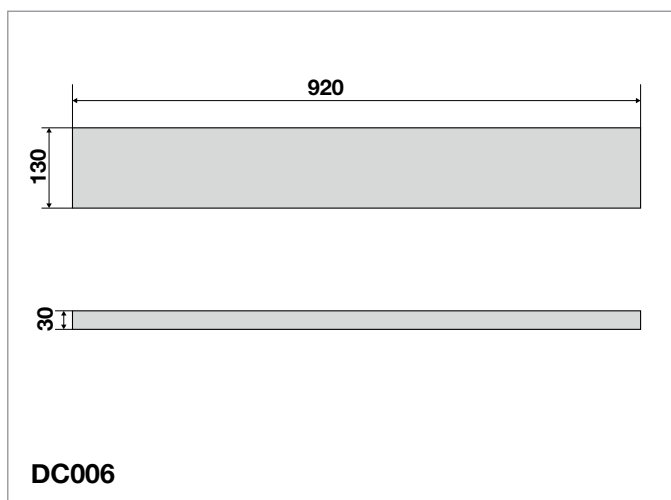
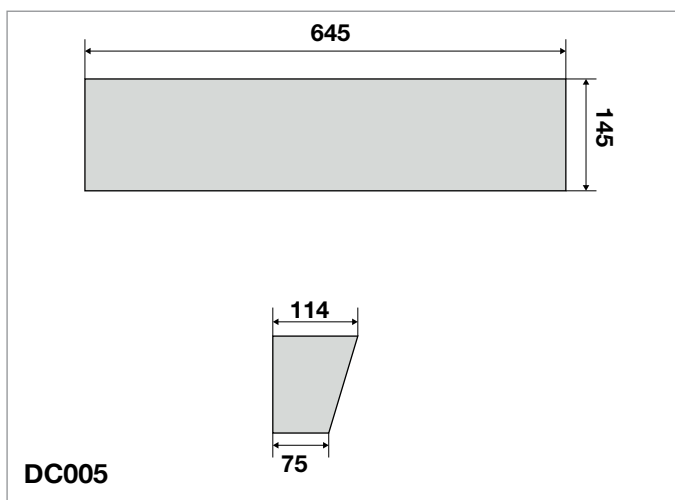
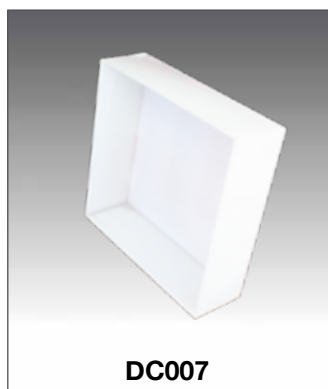
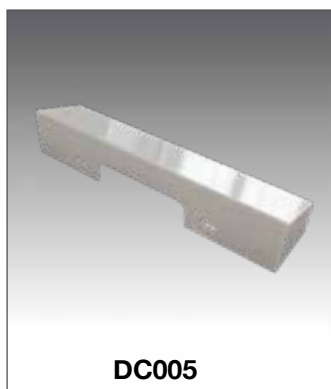

Codice / Code	Base
DC005	Plafoniera SCHINDLER
DC006	Plafoniera OTIS
DC007	Plafoniera BASSETTI

Codice / Code	Base	A	B	C
DC008	Plafoniera LED per cabina 22W	270	270	65
DC009	Plafoniera cabina 36W 4000K	400	400	65

LAMPADE PORTATILI PORTABLE LAMPS



Codice / Code	Descrizione
307	Lampada portatile gabbia in lamiera con cavo da 5 mt.

OPERATORE - MOTORIZZAZIONE

OPERATOR - DRIVE UNIT

Motorizzazione E5 AZ per automazione porta di piano montata su montante verticale per home lift 24.2

Drive unit E5 AZ for landing door mounted on door vertically for home lift

Motorizzazione DV SPRINT per automazione porta di piano montata sulla traversa del telaio 24.3

Drive unit DV SPRINT for landing door mounted on the frame

Note: I componenti sul catalogo con riportata una specifica marca di ascensore sono utilizzati abitualmente solo da questa marca. I particolari senza marca sono utilizzati da più marche di ascensori.

Note: *The components in the catalogue with a specific lift brand are usually used only by the brand. Unbranded parts are used by multiple lift brands.*

MOTORIZZAZIONE E5 AZ PER HOME LIFT DRIVE UNIT E5 AZ FOR HOME LIFT



Motorizzazione extracompatta montaggio su montante verticale del telaio.
Elegante, compatto e concepito per traffico limitato.
Disponibile anche con braccio a slitta.

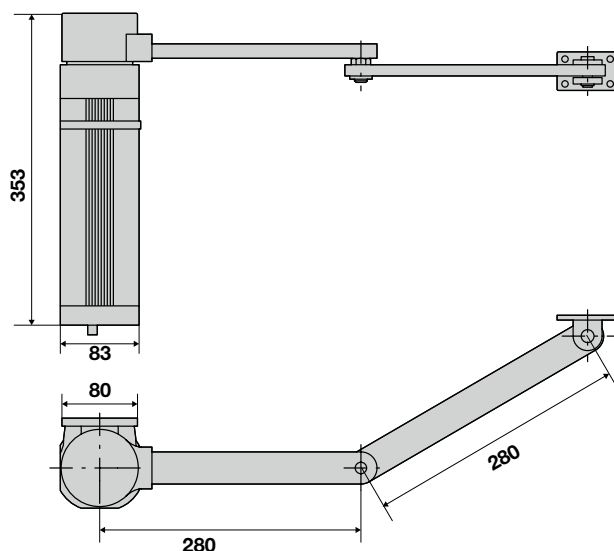

E5AZ

Dati tecnici

Centrale di comando	RIGEL 6	Tipo finecorsa	Tempo di lavoro
Alimentazione scheda	230 V	Rallentamento	No
Tensione motore	230 V	Blocco	Elettroserratura
Potenza assorbita	200 W	Sblocco	Reversibile
Larghezza max. battente	1.8 m	Reazione all'urto	Frizione meccanica
Peso max. battente	200 kg	Frequenza utilizzo	Semi intensivo
Angolo massimo	130 °	Grado di protezione	IP44
Tempo manovra	22 s	Condizioni ambientali	-10 ÷ 60 °C

Codice / Code	Descrizione
E5AZ	Motorizzazione porta battente Home Lift con braccio a compasso

MOTORIZZAZIONE DV SPRINT DRIVE UNIT SPRINT



DV SPRINT

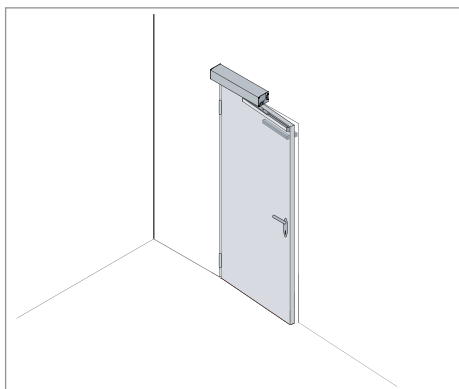

La motorizzazione DV SPRINT è adatta per porte d'ascensore.

Si monta sull'architrave superiore, ed è dotata di sistema antischiacciamento elettronico.

The driver unit DV SPRINT is suitable for lift doors mounted on the top of architrave, the system is equipped with electronic anti-crushing.

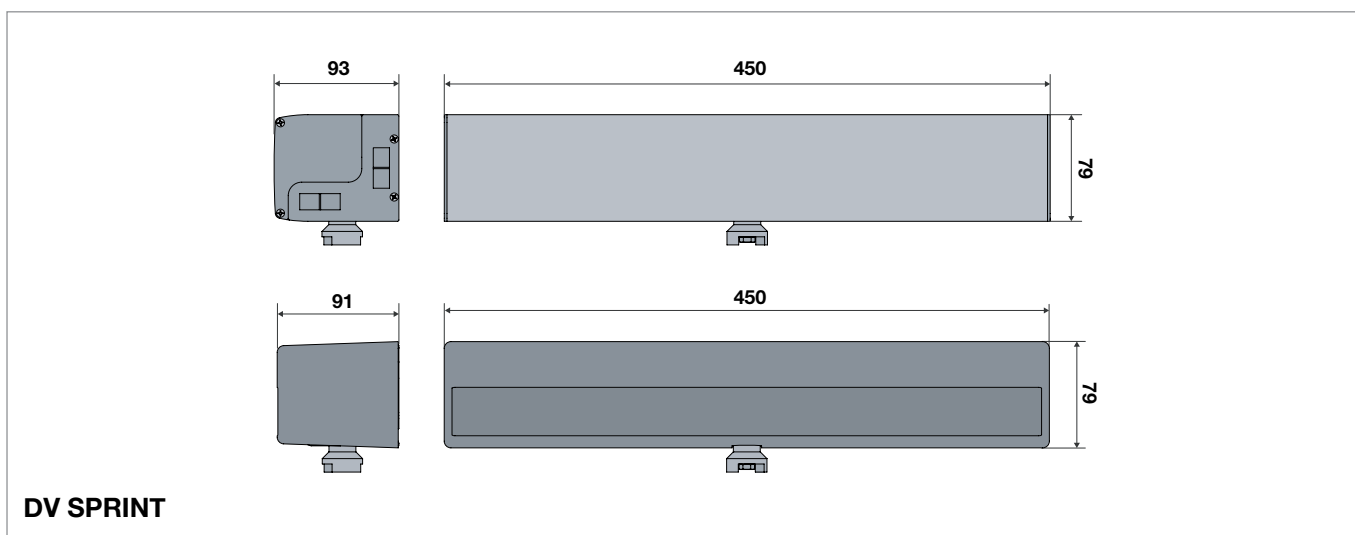

DV SPRINT

Dati tecnici

Gestione corsa	encoder	Tempo chiusura	4÷7 s/90° (regolabile)
Portata massima	110 kg	Tempo pausa porta aperta	0÷30 s
Angola massimo di apertura anta	100°	Temperatura di funzionamento	-20°C / +55°C (-10°C / +50°C batterie)
Test di durata	1 milione cicli	Grado protezione	IP 30
Alimentazione	24 Vcc 230 Vca / 50-60 Hz	Protezione elettrica	classe I classe II
Consumo	120 W	Dimensioni prodotto	79x93x450 mm
Potenza ausiliaria	300 mA - 24 Vcc	Peso prodotto	3,5 kg
Tempo di apertura	3÷6 s/90° (regolabile)	Quadro di comando	EL38

Codice / Code	Descrizione
DV SPRINT	Motorizzazione DV SPRINT

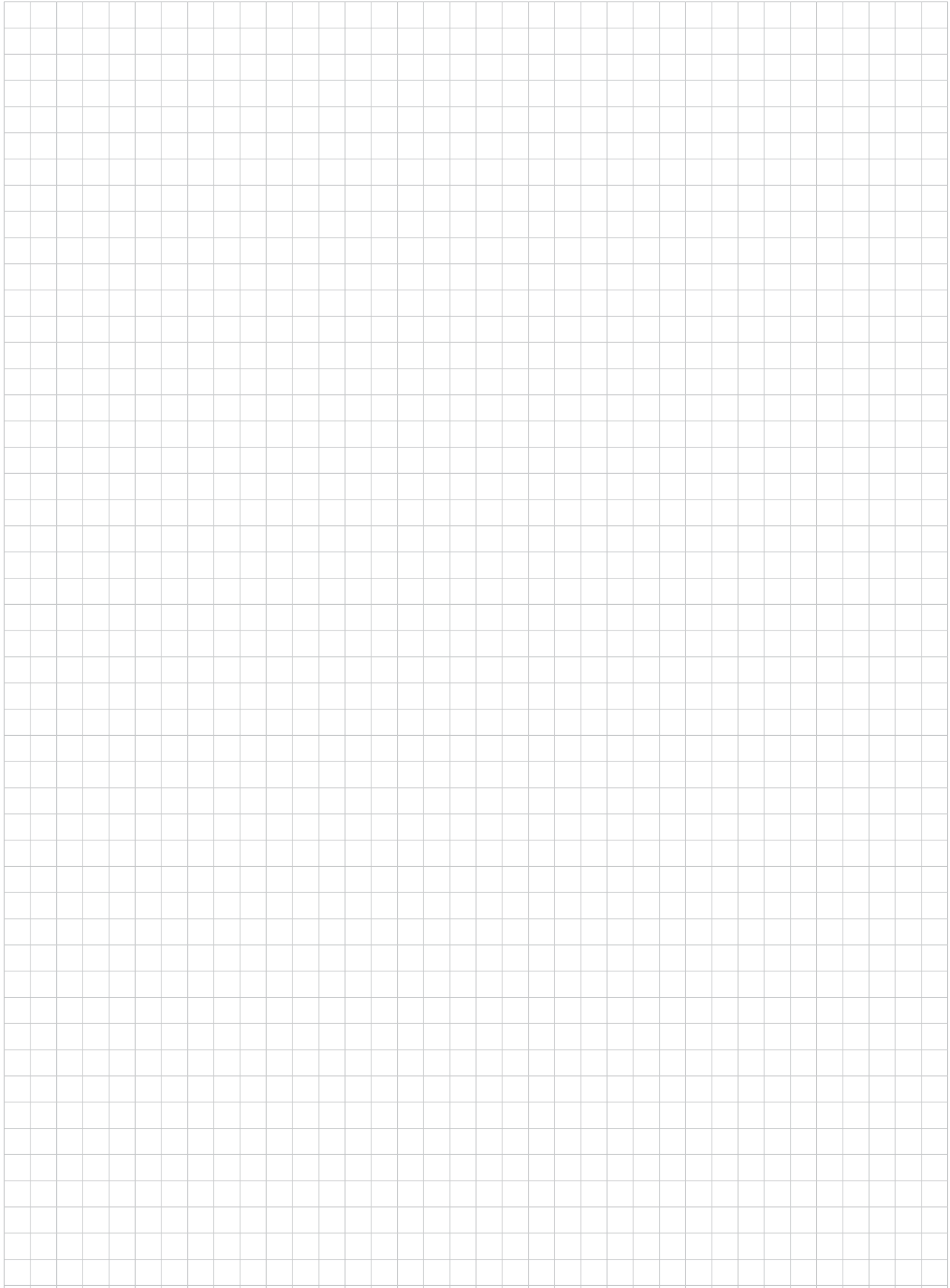

NOTE

SELETTORI
SELECTORS

Camma e molla Omega selettore SCHINDLER	25.5
<i>Cams and springs Omega for selector SCHINDLER</i>	
Martelletto selettore SCHINDLER	25.3
<i>Hammer switch SCHINDLER</i>	
Plot per disco selettore	25.5
<i>Plot for selector disc</i>	
Ricambi selettori a martelletto SCHINDLER	25.4
<i>Spare parts selectors and hammer switch SCHINDLER</i>	
Selettore elettrico SIL	25.2
<i>Electronic selector SIL</i>	
Selettore OTIS Buma - ricambi selettori OTIS - nastro metallico forato selettore OTIS	25.6-25-7
<i>Selector OTIS Buma - Spare parts for selector OTIS - metallic sprocket selector OTIS</i>	

Note: I componenti sul catalogo con riportata una specifica marca di ascensore sono utilizzati abitualmente solo da questa marca. I particolari senza marca sono utilizzati da più marche di ascensori.

Note: *The components in the catalogue with a specific lift brand are usually used only by the brand. Unbranded parts are used by multiple lift brands.*

SELETTORE TIPO SIL ELECTRONIC SELECTOR SIL

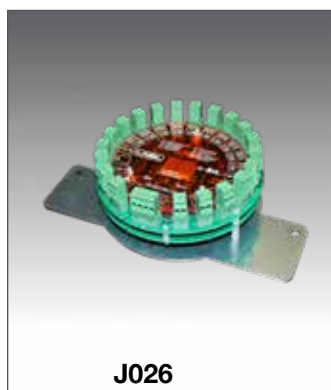

J026



J027

Il selettore elettronico SIL è una scheda elettronica concepita per il conteggio dei piani degli impianti ascensori, ed è stata principalmente ideata per sostituire il vecchio selettore SIL di nostra produzione, del quale riproduce fedelmente le dimensioni meccaniche e le caratteristiche elettriche.

Il selettore elettronico SIL è inoltre adatto a sostituire qualsiasi selettore elettromeccanico, o i vecchi commutatori.

La logica a microprocessore consente di adattarlo a qualsiasi tipo di installazione, con un ampio range di tensioni. Può gestire impianti fino a 12 fermate ed integra il controllo del tempo corsa e dei termistori, evitando così cablaggi e costi aggiuntivi per componenti esterni. Sono inoltre disponibili 12 uscite a relè.

Caratteristiche elettriche

Tensione di alimentazione	Da 35 a 85VDC
Consumo	15W @ 85VDC
Temperatura di funzionamento	+0°..... +70°C
Temperatura di immagazzinamento	-40°.....+120°
Tensione ingressi optoisolati	Da 35 a 140VDC
Caratteristiche elettriche contatti relè di posizione e di allarme	5A @ 30VDC / 230VAC
Caratteristiche elettriche contatti relè direzionali	12A @ 24VDC / 230VAC - protetti con varistori
Tensione di alimentazione / soglia di intervento ingresso PTC	2,5V / ~ 2,0K Ohm
Microprocessore	PIC32MX - 40MHZ
Memoria parametri / posizione	FRAM 4kbit
Tensione di alimentazione / sogli di intervento ingresso PTC	2,5V / ~ 2,0k Ohm

Codice / Code	Descrizione
J026	Selettore elettronico fino a 12 fermate per impianti fino a 85V.
J027	Alimentatore con ingresso 88-264 V. AC. per selettore SIL - impianti superiori a 85V.

MARTELLETTO SCHINDLER HAMMER SWITCH SCHINDLER



Martelletto selettore
rotella Ø 25



Martelletto selettore
rotella Ø 14



050116/1

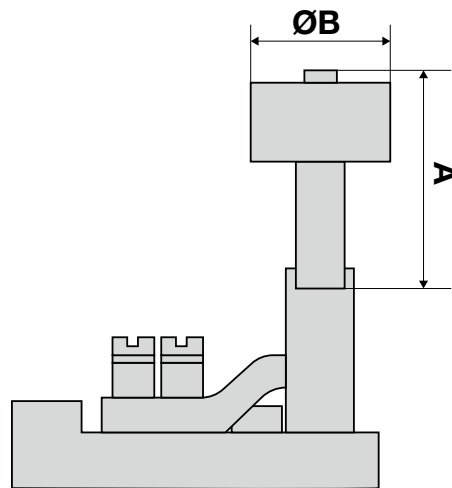

Martelletto selettore SCHINDLER

25

Codice / Code	Descrizione	ØB	A
050113	Martelletto selettore SCHINDLER rotella Ø 25	25	41
050114	Martelletto selettore SCHINDLER rotella Ø 25	25	60
050115	Martelletto selettore SCHINDLER rotella Ø 25	25	81
050116	Martelletto selettore SCHINDLER rotella Ø 25	25	30
050117	Martelletto selettore SCHINDLER rotella Ø 14	14	30
050118	Martelletto selettore SCHINDLER rotella Ø 14	14	40
050119	Martelletto selettore SCHINDLER rotella Ø 14	14	35
050116/1	Martelletto selettore SCHINDLER leva corta rotella Ø 25	25	30

RICAMBI MARTELLETTO SCHINDLER
SPARE PARTS SELECTORS AND HAMMER SWITCH SCHINDLER

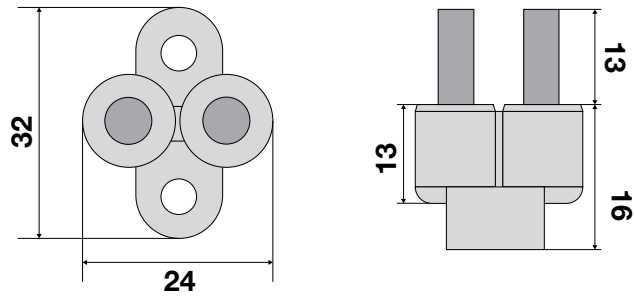
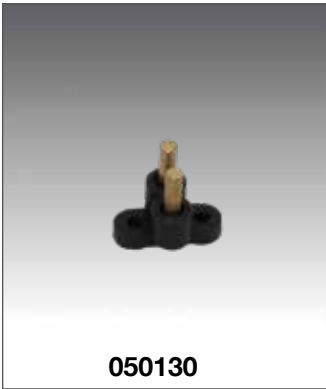

050130

25

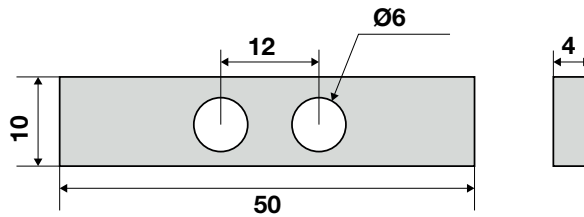

050131

Codice / Code	Note
050130	Supporto ponte di contatto selettore SCHINDLER
050131	Ponte per contatto selettore SCHINDLER

RICAMBI SELETTORE SCHINDLER SPARE PARTS SELECTORS SCHINDLER

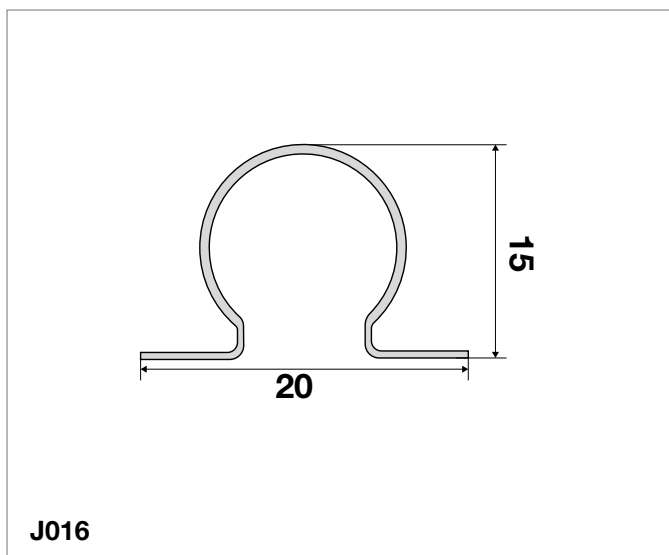
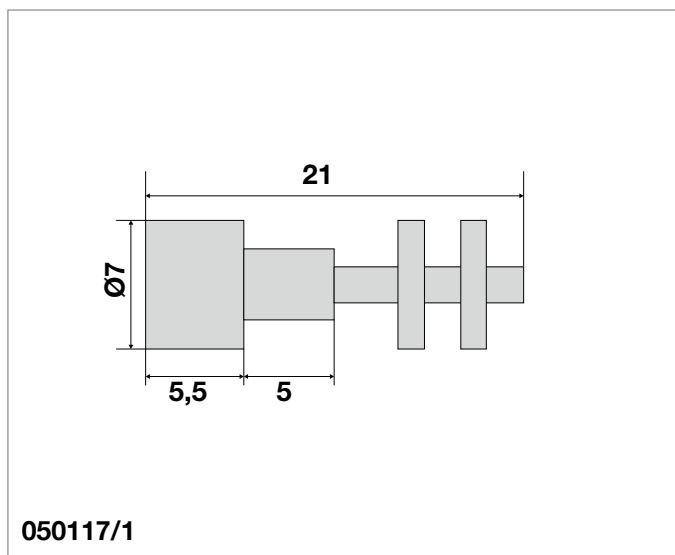
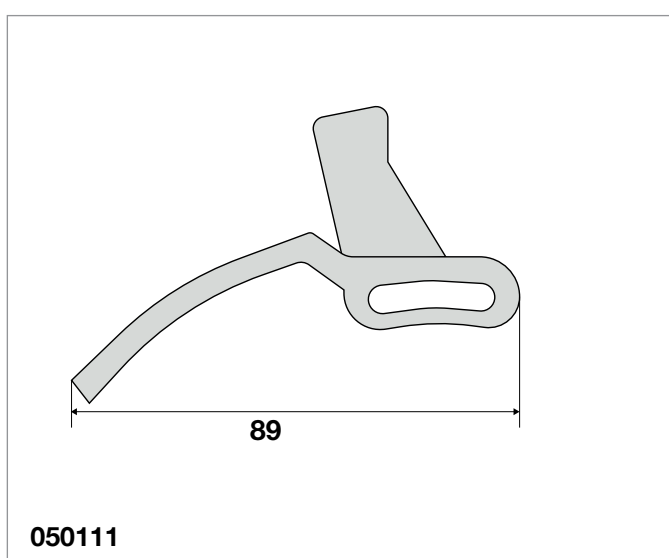
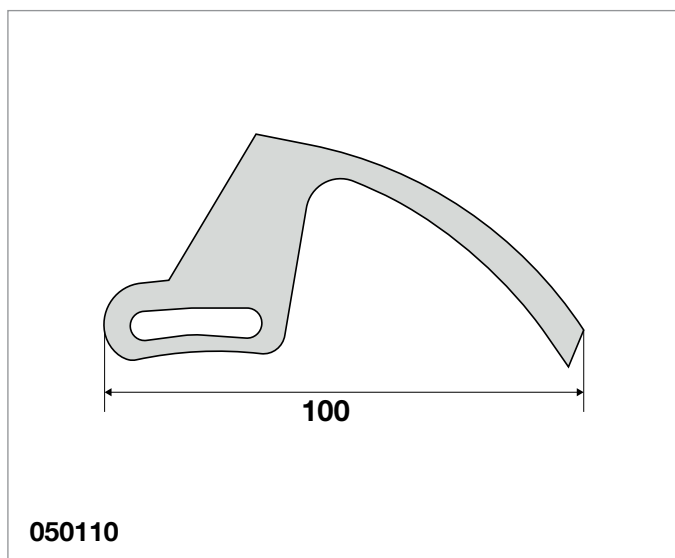

25

Codice / Code	Descrizione
050110	Camma selettore SCHINDLER SX
050111	Camma selettore SCHINDLER DX
050117/1	Plot per disco selettore SCHINDLER
J016	Molla OMEGA martelletto selettore SCHINDLER

SELETTORE OTIS E RICAMBI SPARE PARTS SELECTOR OTIS

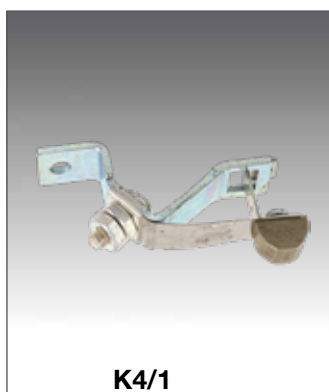
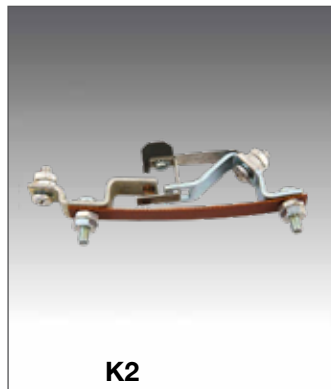

25

Codice / Code	Descrizione
K1	Contatto selettore 6839Y-2-4 per selettore OTIS 6104-7039 (plastica)
K2	Contatto selettore 6839Y-3 per selettore OTIS 6104-7039 (carbone)
K3	Selettore OTIS 9558 12 fermate
K4	Contatto selettore OTIS 6104-7039 con carbone
K4/1	Contatto selettore OTIS 6104-7039 metallo
K5	Contatto selettore OTIS Buma
K6	Camma 327 FT2 a doppia pista per selettori OTIS 6850-9850
K7	Camma 327 a pista singola
K8	Selettore OTIS 12 contatti 125 V
K8/1	Selettore OTIS 24 contatti 60 V

RICAMBI SELETTORE OTIS SPARE PARTS SELECTOR OTIS

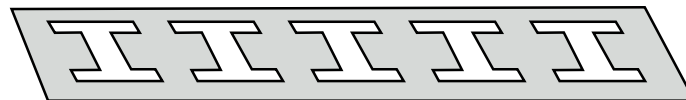

K23

Codice / Code	Descrizione
K23	Nastro per selettore lunghezza 50
K23/1	Nastro per selettore lunghezza 100
K23/2	Nastro per selettore lunghezza 135
K23/3	Nastro per selettore lunghezza 200
K23/4	Nastro per selettore lunghezza 250
K24	Ruota grande dentata per selettore
K25	Pignone piccolo per catena per selettore OTIS 7039

NOTE

CASSETTE PORTA CHIAVI E PORTA DOCUMENTI IN VETRO E CIECHE
KEY AND DOCUMENT HOLDER IN GLASS AND BLIND

Cassette porta chiavi - cassetta porta documenti 26.2
Key Holder Box - Document Holder

TARGHE
PLATES

Targhe spingere 26.7
Push plates

Targhe varie (vedi testi) 26.3-26.4-26.5-26.6
Various plates (see text)

Note: I componenti sul catalogo con riportata una specifica marca di ascensore sono utilizzati abitualmente solo da questa marca. I particolari senza marca sono utilizzati da più marche di ascensori.

Note: *The components in the catalogue with a specific lift brand are usually used only by the brand. Unbranded parts are used by multiple lift brands.*

CASSETTA PORTA CHIAVI E CASSETTA PORTA DOCUMENTI KEY HOLDER BOX AND DOCUMENT HOLDER



530



530/1



531



530

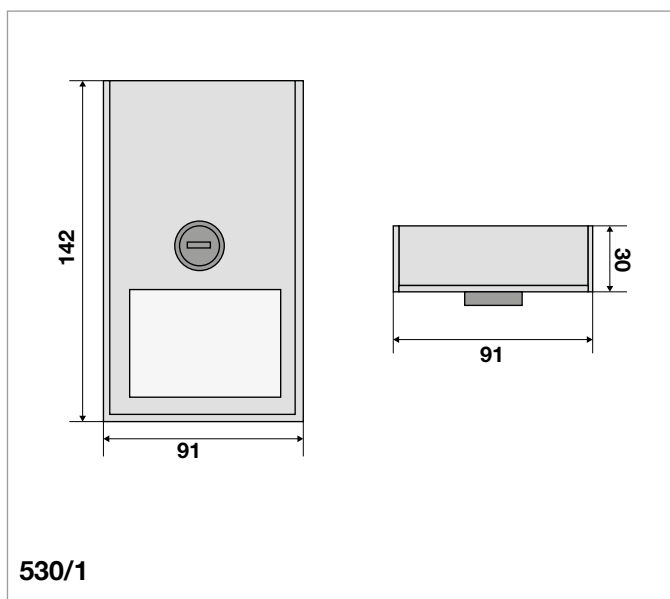

530/1



531

Codice / Code	Descrizione
530	Cassetta porta chiavi senza vetro - chiave 9225
530/1	Cassetta porta chiavi con vetro - chiave 9225
531	Cassetta porta documenti

TARGHE
A richiesta con le seguenti scritte:

- * FERMO PER MANUTENZIONE
- * CARATTERISTICHE FUNI
- * PORTATA - CAPIENZA
- * E' VIETATO L'USO DELL'ASCENSORE A MINORI DI _____
- * PORTATA _____ PERSONA INCLUSA
- * FUORI SERVIZIO
- * PORTATA _____ CAPIENZA _____ IMPIANTO N° _____
- * PORTATA _____ CAPIENZA _____ IMPIANTO N° _____ MATR. N° _____
- * VIETATO FUMARE
- * ACCOMPAGNARE LA PORTA
- * PORTATA 24 KG
- * ATTENZIONE NON AVVICINARE MANI O PIEDI
- * FISSARE I CARICHI MOBILI
- * MANOVRA A MANO FUNI E/O OLEODINAMICO
- * ARRESTO SUP. ALLE 14 ORE
- * DIVIETO ACCESSO
- * PIASTRA SPINGERE
- * ALTRE TARGHE SU RICHIESTA

TARGHE PLATES

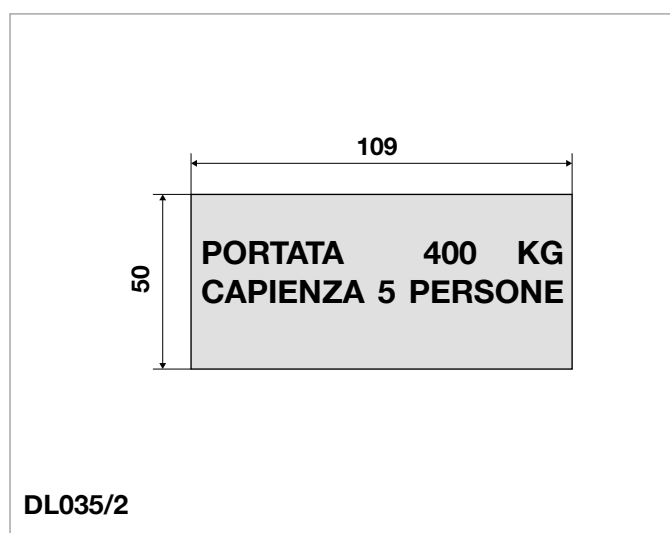
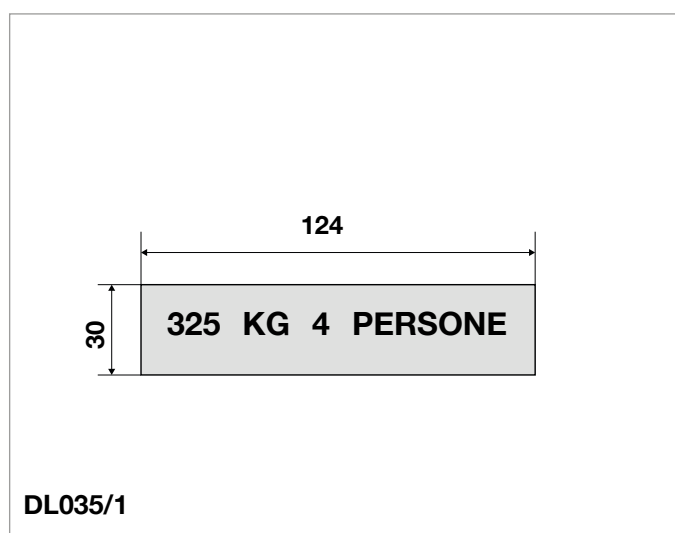
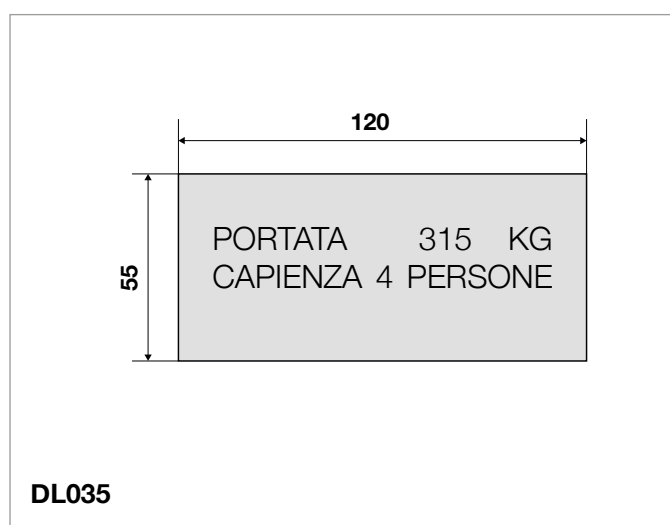
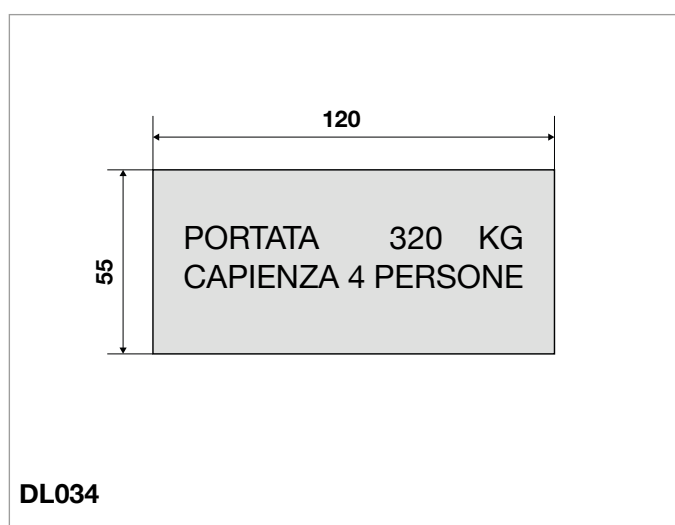

26

Codice / Code	Descrizione
DL034	Targa PORTATA 320 KG. CAPIENZA 4 PERSONE (adesiva)
DL035	Targa PORTATA 315 KG. CAPIENZA 4 PERSONE (adesiva)
DL035/1	Targa PORTATA 325 KG. CAPIENZA 4 PERSONE (adesiva)
DL035/2	Targa PORTATA 400 KG. CAPIENZA 4 PERSONE (adesiva)

TARGHE PLATES



DL036



DL037



DL038



DL042

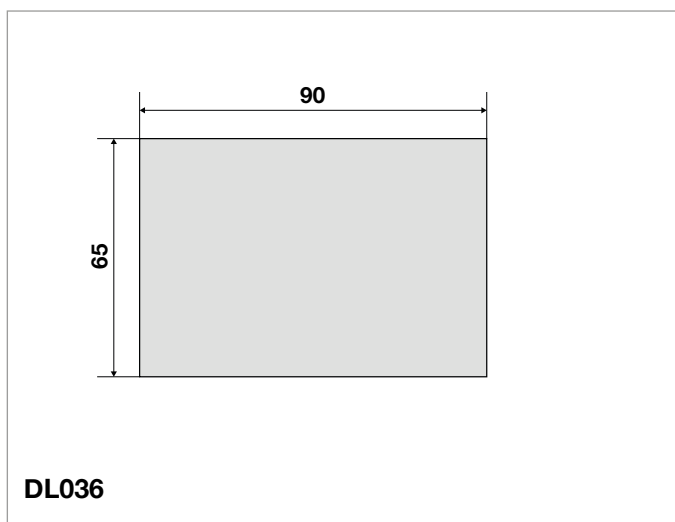

DL036

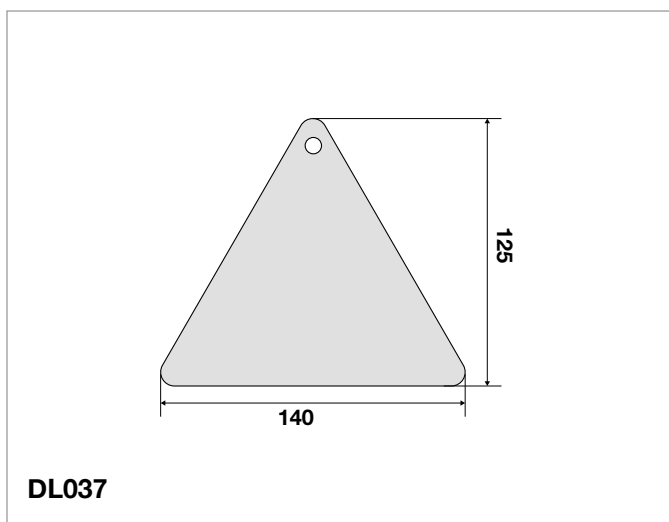

DL037

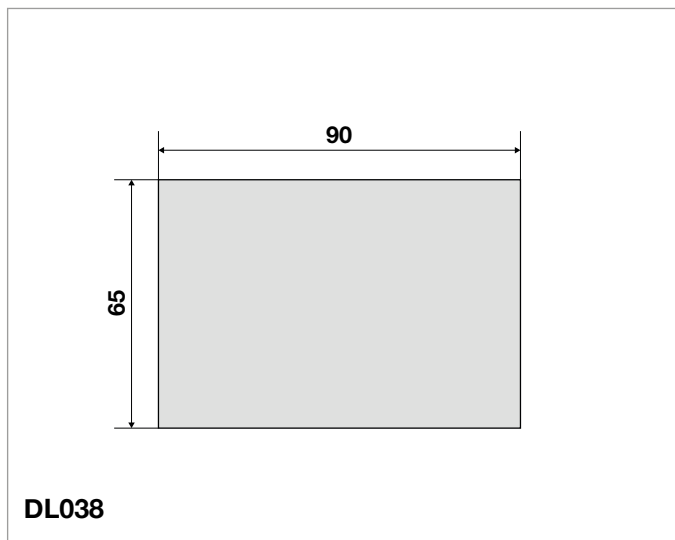

DL038

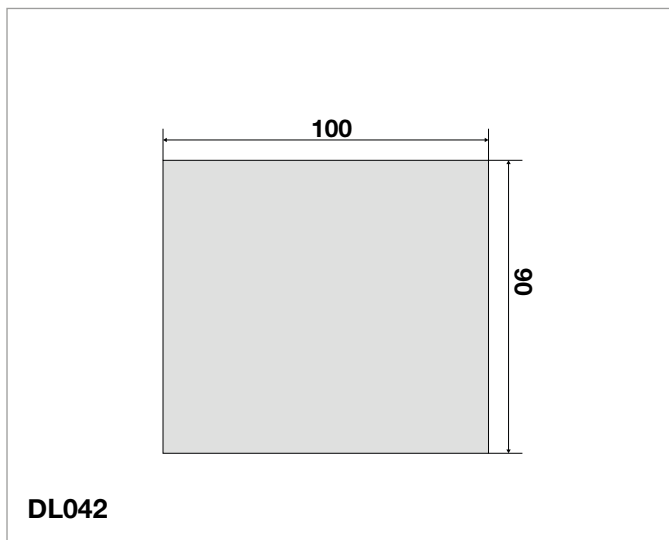

DL042

Codice / Code	Descrizione
DL036	Targa I.S.P.E.S.L.
DL037	Targa FUORI SERVIZIO/FERMO PER MANUTENZIONE
DL038	Targa E.N.P.I.
DL042	Targa MINISTERO DEL LAVORO

TARGHE PLATES



DL045



DL046



DL047



DL049



DL050

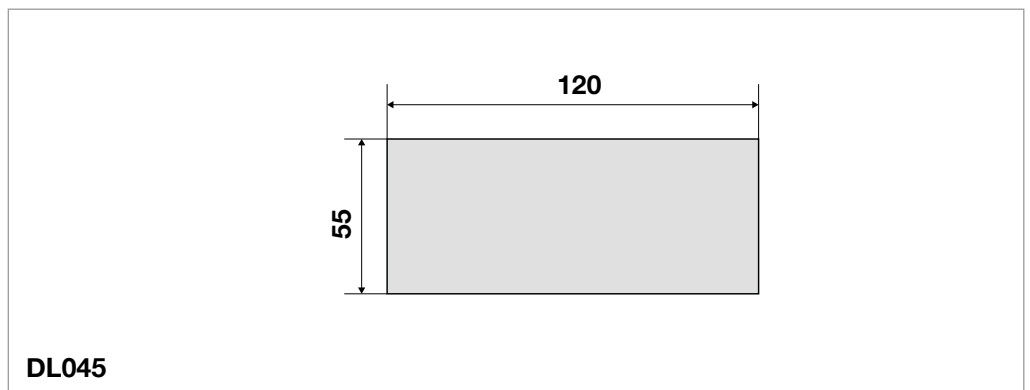

DL045

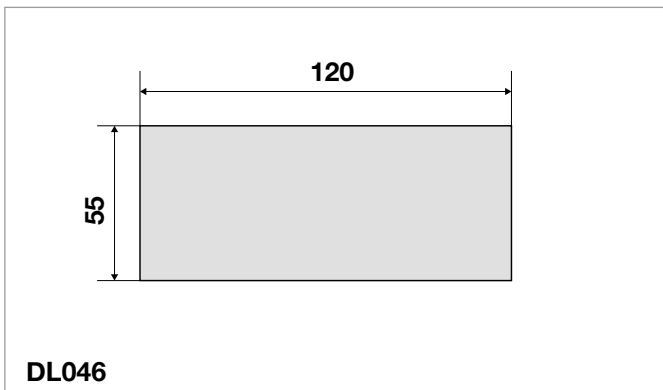

DL046

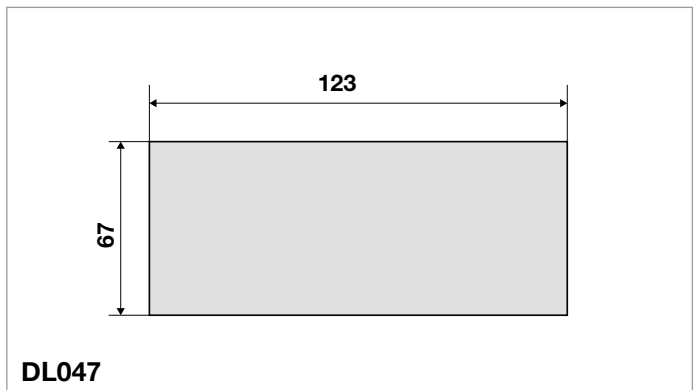

DL047

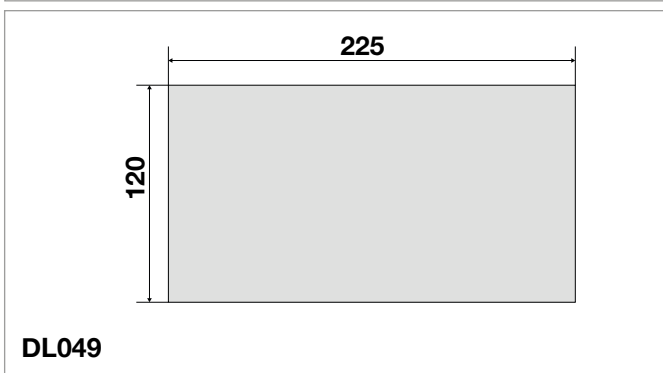

DL049

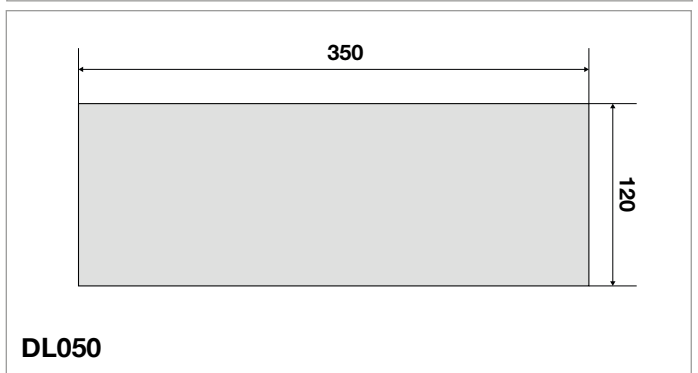

DL050

Codice / Code	Descrizione
DL045	Targa VIETATO L'USO DELL'ASCENSORE AI MINORI ANNI 12
DL046	Targa ARRESTO SUPERIORE ALLE 14 ORE
DL047	Targa VIETATO FUMARE LEGGE 16/01/03 N.3 ART.51
DL049	Targa DI PRESCRIZIONE
DL050	Targa DIVIETO DI ACCESSO

TARGHE PLATES

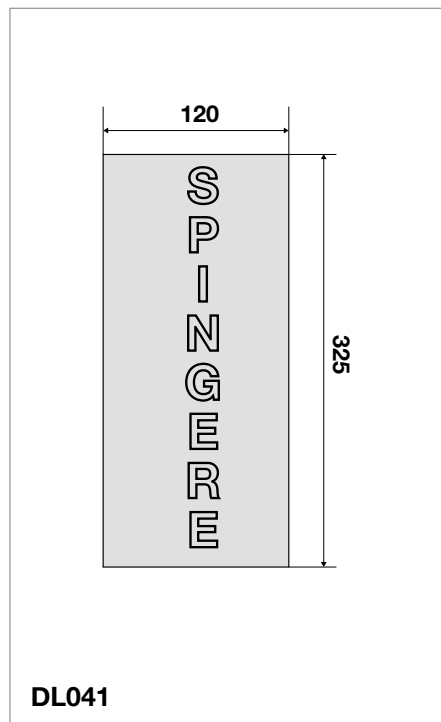
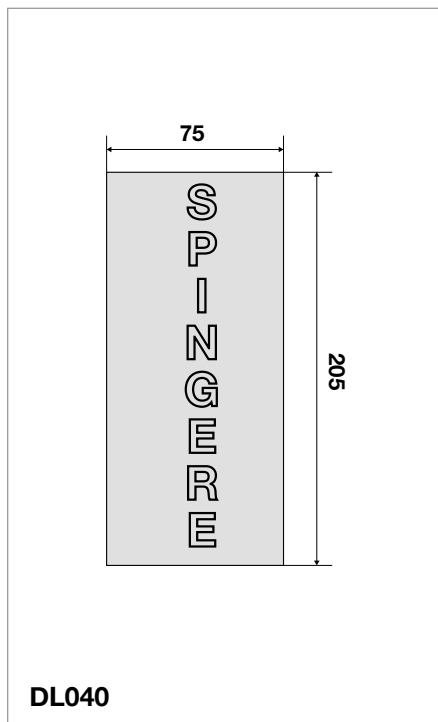
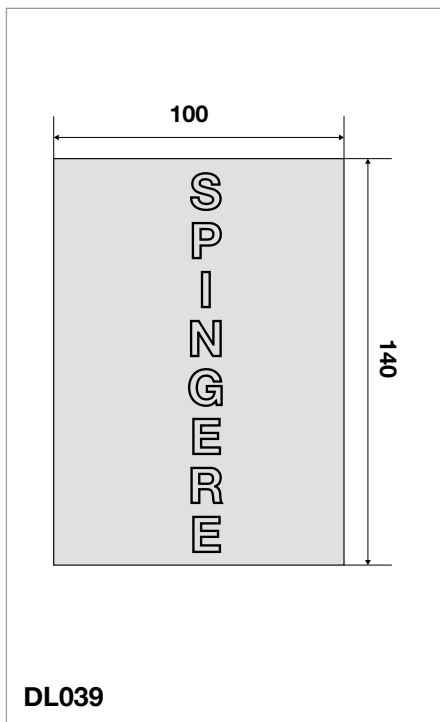
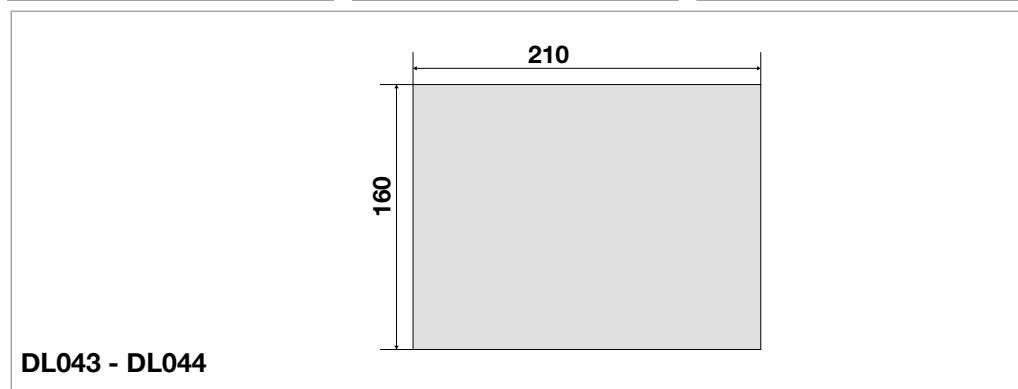

Codice / Code	Descrizione
DL039	Targa SPINGERE 100 x 140 mm
DL040	Targa SPINGERE 75 x 205 mm
DL041	Targa SPINGERE 120 x 325 mm
DL043	Targa IMPIANTO OLEODINAMICO ISTRUZIONI MANOVRA A MANO
DL044	Targa IMPIANTO A FUNI ISTRUZIONI MANOVRA A MANO

NOTE

GIUNTI IN GOMMA

SUPPORT

Giunti in gomma argano SCHINDLER e FIAM	27.12 - 27.13
<i>Flexible motor coupling in rubber for SCHINDLER and FIAM</i>	

SUPPORTI

SUPPORT

Supporti in gomma per cabine con e senza fondo mobile FIAM e generici	27.11
<i>Rubber support for cabin door with or without movable bottom FIAM and general</i>	

TAMPONI IN GOMMA E TAMPONI VARI

RUBBER PADS AND VARIOUS PADS

Rotella gomma sospensione FIAM A/280	27.6
<i>Rubber roller hanger FIAM A/280</i>	

Supporti antivibranti per porte di piano a battente FIAMM	27.8
<i>Anti-Vibration supports for leaf doors FIAMM</i>	

Tampone di battuta porte automatiche FIAM	27.7
<i>Stop buffer for automatic door FIAM</i>	

Tampone in gomma per asta automatismo FIAM A/2PO	27.6
<i>Rubber pad for automatism rod FIAM A/2PO</i>	

Tampone registro carrello sospensione automatismo FIAM A/2PO.....	27.6
<i>Adjuster stop rubber pad for hanger automatism FIAM A/2PO</i>	

Tamponi con perno FIAM	27.7
<i>Pad with pivot FIAM</i>	

Tamponi di arresto operatore OTIS, automatismo sospensione FIAM	27.4
<i>Stop rubber for OTIS operator, automatism hanger FIAM</i>	

Tamponi di fermo con vite porte automatiche FIAM	27.7
<i>Stop pad with screws for automatic door FIAM</i>	

Tampone di fermo leva MR041 per automatismo FIAM A/2PO	27.6
<i>Rubber pads stop lever MR041 for automatism FIAM A/2PO</i>	

Tamponi in gomma antivibranti rettangolari e bussole in gomma e di registro sospensioni automatismi FIAM 27.5

Anti-Vibration rubber pad in rectangular and bush in rubber and hanger adjuster for automatism FIAM

Tamponi in gomma per abbinamento porte automatiche STANDARD - AKRON - BASSETTI - FIAM - SABIEM 27.3

Rubber pads for coupling automatic doors STANDARD - AKRON - BASSETTI - FIAM - SABIEM

Tamponi in gomma per porte semiautomatiche FIAM - BASSETTI vecchio 27.10

Rubber pads for semi-automatic doors FIAM - old BASSETTI

Tamponi in gomma per portine di piano semiautomatiche TIEFFE - VICINI - BASSETTI 27.9

Rubber pads for semi-automatic landing doors TIEFFE - VICINI - BASSETTI

27

Note: I componenti sul catalogo con riportata una specifica marca di ascensore sono utilizzati abitualmente solo da questa marca. I particolari senza marca sono utilizzati da più marche di ascensori.

Note: *The components in the catalogue with a specific lift brand are usually used only by the brand. Unbranded parts are used by multiple lift brands.*

TAMPONI IN GOMMA PER ABBINAMENTO PORTE AUTOMATICHE FIAM - BASSETTI - SABIEM - AKRON
RUBBER PADS FOR COUPLING AUTOMATIC DOOR FIAM - BASSETTI - SABIEM - AKRON

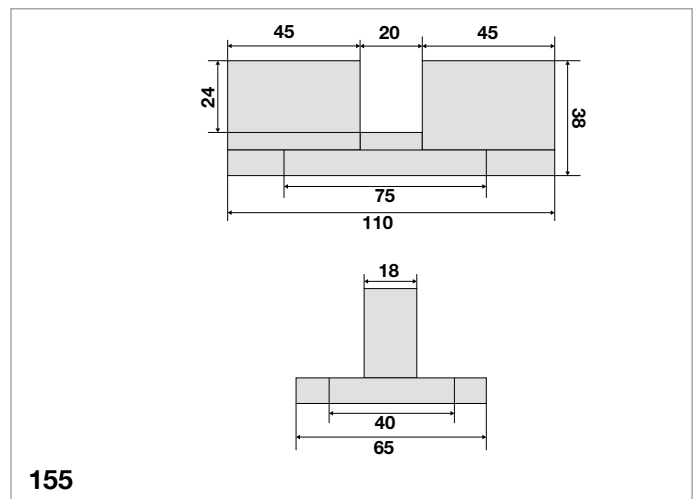
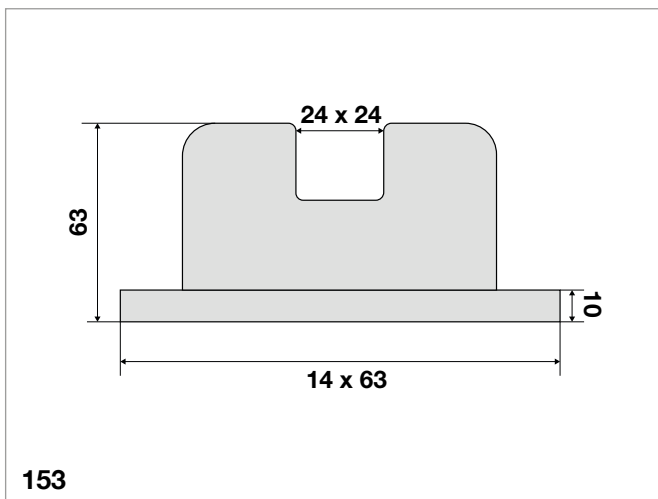
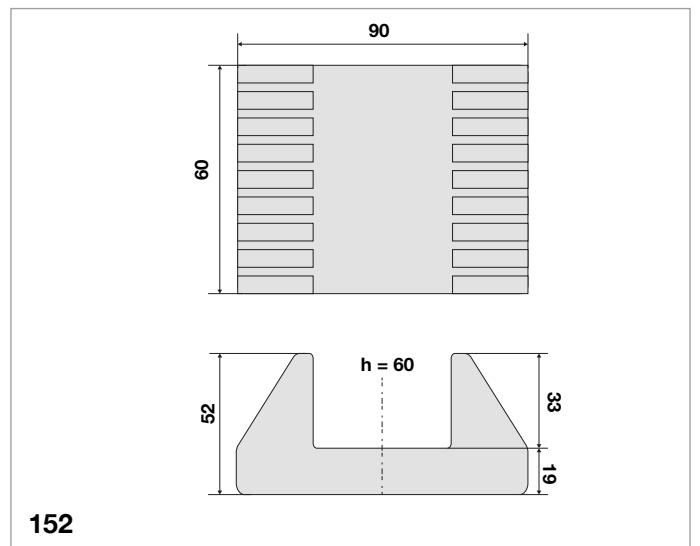
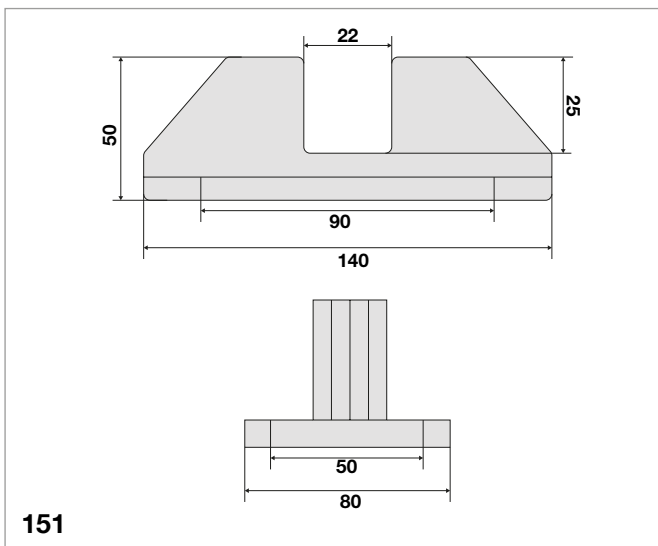

Codice / Code	Descrizione
151	Tampone in gomma per porte automatiche tipo "S" FIAM
152	Tampone in gomma per porte automatiche standard e BASSETTI
153	Tampone in gomma per porte automatiche SABIEM
155	Tampone in gomma per porte automatiche AKRON

TAMPONI ARRESTO OPERATORE OTIS E FIAM STOP PADS FOR OTIS AND FIAM OPERATOR

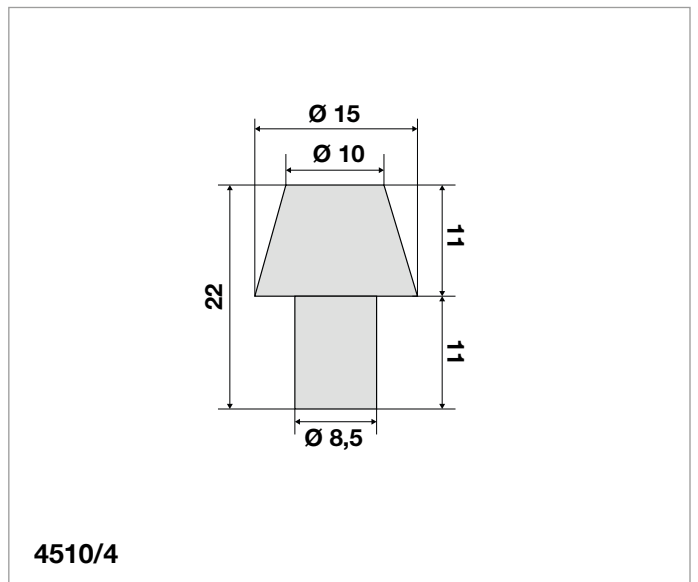
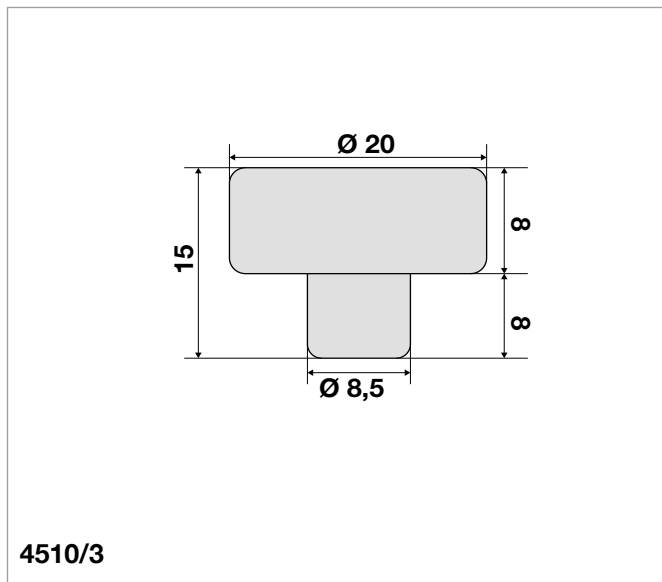
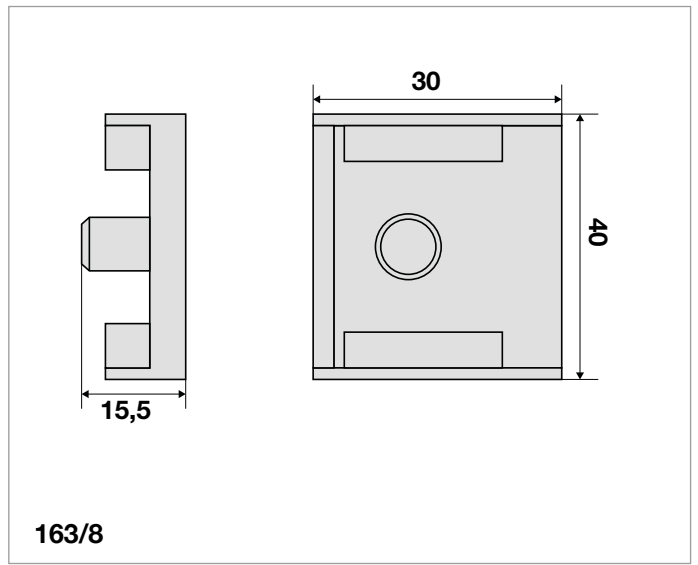
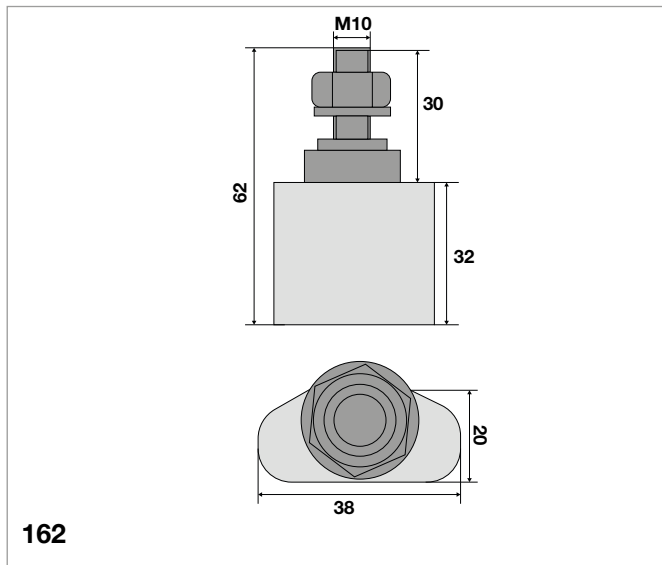

Codice / Code	Descrizione
162	Tampone arresto settore operatore OTIS
163/8	Tampone automatismo sospensione FIAM A/2PO
4510/3	Tampone gomma di caduta pattino elettromagnetico LG47
4510/4	Tampone gomma eccitazione pattino elettromagnetico LG47

TAMPONI IN GOMMA RUBBER PADS

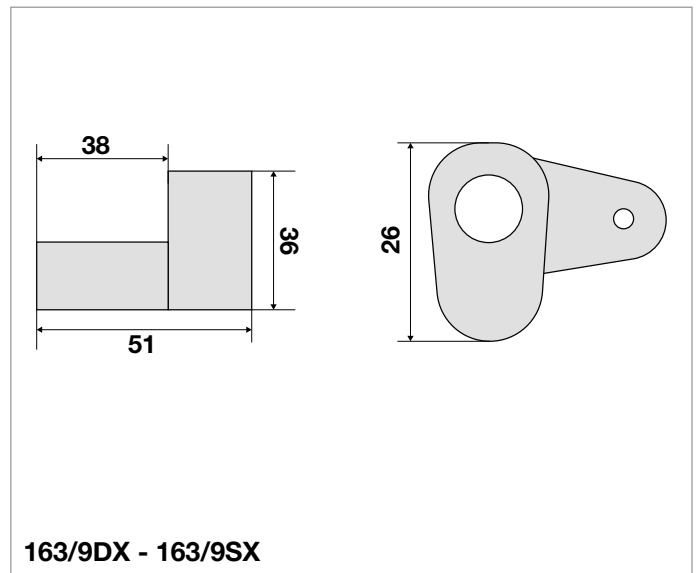
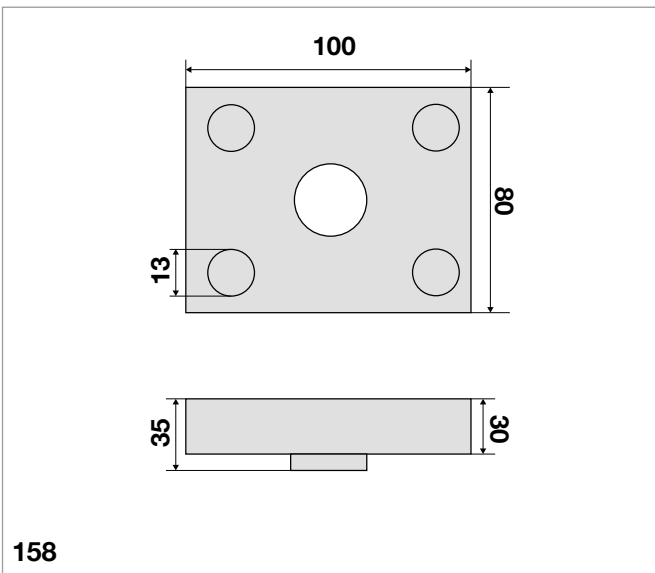
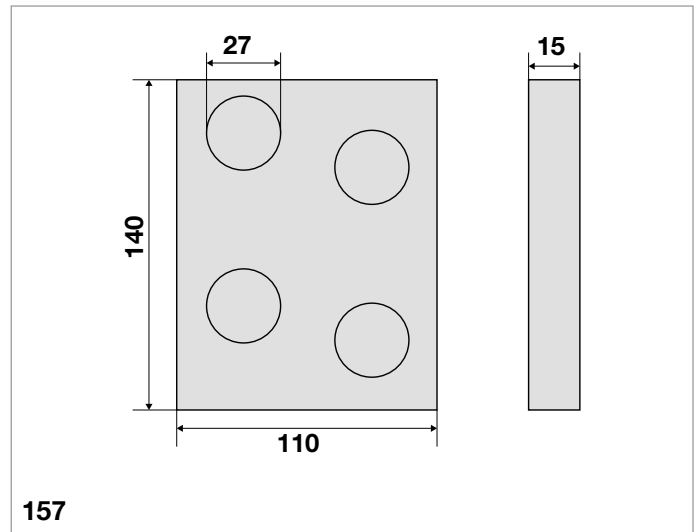
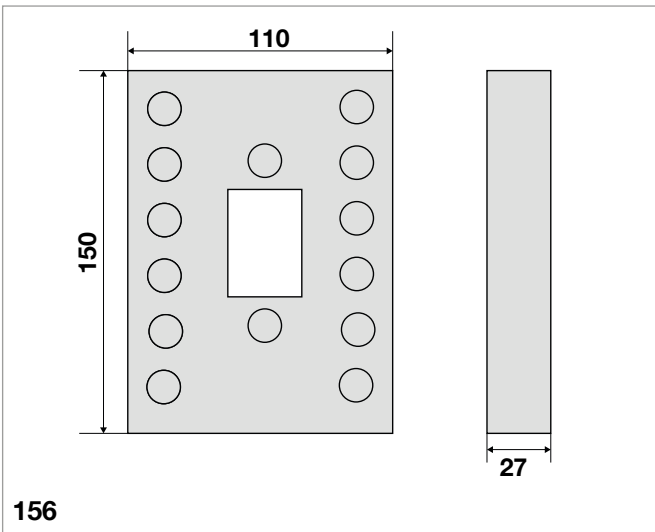
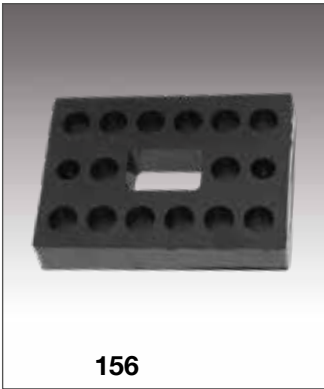

Codice / Code	Descrizione
156	Tampone antivibrante 110 x 150 x 27 a 16 fori + 1 foro quadrato FIAM portata 500 kg
157	Tampone antivibrante 140 x 110 x 15 a 4 fori per piastra attacco funi cabina
158	Tampone antivibrante 100 x 80 x 30 a 4 fori + 1 foro tondo FIAM portata 500 kg
163/9DX	Bussole gomma arresto leva FIAM per carrello DX
163/9SX	Bussole gomma arresto leva FIAM per carrello SX

TAMPONI IN GOMMA FIAM RUBBER PADS FIAM

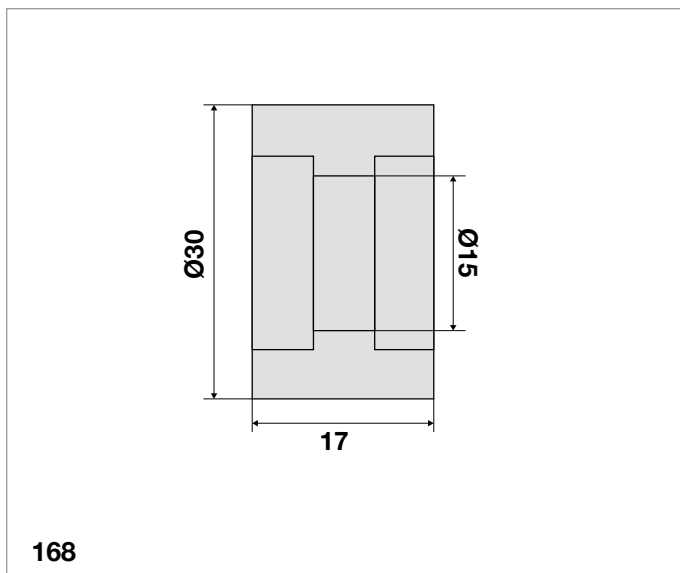
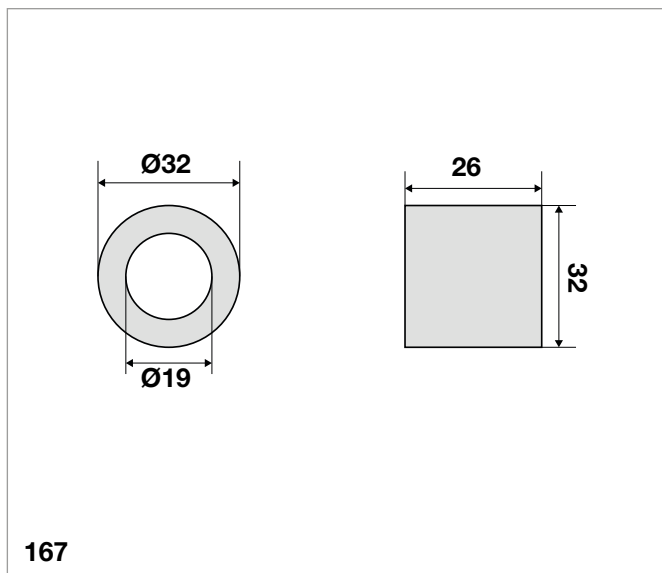
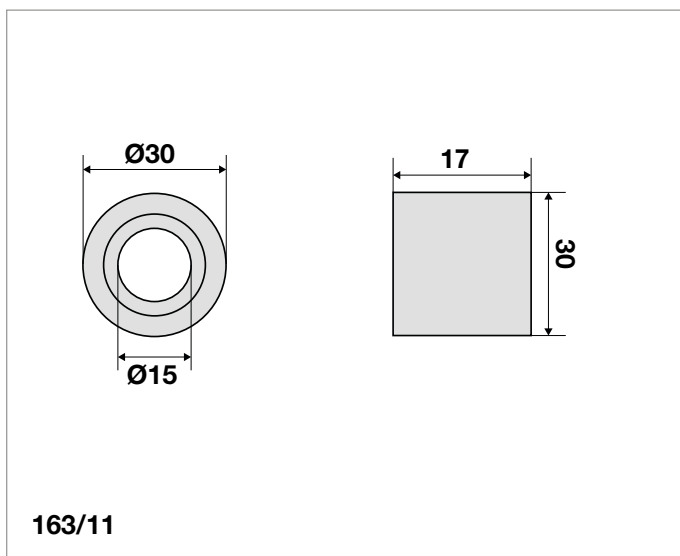
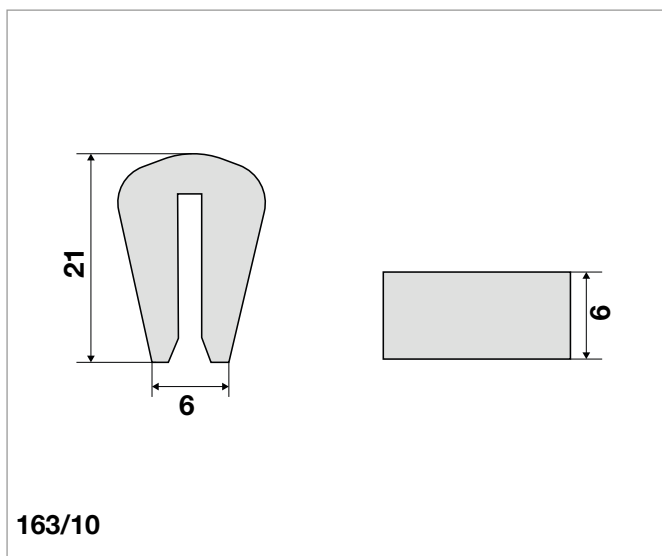
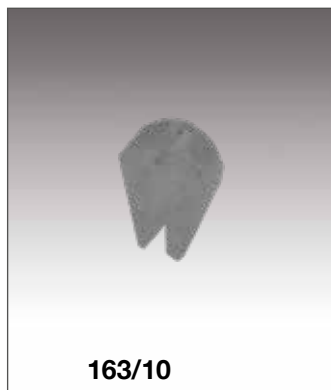

27

Codice / Code	Descrizione
163/10	Tampone registro carrello sospensione automatismo "A" FIAM
163/11	Tampone in gomma asta biella automatismo A/2PO FIAM
167	Tampone di fermo leva MR 041 FIAM
168	Rotella gomma sospensione A/2PO FIAM

TAMPONI IN GOMMA RUBBER PADS

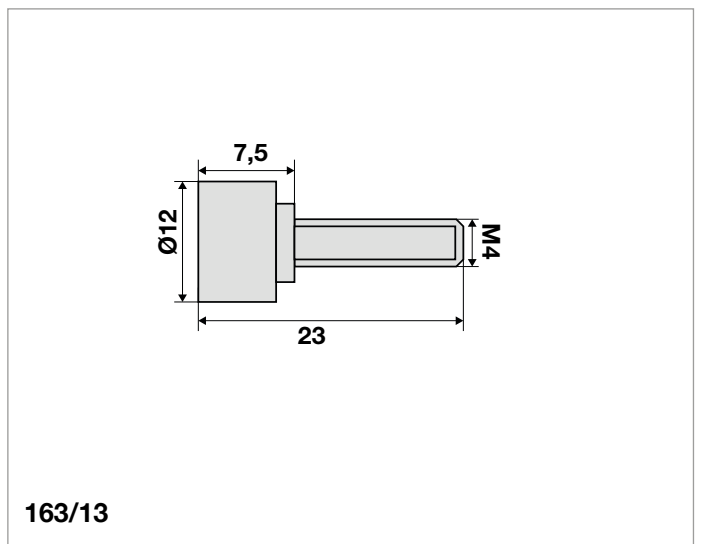
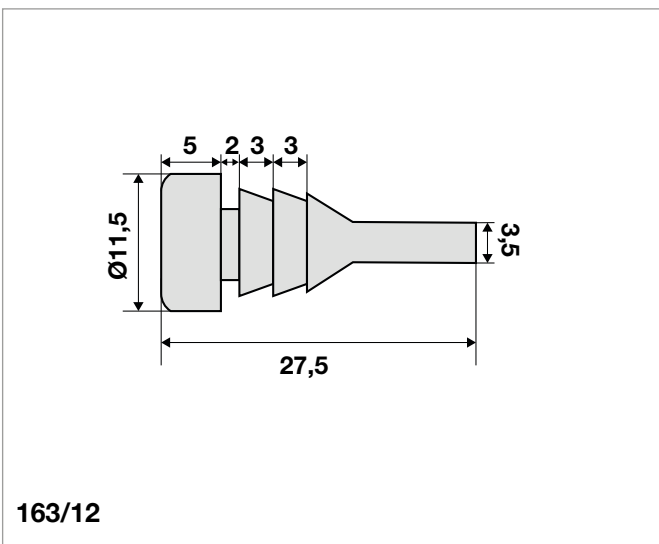
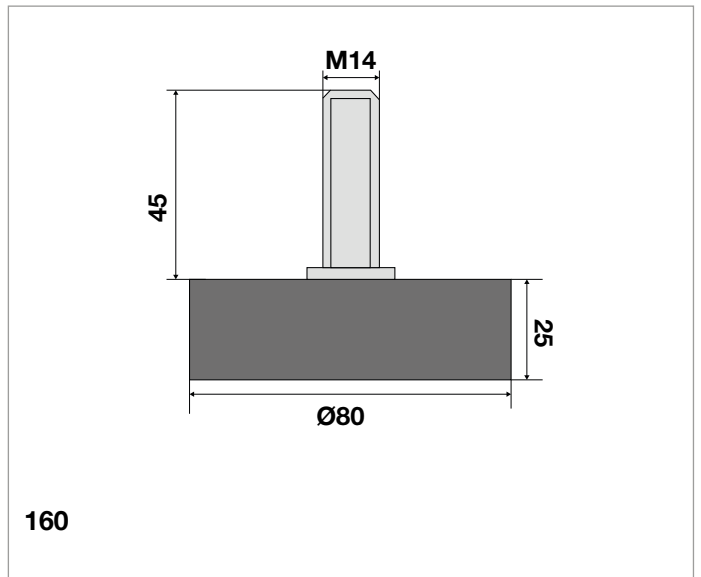
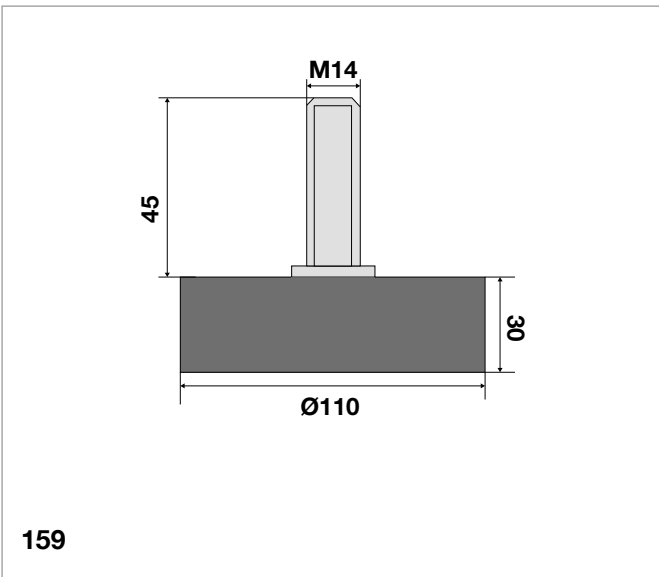
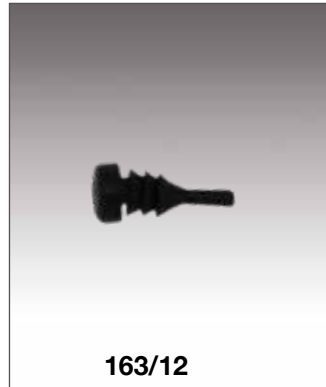

Codice / Code	Descrizione
159	Tampone d. 110 x 30 perno M14 x 45 FIAM
160	Tampone d. 80 x 25 perno M14 x 45 FIAM
163/12	Tampone di battuta porte automatiche FIAM
163/13	Tampone di fermo con vite porte automatiche FIAM

SUPPORTI ANTIVIBRANTI ANTI-VIBRATION SUPPORTS

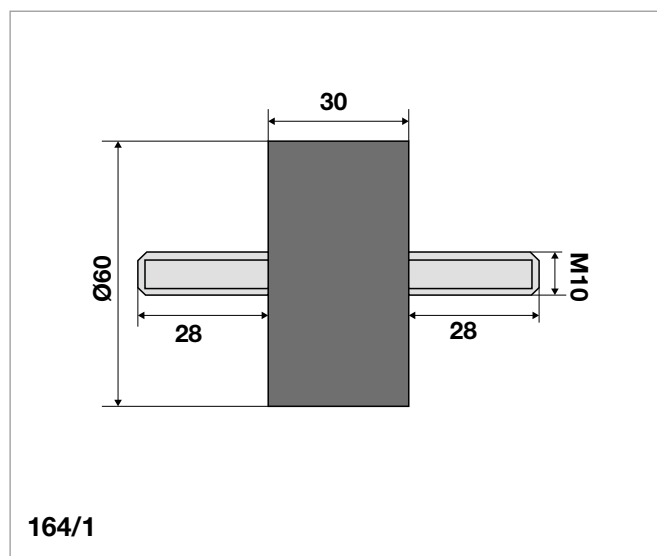
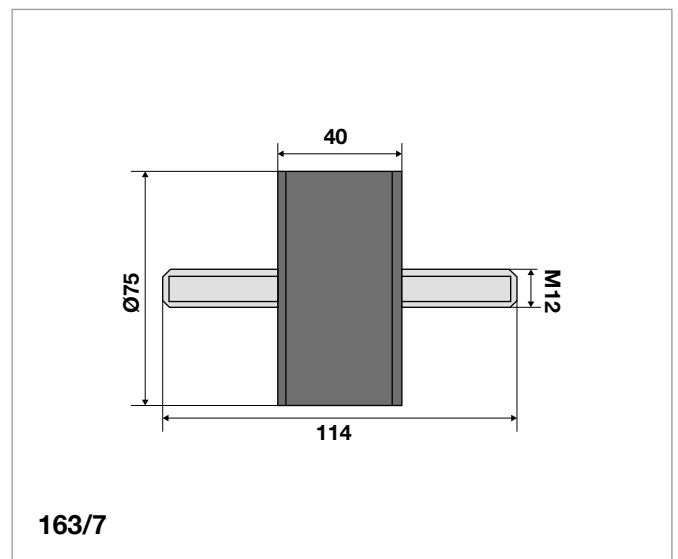
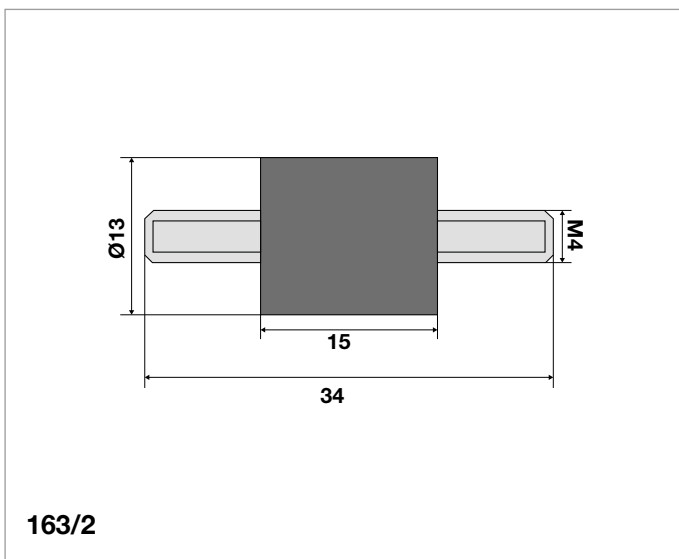

27

Codice / Code	Descrizione
163/2	Supporto antivibrante M4 15 x 5 FIAM
163/7	Supporto antivibrante M12 75 x 40 FIAM
164/1	Supporto antivibrante M10 x 28 x 28 d. 60x30

TAMPONI IN GOMMA PER PORTE DI PIANO SEMIAUTOMATICHE TIEFFE VICINI - BASSETTI
RUBBER PAD FOR SEMIAUTOMATIC LEAF DOOR TIEFFE - VICINI - BASSETTI

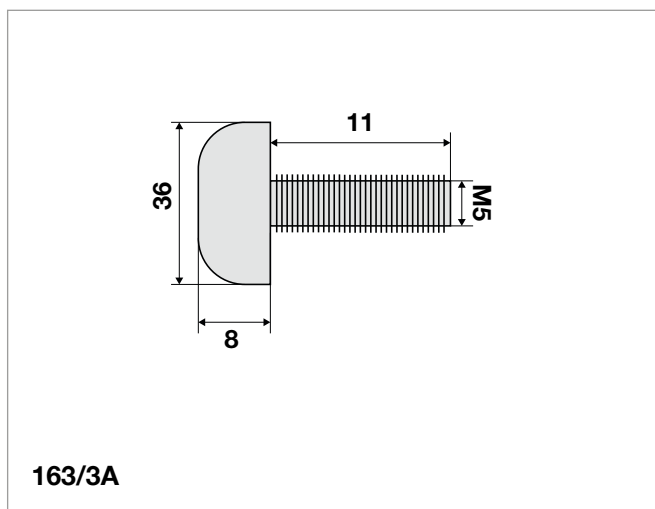
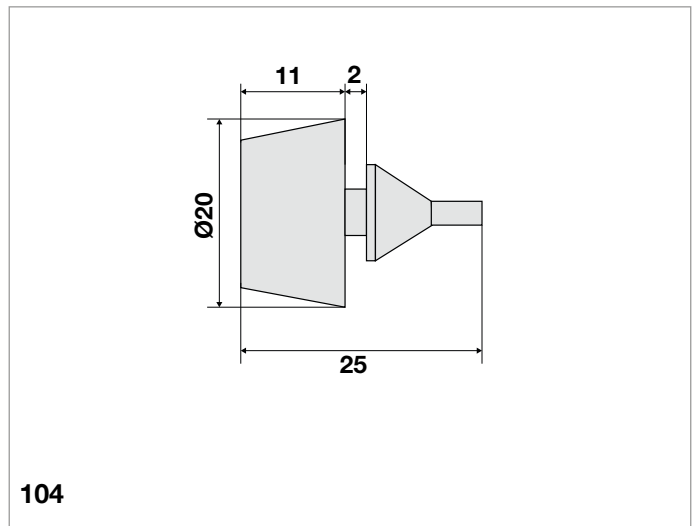
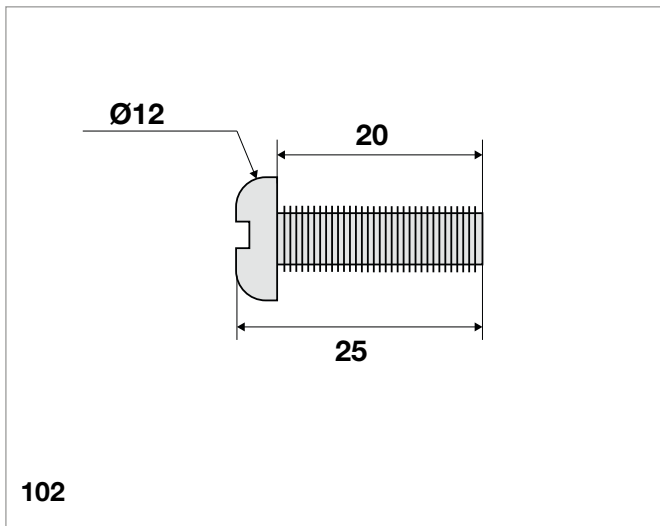
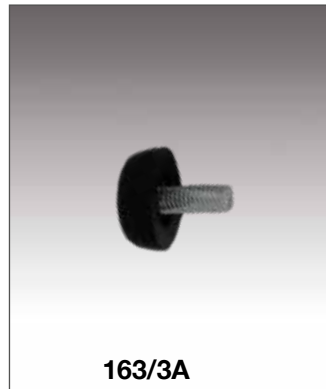
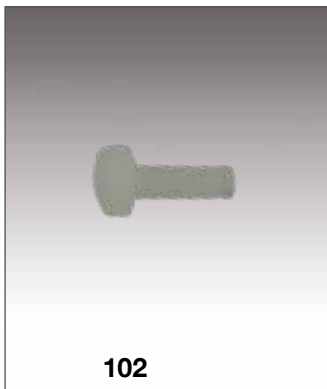

Codice / Code	Descrizione
102	Gommino paracolpi in nylon con taglio cacciavite porta TIEFFE
104	Gommino paracolpi porta semiautomatica BASSETTI
163/3A	Gommino paracolpi porta VICINI

TAMPONI IN GOMMA PER PORTE DI PIANO SEMIAUTOMATICHE - FIAM-BASSETTI
RUBBER PAD FOR SEMIAUTOMATIC LEAF DOOR FIAM - BASSETTI

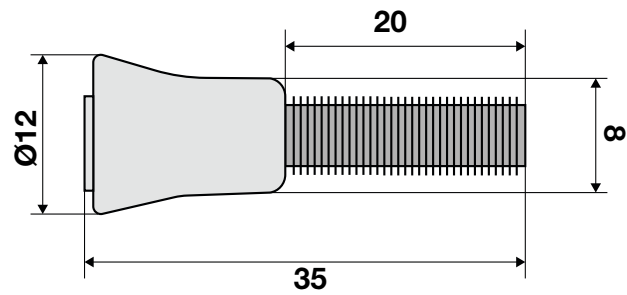
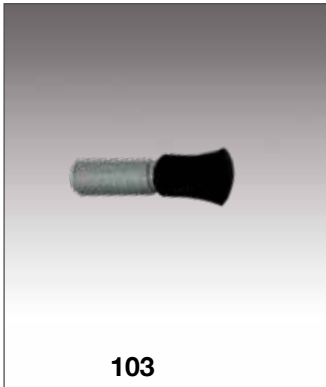

103

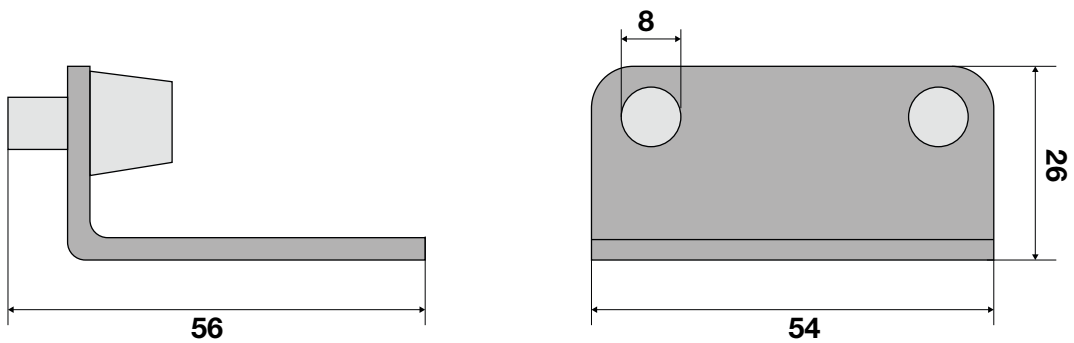

163/14

Codice / Code	Descrizione
103	Tampone arresto porta BASSETTI vecchio
163/14	Squadretta superiore porta a battente NS1 FIAM

SUPPORTI IN GOMMA PER CABINE CON E SENZA FONDO MOBILE FIAM E GENERICI

RUBBER SUPPORT FOR CABIN DOOR WITH AND WITHOUT MOVABLE BOTTOM FIAM AND GENERIC

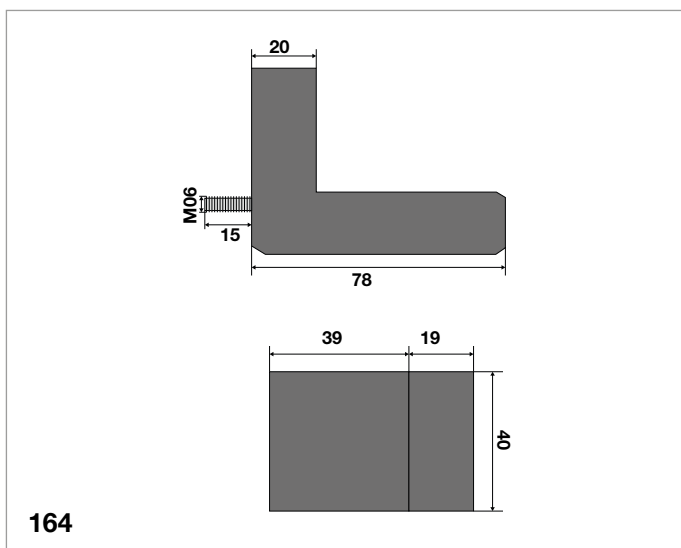
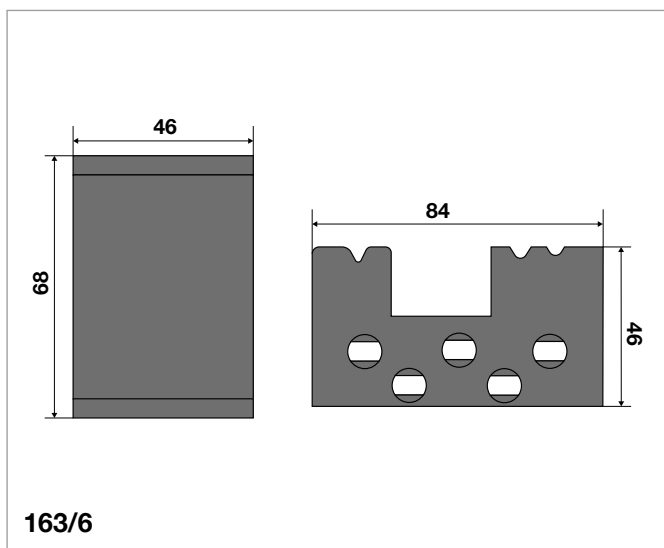
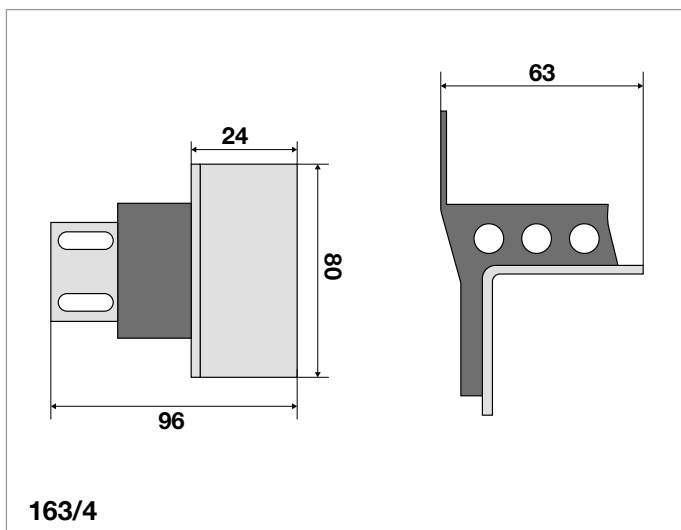
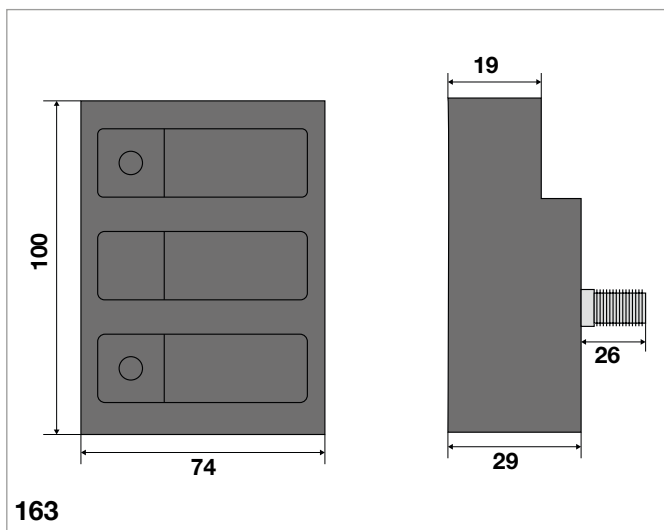
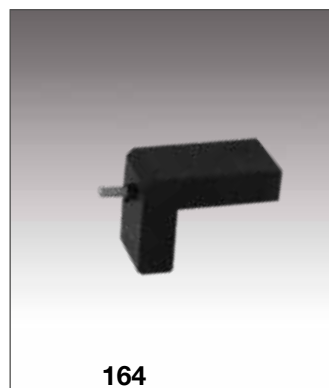
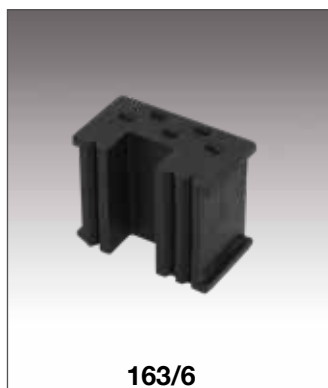
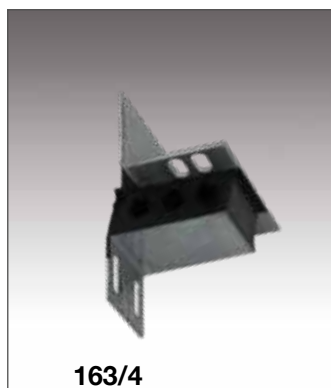

Codice / Code	Descrizione
163/4	Supporto elastico fondo mobile FIAM 15 Kg.
164	Tampone antivibrante perno M06 fissaggio sup. FIAM
163/6	Supporto antivibrante per quadro manovra
163	Tampone antibrante con perno M12 FIAM

GIUNTI IN GOMMA PER ARGANO SCHINDLER
FLEXIBLE MOTOR COUPLING IN RUBBER

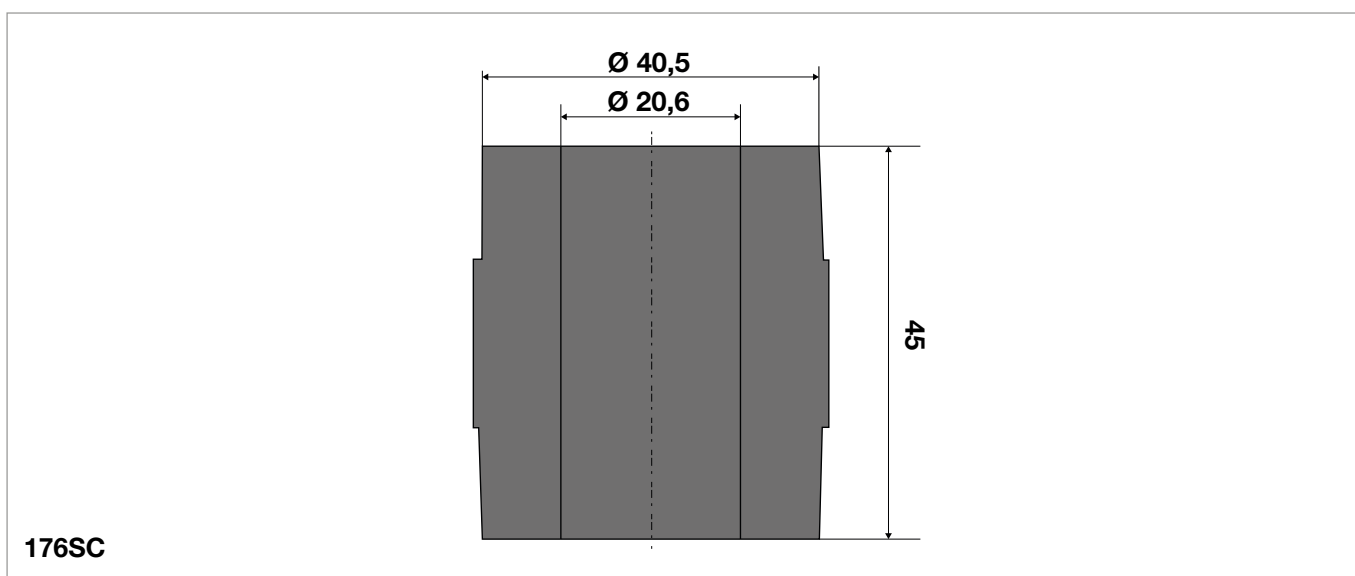
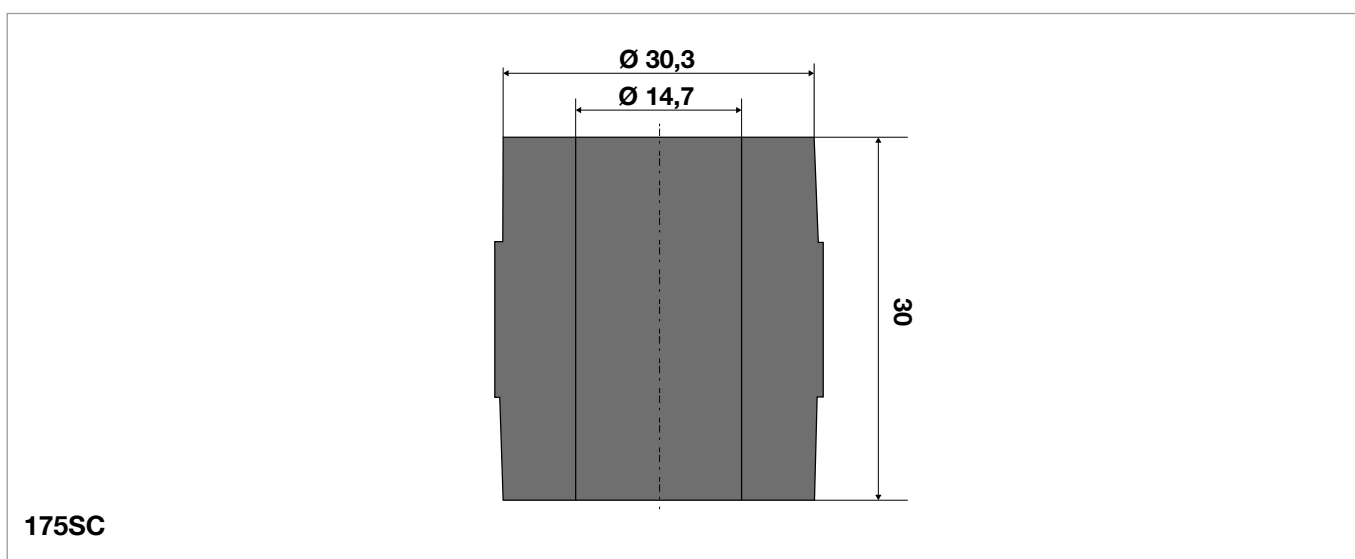

27

Codice / Code	Descrizione
175SC	Manicotto per giunto motore piccolo SCHINDLER
176SC	Manicotto per giunto motore grande SCHINDLER

SNODO PER GIUNTO ELASTICO ARGANO FIAM
FLEXIBLE MOTOR COUPLING IN ELASTIC FIAM

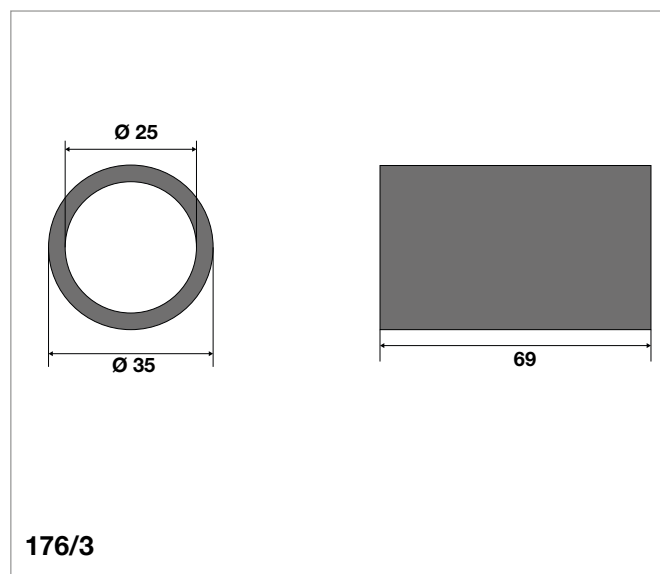
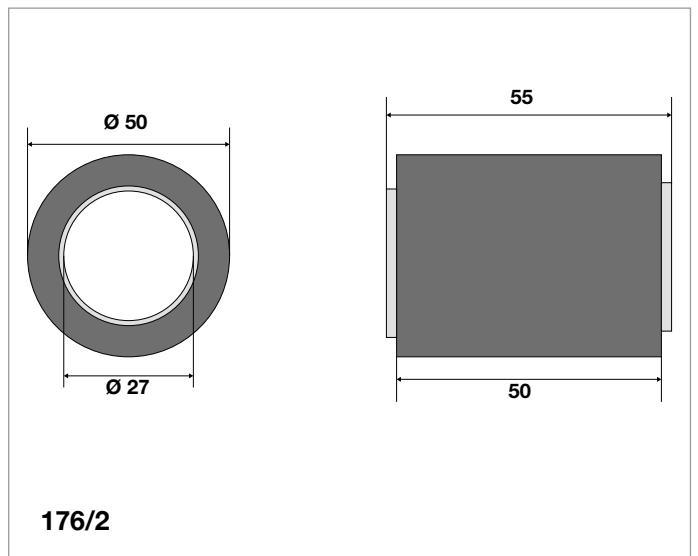
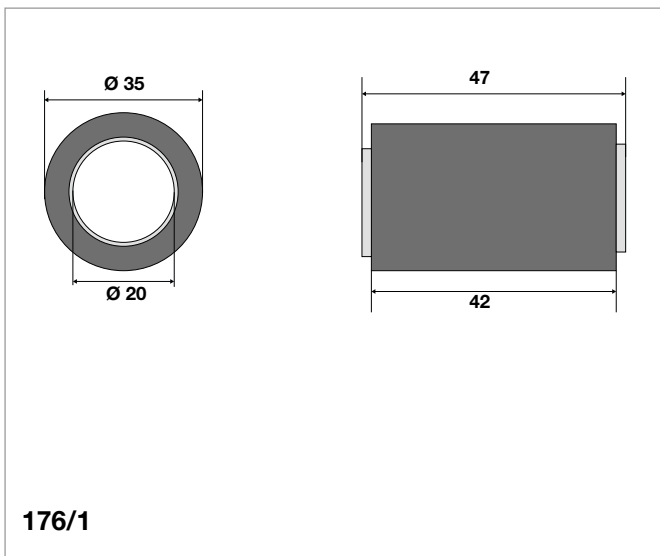

Codice / Code	Descrizione
176/1	Snodo elastico giunto per argano FIAM 3N - 5N
176/2	Snodo elastico giunto per argano FIAM 55 - 61 - 65
176/3	Snodo elastico giunto per argano FIAM 6N

NOTE

CHIAVI D'EMERGENZA
EMERGENCY KEYS

PORTA A BATTENTE
SWING DOORS

SCHINDLER 28.2

Standard 28.2

PORTA SCORREVOLE
SLIDING DOORS

FIAM 28.2

SCHINDLER 28.2

Note: I componenti sul catalogo con riportata una specifica marca di ascensore sono utilizzati abitualmente solo da questa marca. I particolari senza marca sono utilizzati da più marche di ascensori.

Note: The components in the catalogue with a specific lift brand are usually used only by the brand. Unbranded parts are used by multiple lift brands.

CHIAVI D'EMERGENZA EMERGENCY KEYS



926/26 926/27



936

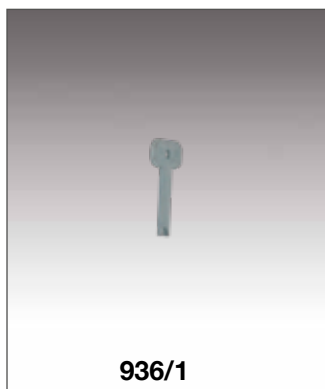

936/1



936/2

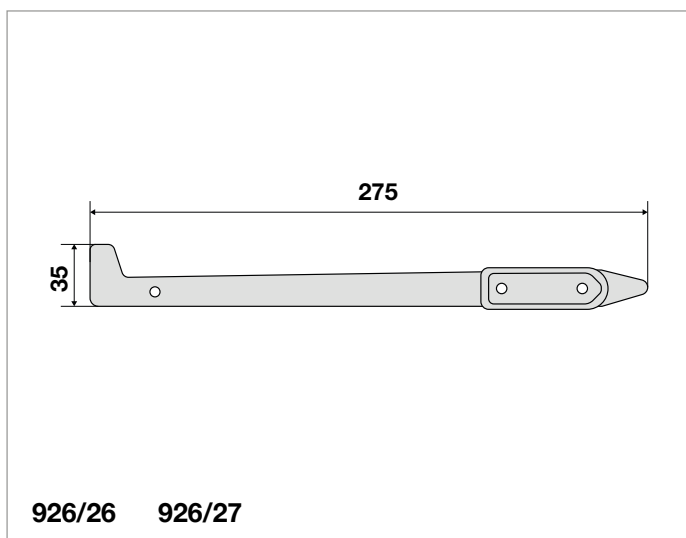

926/26 926/27

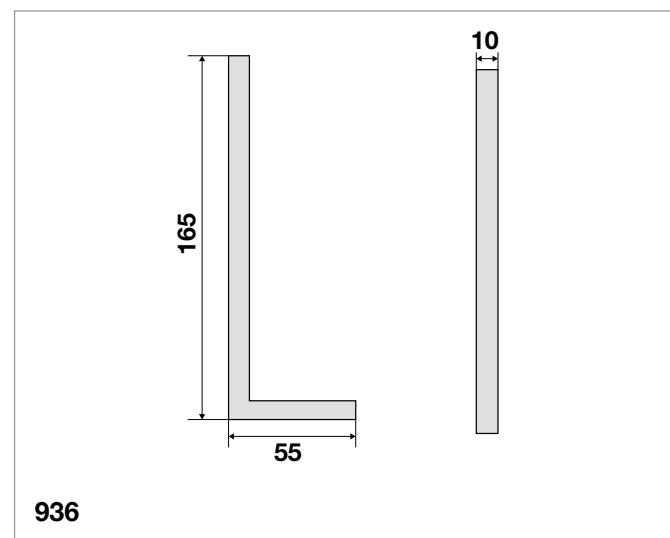

936

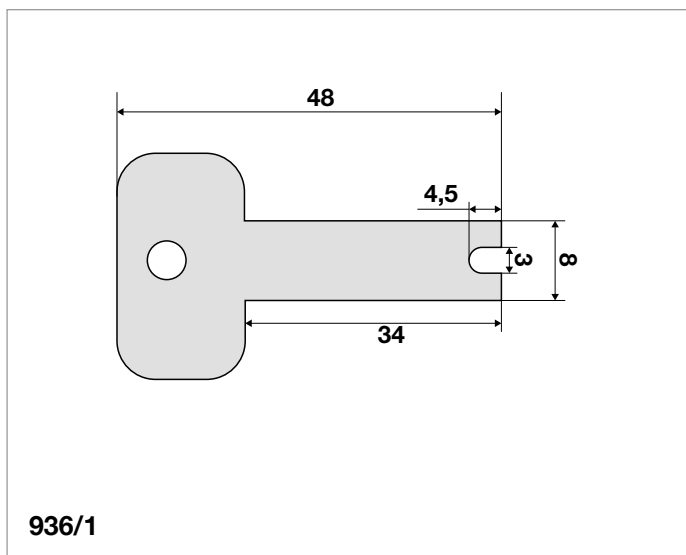

936/1

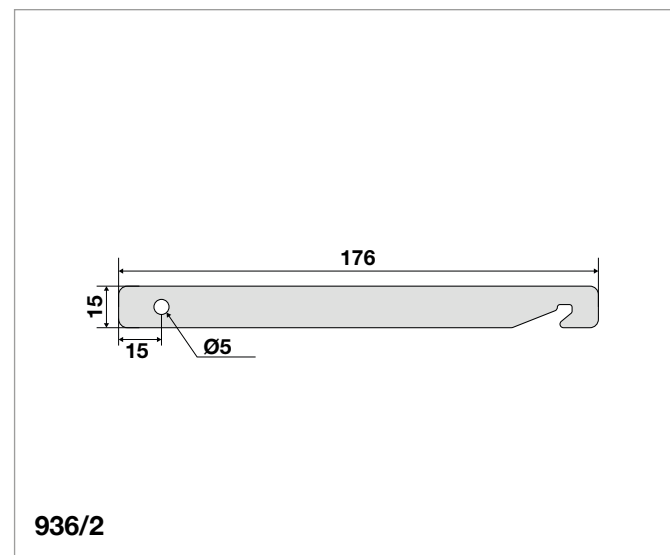

936/2

28

Codice / Code	Descrizione
926/26	Chiave emergenza chiusura FIAM SX
926/27	Chiave emergenza chiusura FIAM DX
936	Chiave emergenza standard triangolare
936/1	Chiave emergenza porta semiautomatica SCHINDLER
936/2	Chiave emergenza porta automatica SCHINDLER

RUOTE IN GOMMA PER LIMITATORI DI VELOCITÀ CON E SENZA CUSCINETTO
RUBBER ROLLER FOR OVERSPEED GOVERNOR WITH OR WITHOUT BEARING

Ruote in gomma per limitatore R1 - R3 29.2
Rubber roller for overspeed R1 - R3

Ruote in gomma per limitatore SCHINDLER - OTIS - FALCONI nuovo e vecchio 29.3
Rubber roller for overspeed SCHINDLER - OTIS - FALCONI new and old

Note: I componenti sul catalogo con riportata una specifica marca di ascensore sono utilizzati abitualmente solo da questa marca. I particolari senza marca sono utilizzati da più marche di ascensori.

Note: *The components in the catalogue with a specific lift brand are usually used only by the brand. Unbranded parts are used by multiple lift brands.*

RUOTE IN GOMMA PER LIMITATORI DI VELOCITÀ RUBBER ROLLER FOR OVERSPEED GOVERNOR

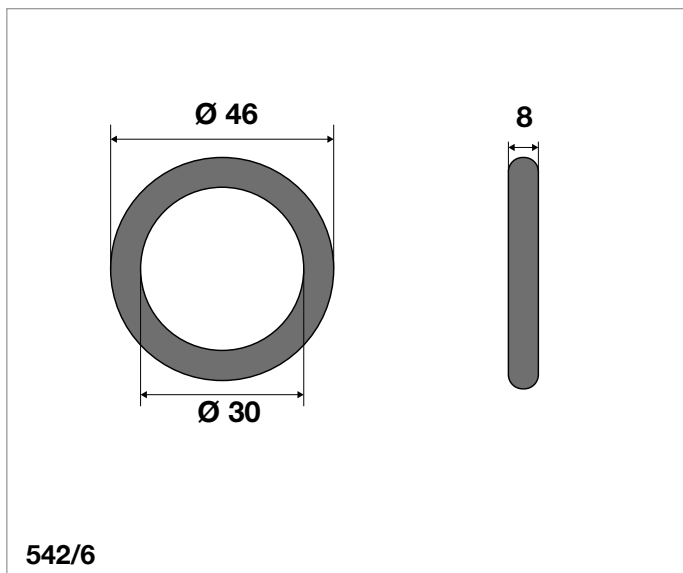
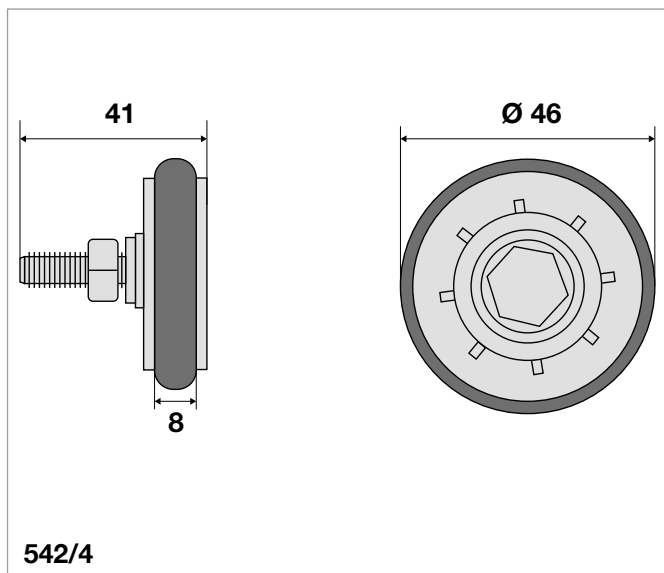
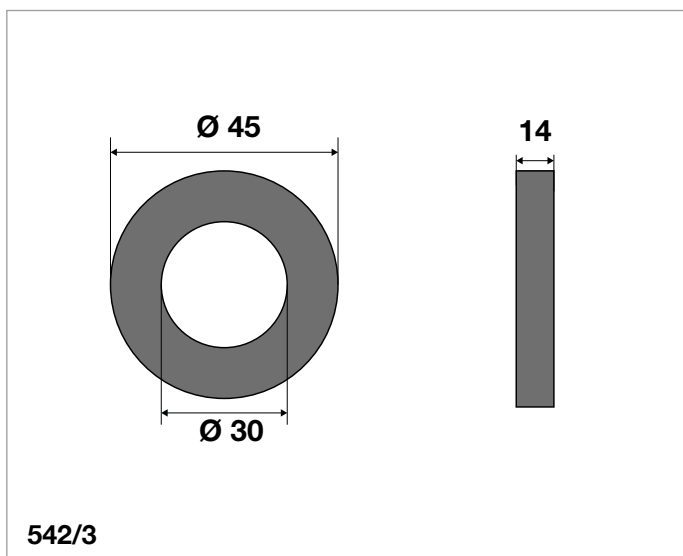
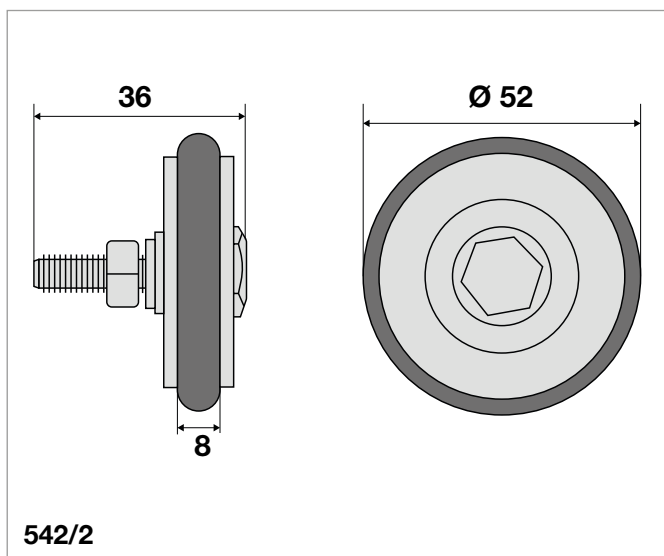

Codice / Code	Descrizione
542/2	Ruota in gomma + perno per limitatore R3 cod. 540
542/3	Solo ruota in gomma del cod. 542/2
542/4	Ruota in gomma + perno per limitatore R1 cod. 542/1
542/6	Solo ruota in gomma del cod. 542/4

RUOTE IN GOMMA PER LIMITATORI DI VELOCITÀ RUBBER ROLLER FOR OVERSPEED GOVERNOR

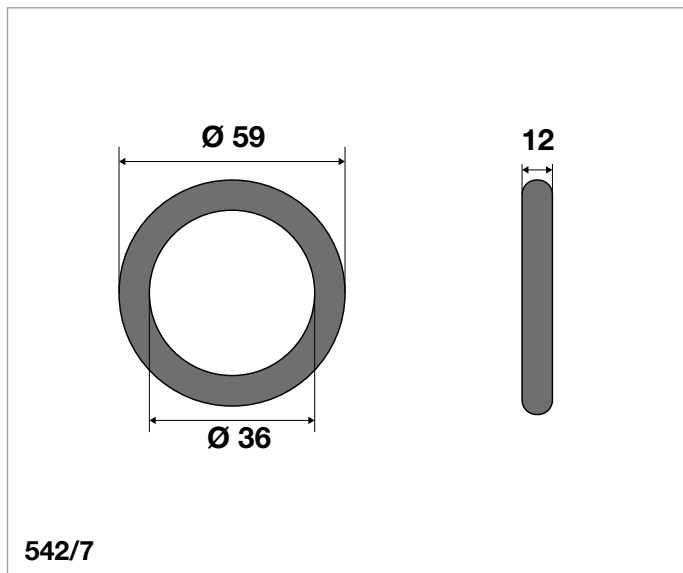
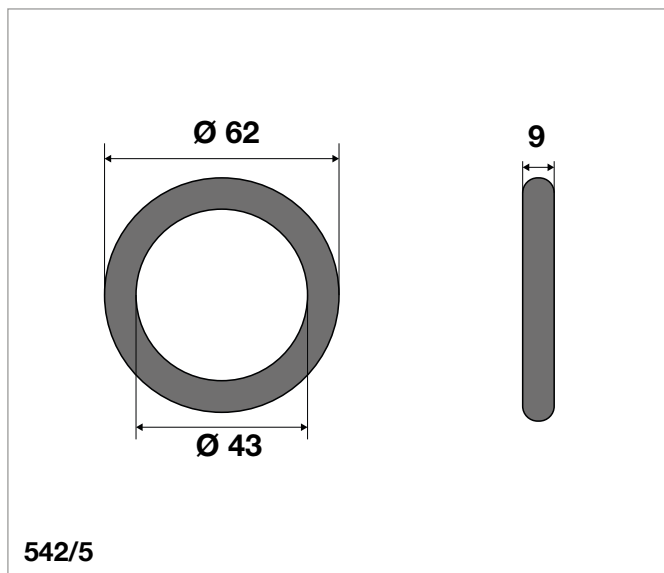
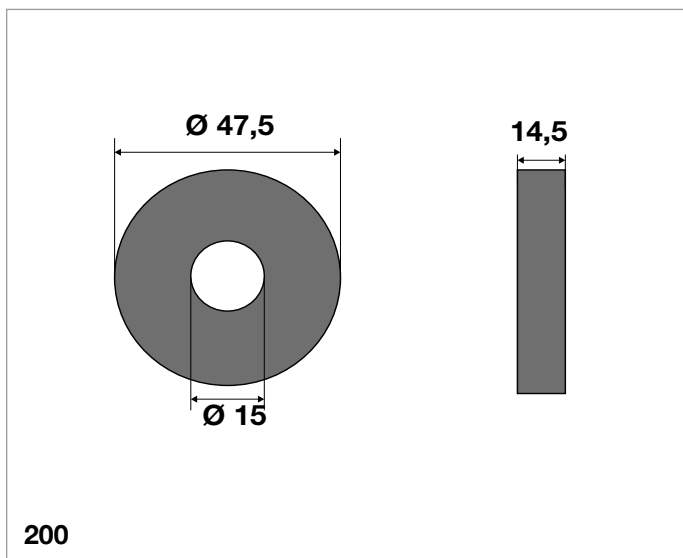
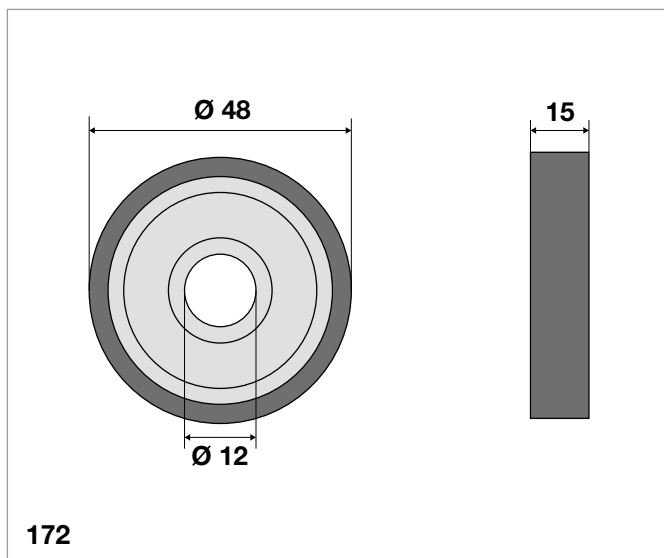
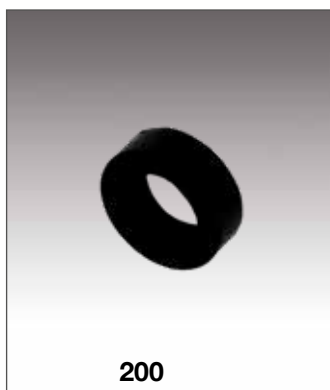

Codice / Code	Descrizione
172	Ruota limitatore di velocità SCHINDLER
200	Rotella in gomma per regolatore OTIS
542/5	Ruota in gomma per limitatore FALCONI nuovo
542/7	Ruota in gomma per limitatore FALCONI vecchio

NOTE

ALIMENTATORI - SIRENE - FOTOCELLULE
EMERGENCY POWER SUPPLY - ALARMS - PHOTOCELLS

Avvisatore acustico elettronico "GONG"	30.4
<i>Electronic alarm "GONG"</i>	
Alimentatori di emergenza con batteria	30.2
<i>Emergency power with battery</i>	
Campane badenia	30.3
<i>Alarms bells</i>	
Catarifrangenti tondi e rettangolari	30.6
<i>Circle and rectangular reflector</i>	
Fotocellula a 2 raggi	30.8
<i>Photocell a 2 beam</i>	
Fotocellula ascensore FIAM	30.7
<i>Photocell for lift FIAM</i>	
Fotocellula ATEX	30.12
<i>ATEX photocell</i>	
Fotocellula bicanale	30.11
<i>Two channel photocell</i>	
Fotocellule cilindriche "MINI EXTRA COMPATTE"	30.9
<i>Only cylinder photocells "EXTRA MINI COMPACT"</i>	
Fotocellula monocanale	30.10
<i>One channel photocell</i>	
Fotocellule standard	30.5
<i>Photocells standard</i>	
Sirene elettroniche	30.3
<i>Electronic alarm</i>	
Staffe per Fotocellule	30.5
<i>Bracket for photocell</i>	

Note: I componenti sul catalogo con riportata una specifica marca di ascensore sono utilizzati abitualmente solo da questa marca. I particolari senza marca sono utilizzati da più marche di ascensori.

Note: The components in the catalogue with a specific lift brand are usually used only by the brand. Unbranded parts are used by multiple lift brands.

ALIMENTATORI EMERGENCY POWER SUPPLY

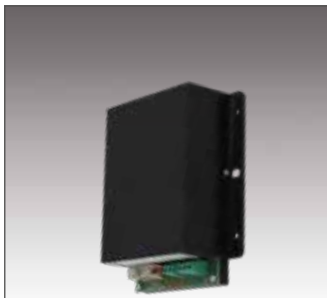

Alimentatore al piombo



Alimentatore al nichel cadmio

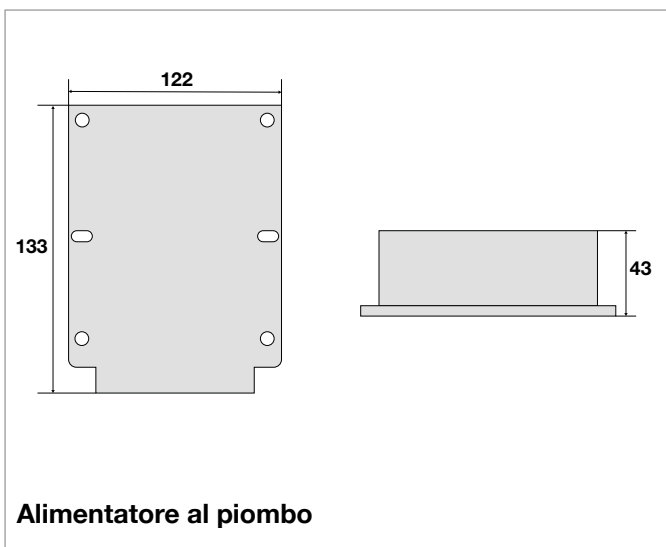

Alimentatore al piombo

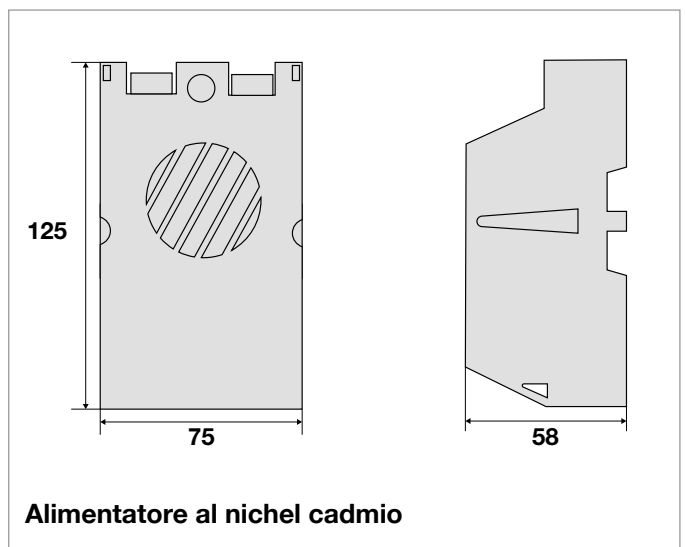

Alimentatore al nichel cadmio

N.B. Alimentatore al piombo

Codice / Code	Descrizione
300	Alimentazione 110/220Vac uscita 6Vcc 0,5 Ah
301	Alimentazione 110/220Vac uscita 6Vcc 1,2 Ah
302	Alimentazione 110/220Vac uscita 6Vcc 2,5 Ah
303	Alimentazione 110/220Vac uscita 12Vcc 0,5 Ah
304	Alimentazione 110/220Vac uscita 12Vcc 1,2 Ah
305	Alimentazione 110/220Vac uscita 12Vcc 2,8 Ah

N.B. Alimentatore al nichel cadmio

Codice / Code	Descrizione
300/1	Alimentazione 110/220Vac uscita 6Vcc 0,5 Ah
301/1	Alimentazione 110/220Vac uscita 6Vcc 1,2 Ah
301/1L	Alimentazione 110/220Vac uscita 6Vcc 1,2 Ah con uscita luce emergenza
303/1	Alimentazione 110/220Vac uscita 12Vcc 0,5 Ah
304/1	Alimentazione 110/220Vac uscita 12Vcc 1,2 Ah
304/1L	Alimentazione 110/220Vac uscita 12Vcc 1,2 Ah con uscita luce emergenza

SIRENE - CAMPANA A BADENIA ALARMS - ALARMS BELLS



351



353-354/1

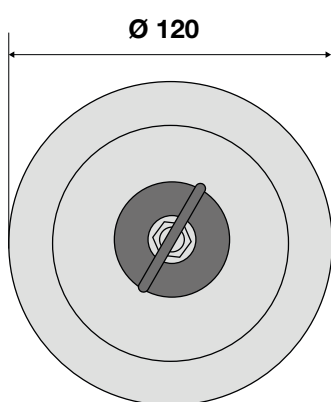

Ø 120

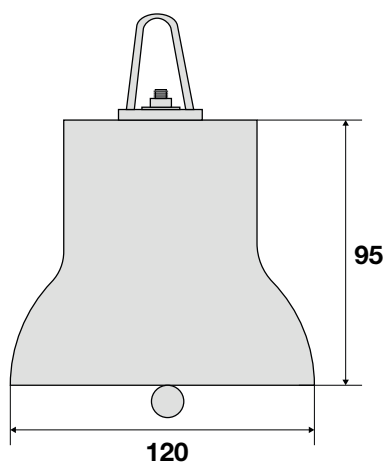

95

120

Campana badenia

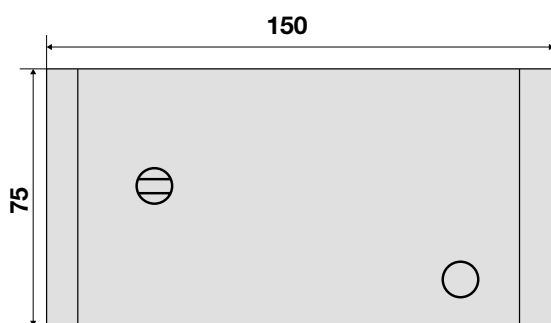

150

75

h. 30 mm

351

Codice / Code	Descrizione
351	Sirena elettronica. Alimentazione da 6 a 12Vcc, livello sonoro 104 db/1m Interasse di fissaggio: 112
353	Campana bandenia Ø 120 mm 4/6Vcc
354	Campana bandenia Ø 120 mm 12Vcc
354/1	Campana bandenia Ø 120 mm 2/4Vcc

AVVISATORE ACUSTICO ELETTRONICO ELECTRONIC ALARM



356

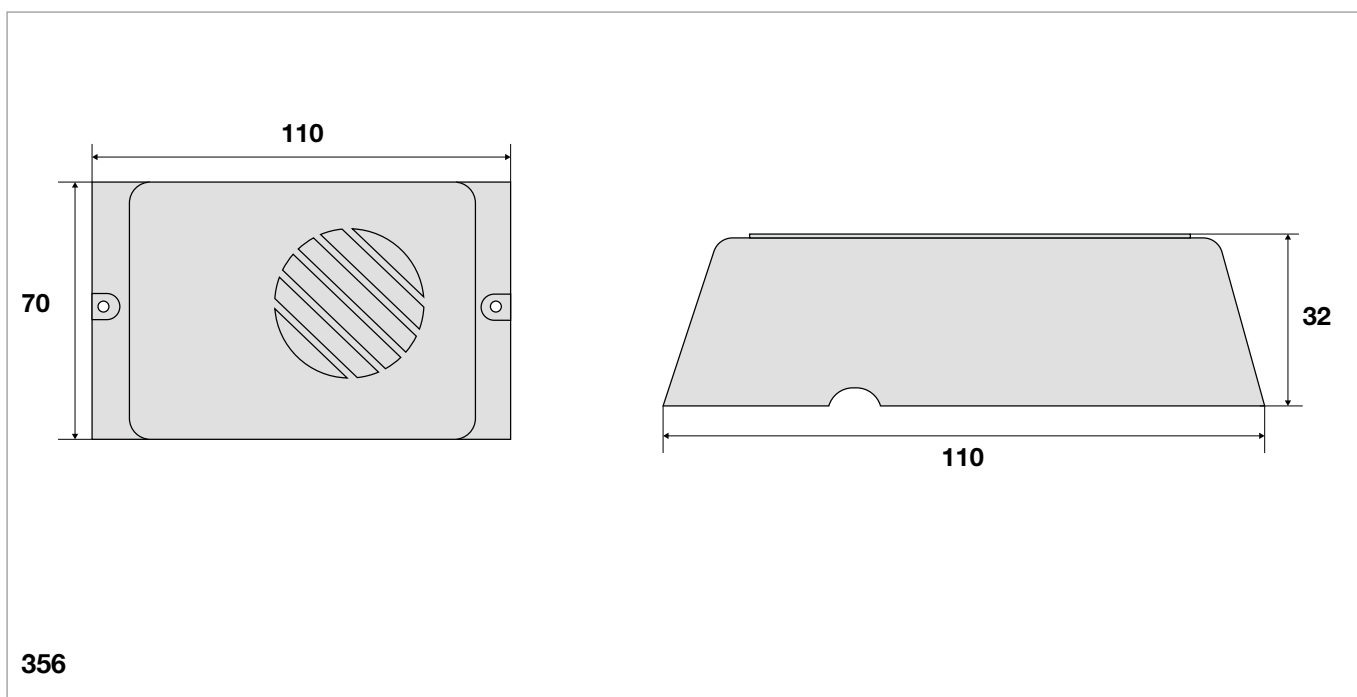

356

Possibilità di scegliere da 1 a 3 toni spostando semplicemente un ponte sul circuito.
Apparecchio dotato di regolazione tono e volume.

It's possible to choose between 1 to 3 tones, simply change a bridge on circuit set that equipped for tone and volume control.

30

Codice / Code	Descrizione
356	Avvisatore acustico elettronico per apertura porte "GONG"

Alimentazione / Power supply	Da 6 a 24V.cc
Consumo / Consumption	0,8A
Dimensioni / Dimensions	110 x 70 x 32 mm

FOTOCELLE STANDARD E STAFFE DI MONTAGGIO STANDARD PHOTOCELLS AND MOUNTING BRACKETS



359 - 359/1 - 359/2



362



363

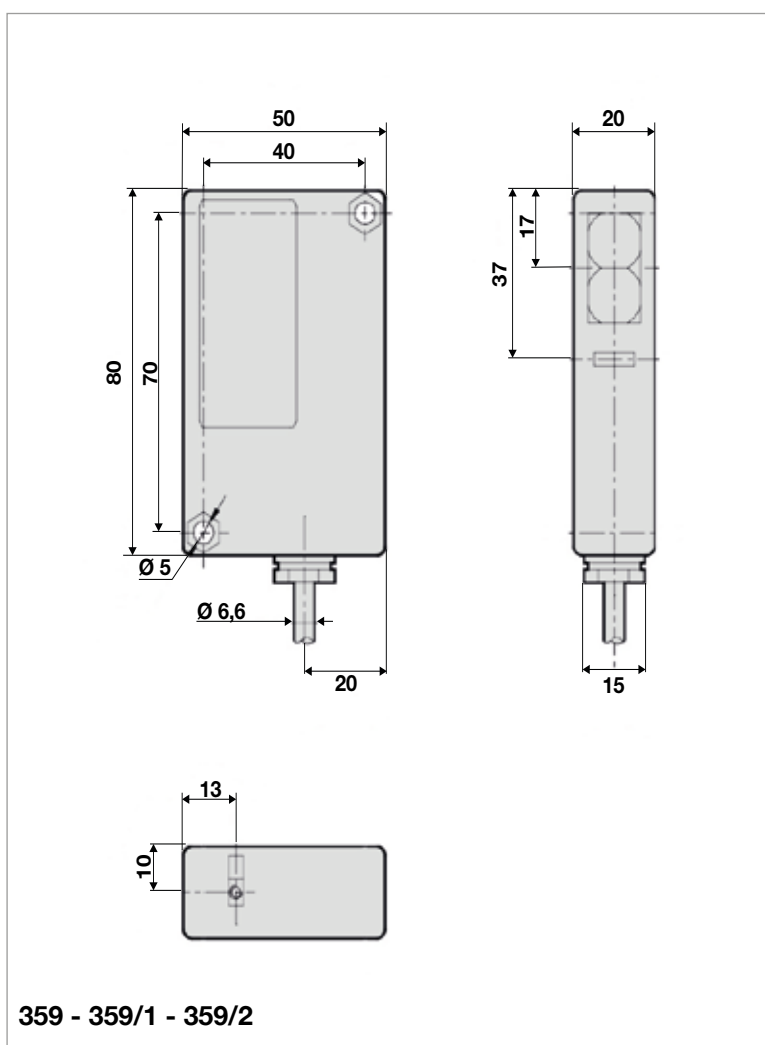

359 - 359/1 - 359/2

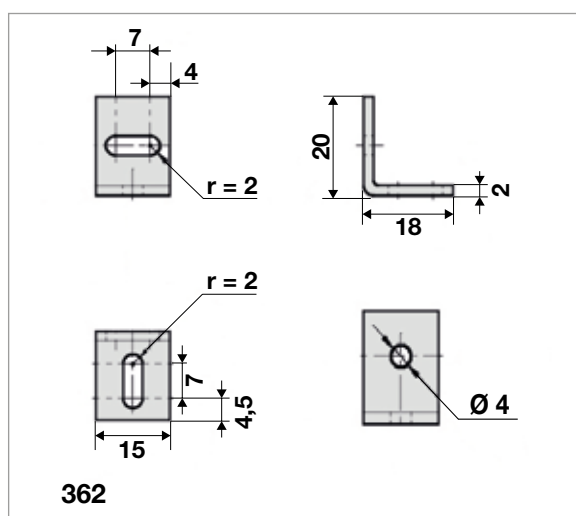

362

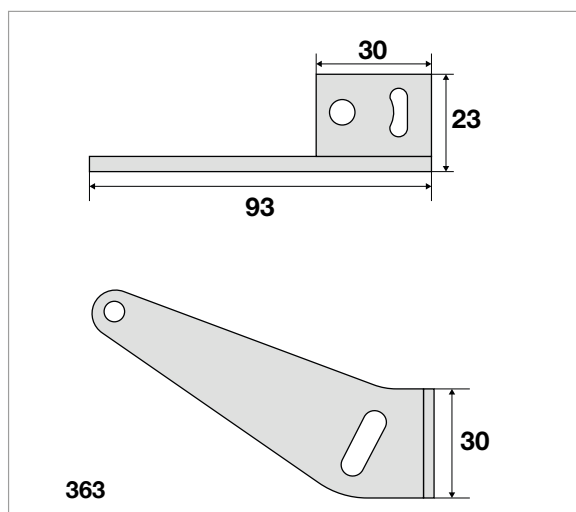

363

Codice / Code	Descrizione
359	Fotocellula a cavo 1535 12V portata 2,5 m
359/1	Fotocellula 24V portata 2 m
359/2	Fotocellula a cavo MR220F 220V portata 2 m
362	Staffa di montaggio piccola per codice 359-359/1-359/2
363	Staffa di montaggio grande 359-359/1-359/2

CATARIFRANGENTI REFLECTORS

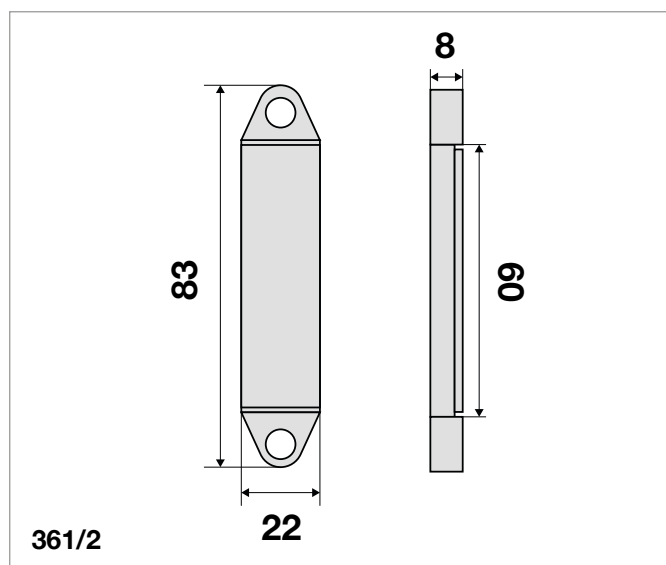
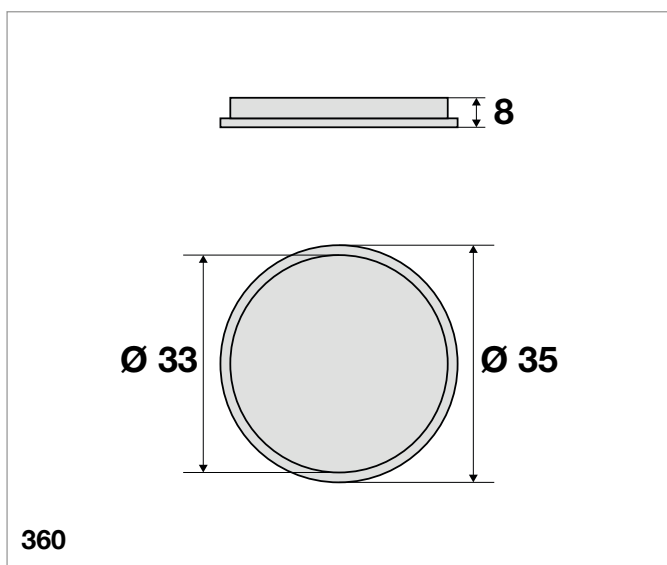

Codice / Code	Descrizione
360	Catarifrangente tondo D.30 mm
361/2	Catarifrangente rettangolare 22x60 a vite

FOTOCELLULA FIAM FIAM PHOTOCELL



355

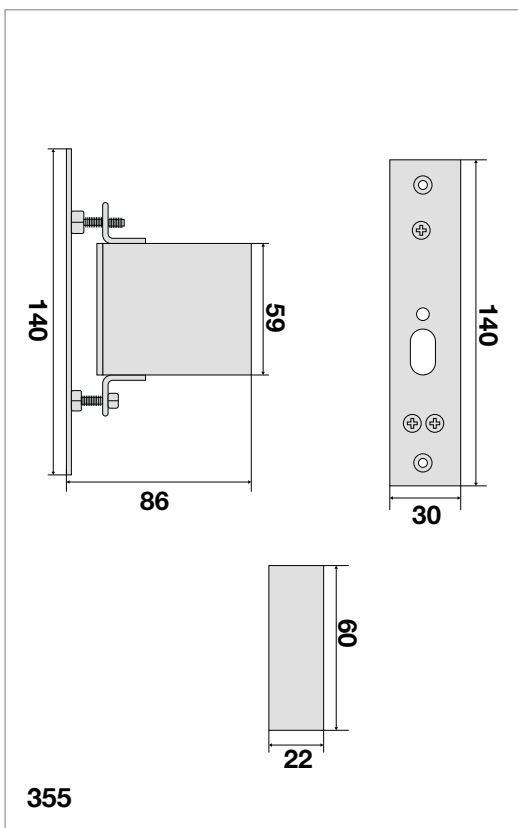

355

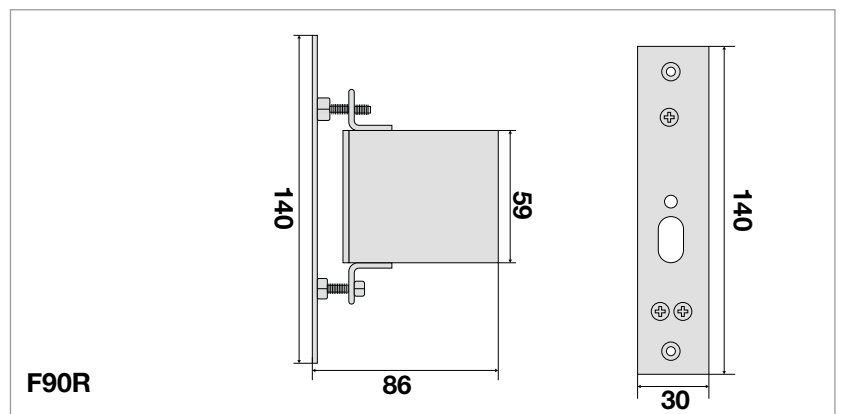

F90R

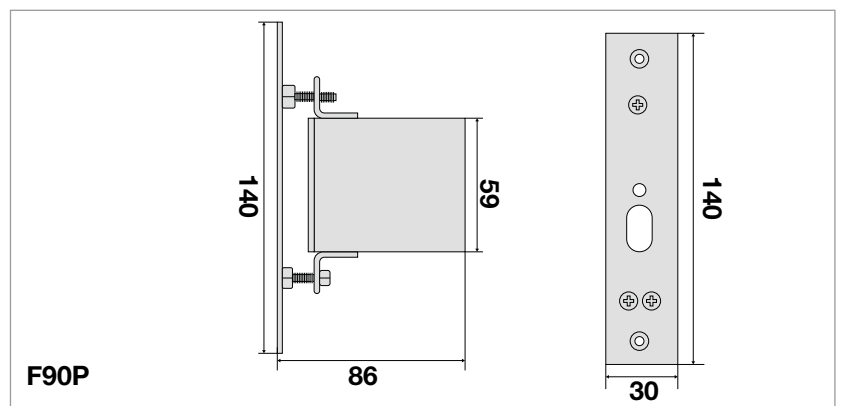

F90P

Codice / Code	Descrizione
355	Fotocellula tipo F/90 reflex FIAM ovvero con catarifrangente (specchio riflettente)

Caratteristiche tecniche

Alimentazione	24Vac/cc +/-15%
Uscita	1 relè di scambio 2A - 220 Vca non induttivo
Campo di lavoro	Max 2mt
Grado di protezione	IP 65
Assorbimento	Max 3 W

Codice / Code	Descrizione
F90P	Proiettore delle fotocellula tipo F/90 reflex cod. 355
F90R	Ricevitore delle fotocellula tipo F/90 reflex cod. 355

FOTOCELLULA A 2 RAGGI PHOTOCELL WITH 2 BEAMS



- Sistema multiplexato e sincronizzato per un'alta immunità ai disturbi
- Gestione di 2 raggi, 1 uscita relè
- Elettronica ridondante
- Semplicità di installazione
- Regolazione sensibilità

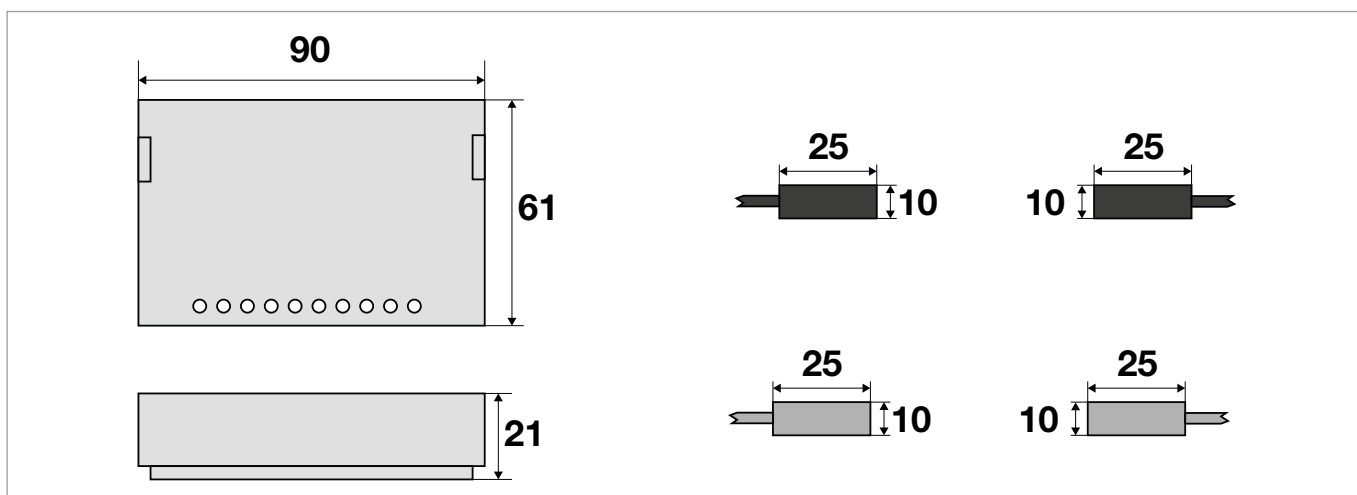

Codice / Code	Descrizione
357	Fotocellula a 2 raggi multipli (centralina + 2 ricevitori + 2 proiettori Ø 12 x 25 mm)

Caratteristiche tecniche

Alimentazione	12÷24 Vac/dc
Consumo	1.5 W
Assorbimento	60 mA
Contenitore	ABS
N° uscite relè	1 - N.O. / N.C.
Tempo d'intervento	50ms
Tempo di ripristino	0,25 s
Lunghezza d'onda infrarosso	950 nm
Compatibilità sonde	CR10, CR20, CR9, CRF
Grado di protezione	IP 42
Temperatura di funzionamento	da -20° a +55°C
Dimensioni e peso	135x75x65 mm - 400g

FOTOCELLULE CILINDRICHE “MINI EXTRA COMPATTE” CYLINDER PHOTOCELL “EXTRA MINI COMPACT”



CR10MS, è una mini sonda per porte automatiche e ascensori, con portata 10 m, realizzata con cavo schermato che può essere installata con fissaggio ad incasso, a parete e nella costa ottica di sicurezza tramite gli adattatori in dotazione.

- Portata nominale 10 m
- Sonde resinate, IP 67
- 3 sistemi di fissaggio

CR10MSC come **CR10MS** ma con connettore stagno per consentire la veloce sostituzione della sonda ottica.

- Connettore stagno a 20 cm della sonda

Codice / Code	Descrizione
357/1	Fotocellule cilindriche + proiettore + ricevitore “mini extra compatte” per codice 357

Caratteristiche tecniche

	CR10MS (proiettore)	CR10MSC (ricevitore)
Portata fascio infrarosso	10 m nominali	10 m nominali
Lunghezza cavo Tx + Rx	8 m + 8 m	8 m + 8 m
Compatibilità amplificatore	Serie FOTO 9	Serie FOTO 9
Grado di protezione	IP 67	IP 67
Temperatura di funzionamento	Da -20° a +55°C	Da -20° a +55°C
Dimensioni	ø 13, prof.18mm	ø 13, prof.18mm
Alimentazione	12÷24 Vac/dc	

FOTOCELLULA MONOCANALE MONOCANAL PHOTOCELL

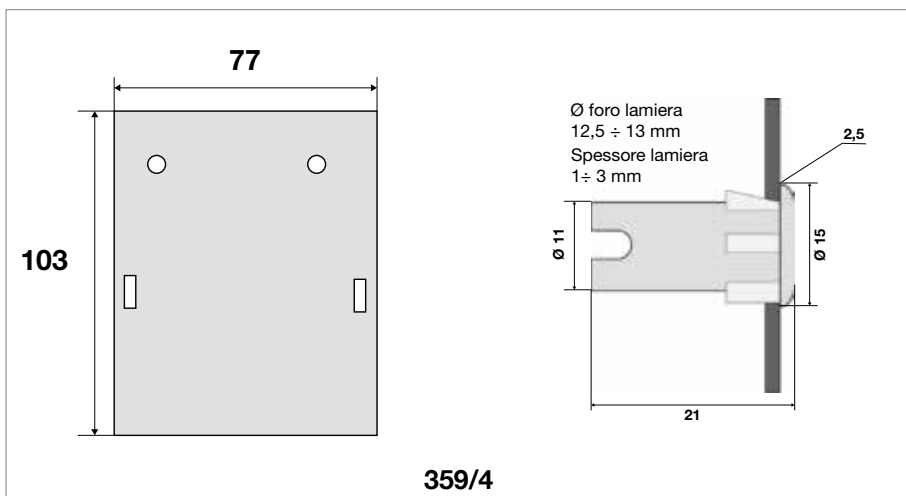

Questa è una fotocellula in grado di gestire una coppia di sensori.
Il circuito è protetto da inversione di polarità e da extratensioni impulsive (allunga notevolmente la durata dei contatti del relè)

Monta un relè a doppio contatto di 3Ah.

L'immunità da disturbi elettrici e ottici è ottima.

L'installazione è semplicissima e non richiede interventi sul circuito.

This photocell work with 2 sensors. The circuit is protected by inversion of polarity and by impulsive of extra voltage (considerably lengthen the lifetime of relay contact) and mount a relay with double contact of 3Ah. Immunity is excellent for electrical and optical disorders.

The installation is very simple and doesn't require any intervention on the circuit.

Codice / Code	Descrizione
359/4	Fotocellula monocanale precablata con certificato di conformità

Caratteristiche tecniche

Portata / Range	0,1 ÷ 10 mt.
Protezione / Protection degree	IP 30
Alimentazione / Power supply	12 ÷ 24 V.cc - V.ca
Assorbimento / Power consumption	50 mA
Temperatura di funzionamento / Operating temperature	-15° ÷ +50°
Uscita / Output	Relè contatto N.O/N.C
Portata contatti / Output contacts (protetti da extratensioni/protected by extra tensions)	3A - 48 V. doppio contatto dorati
Raggio / Optical ray	Infrarosso 900 nm
Tempo di risposta / Response time	15ns.
Conformità / Approval	89/336/CEE

FOTOCELLULA BICANALE DUAL-CHANNEL PHOTOCELL

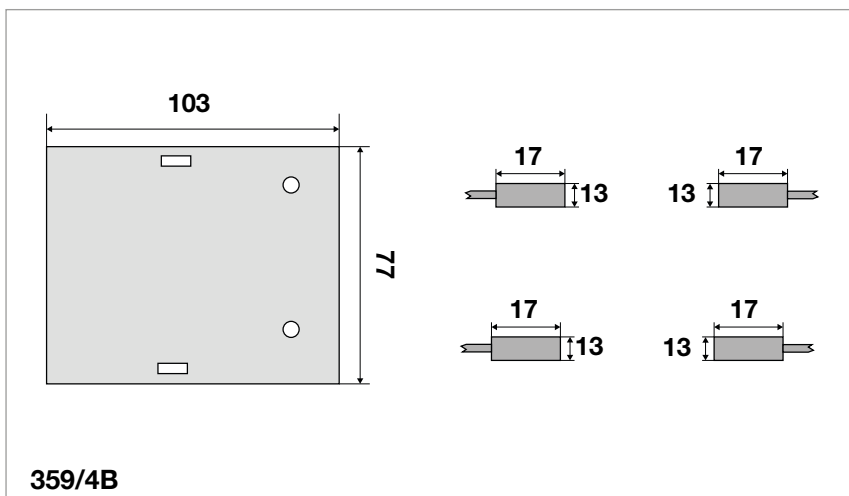

Questa è una fotocellula in grado di gestire due coppie di sensori.
Il circuito è protetto da inversione di polarità e da extratensioni impulsive (allunga notevolmente la durata dei contatti del relè).

Monta un relè a doppio contatto di 3Ah.

L'immunità da disturbi elettrici e ottici è ottima.

L'installazione è semplicissima e non richiede interventi sul circuito.

This photocell work with 4 sensors. The circuit is protected by inversion of polarity and by impulsive of extra voltage (considerably lengthen the lifetime of relay contact) and mount a relay with double contact of 3Ah. Immunity is excellent for electrical and optical disorders.

The installation is very simple and doesn't require any intervention on the circuit.

Codice / Code	Descrizione
359/4B	Fotocellula bicanale precablata con certificato di conformità

Caratteristiche tecniche

Portata / Range	0,1 ÷ 10 mt.
Protezione / Protection degree	IP 30
Alimentazione / Power supply	12 ÷ 24 V.cc - V.ca
Assorbimento / Power consumption	50 mA
Temperatura di funzionamento / Operating temperature	-15° ÷ +50°
Uscita / Output	Relè contatto N.O/N.C
Portata contatti / Output contacts (protetti da extratensioni/protected by extra tensions)	3A - 48 V. doppio contatto dorati
Raggio / Optical ray	Infrarosso 900 nm
Tempo di risposta / Response time	15ns.
Conformità / Approvals	89/336/CEE

FOTOCELLULA ATEX ATEX PHOTOCELL



750/EX

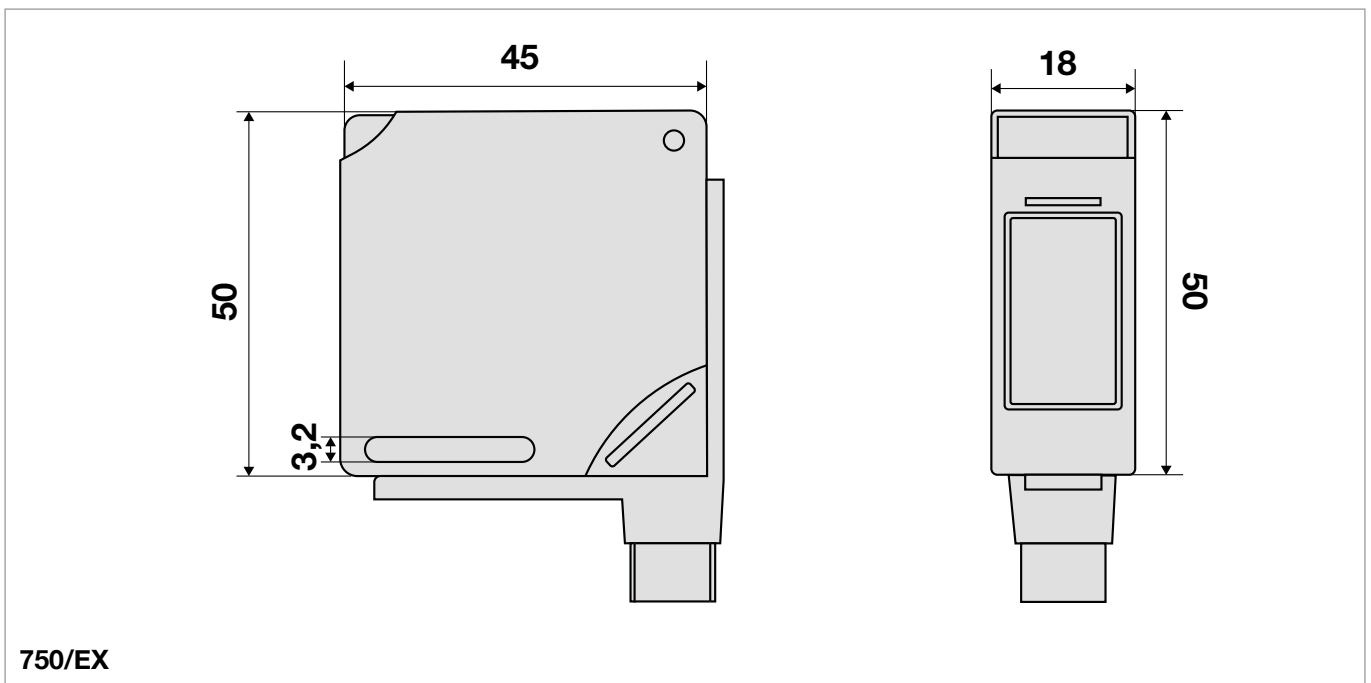

750/EX

Codice / Code	Descrizione
750/EX	Fotocellula ATEX

SCIVOLI PER PORTE AUTOMATICHE
DOOR COUPLING SLIDE FOR AUTOMATIC DOOR

FIAM corto 325x35	31.2
<i>Short FIAM 325x35</i>	
FIAM lungo 700x50	31.2
<i>Long FIAM 700x500</i>	
Standard	31.2

Note: I componenti sul catalogo con riportata una specifica marca di ascensore sono utilizzati abitualmente solo da questa marca. I particolari senza marca sono utilizzati da più marche di ascensori.

Note: *The components in the catalogue with a specific lift brand are usually used only by the brand. Unbranded parts are used by multiple lift brands.*

SCIVOLI PER PORTE AUTOMATICHE DOOR COUPLING SLIDE FOR AUTOMATIC DOOR

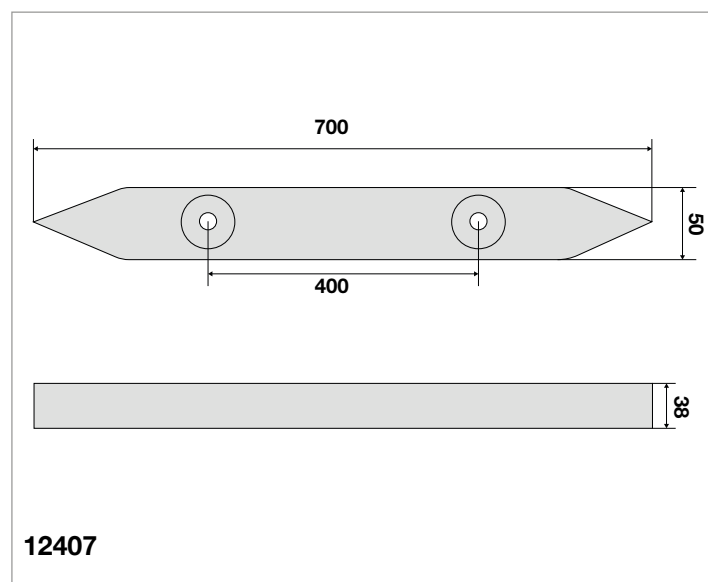
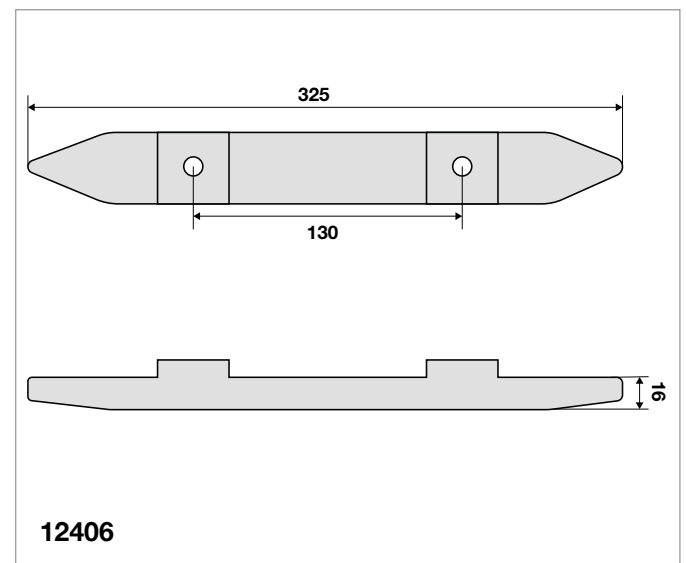
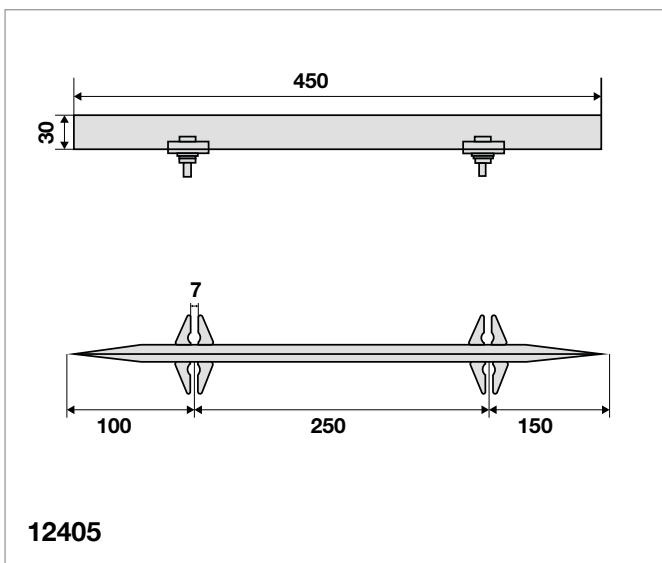

Codice / Code	Descrizione
12405	Scivolo standard per accoppiamento porte automatiche
12406	Scivolo standard per accoppiamento porte FIAM
12407	Scivolo lungo per accoppiamento porte FIAM

TELESOCORSO PER CABINE
EMERGENCY TELEPHONE FOR CABIN

Telesoccorso per cabina MEMCO 32.2
Emergency telephone MEMCO

Depuratore d'aria per cabina ascensore anti COVID e batteri Ds Air Extra Compact..... 32.3
Air cleaner for cabin lift anti COVID and bacteria Ds Air Extra Compact

Note: I componenti sul catalogo con riportata una specifica marca di ascensore sono utilizzati abitualmente solo da questa marca. I particolari senza marca sono utilizzati da più marche di ascensori.

Note: *The components in the catalogue with a specific lift brand are usually used only by the brand. Unbranded parts are used by multiple lift brands.*

TELESOCOCCORSO PER CABINA EMERGENCY KEYS



370



371



372



373

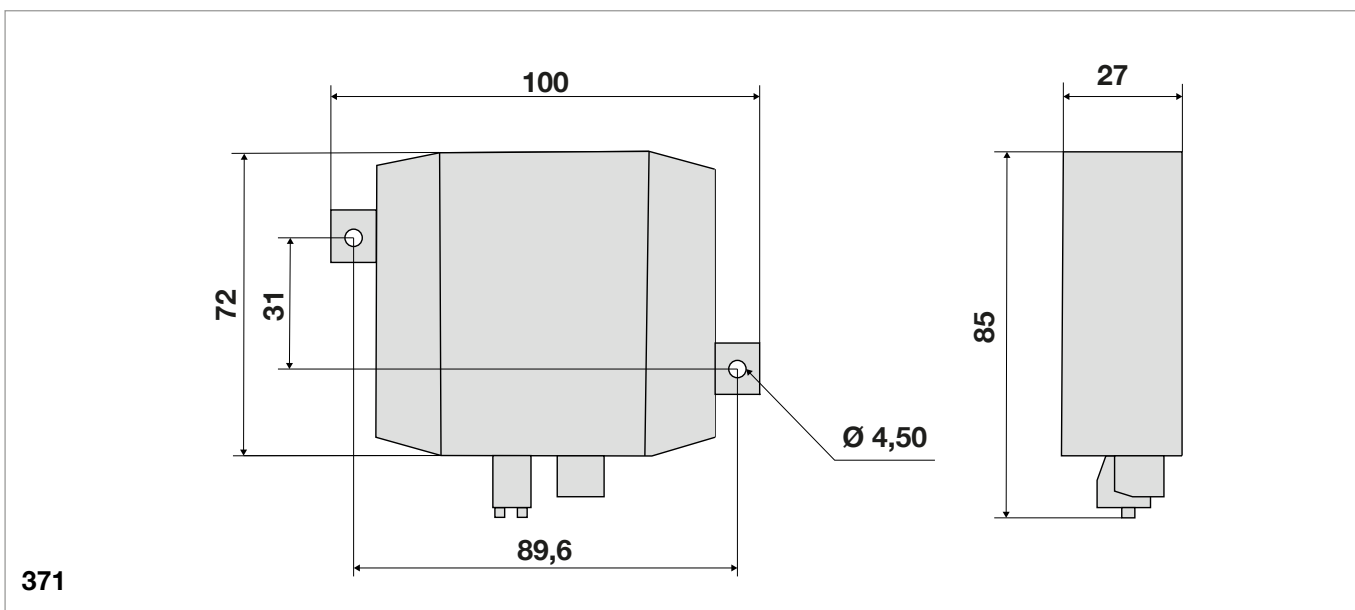

371

Codice / Code	Descrizione
370	Telesoccorso per cabina MEMCO C100 FM3 Applicazione sovrapposta Installazione plug and play Pittogramma retroilluminato Chiamo auto-test secondo EN81-28

Caratteristiche principali:

Programmazione semplificata (one touch)

'Plug and play' installazione

Unità di programmazione rimovibile

Piastra frontale personalizzabile

Illuminazione di emergenza integrata

Pittogrammi retroilluminati

Circuito induttivo integrato disponibili (450 290)

Software MEMCO ETR - per una facile gestione delle emergenze, tecniche e chiamate auto-test EN81-28.

Conforme alle norme EN 81-28 e EN 81-70

Codice / Code	Descrizione
371	Batteria emergenza C100 PSU 12Vcc per MEMCO C100
372	Posto esterno C100 LVAS per MEMCO C100 Plug and play con connettore RJ
373	Programmatore per MEMCO C100

DEPURATORE D'ARIA PER CABINA ASCENSORE ANTI COVID E BATTERI DS AIR EXTRA COMPACT AIR CLEANER ANTI COVID AND BACTERIA FOR CABIN LIFT DS AIR EXTRA COMPACT



Il depuratore d'aria per cabine di ascensori è dotato di filtro HEPA H12/H13 e di filtro lavabile.

Protegge da batteri Virus-SARS COV2 - batteri - PM 10 - PM 2,5 - VOC avendo filtri certificati secondo EN1822.

Test più severo per filtri HEPA utilizzati all'interno di ospedali e camere bianche.

Ha un basso consumo elettrico (7 Watt MAX) con dimensioni extracompatte Ø 220 mm. x h. 160 mm.

Si può installare con mensola (non di nostra fornitura) all'interno della cabina, nello spigolo superiore sotto il soffitto di cabina, oppure incassato a soffitto con piastra di montaggio.

Con questo dispositivo si supera il problema di durata della disinfestazione con OZONO, garantendo una disinfestazione continua garantita per 3 anni (esclusi filtri).

Dati Tecnici

Alimentazione	230 Vac e 24 Volt
Inserzioni orarie	100% ins.orarie (sempre acceso)
Peso	1,8 Kg.
Dimensioni	Diametro 220 mm. x h. 160 mm
Consumo	7 Watt. ora MAX
Portata	1,27 m3/h

Manutenzione periodica

Prefiltri lavabili	12 - 24 mesi
Cartuccia di carbone attivo	9 - 12 mesi
Filtro HEPA	2 - 4 anni

Si consiglia la sostituzione di tutti i filtri una volta all'anno

Codice / Code	Descrizione
K1	Ds air compact extra compatto per cabine ascensore completo di doppio prefiltro + cartuccia in carboni attivi + filtro HEPA
K2	Piastra di montaggio ad incasso
K3	Filtro HEPA certificato
K4	Doppio prefiltro
K5	Cartuccia filtro a carbone attivo

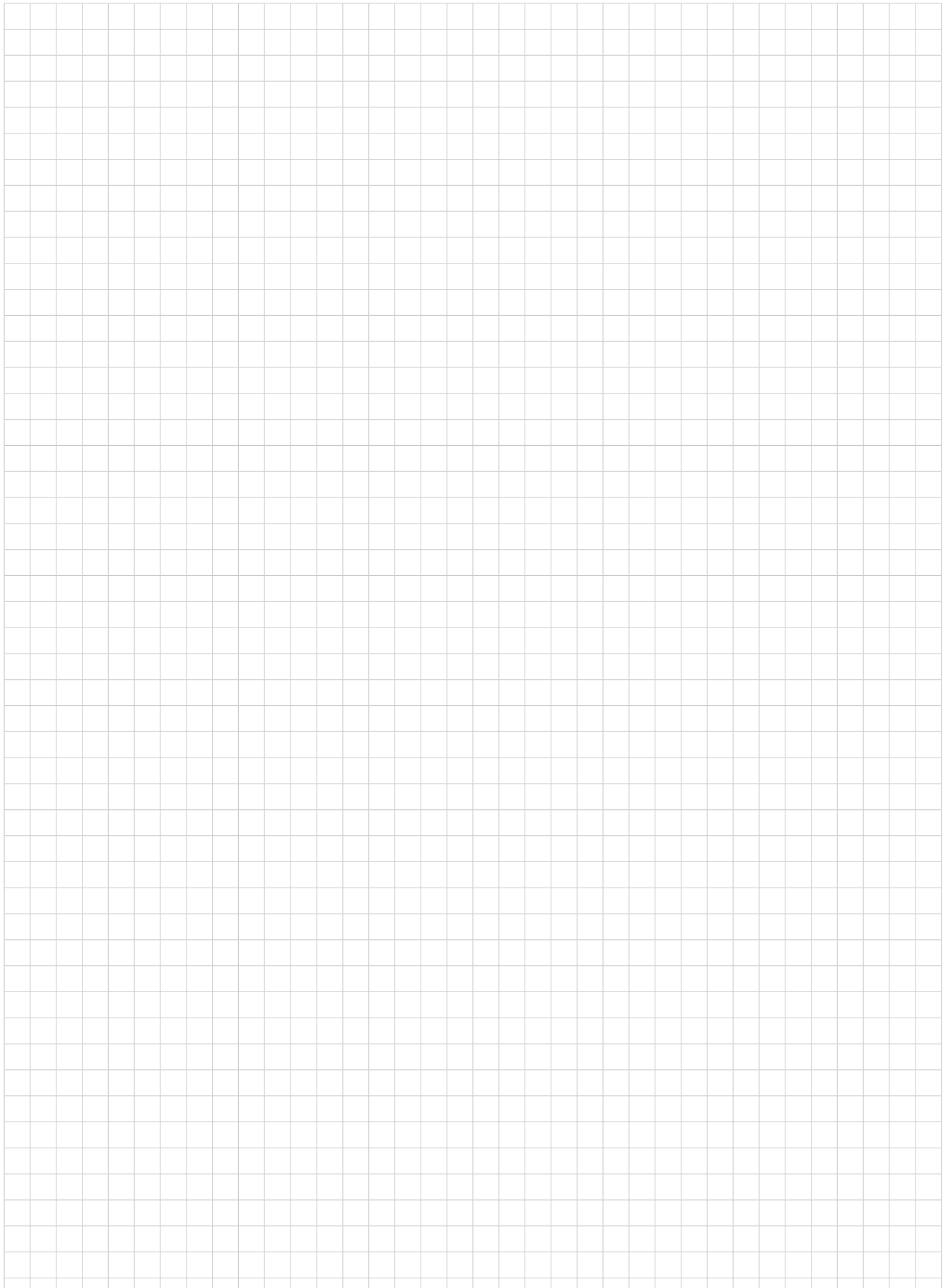

NOTE



CHI SIAMO

DS Dictator nasce nel 1982 come importatore di prodotti per ascensori Dictator, quindi affiancando a tutti i prodotti Dictator i chiudiporta Ryobi.

Oggi opera principalmente in 3 settori:

- Chiudiporta (107 modelli) per ascensori e porte in genere, ricambi ascensori
- Componenti per l'industria di porte antincendio frigo, forni, cabine silenziose, carpenterie speciali, impianti di controllo accessi, il tutto anche ATEX
- Protezione passiva e attiva antincendio di impianti e strutture.

I prodotti Dictator Ryobi e Ds Dictator sono prodotti di qualità con certificazioni secondo norme vigenti scaricabili dal nostro sito

CONTATTI

DS Dictator Srlu
Via P. e M. Curie, 5/7 20019 Settimo Milanese (MI)
Tel +39 02 47994578 +39 02 47995278
Fax +39 02 47995131
www.dsdictator.com

e-mail per informazioni tecnico commerciali:
info@dsdictator.it tecnico-commerciale@dsdictator.it

e-mail per invio ordini e informazioni su gestione ordini:
ordini@dsdictator.it

e-mail per contabilità:
contabilita@dsdictator.it